

LASER INTERFEROMETER GRAVITATIONAL WAVE OBSERVATORY  
- LIGO -  
CALIFORNIA INSTITUTE OF TECHNOLOGY  
MASSACHUSETTS INSTITUTE OF TECHNOLOGY

Technical Note	LIGO-T1900384-v1	2019/05/14
<b>Explorations in Cryogenic High-Q Mechanical Resonators</b>		
Shubhabroto Mukherjee Mentors : Rana X. Adhikari, Aaron Markowitz, Duo Tao		

**California Institute of Technology**  
**LIGO Project, MS 18-34**  
**Pasadena, CA 91125**  
Phone (626) 395-2129  
Fax (626) 304-9834  
E-mail: info@ligo.caltech.edu

**Massachusetts Institute of Technology**  
**LIGO Project, Room NW22-295**  
**Cambridge, MA 02139**  
Phone (617) 253-4824  
Fax (617) 253-7014  
E-mail: info@ligo.mit.edu

**LIGO Hanford Observatory**  
**Route 10, Mile Marker 2**  
**Richland, WA 99352**  
Phone (509) 372-8106  
Fax (509) 372-8137  
E-mail: info@ligo.caltech.edu

**LIGO Livingston Observatory**  
**19100 LIGO Lane**  
**Livingston, LA 70754**  
Phone (225) 686-3100  
Fax (225) 686-7189  
E-mail: info@ligo.caltech.edu

# 1 Introduction

Gravitational waves are ripples in fabric of space-time caused by some of the most violent and energetic processes in the Universe. Propagating at the speed of light, it tends to create a differential strain in the orthogonal directions. On September 14, 2015, hours after Laser Interferometer Gravitational-Wave Observatory(LIGO) came back into operation, it physically sensed the distortions in space-time caused by passing gravitational waves generated by two colliding black holes nearly 1.3 billion light years away. Its detection confirms the last remaining prediction of Albert Einstein’s theory of general relativity. It also indicates that black holes exist, black holes can coalesce or merge, neutron stars coalesce and many more scientific predictions related with the merger of such stars.

## 1.1 LIGO Construction

LIGO uses an interferometric technique to detect this differential strain in the Michelson Interferometers. Each arm, 4 km long, contains a resonant optical cavity, formed by its two test mass mirrors, that multiplies the effect of gravitational wave on the light phase by a factor of 300[1]. Second, a partially transmissive power-recycling mirror at the input provides additional resonant buildup of the laser light from 20 W to 700 W, which is further increased to 100 kW circulating in each arm cavity[1]. Third, a partially transmissive signal-recycling mirror at the output broadens the bandwidth of the arm cavities and thus optimizes the gravitational-wave signal extraction[1]. The never ending quest for knowledge led to the explorations to achieve one of the best state of the art system ever built. The next generation of LIGO detectors, LIGO Voyager aims to see the never before with its 200 kg silicon test masses at 123 K, 3 MW of arm cavity power and  $\sim 25\%$  increased beam spot size[2].

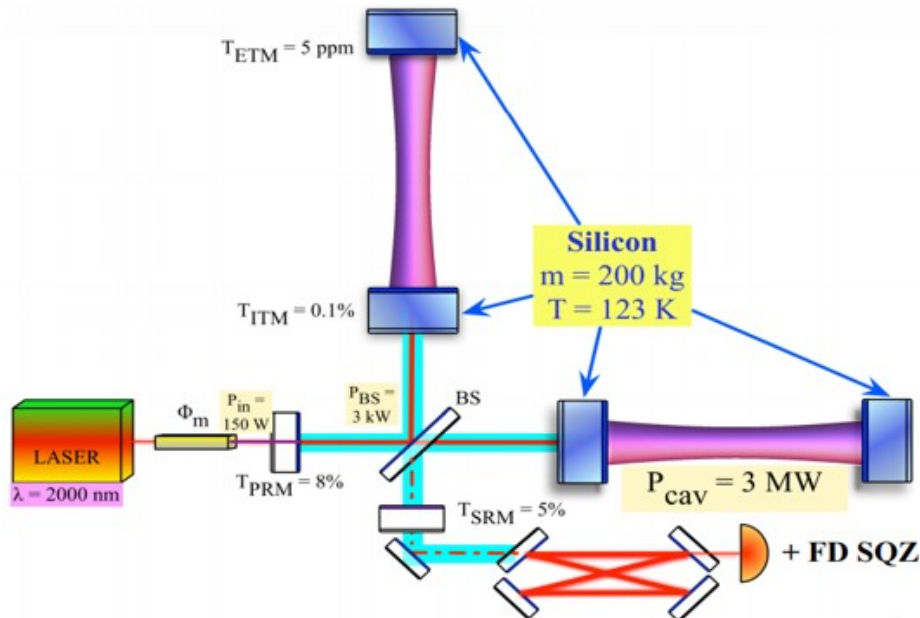

Figure 1: Proposed Schematic of LIGO Voyager [3]

## 1.2 Strain sensitivity

Though the strain caused by gravitational waves is very small, LIGO is currently sensitive enough to detect strain below  $10^{-23}/\sqrt{\text{Hz}}$  between 70 and 1000 Hz. Such a high sensitivity also means that it is also susceptible to extremely small sources of noise. Thermal noise generated by absorbance of laser in the mirror-coatings and change of material properties because of temperature rise is a major limitation which needs to be solved for future upgrades like Voyager. The noise budget of LIGO Voyager is presented in Fig. 2. Also regular Brownian noise, unrelated to any absorption or heating due to the laser, is a limiting problem; in particular, Voyager will be limited by coating Brownian noise and suspension Brownian noise. The thermal noise is a limiting source of displacement noise in a broad class of optomechanical measurement devices operating at or near their quantum limits.

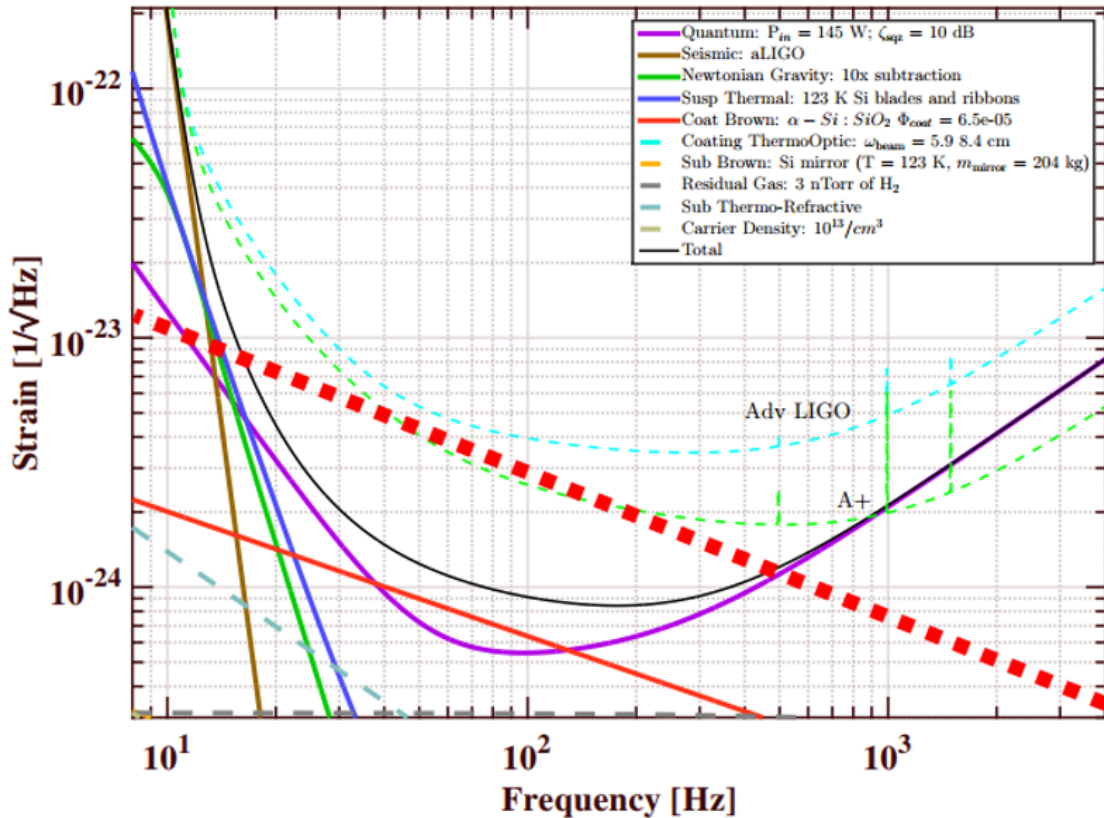

Figure 2: Proposed Noise Budget of LIGO Voyager [2]

## 1.3 New Detection

The LIGOs twin detectors, in Washington and Louisiana, have been offline, for several months, undergoing upgrades to their lasers, mirrors, and other components, which will enable the detectors to listen for gravitational waves over a far greater range, out to about 550 million light-years away - around 190 million light-years farther out than before[6]. They

are again into operation since April 2019 and having their O3 run being presently being on-going. The first new detection came on April 8 2019, a week after a trio of super-sensitive gravitational-wave instruments began new observations[7]. The new observing run also marks the first time that three different detector facilities - two LIGO outposts in Washington state and Louisiana, plus the Virgo detector in Italy - have been observing together for a sustained period[7].

## 2 Cryo-Q

To take advantage of low thermal noise properties of silicon at cryogenic temperatures, a low-loss optical coating must be developed and characterized. The properties of bare silicon are fairly well known, hence the Cryo-Q device is effective in testing the candidate coated silicon disks, such as amorphous silicon, by comparing their properties with bare silicon.

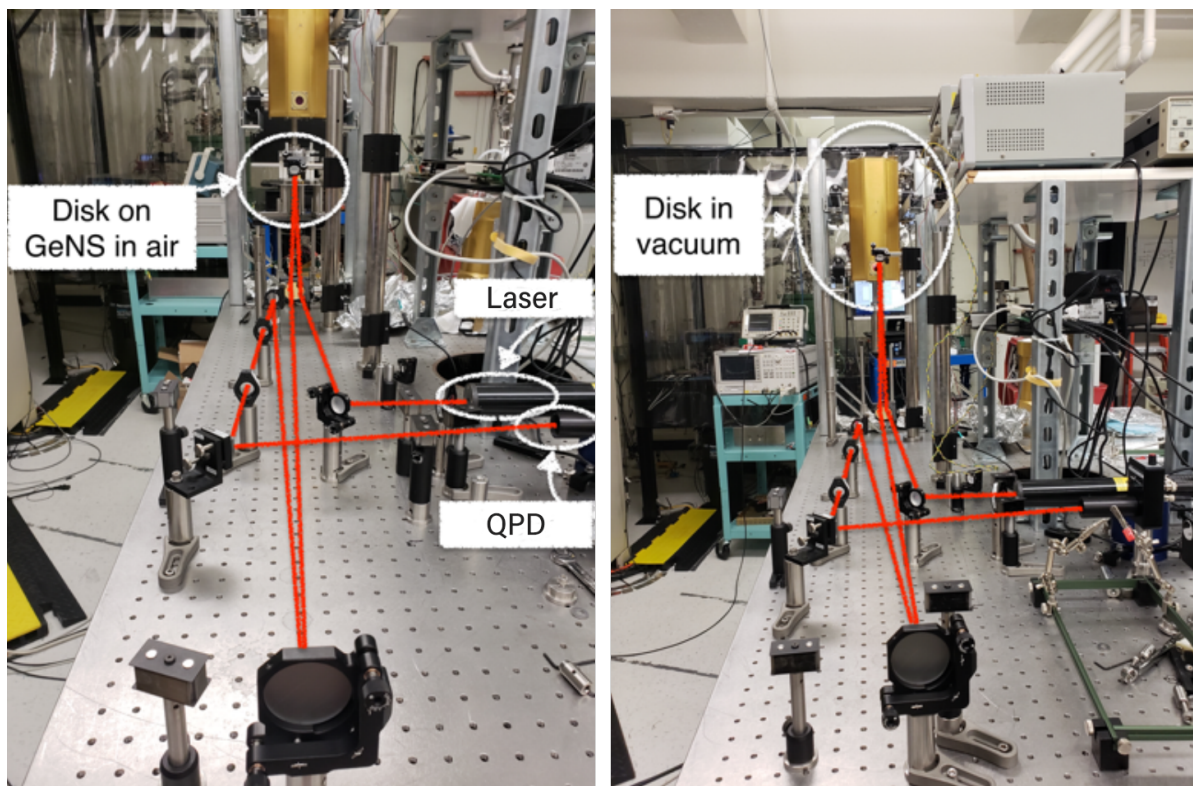

Figure 3: Laser path is highlighted by red colour. Left: GeNS suspends the disk on a platform outside of the cryostat. Incident Laser travels through a beam splitter and periscope. Once the laser is reflected off the disk, it makes its way back to the periscope, then off an optical system before reaching the QPD. Right: The disk inside a cryostat to be contained in vacuum. GeNS suspends the disk within the cryostat. [4]

A thin silicon disc (with or without desired coating material) is kept in a balanced condition with single point contact at liquid nitrogen temperatures under sub-atmospheric pressure, and excited using an electrostatic actuator. A laser beam is incident on the disk, and the

reflected beam is guided to a quadrant photodiode (QPD). The ringdown pattern is studied which bears the signature of material's properties under different experimental conditions giving an estimate of the quality factor,  $Q$  (eq.1).

$$Q = 2\pi \left( \frac{\text{Total energy of the system}}{\text{Energy loss per cycle of operation}} \right) = \frac{\omega_o \tau}{2} = \pi f_0 \tau \quad (1)$$

### 3 Objectives

My overall project covers various aspects of the recently developed testbed for measuring the internal friction of thin disk resonators to explore open problems in controlling and optimizing such systems, such as:

- Testing candidate materials for low-loss coatings for LIGO optics.
- Optimal experimental design for measuring resonators with nonconventional topologies.
- New method for fast, non-contact precise temperature readout and control.
- Establish the temperature and frequency dependence of the disk as a function of chopping amplitude and frequency.
- Create a more detailed noise budget which accounts for secondary measurement uncertainties as well.

### 4 Experimental approach

The set-up of this project involves a cryostat enclosing the following environment: the sample, a silicon disk coated with candidate material which rests on a hemispherical silicon structure to minimize friction; an electrostatic drive(ESD) to excite the silicon disk; a laser beam along with guiding optics to impinge on the disk and reflected light being directed to the quadrant photodiode. Additionally, there will be a green laser with mechanical chopper or an electronic modulator of laser power, and RTDs to provide temperature readouts of the environment inside the cryostat. The temperature of the disk is stabilized by measuring frequency shifts in the disk eigenmodes. The absolute temperature calibration is provided by the zero crossing of the coefficient of thermal expansion.

Initially, the disc will be excited using the ESD and QPD output will be measured. Necessary steps will be taken for noise reduction. Subsequent to that, a laser chopper or electronic laser power modulator will be operated in the green laser path and the effect of signal output from QPD, when driving the chopper to the modes of the excited silicon disc, will be fed in as input signal to the Lock-in Amplifier. A lock in amplifier will take reference input from the chopper driver and provide amplitude and phase readout to data acquisition system.



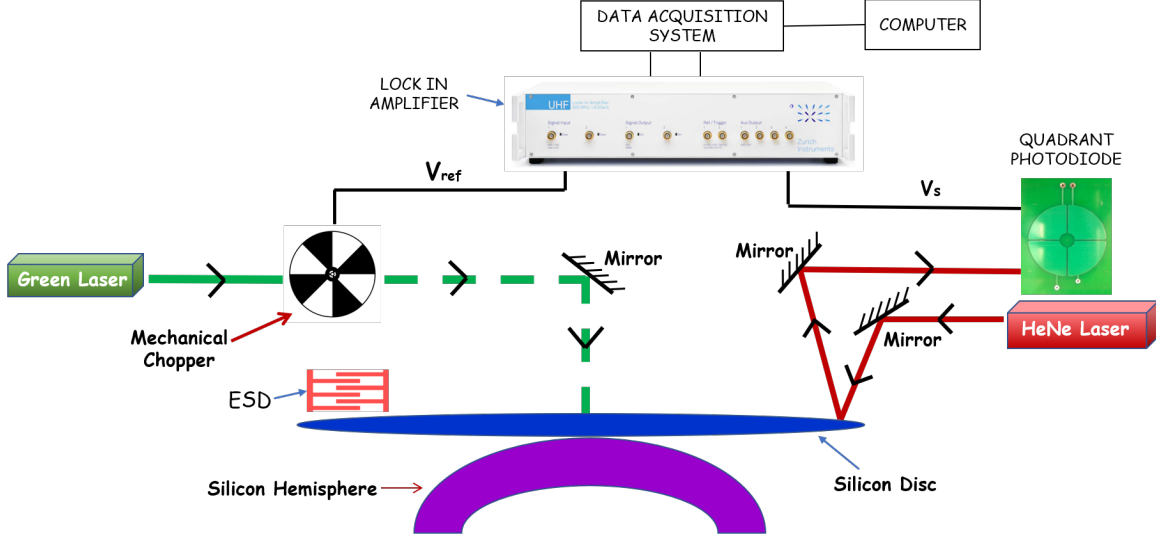

Figure 4: Schematic Experimental Setup

Slow chopping frequency, chopping near the mode frequency, and high chopping frequency will be used. Try to get beat frequencies. Various damped oscillator models (like eq.2) as well as the duffing model (eq.3) will be used to explain the obtained data.

$$\ddot{x} = -\omega_0^2(1 + i\phi)x + F \quad (2)$$

$$\ddot{z} + \left(\frac{\omega_0}{Q}\right) \dot{z} + \omega_0^2 z + \beta z^3 = F_0 \sin(\omega_0 t) \quad (3)$$

#### 4.1 Sources of Noise

It becomes very important to have minimum noise to obtain accurate Q readout. As amplitude of the mode is being measured to get Q, QPD noise, which appears as random fluctuations in the signal of the op lev, will adversely affect the estimate of disk's amplitude. There is also a systematic error due to the presence of loss, or friction, in the system causing formation of heat gradient. If we try to measure the disk at 123K, then a heat gradient will mean we are actually measuring it at  $123K \pm \delta$  depending on the position in the disk. Since the friction increases away from the CTE zero crossing, this means the Q of our ringdown will be dominated by regions of the disk that are not at 123K. For example, if half the disk has a Q of  $10^9$  and the other half has a Q of  $10^6$ , very little energy will be dissipated in the  $10^9$  region, but we will observe the mode decay rapidly due to the energy lost in the  $10^6$  region. Therefore, we will claim a higher value of Q than would be theoretically possible. Of course, when we do the analysis we make a conservative estimate and put an upper bound on the loss, but since our goal is to measure high Q this systematic effect is a major limitation.

## 4.2 Lock-in Amplifier

Lock-in amplifier in combination with optical chopper is widely used to measure accurately the amplitude of a low frequency oscillating electrical signal under a very noisy environment. The lock-in amplifier takes the input signal from the QPD, along with the noise, as well as the reference signal from the chopper driver and puts them through a frequency mixer as shown in figure 5.

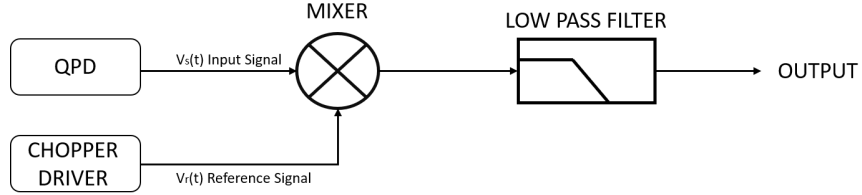

Figure 5: Block diagram of Lock-in Amplifier

The signal mixing is equivalent to a product of the two inputs in the time domain (eq.4 and eq.5) or sum and difference of underlying frequencies in the frequency domain.

$$Z(t) = V_s(t) \times V_r(t) \quad (4)$$

$$Z(t) = R[e^{i\{(\omega_s+\omega_r)t+\theta\}} + e^{i\{(\omega_s-\omega_r)t+\theta\}}] \quad (5)$$

An adjustable low pass filter of order  $n$  (eq.6) is applied to the result to cut out the undesired high frequencies. Additionally, a large DC component at the input can use up most of the lock-in's dynamic reserve, resulting in reduced measurement performance. Adding a high-pass filter on the input path will remove the DC offset.

$$H_n(\omega) = \left( \frac{1}{1 + i\omega\tau} \right)^n \quad (6)$$

Main characteristics of the result are determined by the filter bandwidth and filter order; the bandwidth is inversely proportional to the time constant. The shape of the filter can be adjusted by choosing its order; a higher-order leads to more ideal rectangular filter transfer function that blocks frequencies outside the filter bandwidth more efficiently but takes more time to settle causing a phase delay; a lower order filter has the advantage of causing less phase or temporal delay which helps when high speed requirements need to be met. Setting the filter bandwidth is a trade-off between SNR and time resolution, which needs to be investigated, as making it too large will lead to systemic measurement errors as more bandwidth corresponds to lot of averaging and hence limits the time-resolution. Another consideration is to have sufficient time resolution as the system is not stable on arbitrarily long timescales. The Q factor of the system will change, which implies a systematic lower Q measurement. The entire principle of mixing and low-pass filtering is called the phase sensitive detection or demodulation.

## 5 Timeline

1 week: Preparatory week; learn about experimental setup cryocooling and installing the silicon disc in the right position, preliminary ringdown measurements, electrostatic exciter, data acquisition process, look at previously stored data and previous reports, availability of additional hardware (ellipsometer, laser chopper, etc.) and testing their compatibility with software. Understanding of various damped oscillator models.

2-3 week (parallel) : Identification of noise sources in QPD measurement, identification and implementation of techniques of noise reduction. Building a lock-in amplifier simulation in MATLAB.

2-3 week (parallel) : Feasibility study of using ellipsometry to determine material properties in cryo conditions; if available hardware try testing its suitability.

4-5 week : Integrating laser chopper in laser path and use lock-in amplifiers; identification of beat frequencies. Data capture by driving the Si-disc to different levels of electro-static excitation and chopping frequencies.

5-6 week (parallel) : Ellipsometer data capture.

6-7 week (parallel) : Analysis of captured data finding a suitable model (damped simple harmonic oscillator, Duffing model, etc.)

8-9 week : Retake data by driving the Si-disc to different levels of electro-static excitation and chopping frequencies.

9-10 week (parallel) : Data analysis and model fitting.

11 week : Report writing and presentation.

## References

- [1] B.P. Abbott et al., *Observation of gravitational waves from a binary black hole merger*. Phys. Rev. Lett. 116 (2016) 061102.
- [2] R. Adhikari et al., *LIGO Voyager Upgrade: Design Concept* , LIGO-T1400226-v9, LIGO Scientific collaboration (2018).
- [3] Mariia Matiushechkina, Brittany Kamai and Aaron Markowitz, *Cool Coatings*. LIGO SURF Report (2017).
- [4] Mandy Katherine Cheung, Aaron Markowitz, Brittany Kamai, Rana X. Adhikari *Real-Time Temperature Monitoring for Mechanical Oscillators*. LIGO SURF Report (2018).
- [5] Zurich Instruments, *Principles of lock-in detection and the state of the art*. White paper (2016).
- [6] <https://space.mit.edu/3-questions-lisa-barsotti-on-the-new-and-improved-ligo/>
- [7] <https://www.space.com/ligo-observes-black-hole-merger-after-one-week.html>