

LASER INTERFEROMETER GRAVITATIONAL WAVE OBSERVATORY
- LIGO -
CALIFORNIA INSTITUTE OF TECHNOLOGY
MASSACHUSETTS INSTITUTE OF TECHNOLOGY

Technical Note	LIGO-T1900242-v2	2019/07/19
Active Reduction of Residual Amplitude Modulation in Free Space EOMs		
S.M.Aronson, A.Gupta, R.Adhikari, C.Cahillane		

California Institute of Technology
LIGO Project, MS 18-34
Pasadena, CA 91125
Phone (626) 395-2129
Fax (626) 304-9834
E-mail: info@ligo.caltech.edu

Massachusetts Institute of Technology
LIGO Project, Room NW22-295
Cambridge, MA 02139
Phone (617) 253-4824
Fax (617) 253-7014
E-mail: info@ligo.mit.edu

LIGO Hanford Observatory
Route 10, Mile Marker 2
Richland, WA 99352
Phone (509) 372-8106
Fax (509) 372-8137
E-mail: info@ligo.caltech.edu

LIGO Livingston Observatory
19100 LIGO Lane
Livingston, LA 70754
Phone (225) 686-3100
Fax (225) 686-7189
E-mail: info@ligo.caltech.edu

Contents

1	Introduction	2
1.1	LIGO	2
1.2	EOMs	2
1.3	Pound-Drever-Hall and Frequency Stabilization	2
2	Objective	3
3	Approach	3
3.1	Mathematical Motivation	3
3.2	Experimental Set-Up	4
4	Timeline	4
4.1	Week 1-2	4
4.2	Week 3-4	4
4.3	Week 5-6	5
4.4	Week 7-8	5
4.5	Week 9-10	5

1 Introduction

1.1 LIGO

The Laser Interferometer Gravitational-wave Observatory, also known as LIGO, is an earth-based network of two gravitational wave detectors located in the United States. The design is similar to a Michelson Interferometer, but with the addition of Fabry-Perot cavities along both arms. Due to the high finesse cavities in LIGO, it requires ultra-stable frequency lasers to make the precise measurements needed for gravitational wave detections. Utilizing an array of detectors, it is possible to better find the location of an event in the sky and study it.

1.2 EOMs

An Electro-Optic Modulator (or EOM for short) is one type of optical component used within LIGO. For our purpose, we use it as a phase modulator in a Pound-Drever-Hall (PDH) set-up for laser frequency stabilization. An EOM consists of an electro-optic crystal, which means the crystal's birefringence depends on an applied electric field, and a set of electrodes on the top and bottom of the crystal. This crystal has two principal axes which can have different refractive indices dependent on the electric field in that direction. The voltage difference of the electrodes creates an electric field across that axis of the crystal which then changes the index of refraction for the crystal in the respective axis. With two different indices of refraction for the principal axes, we essentially have a tunable waveplate. As we change the birefringence of the crystal, the light's phase is shifted in turn. Due to polarization misalignments, etalons, and other factors, EOM's in use as phase modulators also introduce residual amplitude modulation (RAM).

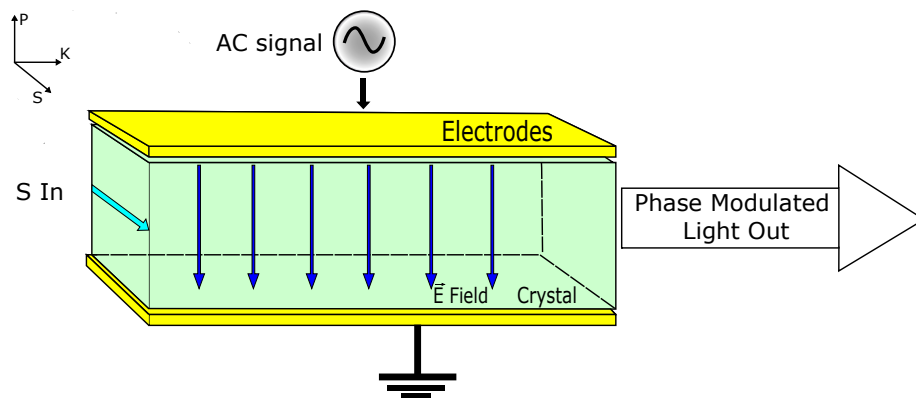

Figure 1: Experimental Set-up

1.3 Pound-Drever-Hall and Frequency Stabilization

The purpose of PDH is to lock the frequency of a laser to a cavity, or vice versa. This is usually done by measuring the power being reflected from the cavity and generating a

feedback signal to control the frequency of the laser or the length of the cavity. For light to resonate in the cavity its frequency must be an integer multiple of the cavity's free spectral range $\Delta\nu_{fsr} = c/2L$, where c is the speed of light and L is the length of the cavity. When the laser frequency is near resonance, the amount of light being reflected can be approximated as a linear function of the laser's frequency[1]. Phase modulation creates upper and lower sidebands, which when far from resonance can be treated as seeing the maximum reflection from the cavity. The photodetector sees the power from the superposition of these sidebands and the reflected carrier from the cavity. This power is converted to a voltage and then used as an error signal for locking.

Any RAM introduced by an EOM is fed through the experiment and is picked up on the photodetector. After the photodetector and the local oscillator's signals are mixed, this RAM introduces an offset on the signal being fed to the locking servo. This unwanted offset means the system is not at the frequency it expects. So instead of locking the laser's frequency to resonance, we unintentionally lock off-resonance reducing the effectiveness of the system. Any changes in RAM over time would change this offset uncontrollably leading to unpredictable behavior from the system.

2 Objective

Our goal is to use an EOM as a phase modulator and create an ultra-fast feedback mechanism by controlling the temperature and DC bias of the EOM to actively suppress RAM to the level of 1×10^{-5} . This will be done by using a free space EOM to phase modulate a beam, which will be partially picked off and sampled by a photodetector for use as our feedback signal to the temperature and DC bias control. The DC bias component influences the in-phase response 20 times more than the quadrature response, but the temperature control influences the quadrature response 5 times more than the in-phase response[2]. Working together, it should be feasible to have good suppression of both components over an extended period of time.

3 Approach

3.1 Mathematical Motivation

From our photodetector the amplitude modulated current for a given modulation frequency ω is given by

$$I(\omega_m) = -\sin(2\beta)\sin(2\gamma)|\epsilon_0|^2 J_1(M) \times \sin(\omega t) \sin(\Delta\phi + \Delta\phi_{DC}) [2].$$

Where β and γ represent polarization misalignments of the half-wave plates from the crystal's axes, ϵ_0 is the amplitude of the incoming laser field, $J_1(M)$ is the first order Bessel function with M being the difference in modulation depth between the ordinary and extraordinary axis, and $\Delta\phi + \Delta\phi_{DC}$ represents the crystals natural phase shift summed with the phase shift induced by the bias voltage. We can see that when this sum is zero or an integer multiple of π the \sin term will become zero yielding no RAM.

3.2 Experimental Set-Up

The set-up involves using feedback mechanisms for temperature and DC_{bias} suppression of RAM in an EOM being used as a phase modulator. As reported by [2] the in-phase RAM is much more effective at suppressing through the DC_{bias} voltage, and the quadrature component is better suppressed by the temperature control. The PD acts as our RAM signal which we then decompose into the in-phase component to feedback to the DC_{bias} port of the EOM, as well as a quadrature component which is used to control a heater in thermal contact with the EOM. The DC Servo's output is fed through a high voltage amplifier in order to reach the DC bias needed for RAM suppression in free space EOM's, which is usually a couple of hundred volts.

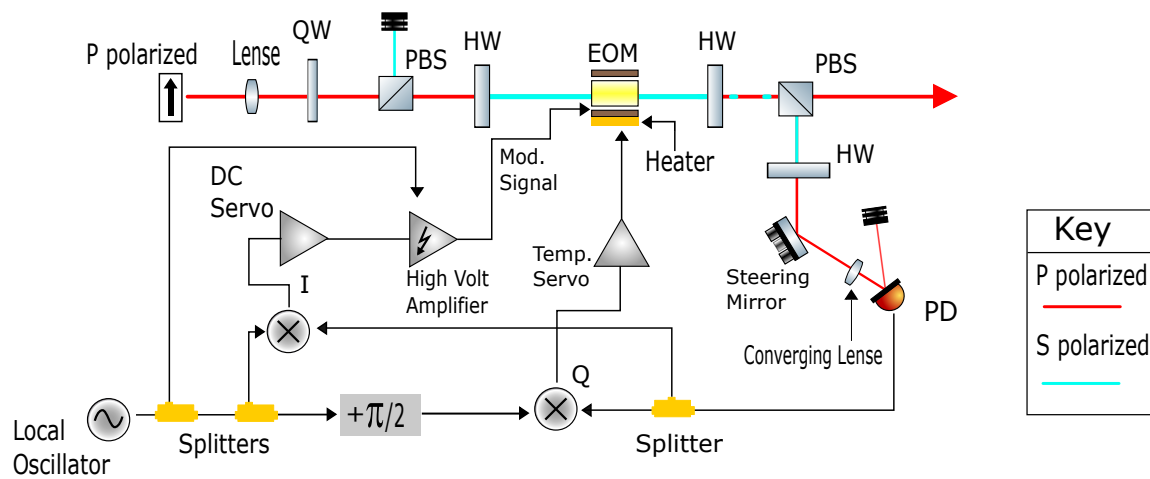

Figure 2: Experimental Set-up

4 Timeline

4.1 Week 1-2

The first two weeks we should be able to place optics on the table and achieve good alignment onto the photodetectors. Once we have the optical set-up in place, we can measure the signal strength from the PD to inform us on the requirements of the servos.

4.2 Week 3-4

Knowing the strength of signal to the servos, we can then investigate what form of servos we will use for feedback. These may be digital PID code, or analog circuits with amplification.

4.3 Week 5-6

After we know what form of servo we desire, we can either build the circuit or get/make the software we need. Once we have all the components for the electrical side of the feedback loop, we can fully construct the experiment.

4.4 Week 7-8

The next step will be to take the data analyzing the stabilization of RAM suppression over a set period of time. This hopefully will be actively kept under the level of 1×10^{-5} which is the level of suppression desired. If the RAM is above this threshold level, we will have to re-evaluate the components of our feedback loop and try to achieve the indicated level of RAM suppression.

4.5 Week 9-10

Here we will finish up the data acquisition and analysis. After which we will work for the remainder of our time on writing the final paper and working on a presentation of our findings.

References

- [1] Black, E. D. An introduction to Pound-Drever-Hall laser frequency stabilization. Am. J. Phys. 69, 79 - 87 (2001).
- [2] W. Zhang, M. J. Martin, C. Benko, J. L. Hall, J. Ye, C. Hagemann, T. Legero, U. Sterr, F. Riehle, G. D. Cole, and M. Aspelmeyer, "Reduction of residual amplitude modulation to 1×10^{-6} for frequency modulation and laser stabilization," Opt. Lett. 39, 1980-1983 (2014)