

# Pre-O3 PEM injections

Philippe Nguyen, Sharan Banagiri, Corey Austin, Kara Merfeld  
Anamaria Effler, Robert Schofield

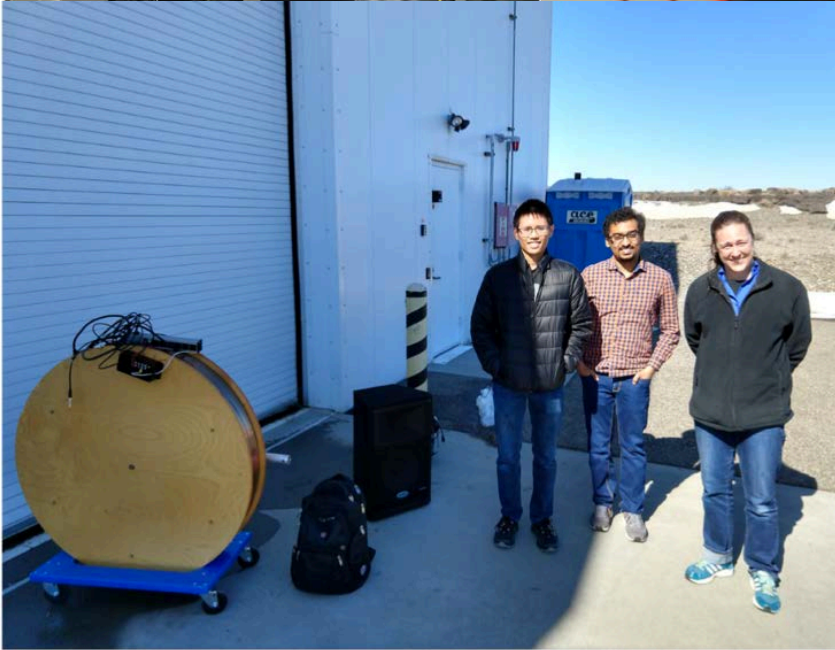
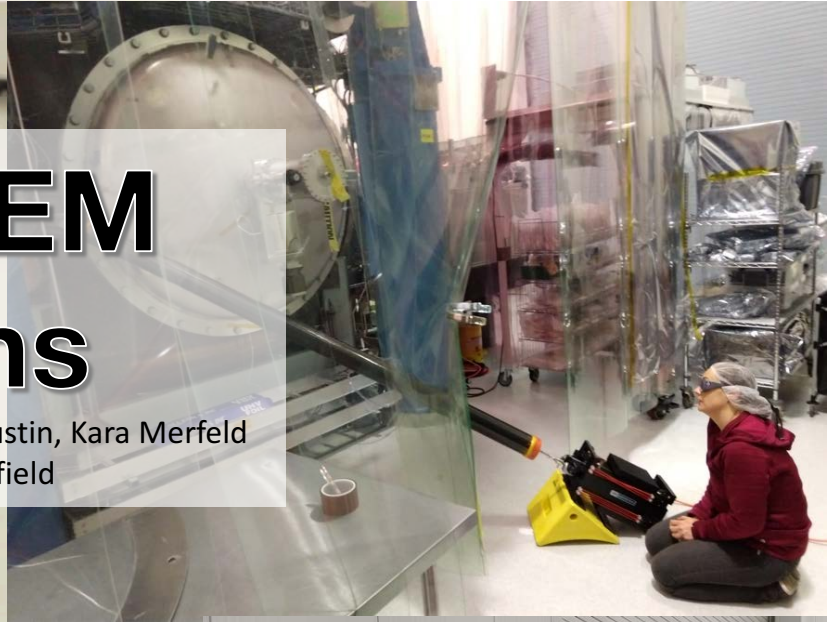
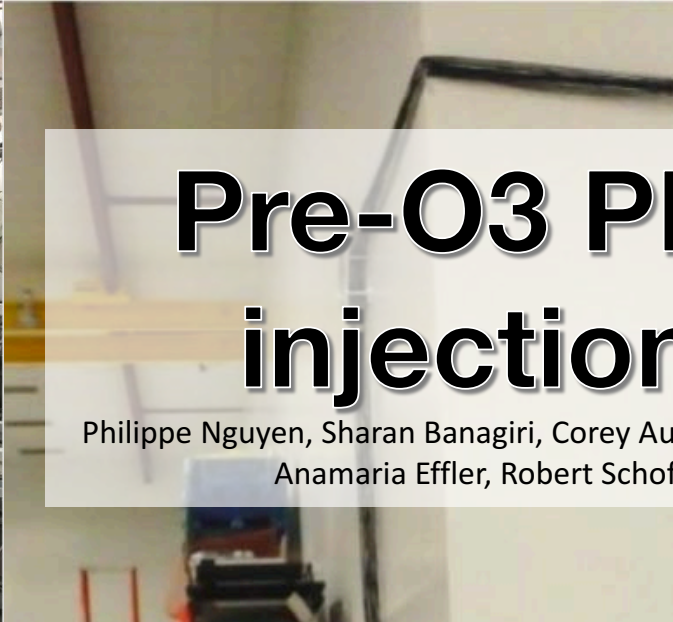

Reports until 19:23, Tuesday 28 May 2019

## H1 PEM

> EDIT > ADD COMMENT  [Link](#)

robert.schofield@LIGO.ORG - posted 19:23, Tuesday 28 May 2019 (49521)

### Pre-O3 PEM injection summary and links to individual logs

Philippe Nguyen, Corey Austin, Sharan Banagiri, Kara Merfeld, Anamaria Effler, Robert Schofield

O3 initial PEM injections took place mainly the weeks of March 25 at LLO and March 18 and April 15 at LHO. Hundreds of injections were made at tens of locations including acoustic, magnetic, shaking, impulse and RF injections (DTT files: <https://lhocds.ligo-wa.caltech.edu/exports/pem/19aMarPEMinjections/LHO>). A preliminary report was prepared, <https://alog.ligo-wa.caltech.edu/aLOG/index.php?callRep=47881>, we reference it below when it contains more detail than presented here.

#### A. Vibration coupling

##### **1) Worst site: LLO EX transmission monitor**

The large drops visible in LLO's range as anthropogenic vibration levels increase, are associated with the EX transmission monitor. The noise has a higher SNR in the pitch and yaw signals from the quad diodes than it does in DARM. Thus, the diodes witness the noise before it is combined with other noise in DARM. Candidates include scattering and servo noise. <https://alog.ligo-la.caltech.edu/aLOG/index.php?callRep=46147>

##### **2) Next worst sites: at LLO are EY and HAM5/6 and, at LHO, HAM5/6 and the PSL followed by EY**

Figure 1 indicates the sites at LHO and LLO where the ambient vibration level is estimated to make the greatest roughly linear contribution to DARM for each frequency. A rough summary of the LHO plot is that, the greatest ambient vibration contribution to DARM is in the HAM5/6 area below 100 Hz, and in the PSL area above 100 Hz. The rough summary for LLO is that the worst sites are HAM5/6 and EY, and both are a significant contribution to DARM below 100 Hz.

The plots are made by first calculating a coupling function (meters of DARM per meter of motion at sensor) for each sensor for each of multiple injections, and then producing a single coupling function for each sensor, using an algorithm to select the best of the multiple injections, usually the loudest relative to other sensors. The coupling function is multiplied by the ambient vibration level to produce an estimate of the ambient contribution to DARM. At each frequency in the plot, the sensor or sensor region with the highest estimated contribution to DARM is indicated by color, and the estimated contribution plotted.

## Introduction

### A. Vibration coupling, worst sites

- 1) LLO EX transmission monitor
- 2) Next worst sites at LLO are EY and HAM5/6 and, at LHO, HAM5/6 and the PSL
- 3) At both sites, HAM5/6 coupling is likely at the septum
- 4) EY coupling at LLO is likely in the manifold, at LHO, it may in the ETMY chamber
- 5) HAM5/6 coupling at the septum window?

*Other beam spots on LLO HAM6*

*OMC REFL beam not the cause of the main HAM5/6 scattering*

*HAM6 witness search at LLO*

- 6) IO jitter coupling at both sites
- 7) Comparison of EY and EX in-lock photos
- 8) Shaker injections at EY produce noise similar to some anthropogenic noise
- 9) Other vibration coupling

*Beamtube shaking*

*Coupling at LHO BS chamber and at the reduction flanges by the optical lever*

*48 Hz peak at LHO*

*Reduction of 58 Hz chiller peak at LHO:*

- 10) Vibration coupling not seen (at least 10 below DARM)

- 11) Coupling estimates from PEM injections correctly predict environmental coupling

*LLO DARM glitch near S190510g is correctly predicted from PEM injection coupling functions.*

*Range reduction from LHO HVAC is roughly predicted from estimates for HAM5/6.*

*Range reduction from rain at LHO is roughly consistent with PEM coupling functions*

*Range reduction from wind at LHO is roughly consistent with PEM coupling functions.*

### B. Magnetic Coupling

### C. RF Coupling

### D. Site activities

## Acoustic

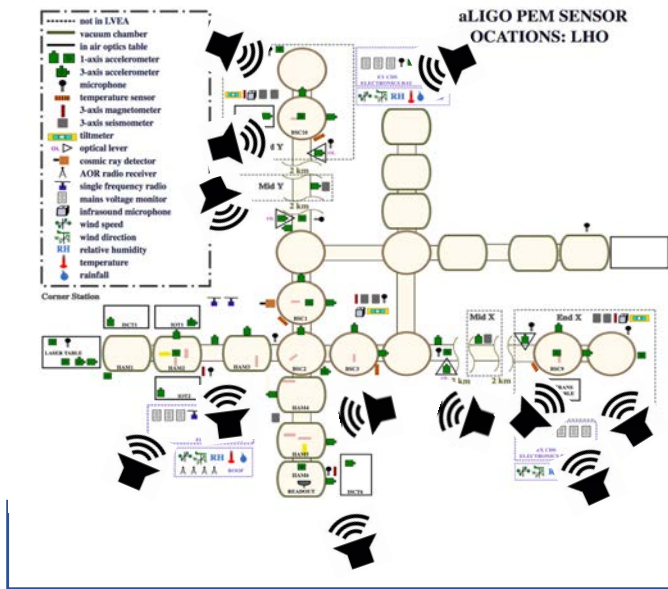

## Magnetic

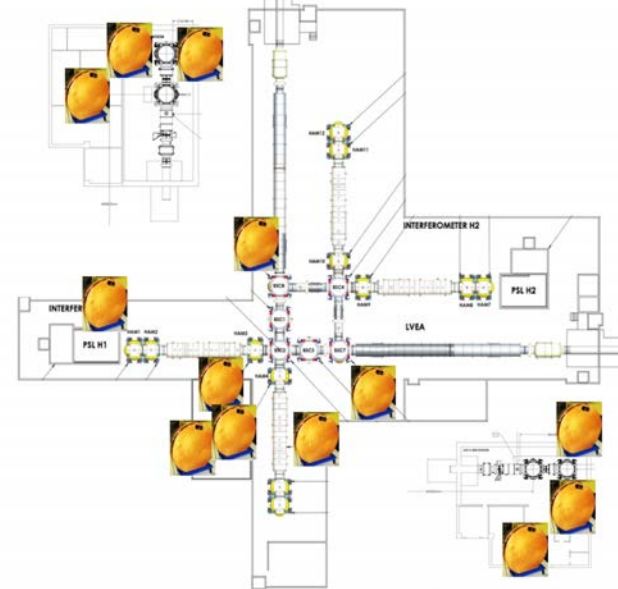

## Shaker

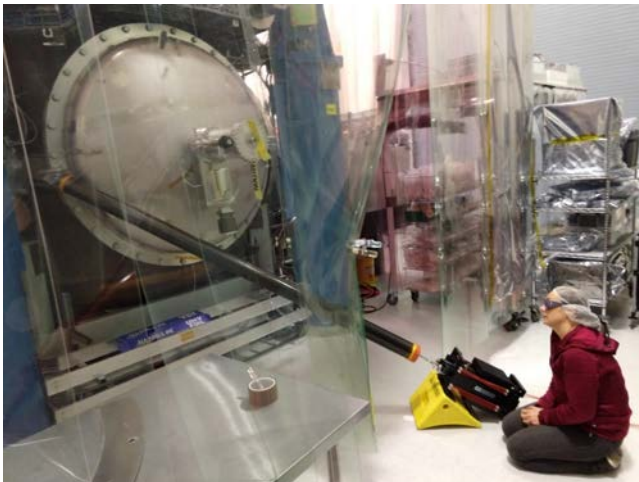

## Radio



## Impulse



# PEM.LIGO.ORG

## PEM Central



**LHO**  
**PEM CHANNELS**  
INTERACTIVE MAP



**LLO**  
**PEM CHANNELS**  
INTERACTIVE MAP



**PEM CHANNELS**  
**COUPLING FUNCTIONS**



**COUPLING FUNCTIONS ARCHIVE**



**LigoCAM LHO**



**LigoCAM LLO**



**RF SCANNER LHO**



**RF SCANNER LLO**



**LHO CDS PEM**  
**EXPORTS DIRECTORY**



**LLO CDS PEM**  
**EXPORTS DIRECTORY**



**ROBERT'S**  
**ENVIRONMENTAL**  
**INFLUENCES**  
PAGE



**PEM**  
**PROJECTS**



**ENVIRONMENTAL**  
**STUDIES**  
WIND, SEISMIC, ETC

## Introduction

### A. Vibration coupling

#### 1) Worst site: LLO EX transmission monitor

2) Next worst sites at LLO are EY and HAM5/6 and, at LHO, HAM5/6 and the PSL

3) At both sites, HAM5/6 coupling is likely at the septum

4) EY coupling at LLO is likely in the manifold, at LHO, it may in the ETMY chamber

5) HAM5/6 coupling at the septum window?

*Other beam spots on LLO HAM6*

*OMC REFL beam not the cause of the main HAM5/6 scattering*

*HAM6 witness search at LLO*

6) IO jitter coupling at both sites

7) Comparison of EY and EX in-lock photos

8) Shaker injections at EY produce noise similar to some anthropogenic noise

9) Other vibration coupling

*Beamtube shaking*

*Coupling at LHO BS chamber and at the reduction flanges by the optical lever*

*48 Hz peak at LHO*

*Reduction of 58 Hz chiller peak at LHO:*

10) Vibration coupling not seen (at least 10 below DARM)

11) Coupling estimates from PEM injections correctly predict environmental coupling

*LLO DARM glitch near S190510g is correctly predicted from PEM injection coupling functions.*

*Range reduction from LHO HVAC is roughly predicted from estimates for HAM5/6.*

*Range reduction from rain at LHO is roughly consistent with PEM coupling functions*

*Range reduction from wind at LHO is roughly consistent with PEM coupling functions.*

### B. Magnetic Coupling

### C. RF Coupling

### D. Site activities

**The main source of the anthropogenic drops in LLO range is associated with EX transmission monitor**

Corey, Anamaria, Robert

*Summary: 1) The big drops in LLO range with anthropogenic vibrations are strongly correlated with what looks like scattered light on the TMX diodes. 2) The range-correlated noise has higher SNR in the TMX diode signals than in DARM, indicating that the TMX diodes witness the noise before it is combined with other noise in DARM.*

The PEM team has been working on the question of whether HAM5/6 and EY are the main vibration coupling sites at LLO. EY is certainly an important vibration coupling site that contributes to drops in range. Shaking at EY can produce arches similar to those from some of the daytime noise ( <https://alog.ligo-la.caltech.edu/aLOG/index.php?callRep=46089> ), and thunder coupling at EY may have contributed to S190510g ( <https://alog.ligo-la.caltech.edu/aLOG/index.php?callRep=46025> ). The HAM5/6 area is also an important coupling site (e.g. <https://alog.ligo-la.caltech.edu/aLOG/index.php?callRep=46149> ), and may be due to scattering from the septum window ( <https://alog.ligo-wa.caltech.edu/aLOG/index.php?callRep=48886> ) But there is a third noise source that more closely correlates with the anthropogenic range drops than the noise produced at EY or HAM5/6: noise that is evident on the EX transmission monitor photodiodes.

The transmission monitors have been implicated before. In the fall, when DARM was offloaded at upper stages of ETMY, scattering was visible on TMY diodes, now it is offloaded at upper stages of the ETMX suspension. During PEM injections at LLO we noted a “mystery” scattering in spectrograms that we couldn’t explain by shaking the vacuum enclosure. Andy and other DetChar members have noted scattering associated with TMX on multiple occasions.

The main points here are, first, that the noise registered on the TMX diodes is the worst anthropogenic-vibration driven noise at LLO, worse than noise produced at HAM5/6 or ETMY, as judged by the detrimental effect on range over multiple days scattered across O3. And, second, that the diodes witness the range-correlated noise with higher SNR than it is seen in DARM and so the diodes are “upstream” from DARM, that is, see the noise before the SNR is reduced by other noise in DARM.

Figure 1 shows that the big workday drops in range are nearly perfectly correlated with noise in TMX photodiodes, noise that has a higher SNR than the noise in DARM. The other scattering noise (such as from EY) is visible in the spectrograms, but it does not correlate nearly as well with the range drops. The TMX noise is almost continuous, and only shows in DARM when the apparent scattering shelf reaches the most sensitive band in DARM.

In order for the SNR to be bigger on the TMX diodes (assuming that the diodes are seeing scattered light), the fraction of scattered light must be much greater at the diode than in DARM. Otherwise we could detect gravitational waves better with the TMX diode than with the OMC diodes. So, it is likely that the entire parasitic cavity is behind the EX test mass. One possibility is that there is a parasitic cavity between the TMX and ETMX (or less likely the annular RMX). Another is that the “cavity” is within the TMX itself, modulated by the entry

# Two types of scatter-like noise

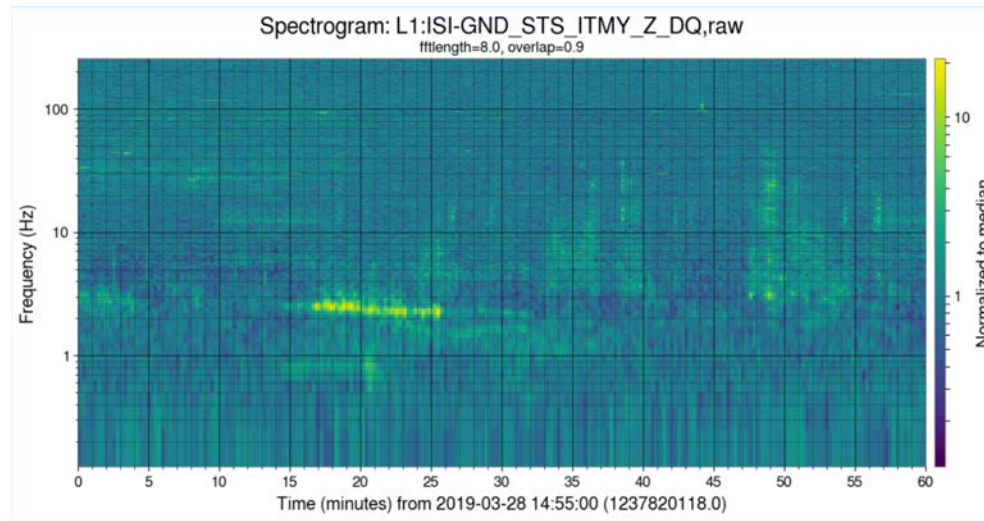
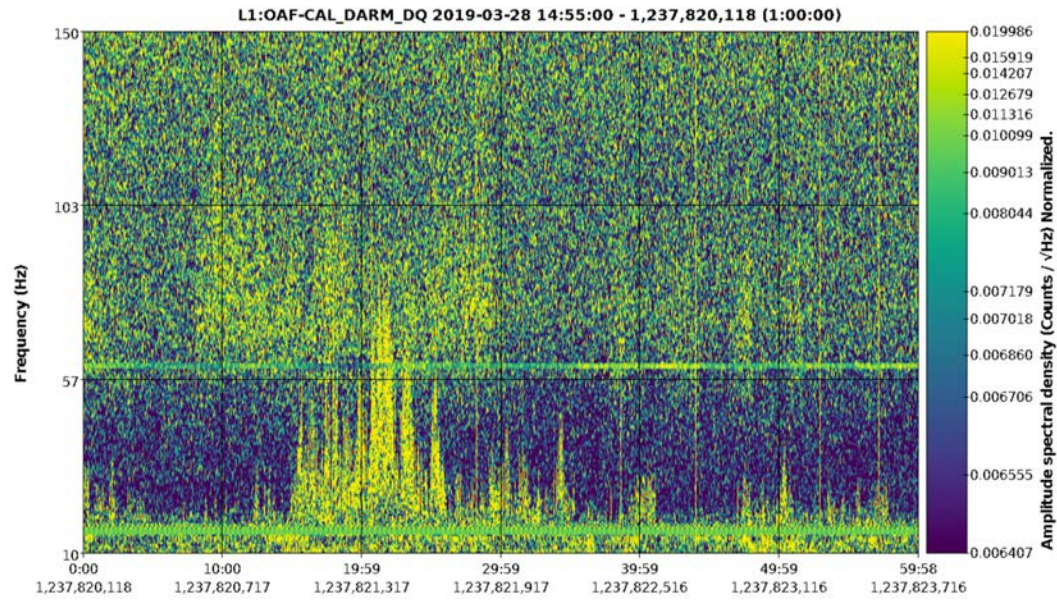



April 27

May 17

L1 DARM  
4 hours

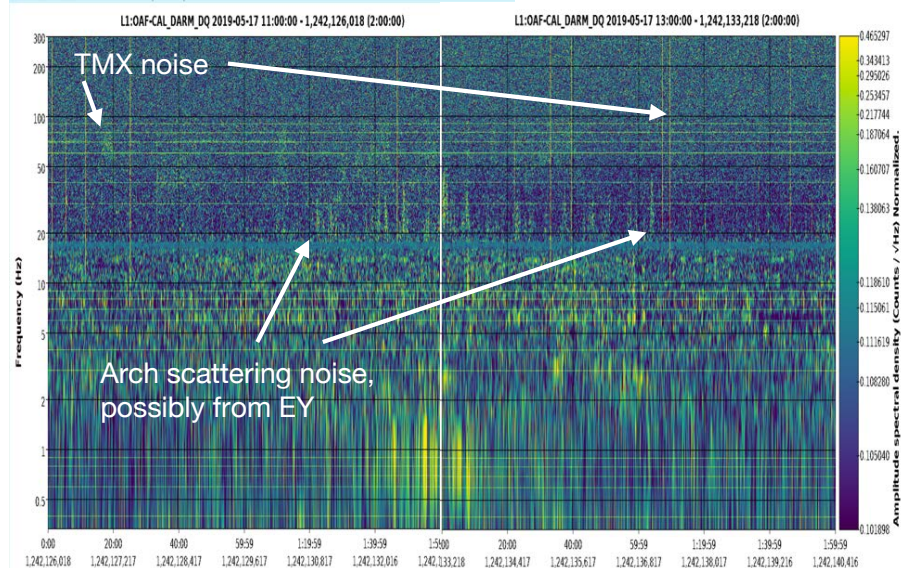
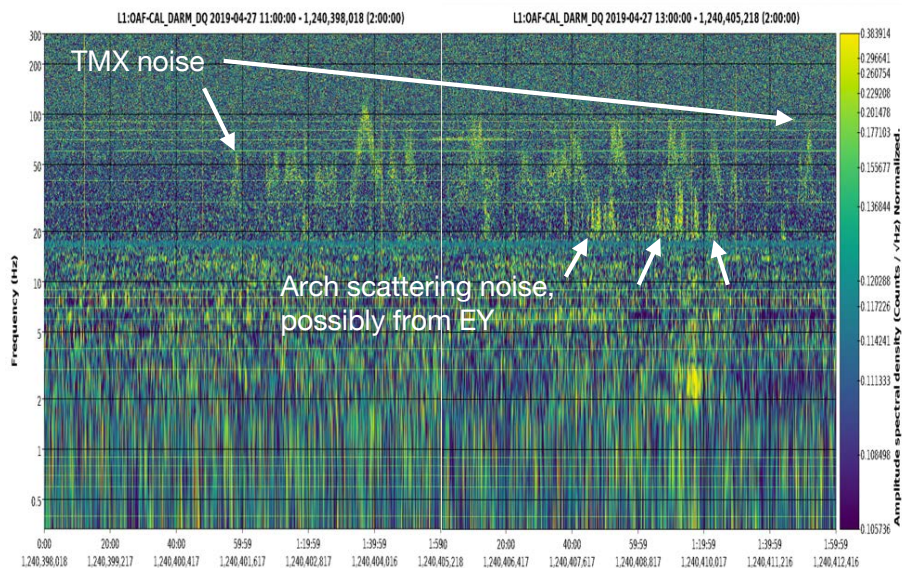

TMX noise: L1  
X\_TR\_A\_YAW  
signal from  
transmission  
monitor quad  
photodiode

L1 range

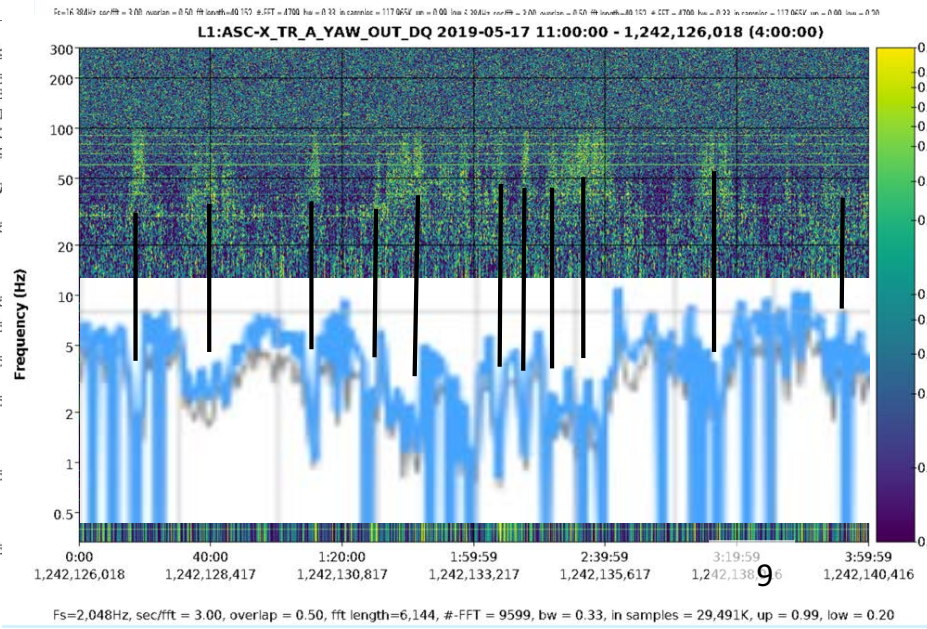
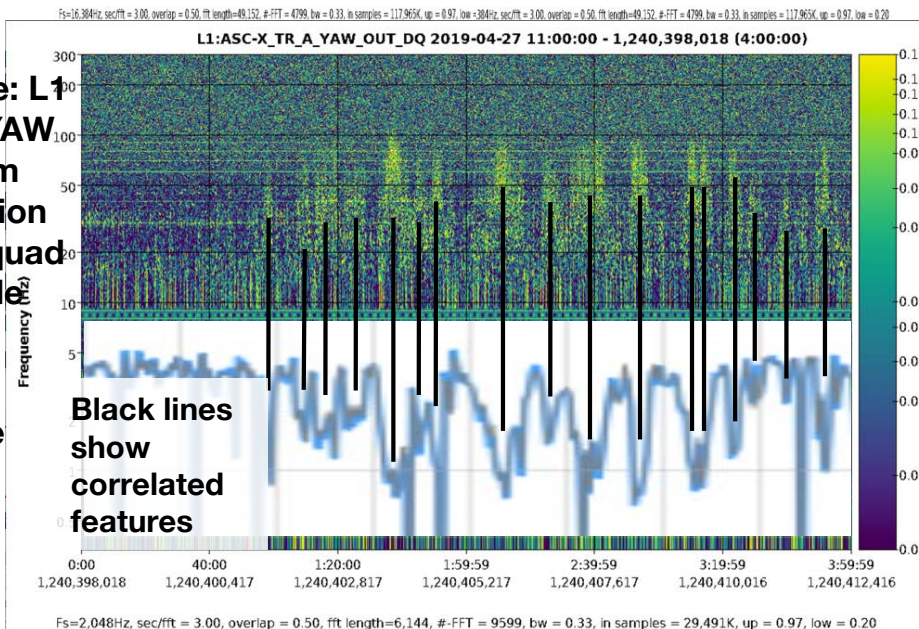

Fs=2,048Hz, sec/fft = 3.00, overlap = 0.50, fft length=6,144, #-FFT = 9599, bw = 0.33, in samples = 29,491K, up = 0.97, low = 0.20

Fs=2,048Hz, sec/fft = 3.00, overlap = 0.50, fft length=6,144, #-FFT = 9599, bw = 0.33, in samples = 29,491K, up = 0.99, low = 0.20

L1 DARM  
4 hours

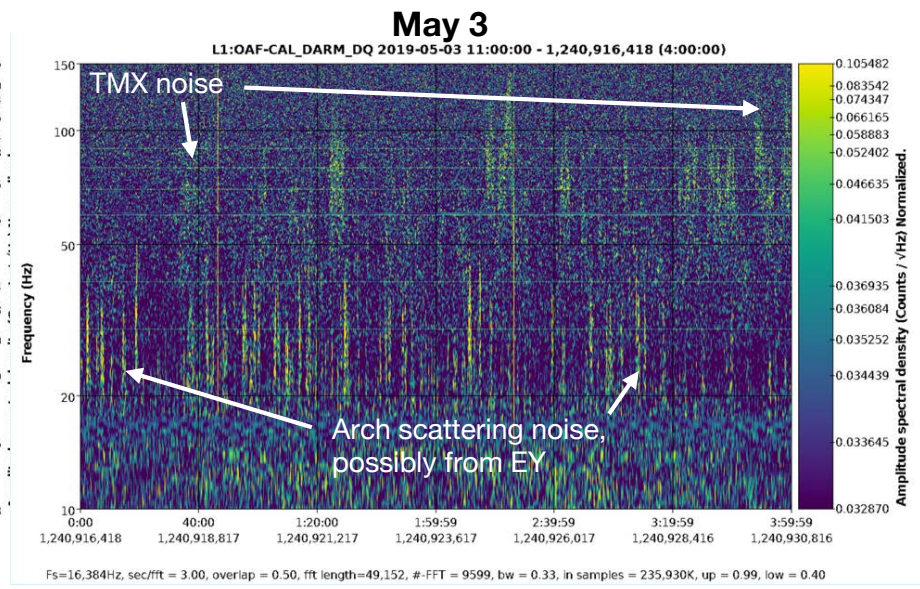
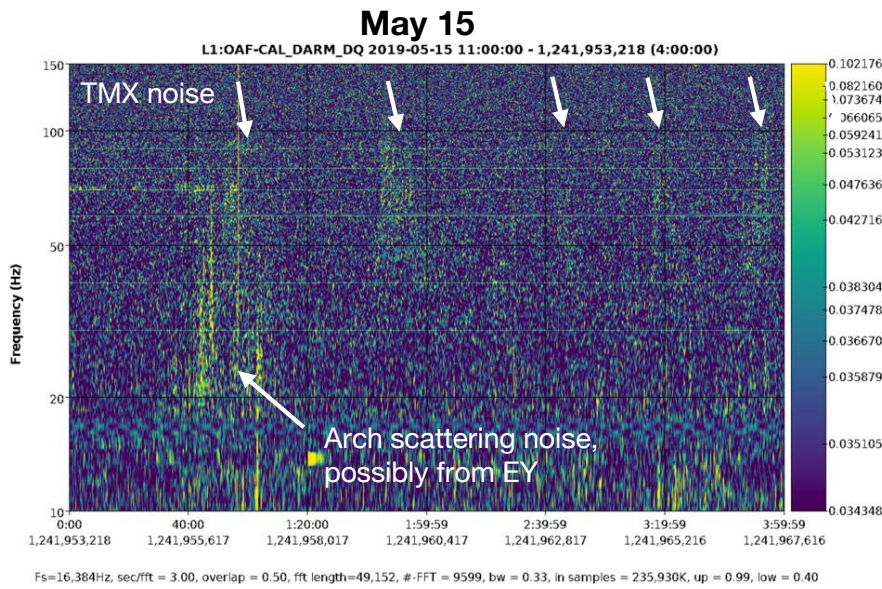

TMX noise: L1  
X\_TR\_A\_NSUM  
signal from  
transmission  
monitor quad  
photodiode

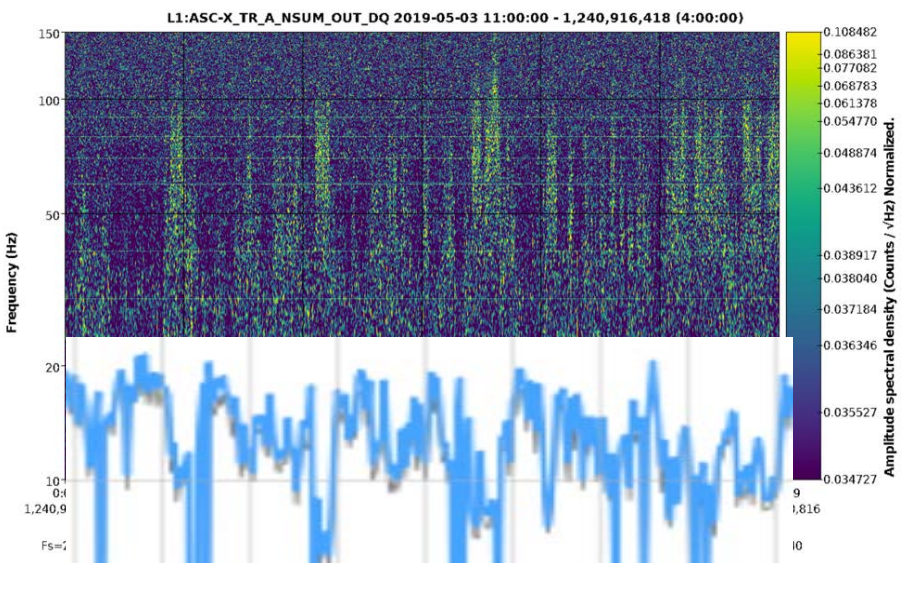
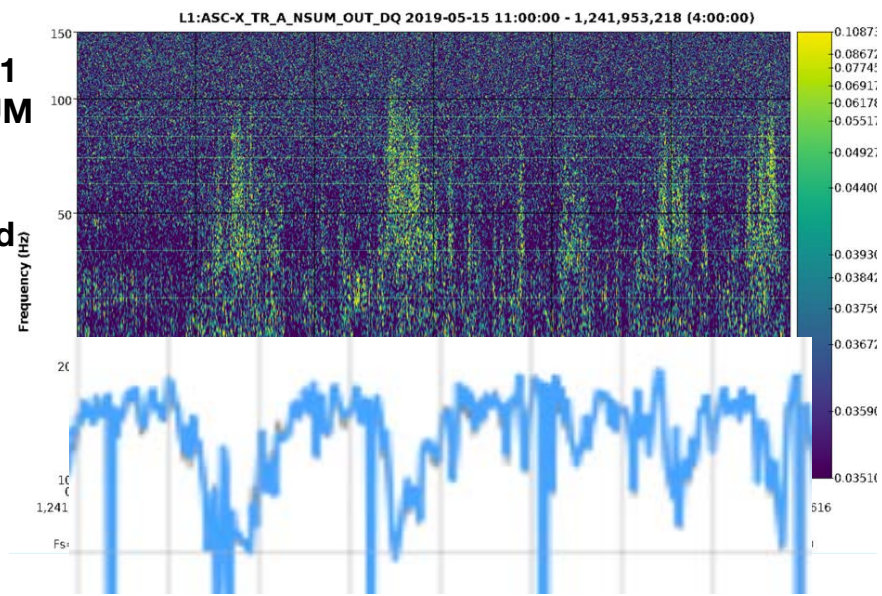

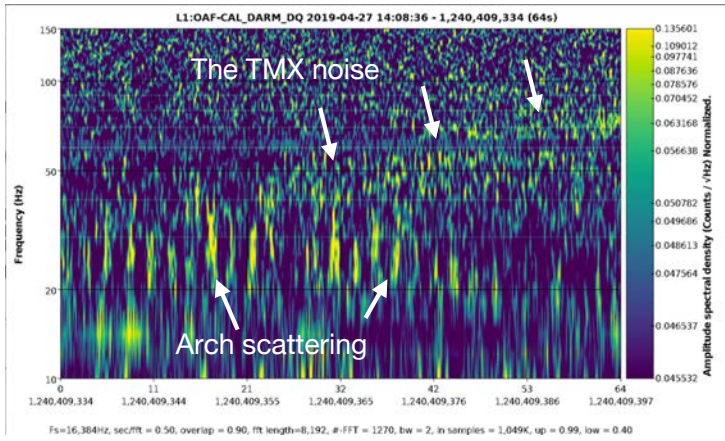

Spectrogram

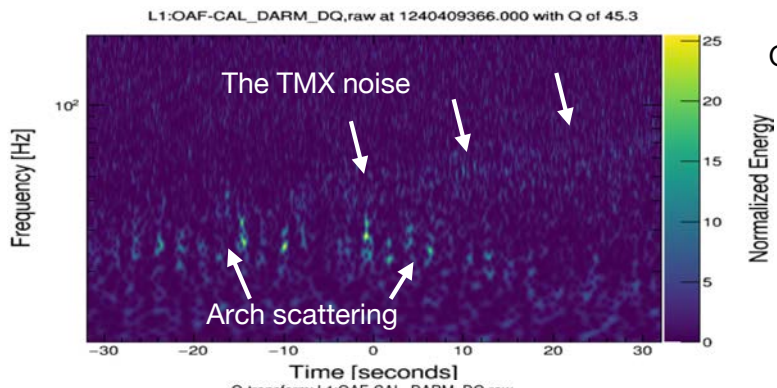
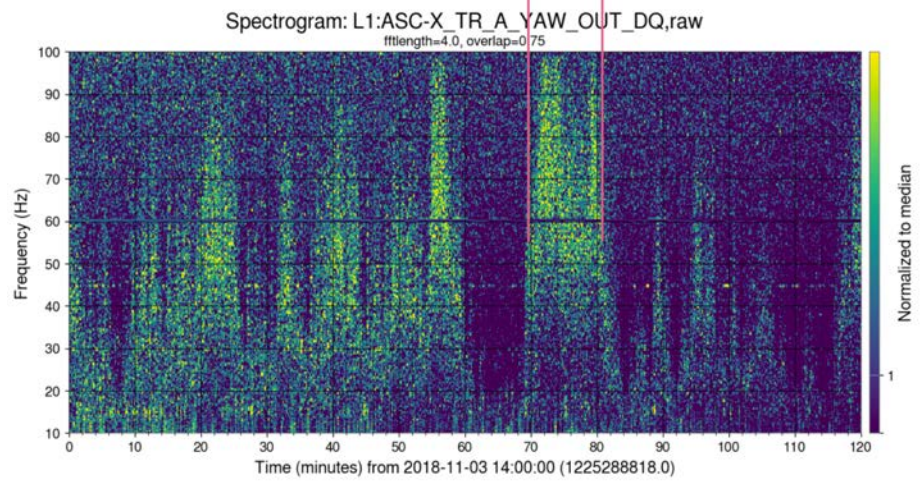
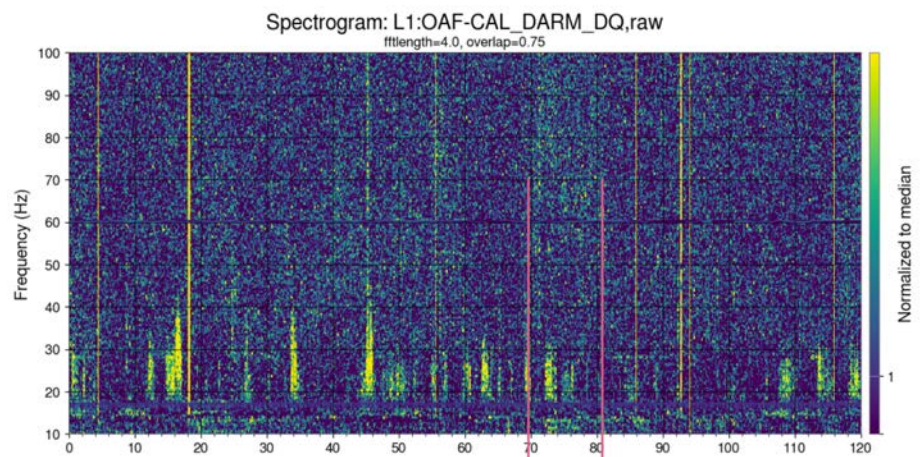

Omega scan

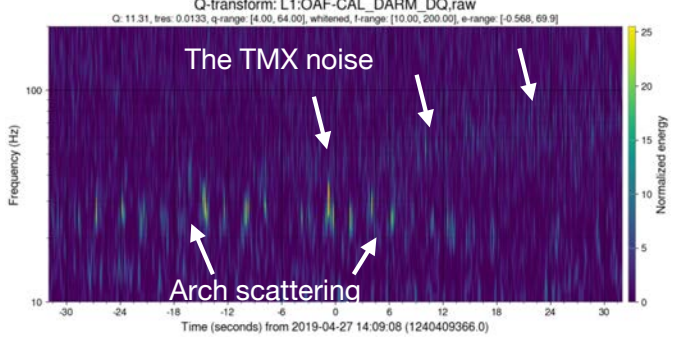

Q-transform  
Same settings

Was there early Nov!

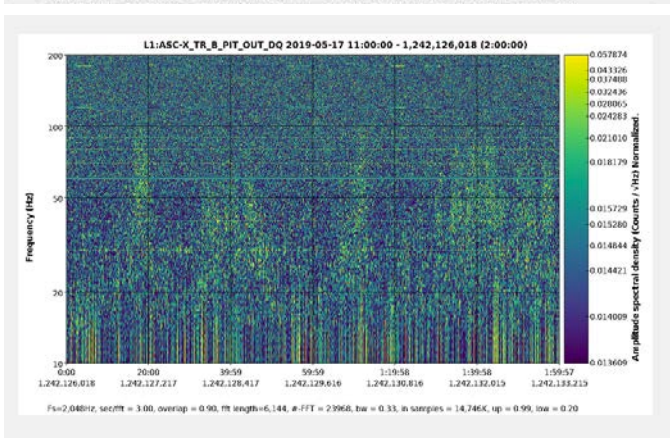
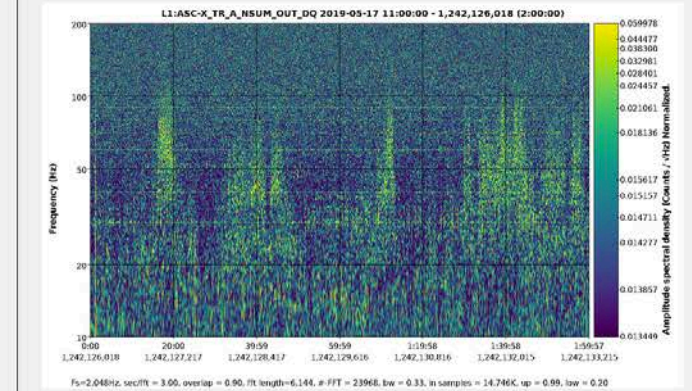
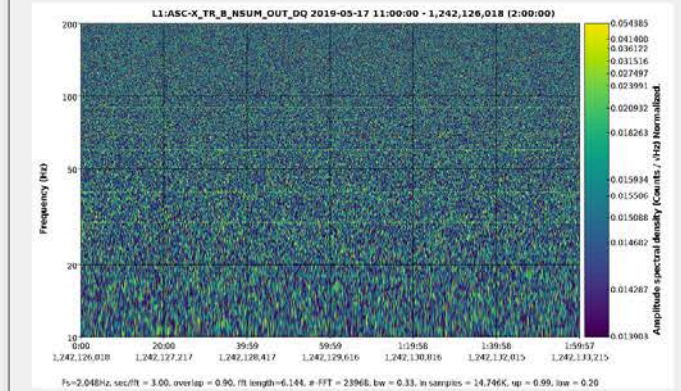
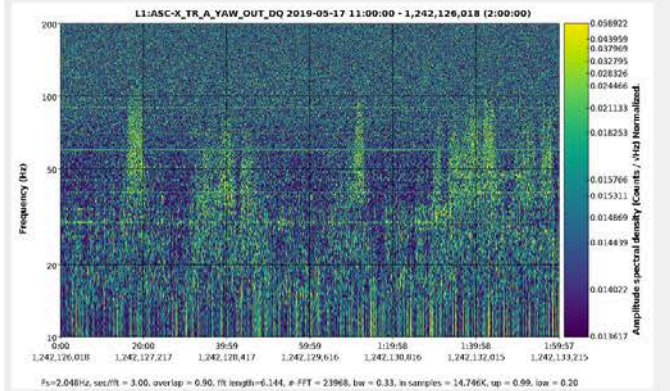
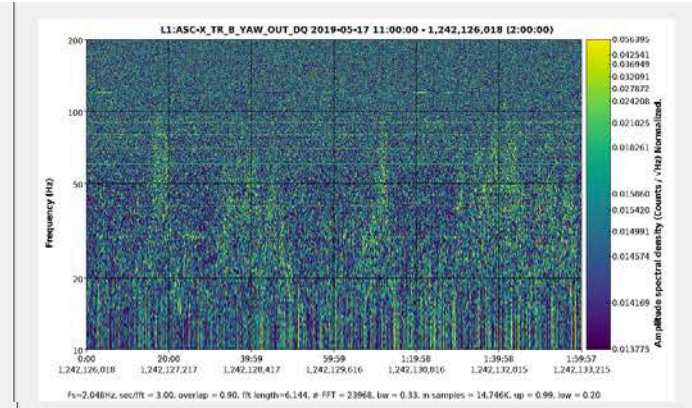
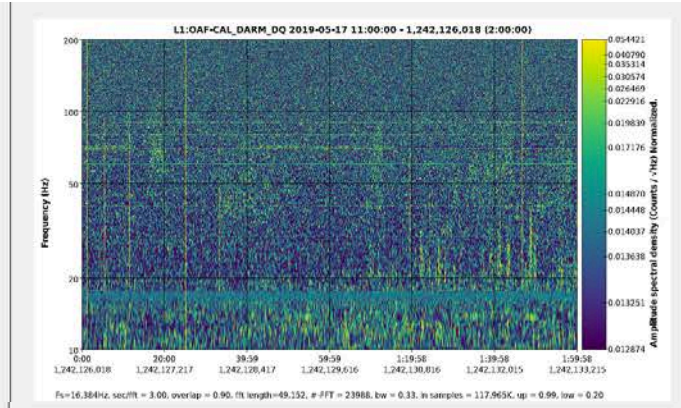
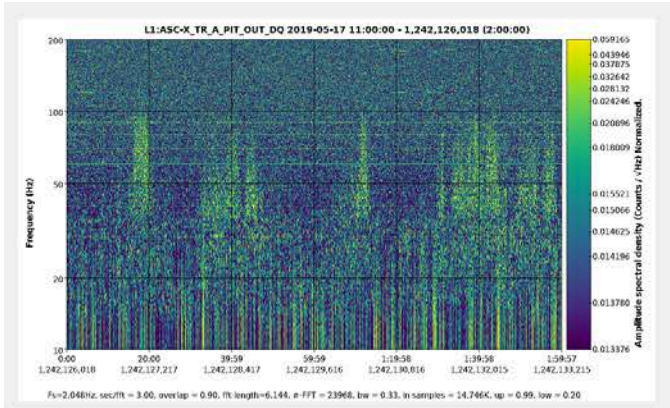

Why does X TR-B NSUM not see the noise?

# Spectral look

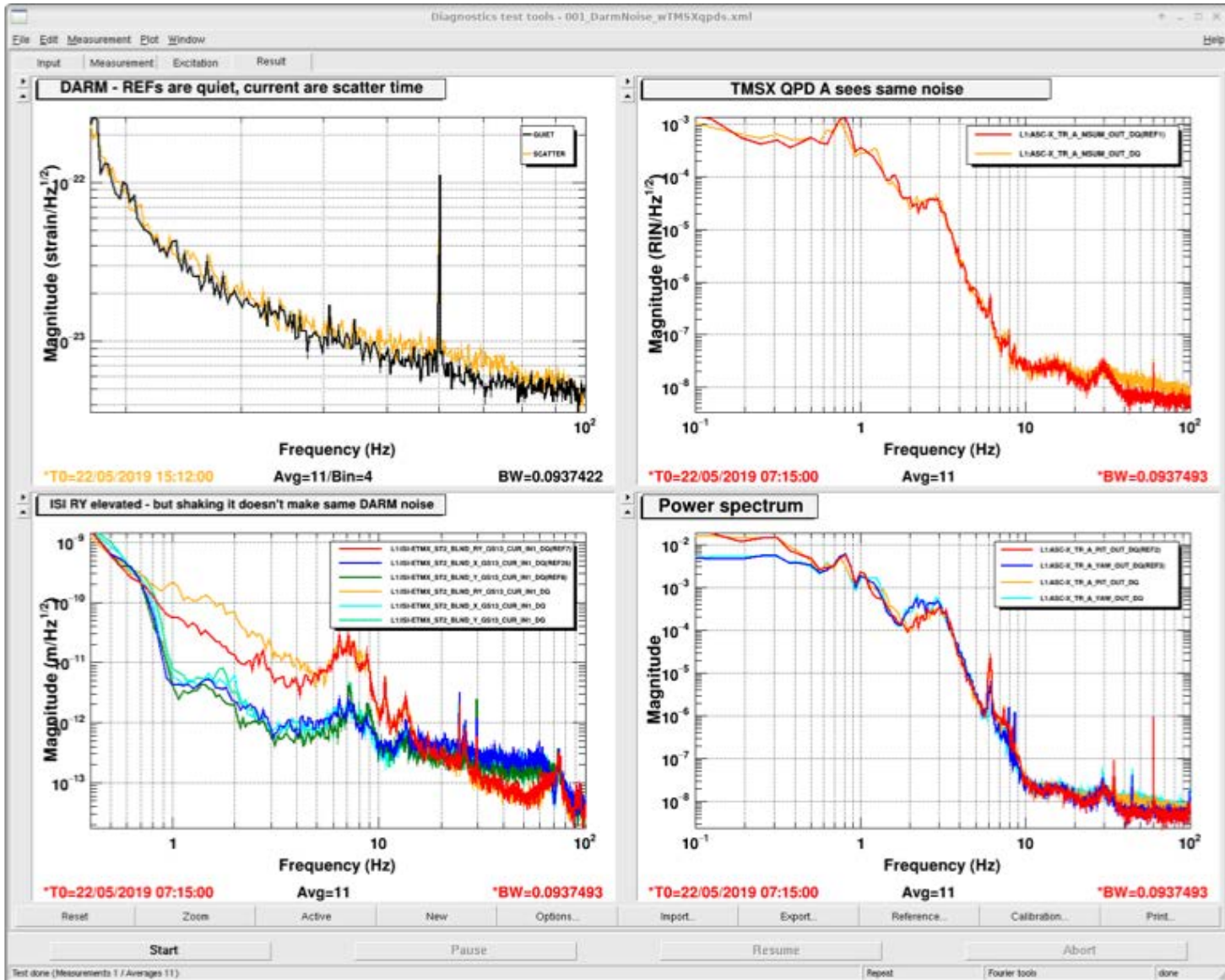

# Not seen in drive signals

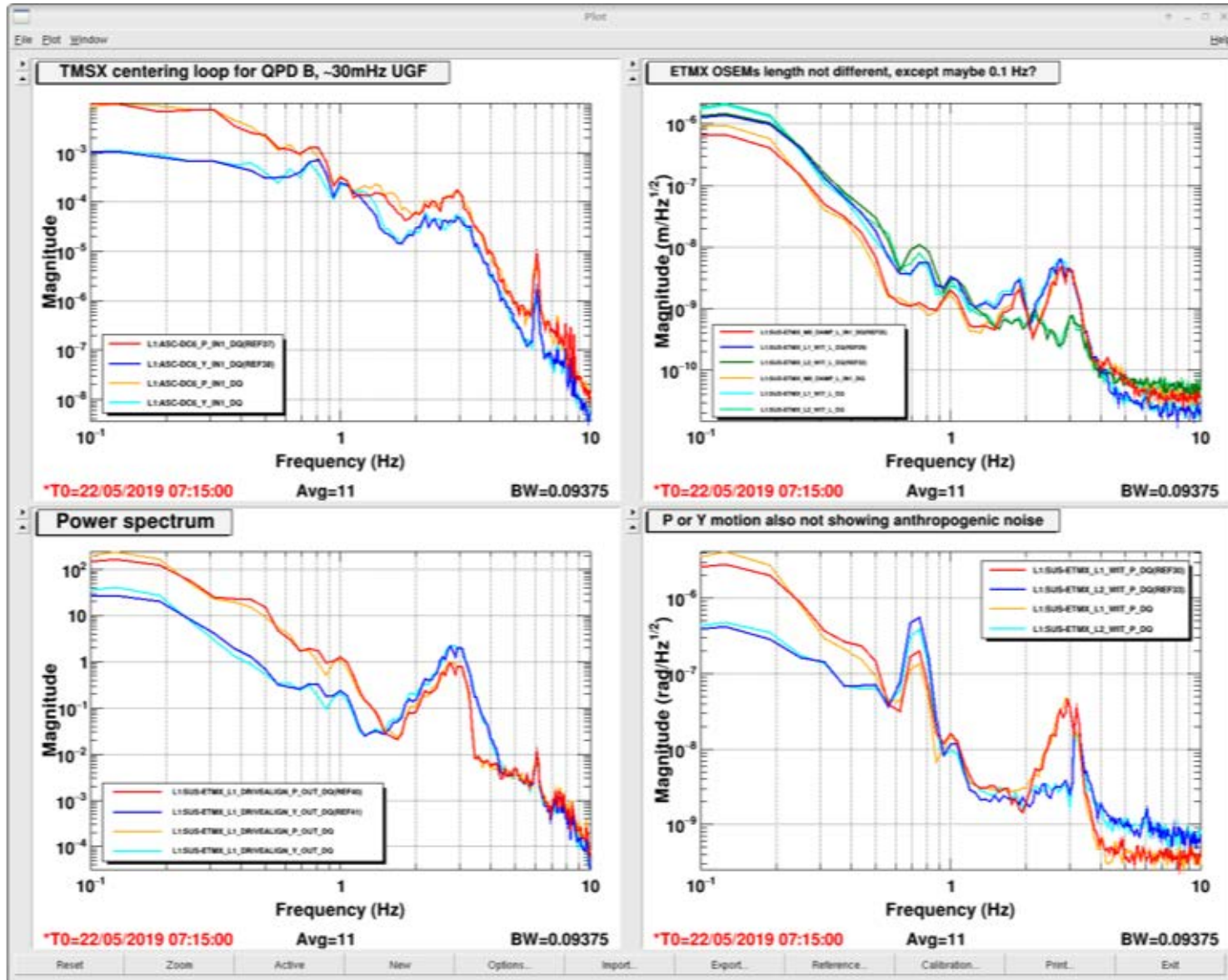

# TMS 1-5 Hz injections don't reproduce noise

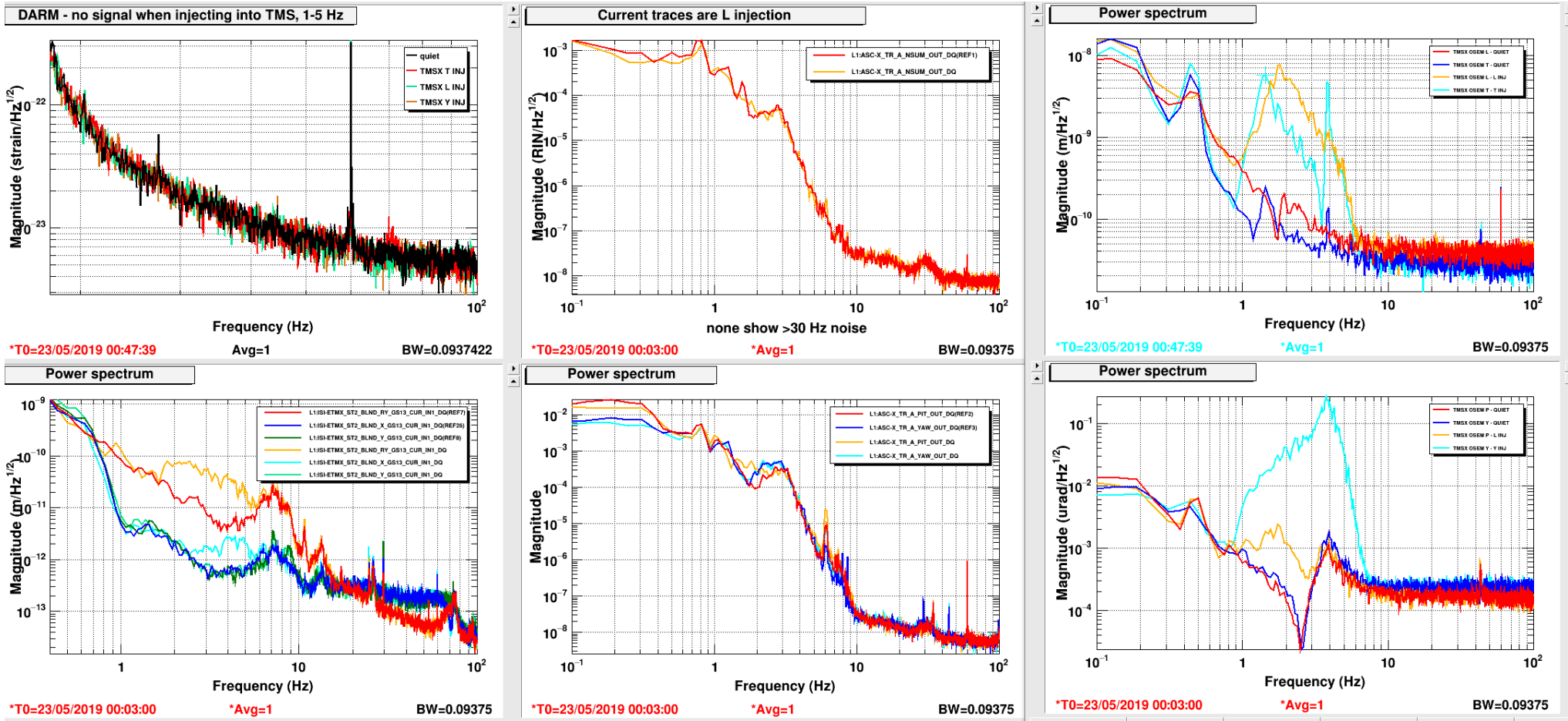

Neither does ISI or wall injection – except maybe a sweep we have to redo

## Introduction

### A. Vibration coupling

1) Worst site: LLO EX transmission monitor

2) Next worst sites at LLO are EY and HAM5/6 and, at LHO, HAM5/6 and the PSL

3) At both sites, HAM5/6 coupling is likely at the septum

4) EY coupling at LLO is likely in the manifold, at LHO, it may in the ETMY chamber

5) HAM5/6 coupling at the septum window?

*Other beam spots on LLO HAM6*

*OMC REFL beam not the cause of the main HAM5/6 scattering*

*HAM6 witness search at LLO*

6) IO jitter coupling at both sites

7) Comparison of EY and EX in-lock photos

8) Shaker injections at EY produce noise similar to some anthropogenic noise

9) Other vibration coupling

*Beamtube shaking*

*Coupling at LHO BS chamber and at the reduction flanges by the optical lever*

*48 Hz peak at LHO*

*Reduction of 58 Hz chiller peak at LHO:*

10) Vibration coupling not seen (at least 10 below DARM)

11) Coupling estimates from PEM injections correctly predict environmental coupling

*LLO DARM glitch near S190510g is correctly predicted from PEM injection coupling functions.*

*Range reduction from LHO HVAC is roughly predicted from estimates for HAM5/6.*

*Range reduction from rain at LHO is roughly consistent with PEM coupling functions*

*Range reduction from wind at LHO is roughly consistent with PEM coupling functions.*

### B. Magnetic Coupling

### C. RF Coupling

### D. Site activities



## L1 Vibrational - Estimated Ambient Highest coupling factor at each frequency across all channels)

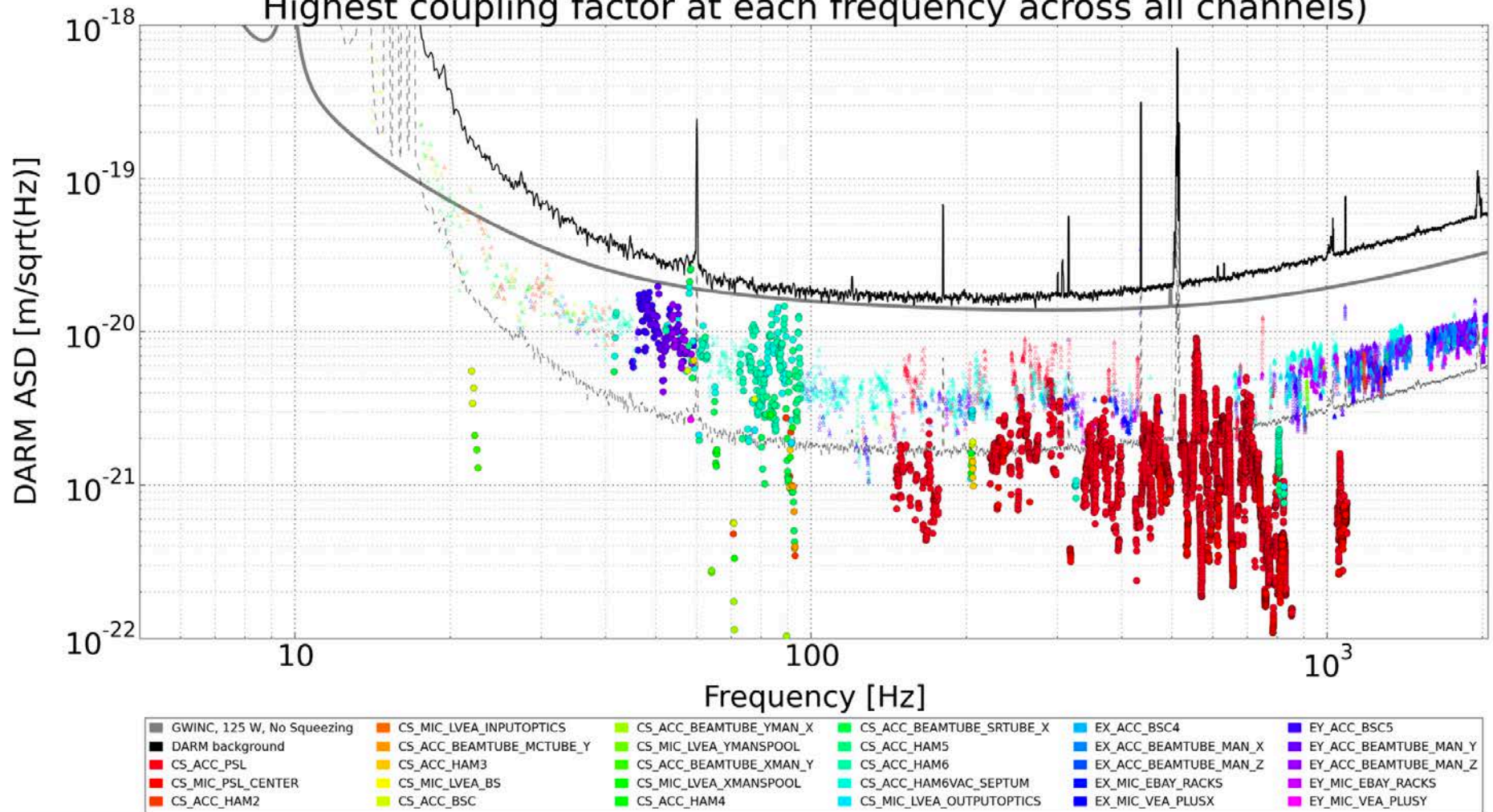

Ambient estimates are made by multiplying coupling factors by injection-free sensor levels. CIRCLES indicate estimates from measured coupling factors, i.e. where the injection signal was seen in the sensor and in DARM. TRIANGLES represent upper limit coupling factors, i.e. where a signal was seen in the sensor but not in DARM. For some channels, at certain frequencies the ambient estimates are upper limits because the ambient level is below the sensor noise floor.

# H1 Vibrational - Estimated Ambient Highest coupling factor at each frequency across all channels)

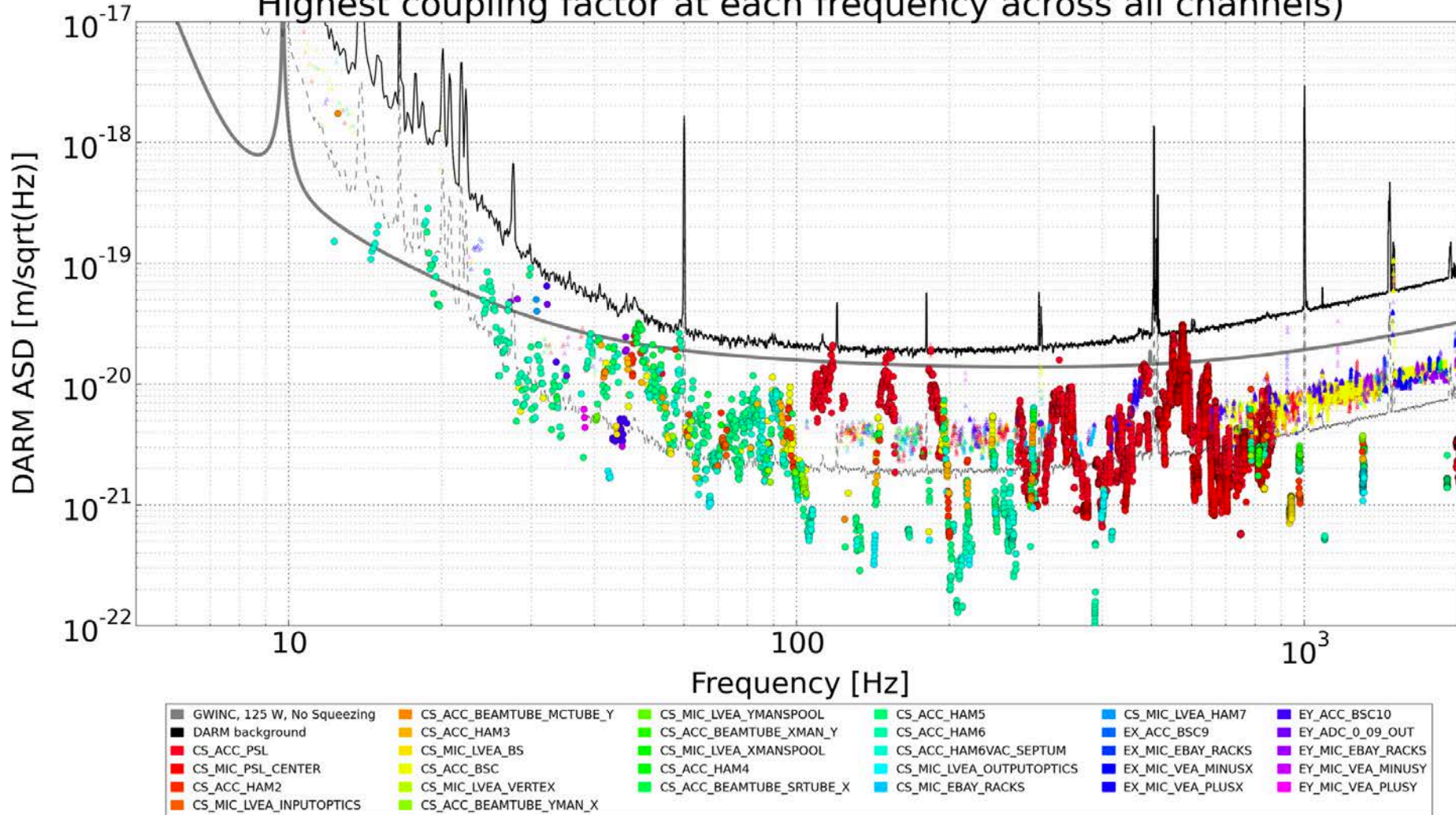

Ambient estimates are made by multiplying coupling factors by injection-free sensor levels. CIRCLES indicate estimates from measured coupling factors, i.e. where the injection signal was seen in the sensor and in DARM. TRIANGLES represent upper limit coupling factors, i.e. where a signal was seen in the sensor but not in DARM. For some channels, at certain frequencies the ambient estimates are upper limits because the ambient level is below the sensor noise floor.

## Introduction

### A. Vibration coupling

- 1) Worst site: LLO EX transmission monitor
- 2) Next worst sites at LLO are EY and HAM5/6 and, at LHO, HAM5/6 and the PSL
- 3) **At both sites, HAM5/6 coupling is likely at the septum**
- 4) EY coupling at LLO is likely in the manifold, at LHO, it may in the ETMY chamber
- 5) HAM5/6 coupling at the septum window?

*Other beam spots on LLO HAM6*

*OMC REFL beam not the cause of the main HAM5/6 scattering*

*HAM6 witness search at LLO*

- 6) IO jitter coupling at both sites
- 7) Comparison of EY and EX in-lock photos
- 8) Shaker injections at EY produce noise similar to some anthropogenic noise
- 9) Other vibration coupling

*Beamtube shaking*

*Coupling at LHO BS chamber and at the reduction flanges by the optical lever*

*48 Hz peak at LHO*

*Reduction of 58 Hz chiller peak at LHO:*

- 10) Vibration coupling not seen (at least 10 below DARM)
- 11) **Coupling estimates from PEM injections correctly predict environmental coupling**
  - LLO DARM glitch near S190510g is correctly predicted from PEM injection coupling functions.*
  - Range reduction from LHO HVAC is roughly predicted from estimates for HAM5/6.*
  - Range reduction from rain at LHO is roughly consistent with PEM coupling functions*
  - Range reduction from wind at LHO is roughly consistent with PEM coupling functions.*

### B. Magnetic Coupling

### C. RF Coupling

### D. Site activities

**Impulse injection techniques point towards septum as being main source of HAM5/6 scattering at LLO and at LHO**

Sharan Banagiri, Corey Austin, Philippe Nguyen, Anamaria Effler, Robert Schofield

*Summary: For impulse injections from multiple locations, signals from accelerometers mounted on the HAM5/6 septum are the best match to DARM in arrival time, have the most consistent amplitude ratios with DARM, and have the most similar frequency structure to the effect of the impulse in DARM. Together with shaking data, this suggests that the septum is the dominant vibration coupling site in the LVEA at both sites. These vacuum enclosure impulse techniques promise to be a useful new tool for diagnosing scattering noise.*

Shaking injections made throughout the corner station have shown, in recent PEM injections, as well as for some time before that, that above a few Hz, motion of the vacuum enclosure couples most strongly to DARM in the HAM5/6 area of both LHO and LLO. We have had trouble narrowing down the coupling site further using the shaking amplitude technique because the HAM5/6 region is relatively small and interconnected (if you shake one side of HAM5, the opposite side of HAM6 moves almost as much).

**Impulse injection delays**

To provide extra information, we investigated the use of impulse propagation delays to help identify coupling sites. In the past, we have narrowed down coupling sites by looking for the microphone that detects an acoustic impulse at about the same time that the signal appears in DARM. And, of course, we have tapped on the vacuum enclosure. But we hadn't tried using propagation delays from impacts on the vacuum enclosure to accelerometers mounted on the enclosure. While the vacuum enclosure is made of steel, the propagation velocity of waves on the steel membrane and structure is much lower than the velocity for bulk steel, resulting in tens of millisecond delays for propagation between HAM5 and 6.

Figures 1 and 2 show, for LHO and LLO respectively, examples of impulse injection data. These and other injections indicate that vacuum enclosure impulses show up in DARM about the same time as it shows up on the septum accelerometer.

The down side to the impulse timing technique is that higher frequencies are needed in order to discriminate arrival times (here we have used a 70-200 Hz band). Thus, there is the danger that a coupling site that dominates at low frequencies is not the dominant site at high frequencies. However, we have checked bands at lower frequencies and not seen obvious differences and results from two other impulse-based techniques are consistent.

**Impulse injection amplitudes**

In addition to arrival timing, we also used the amplitude of the prompt impulse vs. the amplitude of the prompt signal in DARM to discriminate coupling locations. The examples in Figures 1 and 2 show that the amplitude in DARM is most consistent with the amplitude of the signal on the septum accelerometer. An advantage of the impulse technique over our usual shaking is that there appears to be a greater difference in amplitude between accelerometers on HAM5 and those on HAM6 for an impulse injection than for a steady state injection. This may be because, for the steady state, the many late reflections have built up the amplitude to nearly the same at all locations in the region (in equilibrium, the energy gets distributed more evenly).

**Impulse injection frequency content**



**Figure 1a. L1 coupling time and amplitude consistent with septum or HAM5 walls, not HAM6 walls or ISI tables**

Soft hammer strike on HAM6 end cap, 70 – 200 Hz band

Soft hammer strike on SRTube by HAM5, 70-200 Hz band

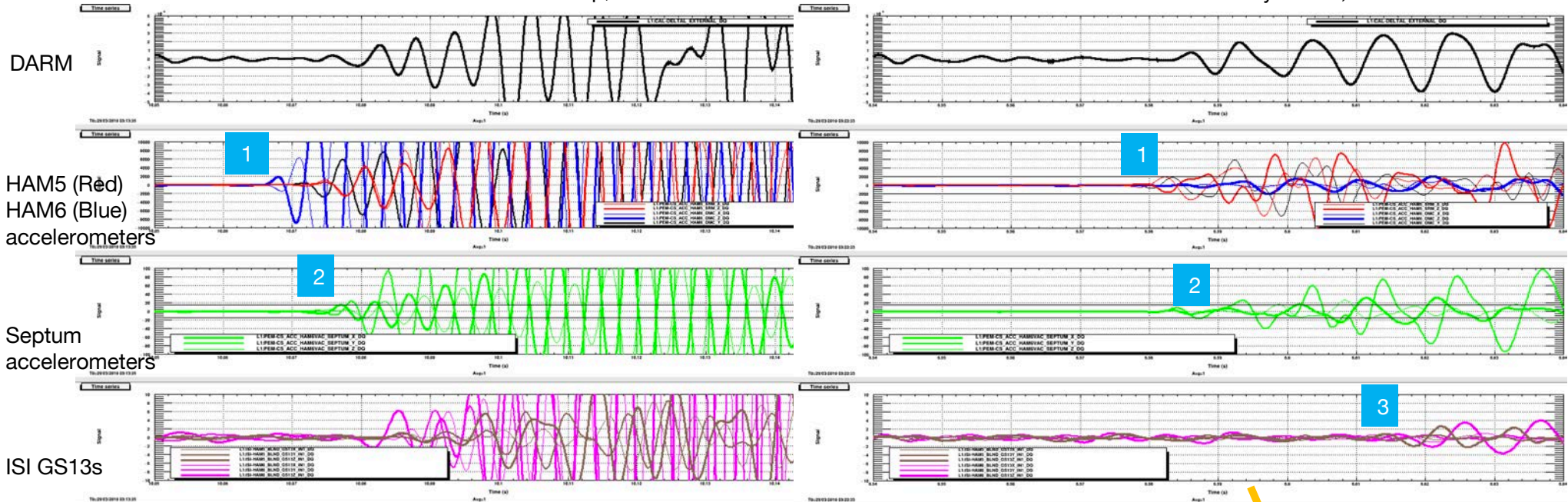

- 1 Blue HAM 6 accelerometers are not consistent in amplitude or time with effect in DARM, while HAM5 and septum accelerometers are.
- 2 For example, DARM (top trace) crosses 1 about the same time as The green septum accelerometers cross 15 for these and other impulses.
- 3 Late arrival of signal on ISI GS13s indicates that the effect in DARM is associated with the vacuum enclosure, not motion of table.

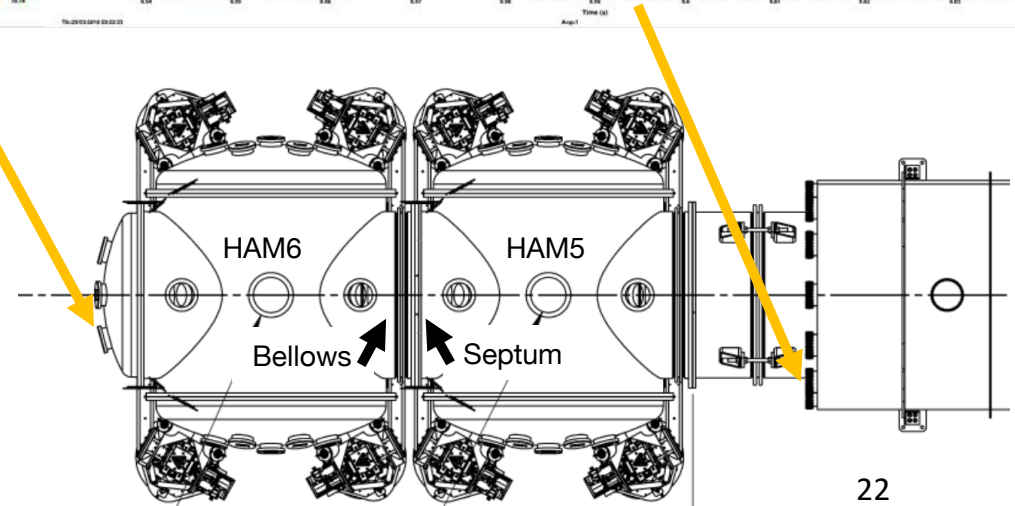

**Figure 1b. L1 coupling amplitude is most consistent with septum, not other monitored parts of HAM5**

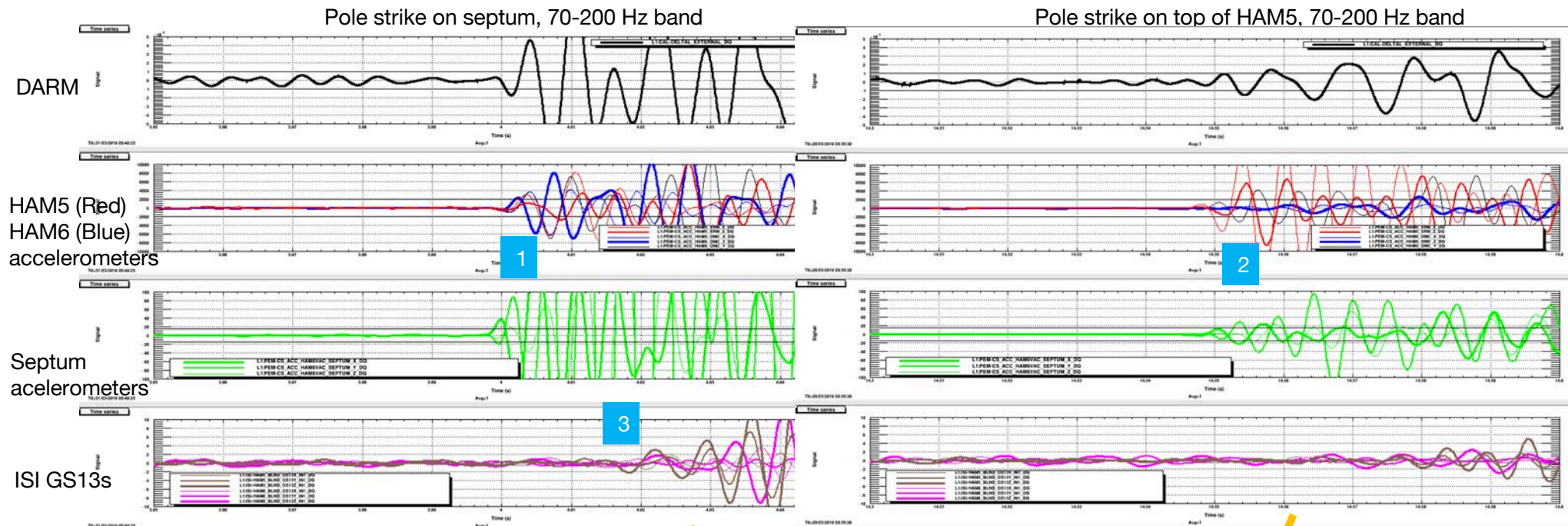

- 1** Green septum accelerometers are consistent with signal size in DARM but red HAM5 accelerometer signals are bigger for the impulse on the right than for the one on the left, while the DARM amplitude is the other way around.
- 2**
- 3** Late arrival of signal on ISI GS13s indicates that the effect in DARM is associated with the vacuum enclosure, not motion of table.

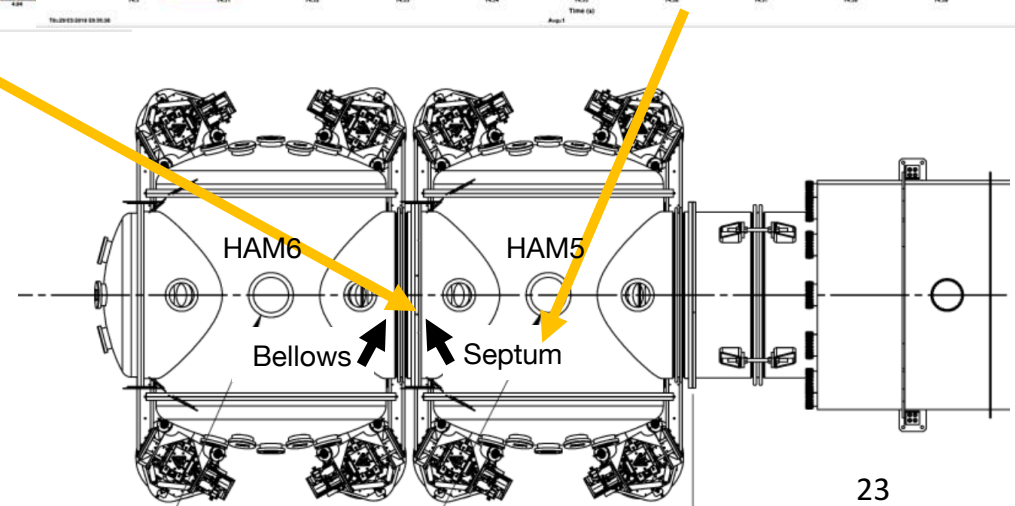

## Figure 2a. H1 coupling time and amplitude consistent with septum, not HAM5/6 walls or ISI tables

Pole strike on HAM6 end cap, 70 – 200 Hz band

Pole strike on HAM5 +Y flange, 70-200 Hz band

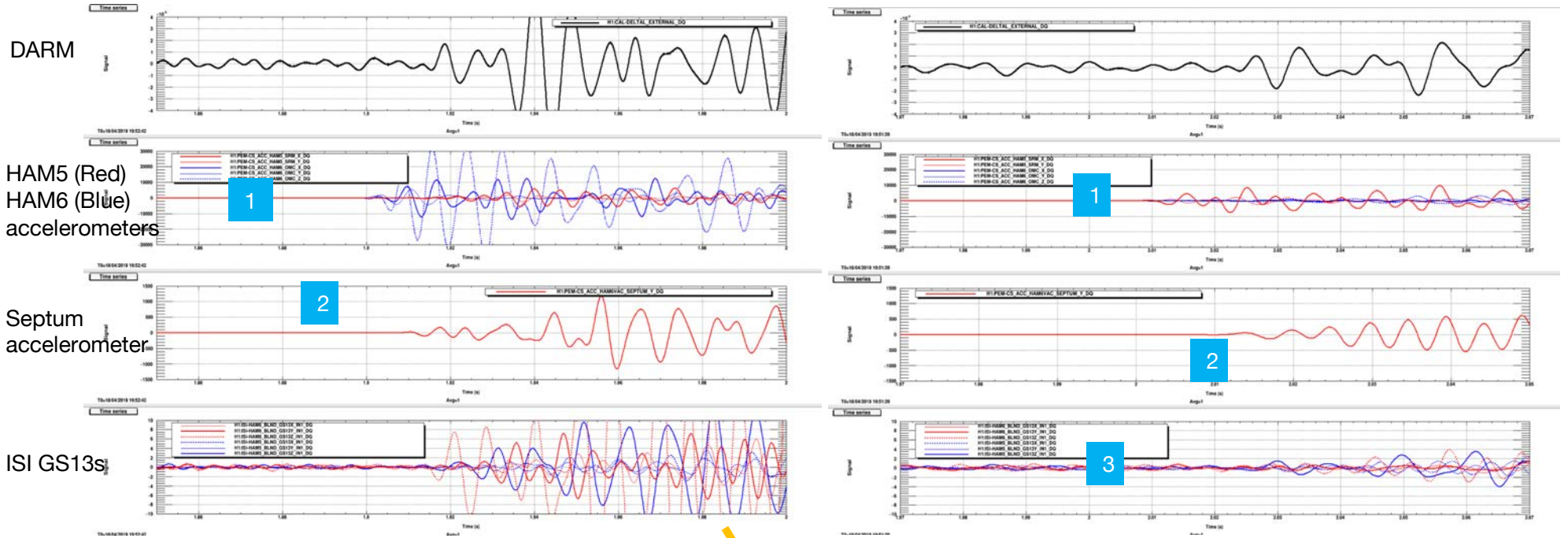

- 1 Blue HAM6 and red HAM5 accelerometers are not consistent in amplitude or time with effect in DARM
- 2 Septum accelerometer is more consistent in time and amplitude with DARM
- 3 Late arrival of signal on ISI GS13s indicates that the effect in DARM is associated with the vacuum enclosure, not motion of table.

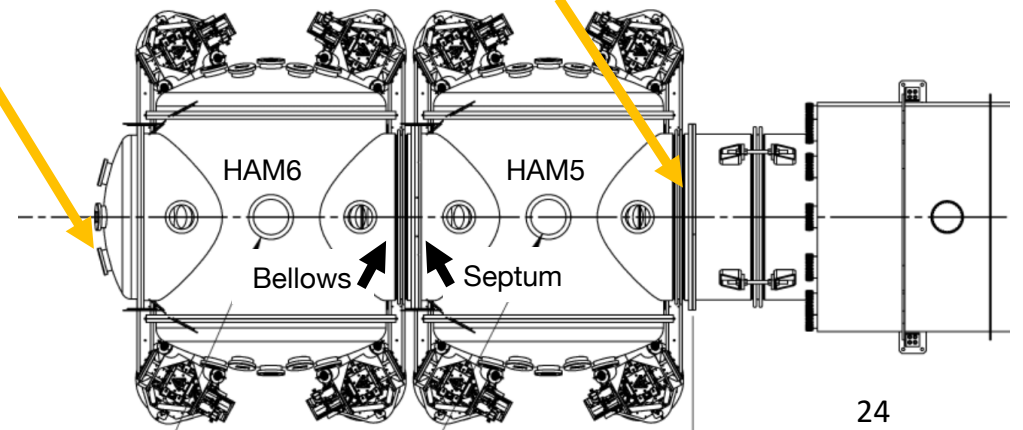

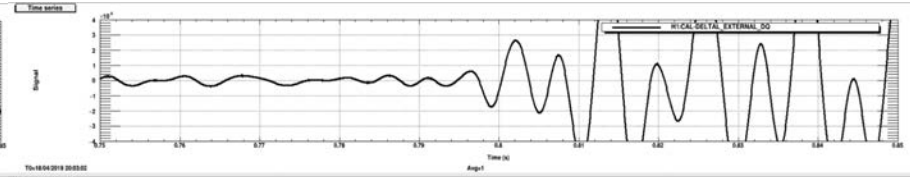
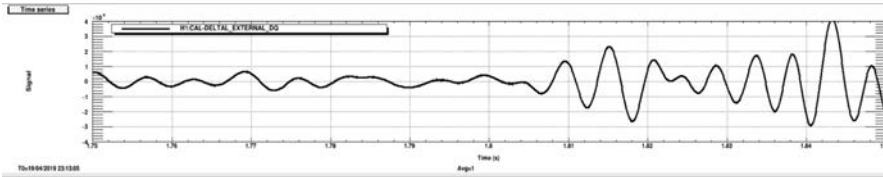

**Figure 2b. H1 coupling time and amplitude consistent with septum, not HAM5/6 walls or ISI tables**

Pole strike on HAM6 -X door, 70 – 200 Hz band

Pole strike on HAM5 -X door, 70-200 Hz band

DARM



HAM5 (Red)  
HAM6 (Blue)  
accelerometers

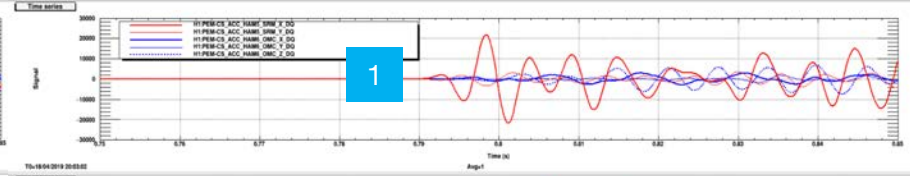
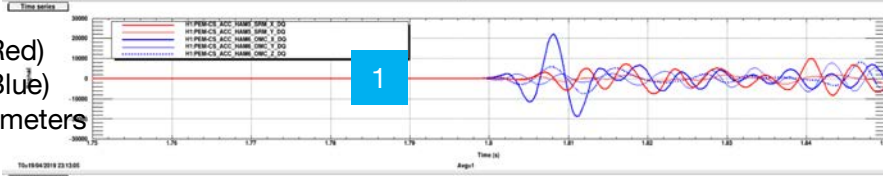

Septum  
accelerometer

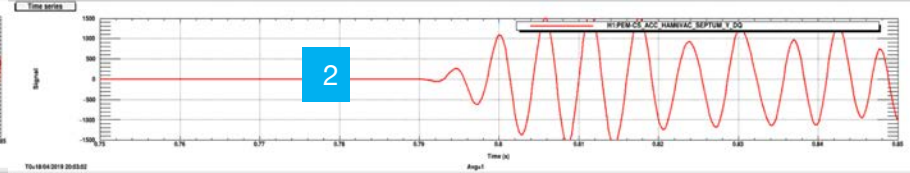
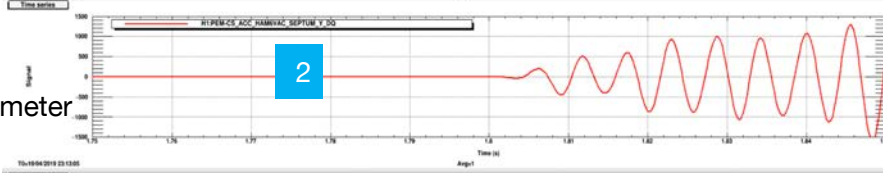

ISI GS13s

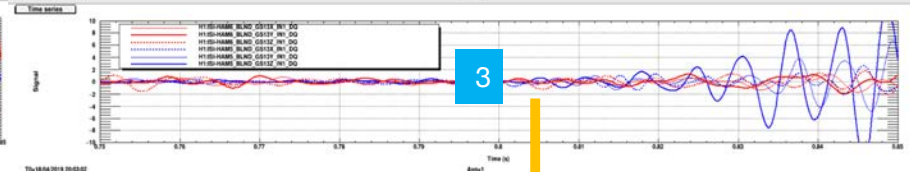
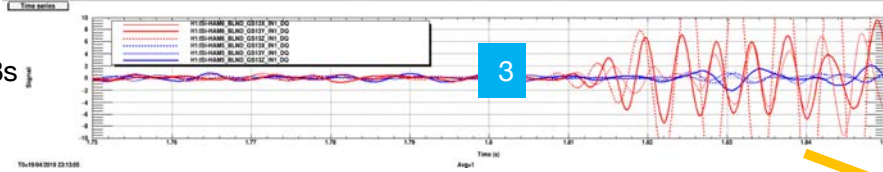

- 1 Blue HAM 6, and red HAM5 accelerometers are not consistent in amplitude or time with effect in DARM.
- 2 Septum accelerometer is more consistent in time and amplitude with DARM
- 3 Late arrival of signal on ISI GS13s indicates that the effect in DARM is associated with the vacuum enclosure, not motion of table.

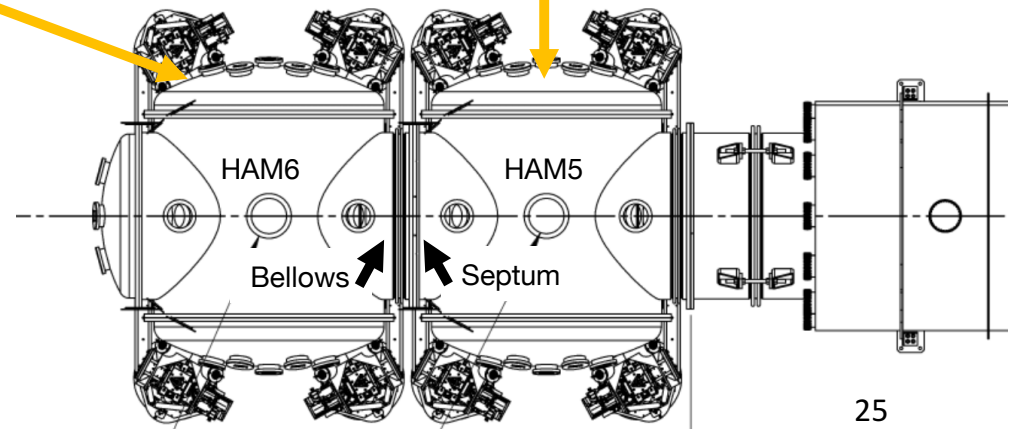

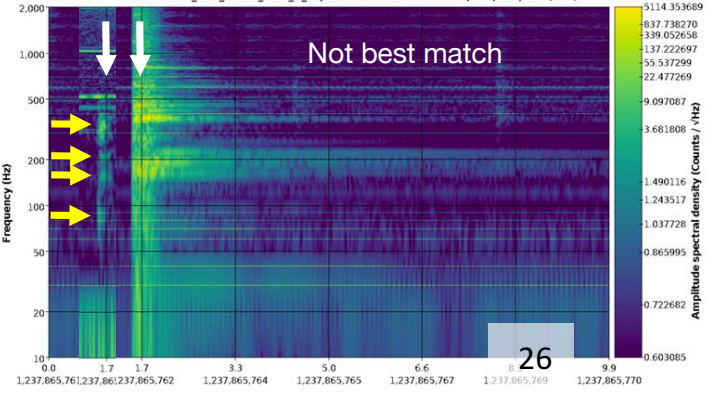
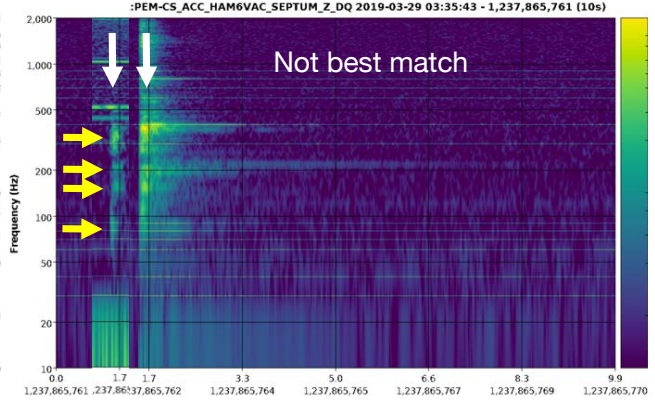
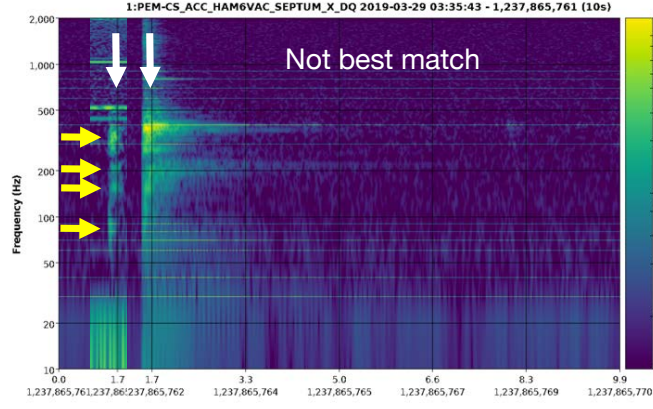
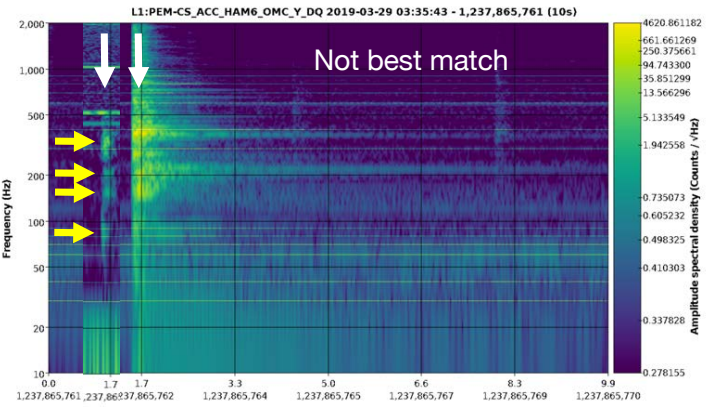
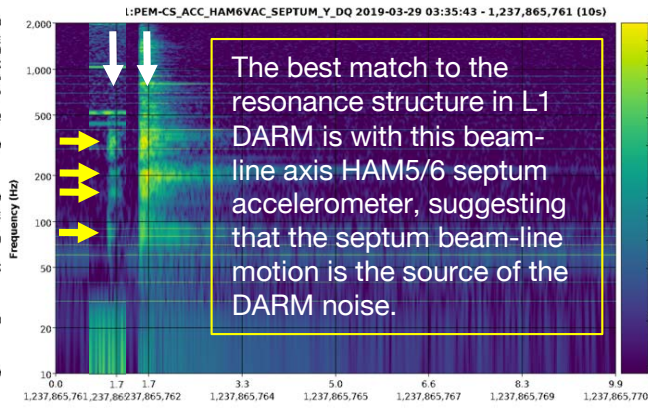
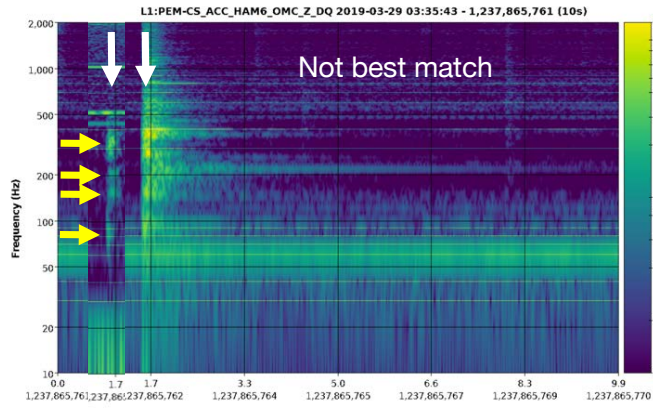
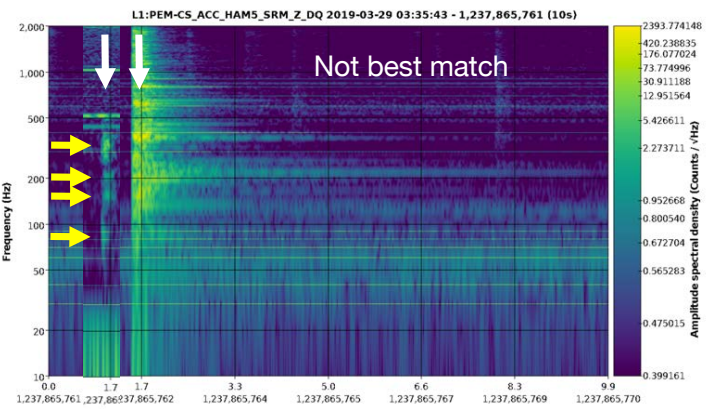
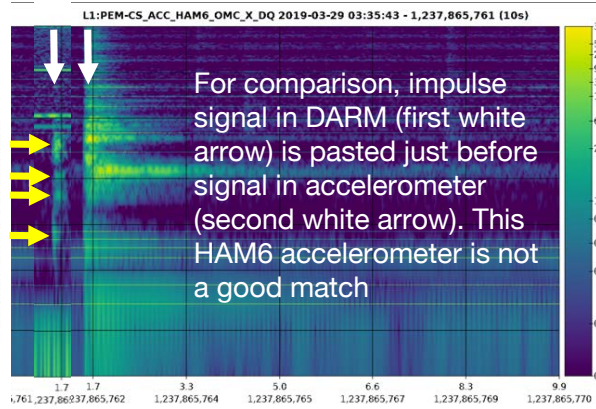
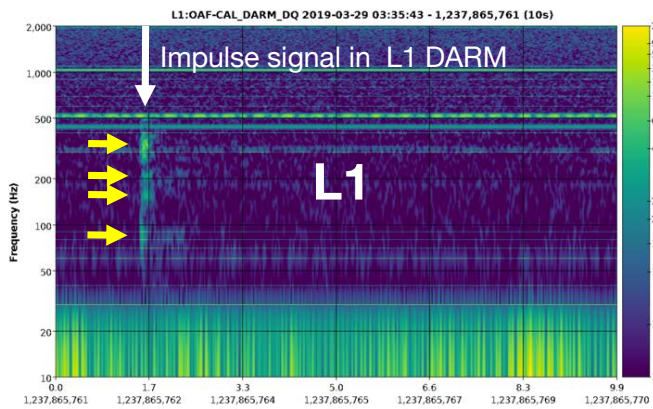

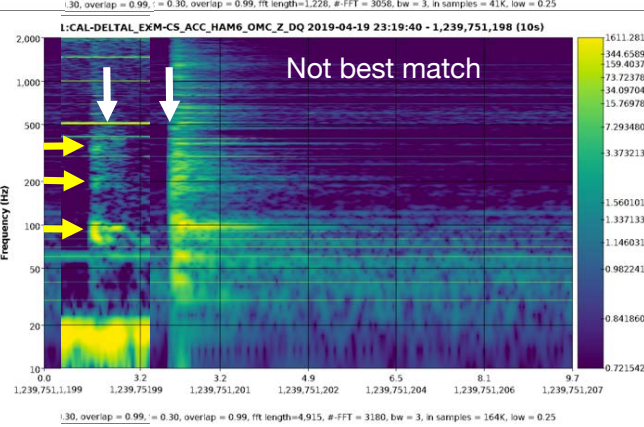
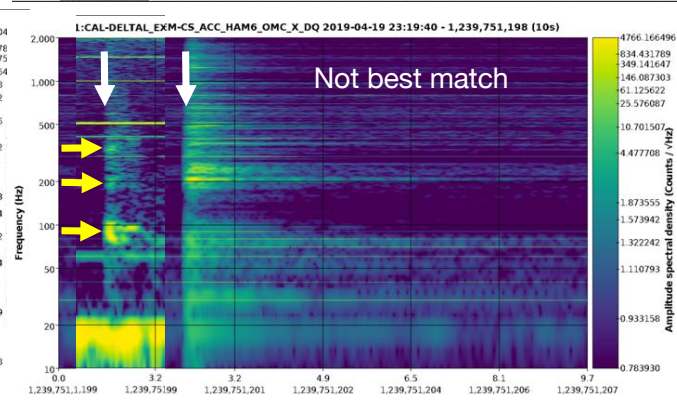
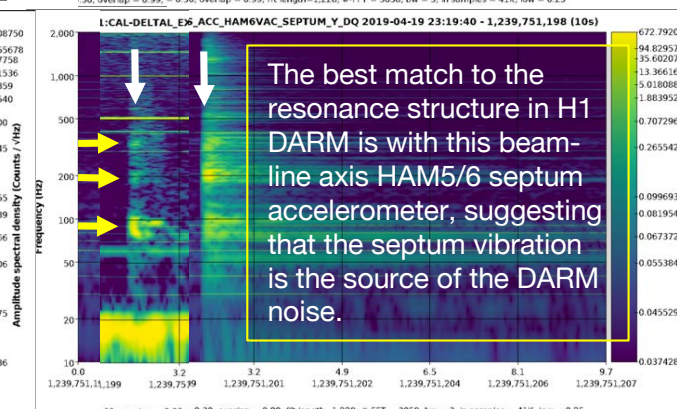
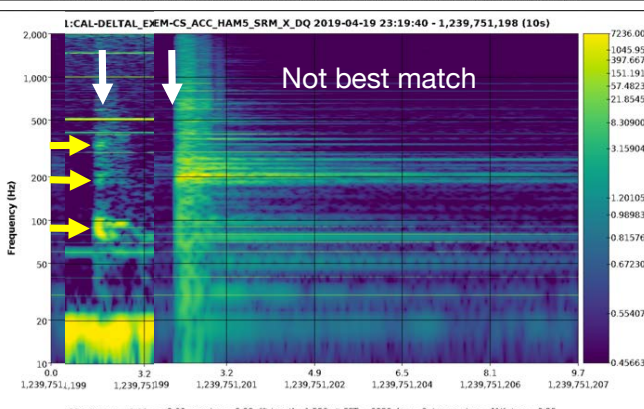
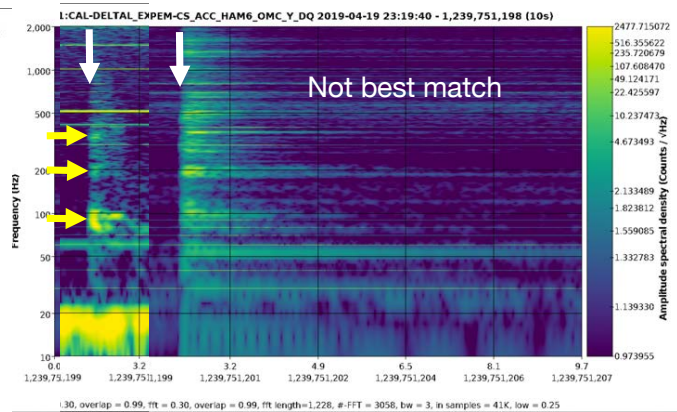
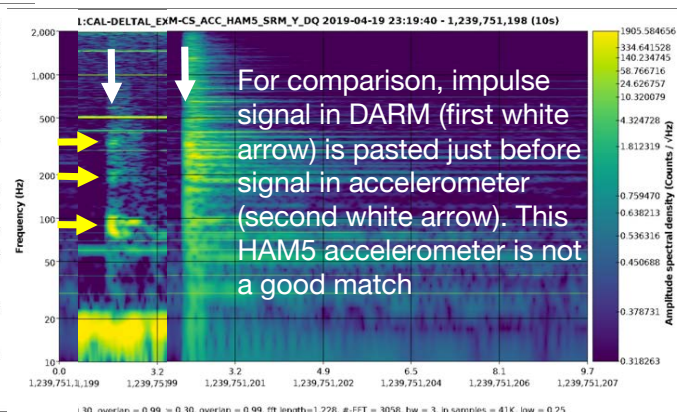
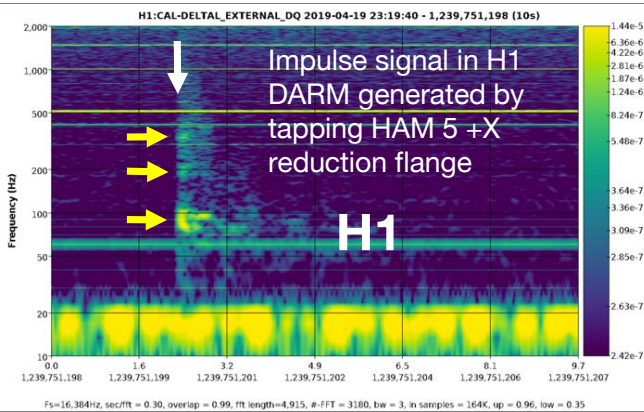

## Introduction

### A. Vibration coupling

- 1) Worst site: LLO EX transmission monitor
- 2) Next worst sites at LLO are EY and HAM5/6 and, at LHO, HAM5/6 and the PSL
- 3) At both sites, HAM5/6 coupling is likely at the septum
- 4) **EY coupling at LLO is likely in the manifold, at LHO, it may be in the ETMY chamber**

- 5) HAM5/6 coupling at the septum window?

*Other beam spots on LLO HAM6*

*OMC REFL beam not the cause of the main HAM5/6 scattering*

*HAM6 witness search at LLO*

- 6) IO jitter coupling at both sites

- 7) Comparison of EY and EX in-lock photos

- 8) Shaker injections at EY produce noise similar to some anthropogenic noise

- 9) Other vibration coupling

*Beamtube shaking*

*Coupling at LHO BS chamber and at the reduction flanges by the optical lever*

*48 Hz peak at LHO*

*Reduction of 58 Hz chiller peak at LHO:*

- 10) Vibration coupling not seen (at least 10 below DARM)

- 11) Coupling estimates from PEM injections correctly predict environmental coupling

*LLO DARM glitch near S190510g is correctly predicted from PEM injection coupling functions.*

*Range reduction from LHO HVAC is roughly predicted from estimates for HAM5/6.*

*Range reduction from rain at LHO is roughly consistent with PEM coupling functions*

*Range reduction from wind at LHO is roughly consistent with PEM coupling functions.*

### B. Magnetic Coupling

### C. RF Coupling

### D. Site activities

## L1 PEM (Detchar)

Link 

robert.schofield@LIGO.ORG - posted 19:55, Saturday 25 May 2019 (46208)

### **Impulse injections suggest that EY vibration coupling is, at LLO, near the Pcal periscope and, at LHO, possibly in BSC10.**

Philippe Nguyen, Sharan Banagiri, Corey Austin, Anamaria Effler, Robert Schofield

*Summary: impulse injections suggest that the vibration coupling site at LLO EY is in the manifold (near the Pcal periscope) and, with less certainty, that the coupling site at LHO EY is in BSC 10. Resonance structure of the signals suggest that accelerometers were not mounted on the coupling sites. We discuss the limited evidence that baffling the rest of the Pcal periscope and installing nozzle baffles will mitigate the coupling at LLO EY.*

The worst environmental coupling sites are, at LLO, associated with the EX transmission monitor (<https://alog.ligo-la.caltech.edu/aLOG/index.php?callRep=46147>) and after that, the HAM5/6 area, and EY. At LHO, HAM5/6, the PSL and EY are the worst vibration coupling sites.

At both LLO and LHO, impulse injections have narrowed the HAM5/6 vibration coupling sites to the septum ( <https://alog.ligo-wa.caltech.edu/aLOG/index.php?callRep=48886> ). The impulse injections were made from multiple locations and, out of the array of accelerometers in the HAM5/6 area, the Y-axis septum accelerometer signal was most consistent with DARM in arrival time and amplitude for impulses from different directions, and in resonance structure.

We also made impulse injections at EY at both sites in order to narrow down the coupling sites.

Figure 1 shows examples of EY impulse injections at LLO suggesting that the timing and especially the amplitude of the signals are consistent with coupling in the manifold but not the BSC chamber.

Figure 2 shows that, for LHO, the case is most consistent with coupling, not at the manifold, but the BSC chamber itself.

Figure 3 shows the spectral structure of impulses at both sites. DARM has a different spectral fingerprint than any of the accelerometers (unlike the case for HAM5/6 injections). Without the matching resonance structure, the confidence level is lower for the EY sites than for the septum site.

A candidate structure in the manifold at LLO EY is, of course, the Pcal periscope. Figure 4 shows beam spot views of the Pcal periscope at the LLO EY location (that has been causing noise in DARM), and at the 2 LHO locations. The LLO EY location has a fairly bright retro-reflection from the inner back surface indicated by yellow arrows. The "glint" is ranked about as high as the reduction flanges near the ITM

**Figure 1a. LLO EY: accelerometer signals are consistent with manifold coupling but not coupling at the BSC**

Soft hammer strike on GV 10, 70-200 Hz band

Soft hammer strike on underside of BSC5, 70-200 Hz band

DARM

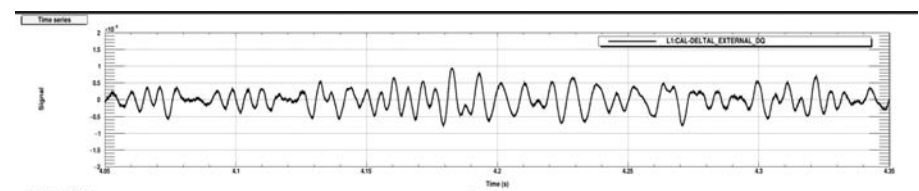
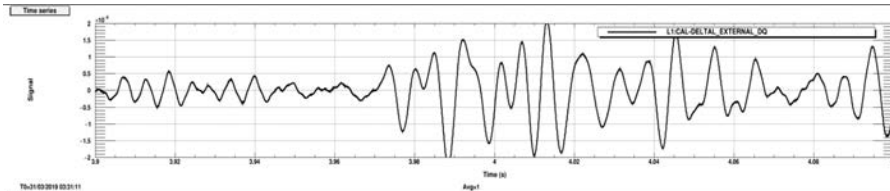

Red and Blue:  
manifold  
accelerometers

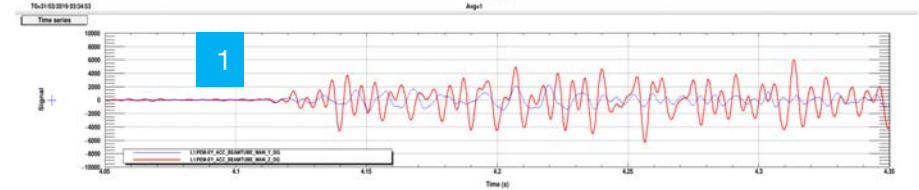
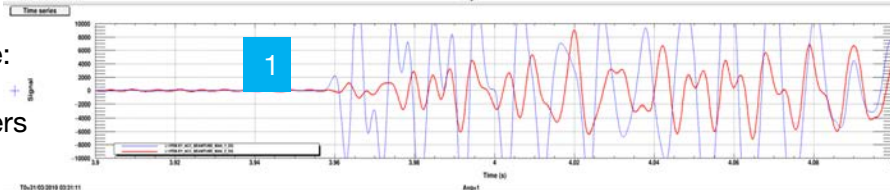

BSC 5  
accelerometers

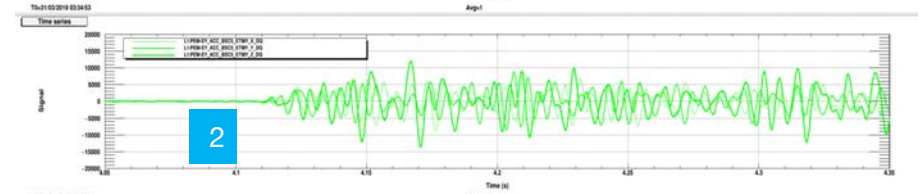
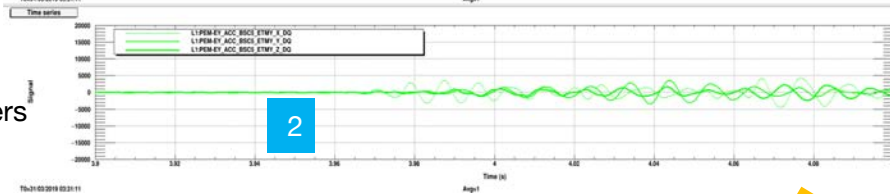

- 1** DARM time and amplitude are consistent with red and blue manifold accelerometers: DARM crosses 1 about the same time red or blue cross 8000 for these and other impulses
- 2** Green BSC chamber accelerometers are not consistent in time or amplitude with DARM signal

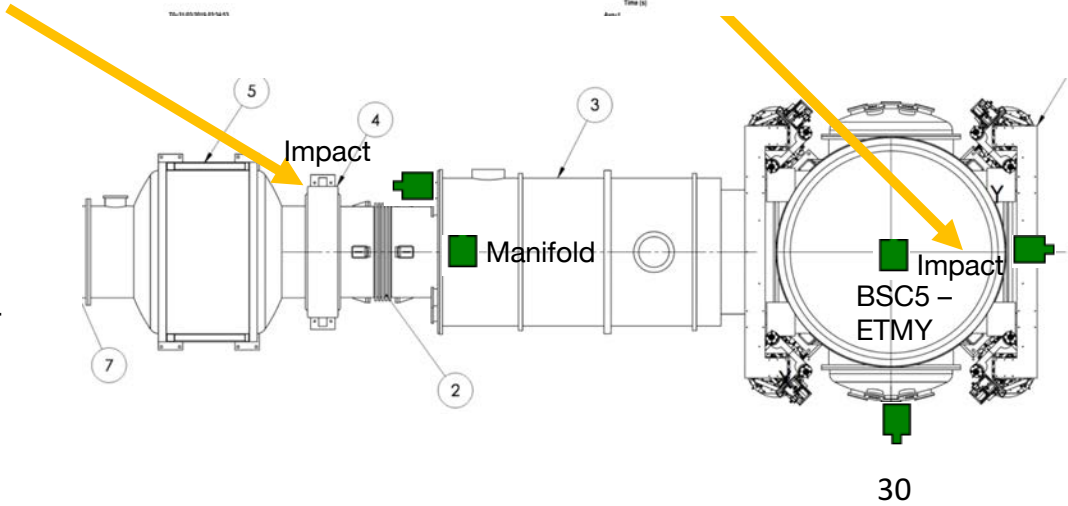
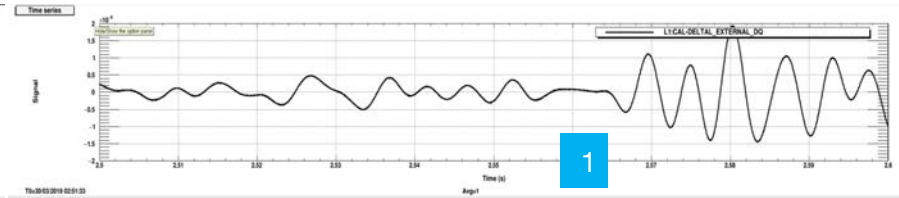
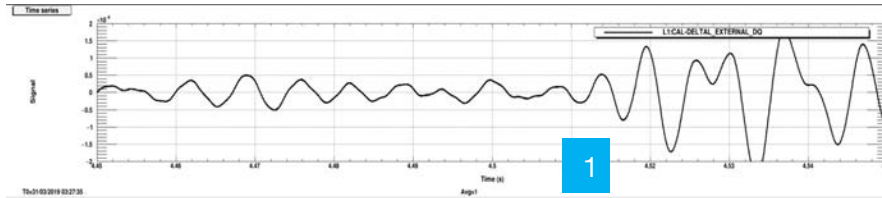

**Figure 1b. LLO EY: accelerometer signals are most consistent with coupling site in manifold**

Soft hammer strike on -Y reduction flange, 70-200 Hz band

Soft hammer strike on end cap, 70-200 Hz band

DARM



Red and Blue:  
manifold  
accelerometers

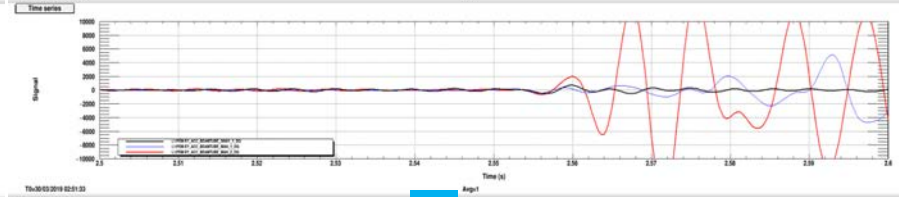
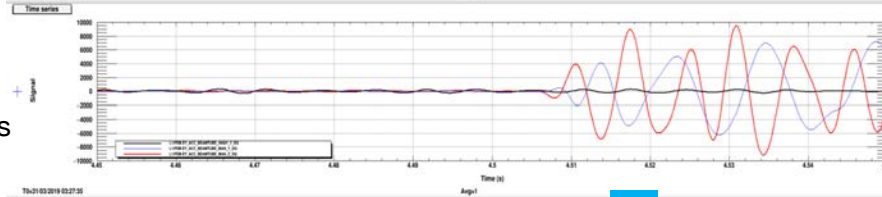

BSC 5  
accelerometers

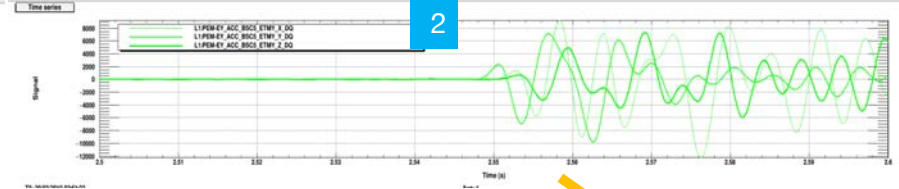
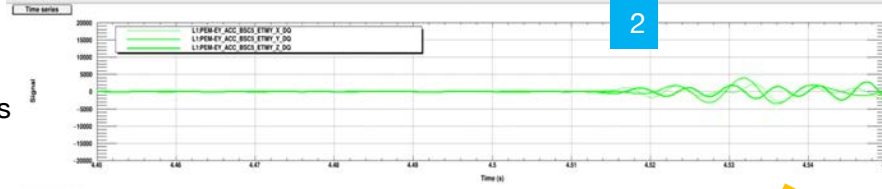

- 1** DARM time and amplitude are consistent with red and blue manifold accelerometers: DARM crosses 1 about the same time red or blue cross 8000 for these and other impulses
- 2** Green BSC chamber accelerometers are not consistent in time or amplitude with DARM signal

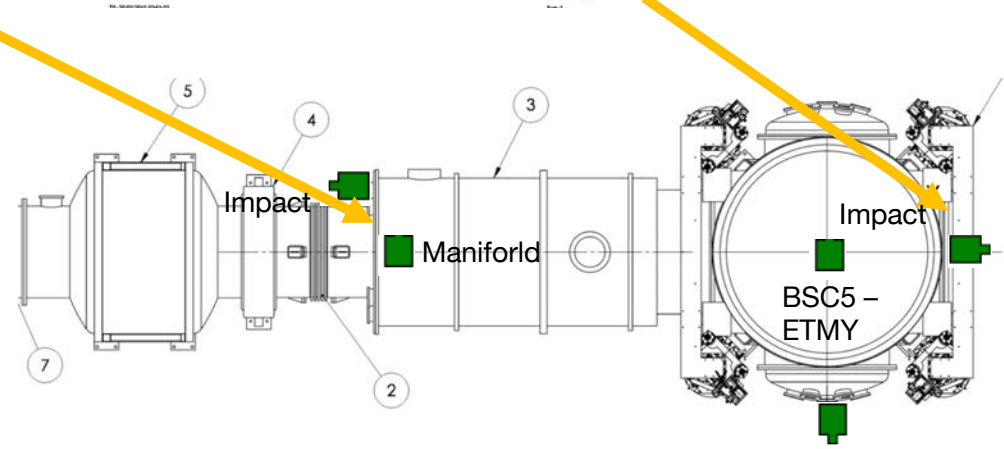

**Figure 2a. LHO EY: accelerometer signals are consistent with BSC coupling but not coupling at the manifold**

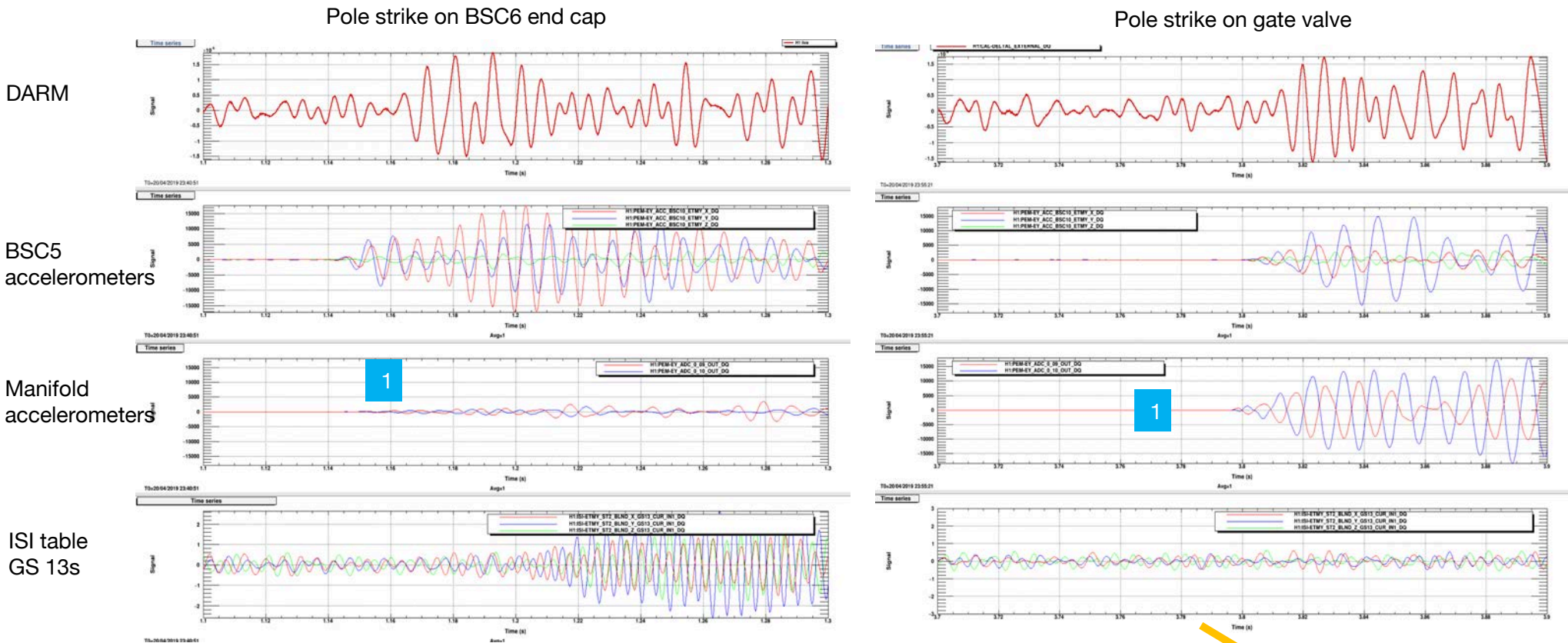

**1** The amplitude of the manifold accelerometers are not consistent with the amplitude in DARM

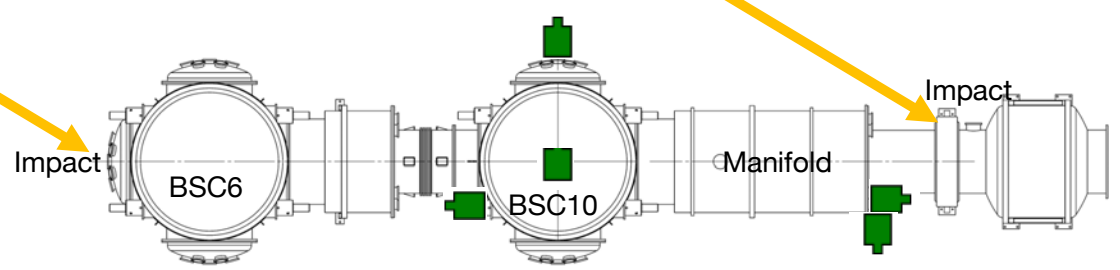
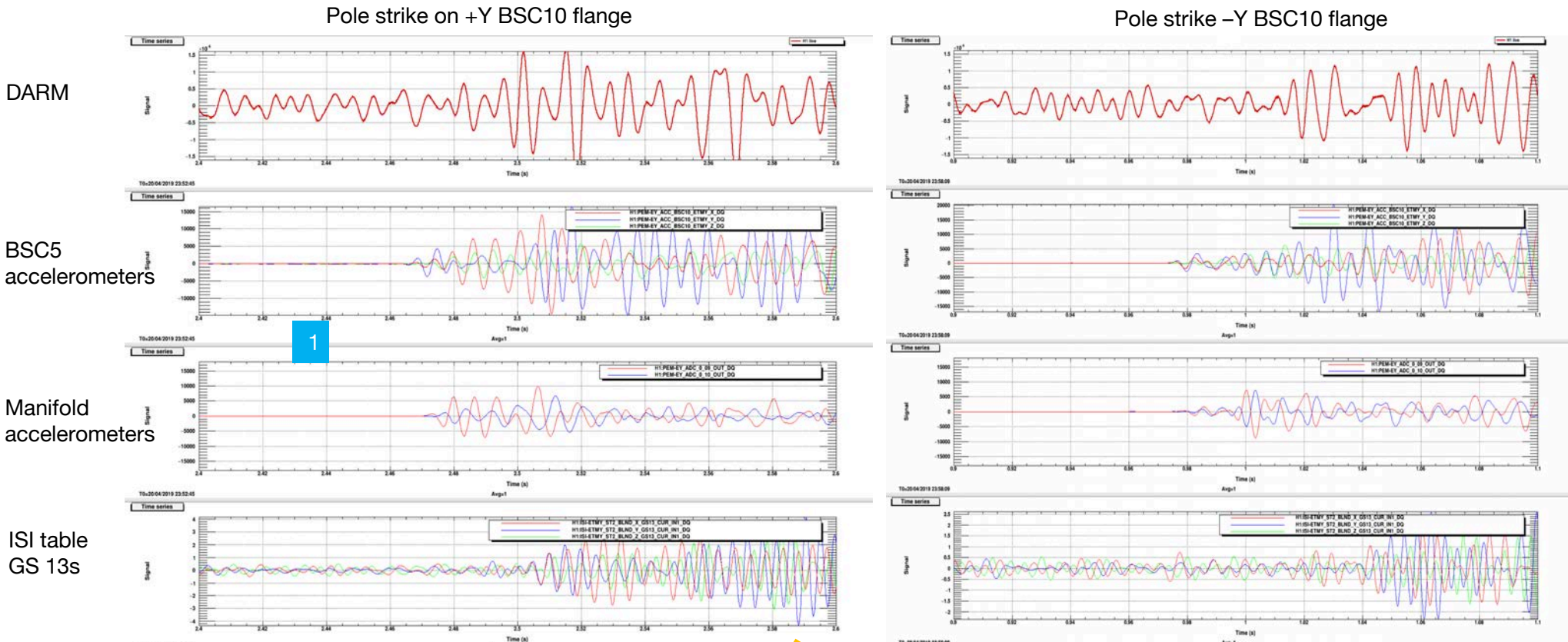



Figure 2b. LHO EY: accelerometer signals are consistent with BSC coupling



DARM

BSC5 accelerometers

Manifold accelerometers

ISI table GS 13s

1

BSC5 accelerometers are slightly more consistent with DARM than manifold accelerometers

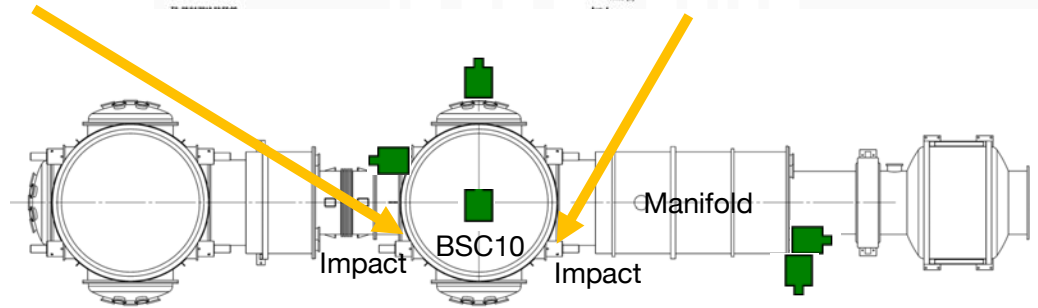

# LLO EY Impulse originating at GV10

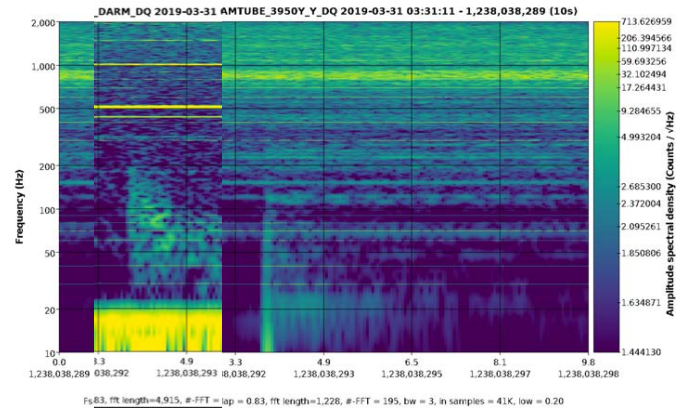
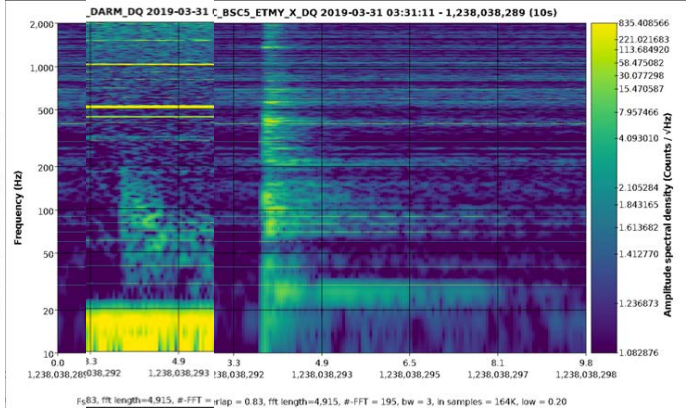
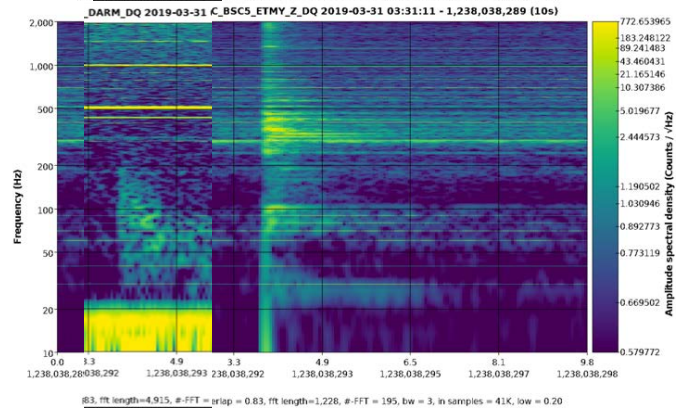
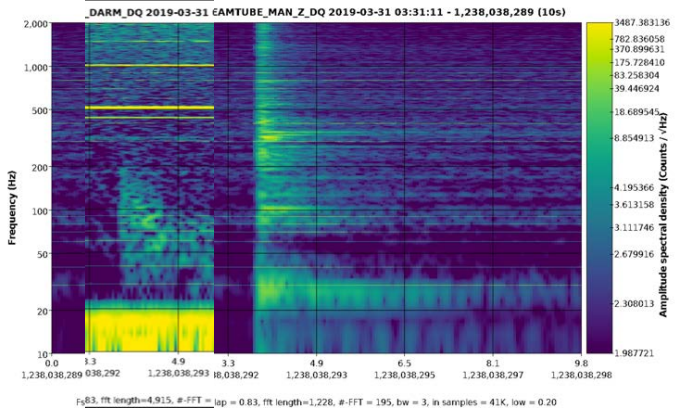
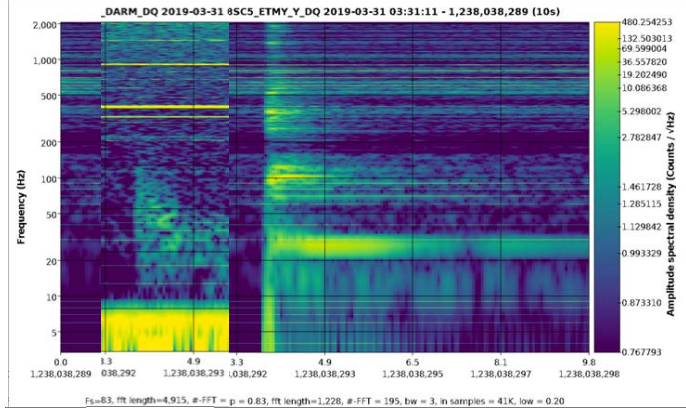
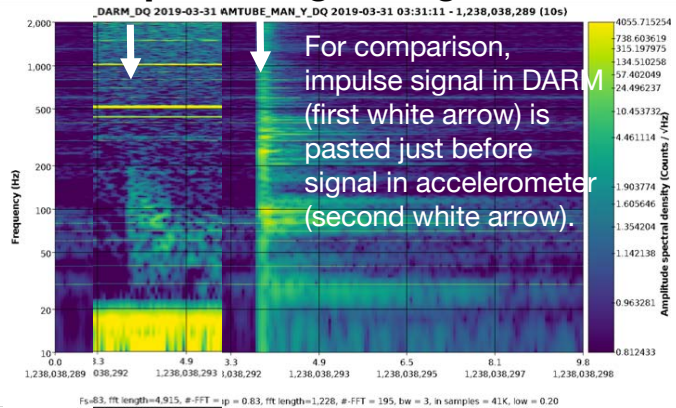
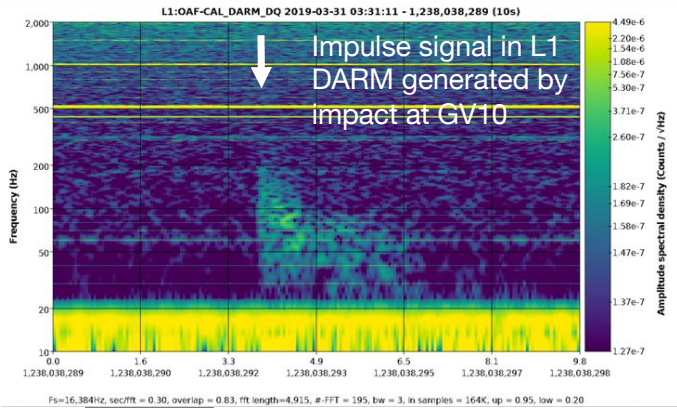

Lack of a match to DARM in frequency content suggests that no accelerometer is on coupling surface.

# LHO EY Impulse originating at GV 18

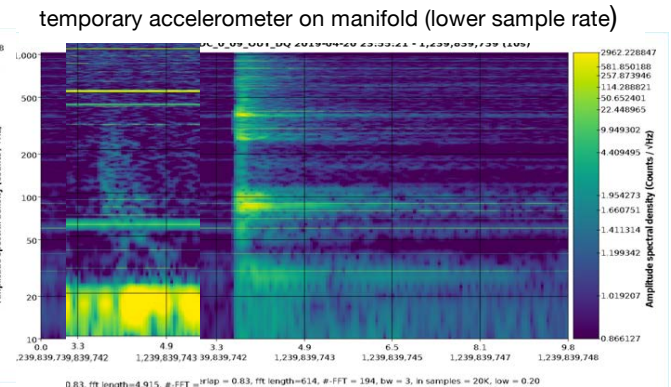
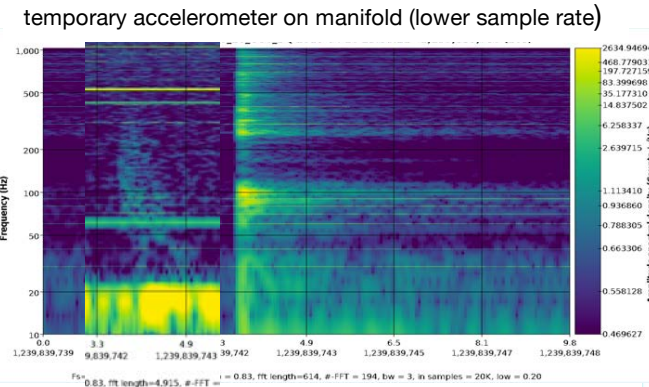
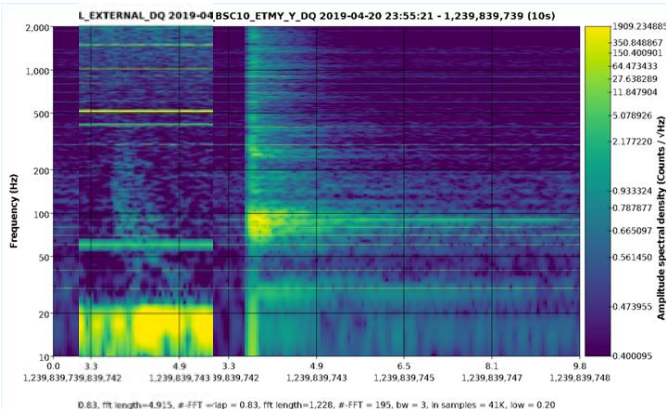
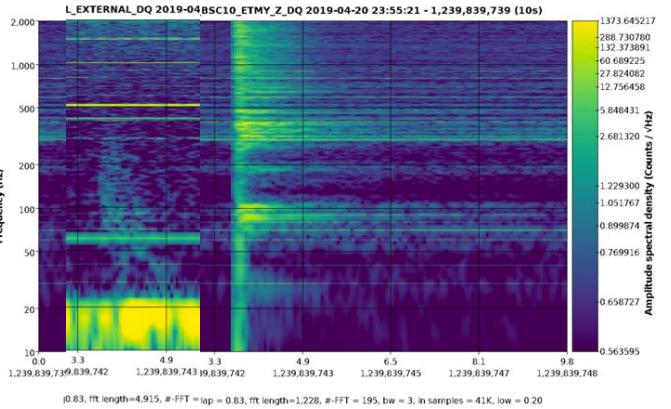
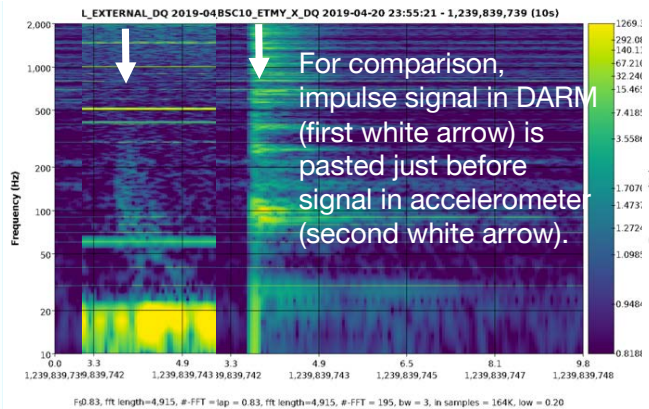
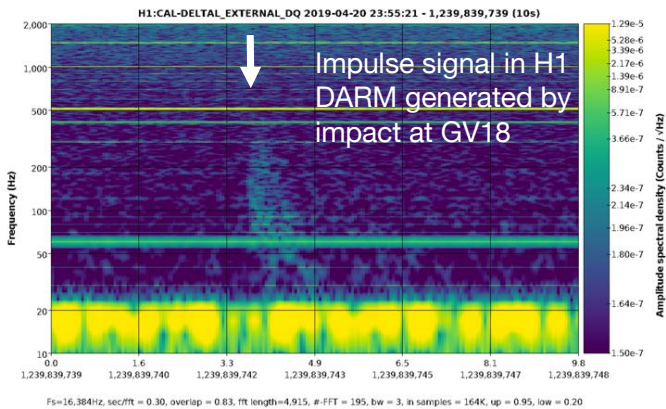

Lack of a match to DARM in frequency content suggests that no accelerometer is on coupling surface. Signal in DARM is slow at starting up, as if not tightly coupled to the vacuum enclosure wall.

## LLO EY (2 views)

Fairly bright retroreflections from back ring of periscope at LLO-EY (yellow arrows)

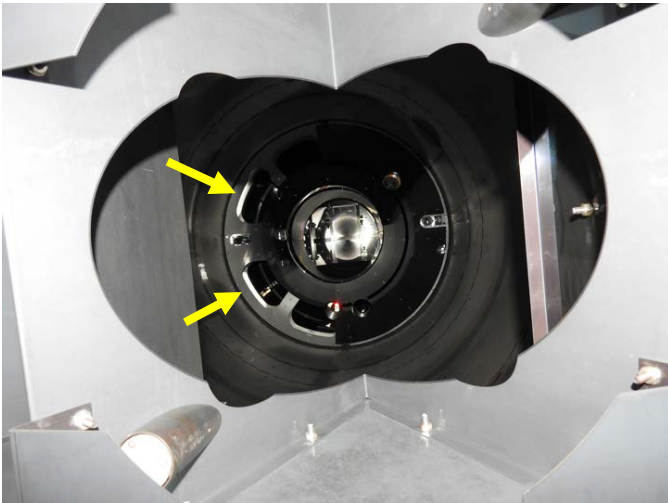

## LHO EY (2 views)

Similar glints can be seen at LHO EY

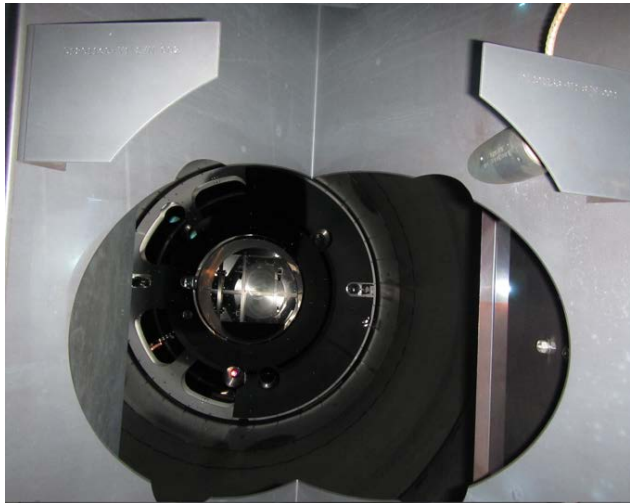

## LHO EX (2 views)

LHO EX has similar glints, without the coupling to DARM.

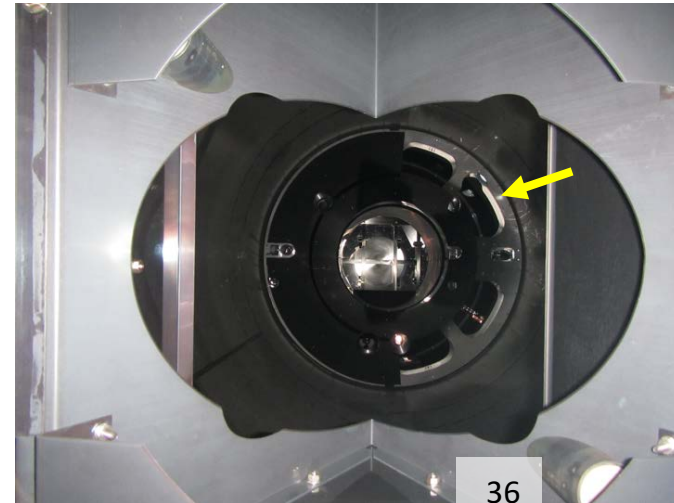

## Introduction

### A. Vibration coupling

- 1) Worst site: LLO EX transmission monitor
- 2) Next worst sites at LLO are EY and HAM5/6 and, at LHO, HAM5/6 and the PSL
- 3) At both sites, HAM5/6 coupling is likely at the septum
- 4) EY coupling at LLO is likely in the manifold, at LHO, it may in the ETMY chamber
- 5) **HAM5/6 coupling at the septum window?**

*Other beam spots on LLO HAM6*

*OMC REFL beam not the cause of the main HAM5/6 scattering*

*HAM6 witness search at LLO*

- 6) IO jitter coupling at both sites
- 7) Comparison of EY and EX in-lock photos
- 8) Shaker injections at EY produce noise similar to some anthropogenic noise
- 9) Other vibration coupling

*Beamtube shaking*

*Coupling at LHO BS chamber and at the reduction flanges by the optical lever*

*48 Hz peak at LHO*

*Reduction of 58 Hz chiller peak at LHO:*

- 10) Vibration coupling not seen (at least 10 below DARM)
- 11) **Coupling estimates from PEM injections correctly predict environmental coupling**
  - LLO DARM glitch near S190510g is correctly predicted from PEM injection coupling functions.*
  - Range reduction from LHO HVAC is roughly predicted from estimates for HAM5/6.*
  - Range reduction from rain at LHO is roughly consistent with PEM coupling functions*
  - Range reduction from wind at LHO is roughly consistent with PEM coupling functions.*

### B. Magnetic Coupling

### C. RF Coupling

### D. Site activities

robert.schofield@LIGO.ORG - posted 15:33, Friday 03 May 2019 (48965)

**The brightest beam spot seen in inspection through HAM5/6 viewports appears to be ~3 degree scattering from the septum window.**

Philippe, Sharon, Anamaria, Robert





We looked for stray light through the 5 viewports indicated on the first page of Figure 1. We saw stray light from the OFI, but, by far, the brightest light appeared to be from the septum window from the end-cap view. I could not see this bright spot from the viewports on HAM5 or the center viewport on the HAM6 endcap, only from the +X viewport on the HAM6 end cap. This view is not available at LLO. Figure 1a-c show photos, and detail the argument that the spot is forward-scattering, at 3-degrees, of light from the beam spot on the septum window. For example, the parallax photographs in Figure 1c are consistent with the origin being at the septum window. In addition, they show that the spot is bright over several inches at the viewport, and thus more likely to be diffuse scattering than a ghost beam.

We could not see all parts of the septum, but, except for the window, we did not see other spots on the septum (this was also the case for the parts of the septum we could see at LLO - <https://alog.ligo-la.caltech.edu/aLOG/index.php?callRep=44985>).

Impulse injections, along with shaker injections, suggest that the septum is the dominant scattering site, at least in the band above 20 Hz, at LHO and LLO: <https://alog.ligo-wa.caltech.edu/aLOG/index.php?callRep=48886>. The noise produced by septum motion, estimated from PEM injection results, is consistent with the loss of range due the HVAC at LHO: <https://alog.ligo-wa.caltech.edu/aLOG/index.php?callRep=48912>. The observation of bright scattering from the LHO window, but not from other examined regions of the septum at either site, is evidence that the septum window could be the scattering site on the septum.

Figure 2 shows a plot from LIGO-T0900269-v2 that is a reminder that we expect scattering from the septum window to be close to limiting. This, along with the visual observation evidence and the evidence from the shaker and impulse injections, all accumulate to suggest that it may be time to consider removing the septum windows at both sites.

**Non-image files attached to this report**

-  [Figure1a-Viewports-septum-window-spot.pdf](#)
-  [Figure1b-Septum-window-spot-OM2pdf.pdf](#)
-  [Figure1c-Septum-window-parallax-partial.pdf](#)
-  [Figure2-Original-estimated-contribution.pdf](#)

Yellow arrows indicate examined views

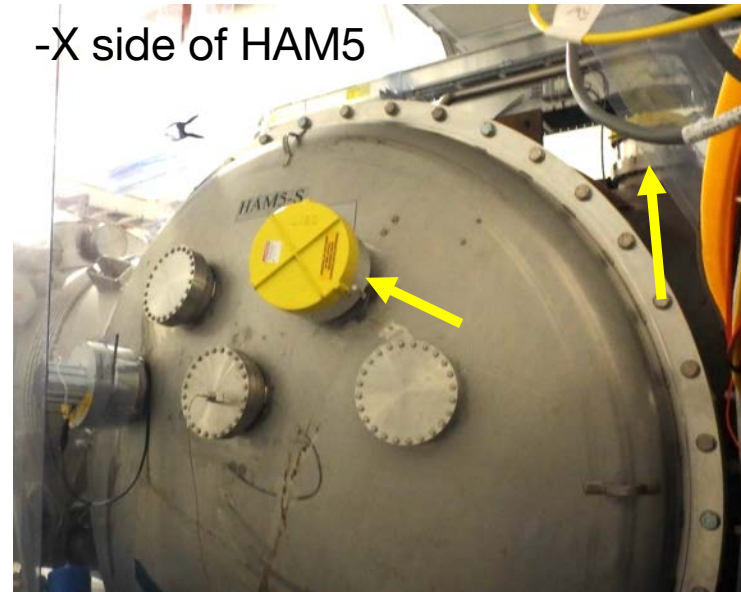
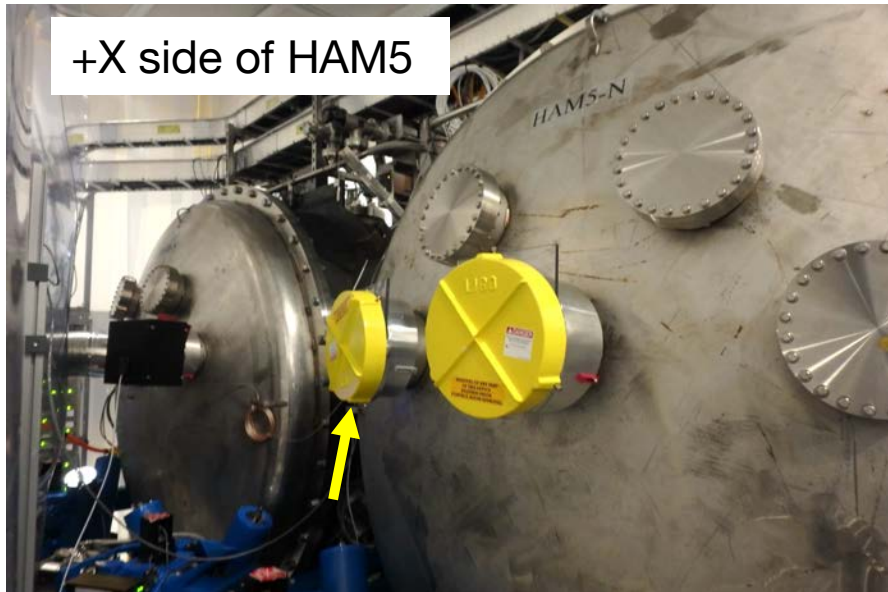
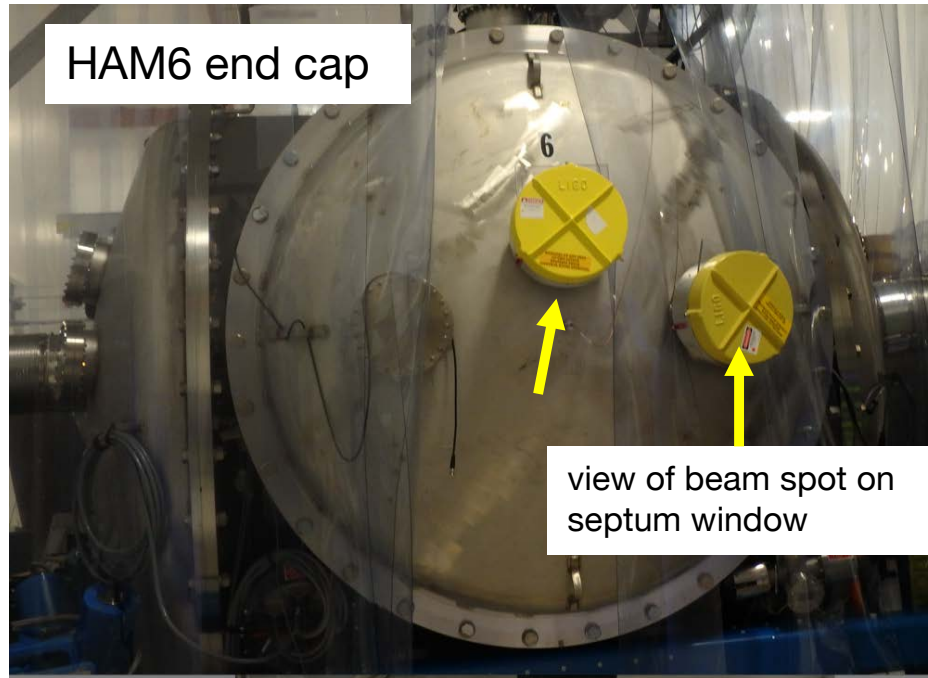

**View from HAM6 endcap viewport indicated on previous page  
toward septum window**

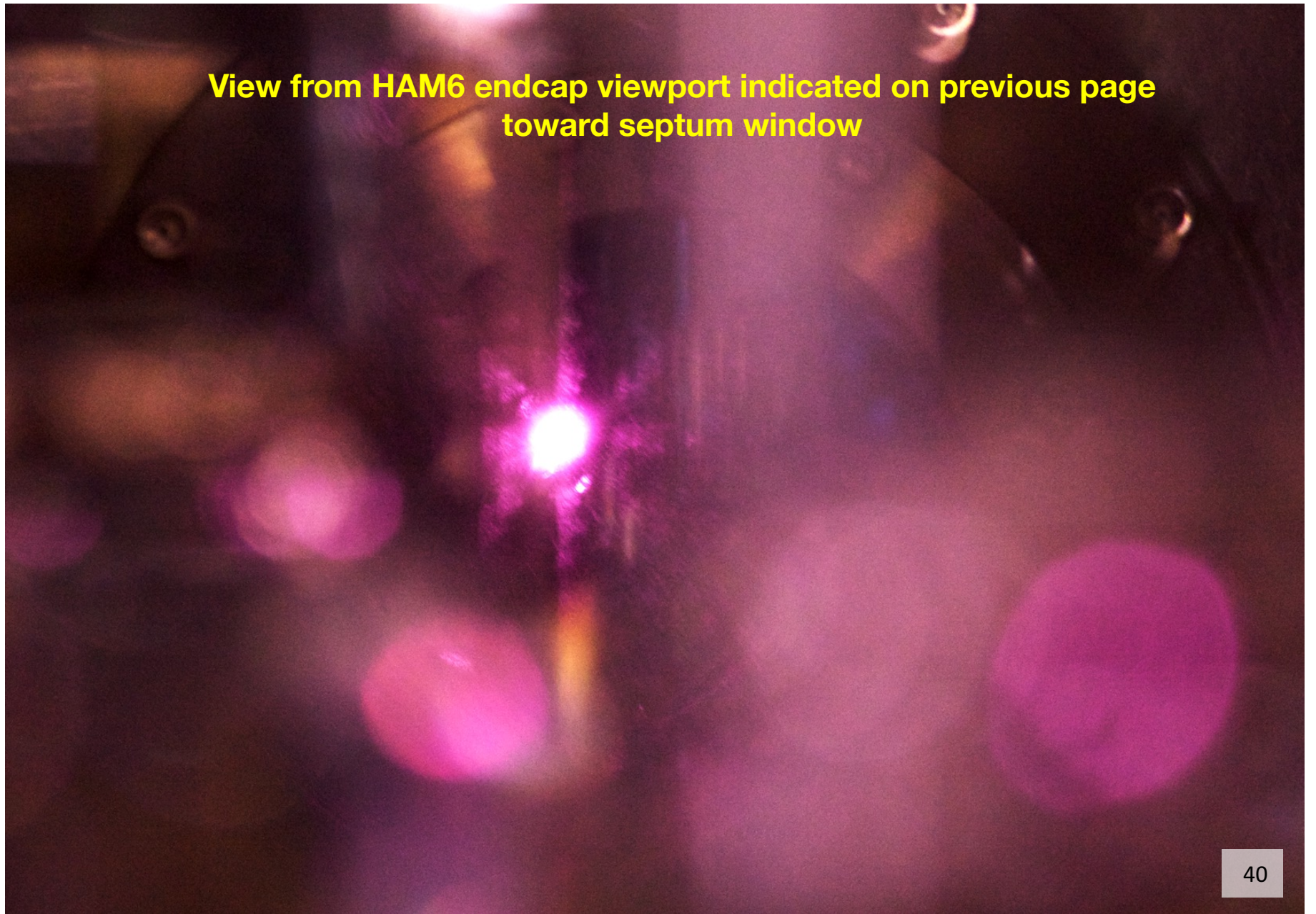



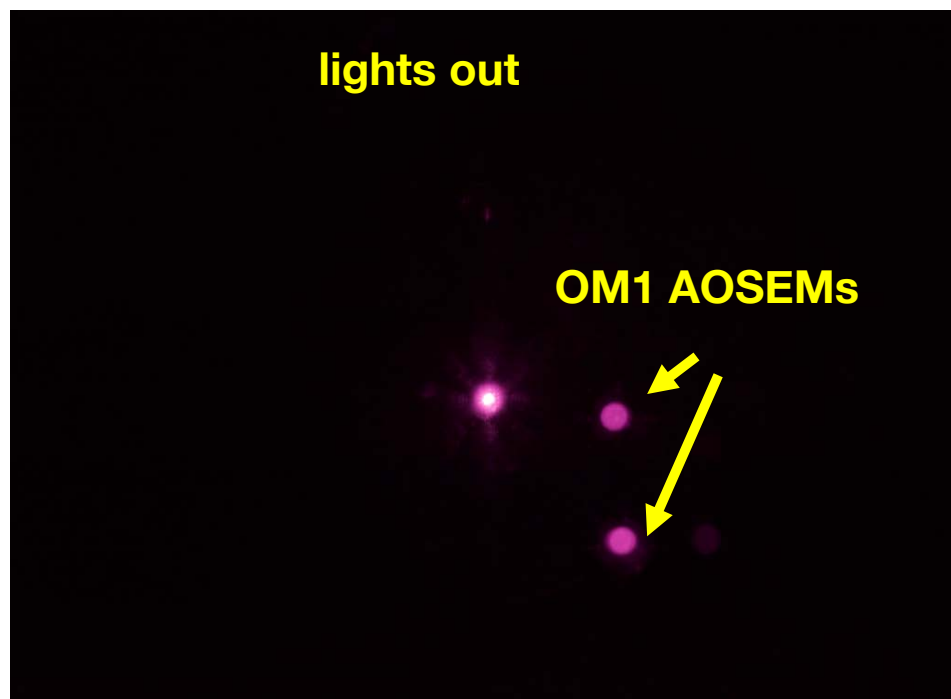
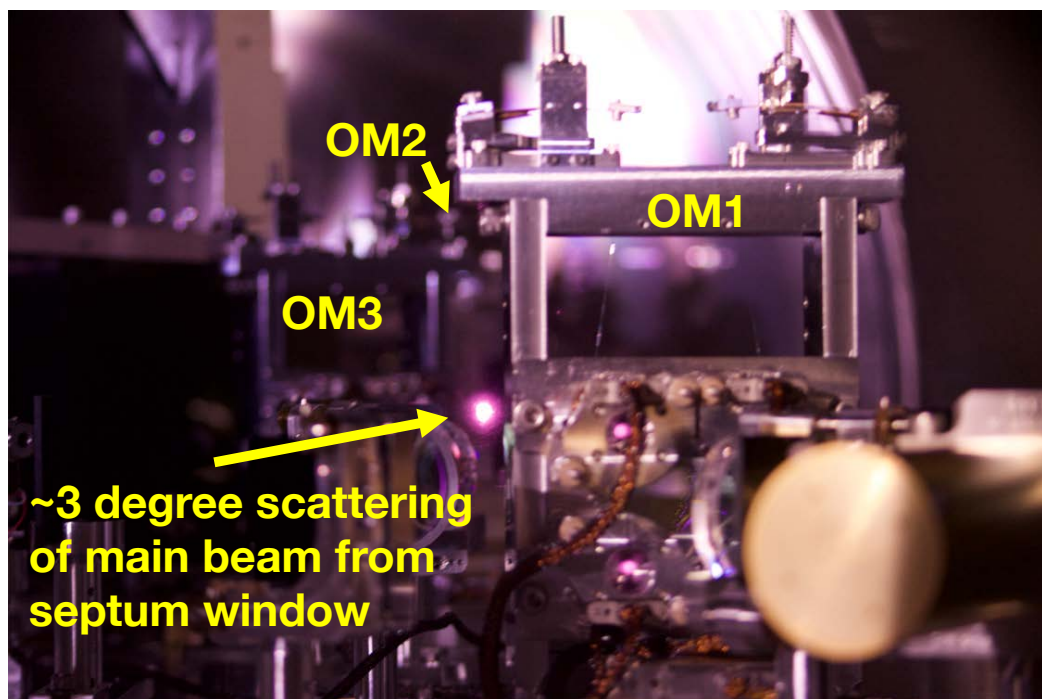

Scattering angle: ~3 degrees

septum window  
(approximate)

OM2

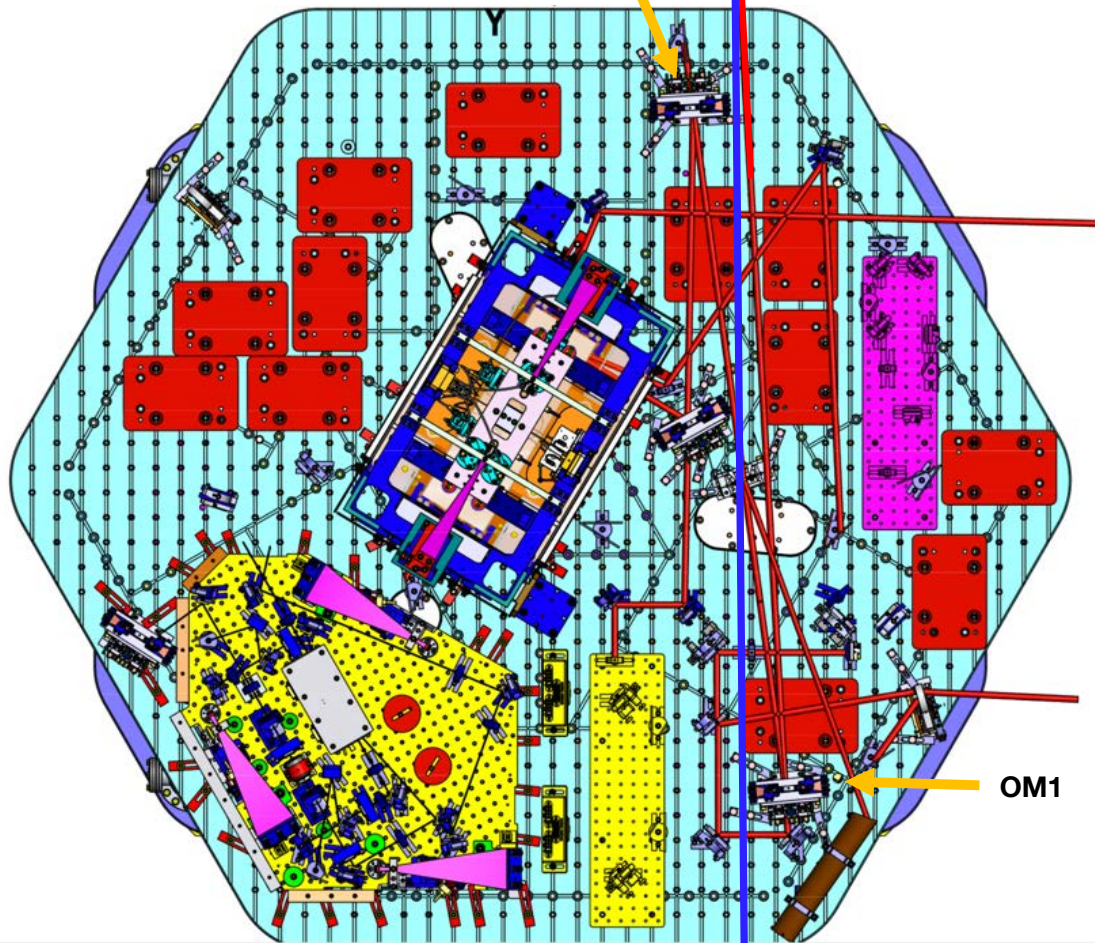

OM1



camera view

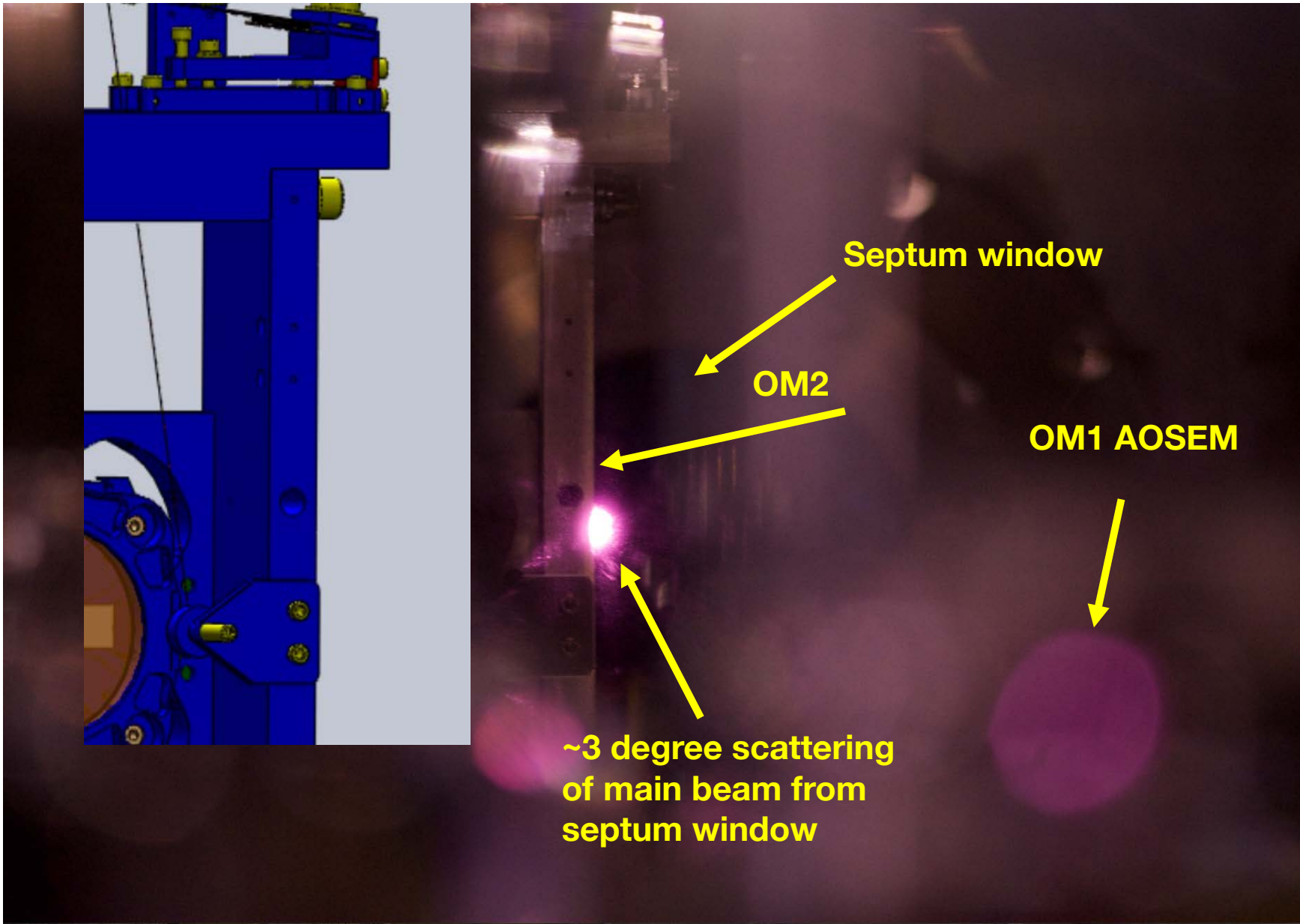



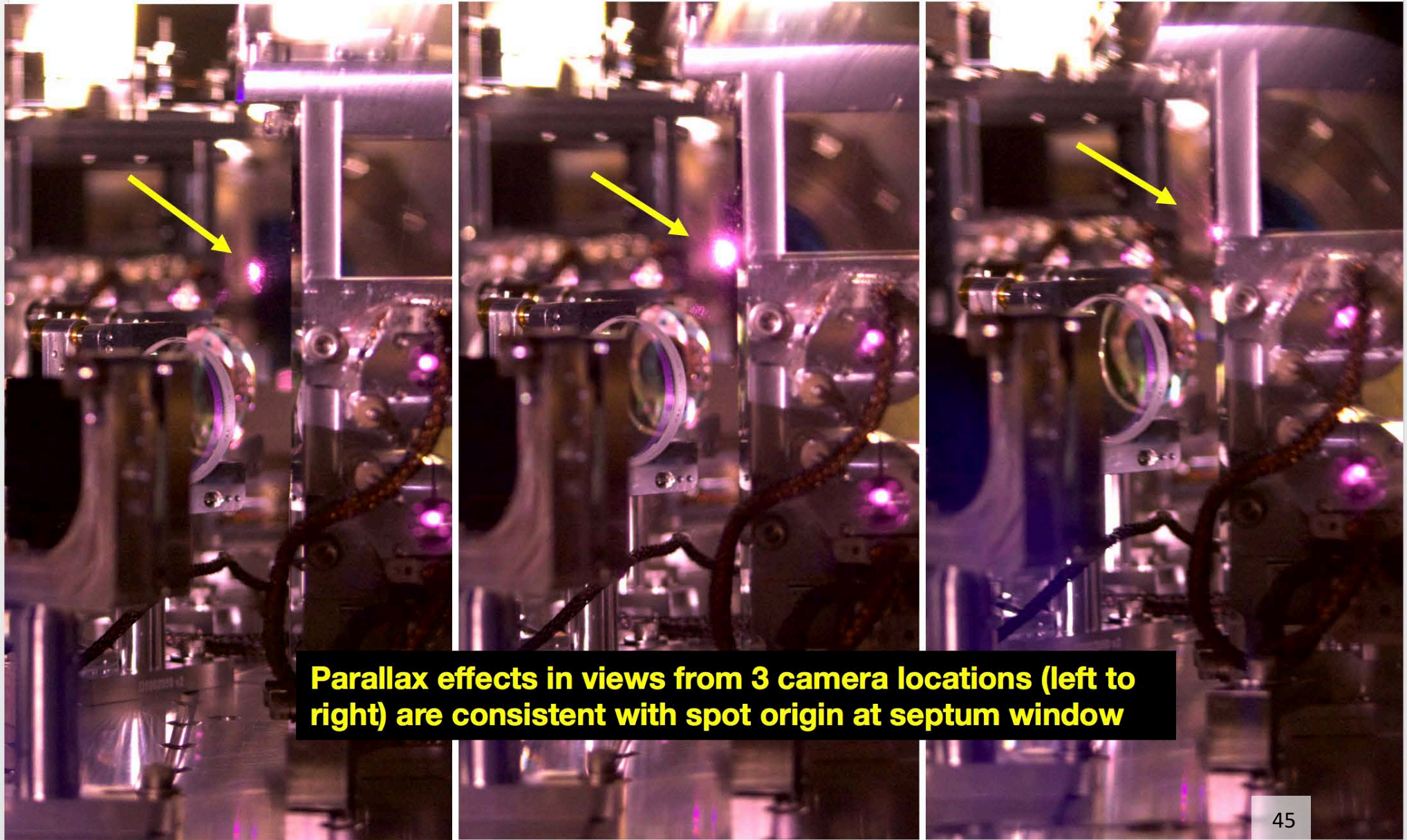

**Parallax effects in views from 3 camera locations (left to right) are consistent with spot origin at septum window**

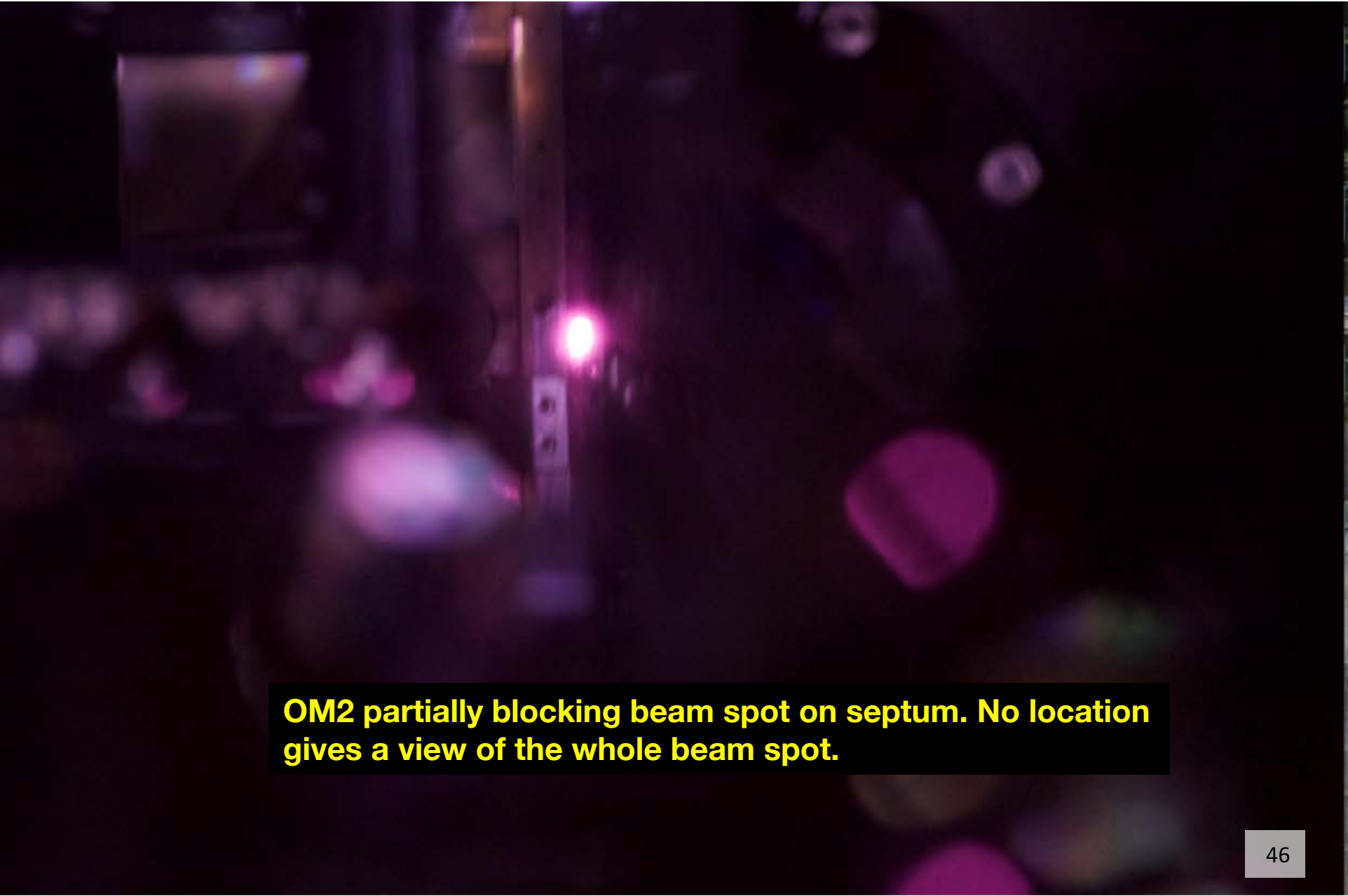
A dark, blurry photograph showing a bright, circular beam spot on a vertical surface, likely a septum. The spot is partially obscured by a vertical element labeled 'OM2'. The background is dark and indistinct.

**OM2 partially blocking beam spot on septum. No location gives a view of the whole beam spot.**

# LHO septum – overlay with in air photo

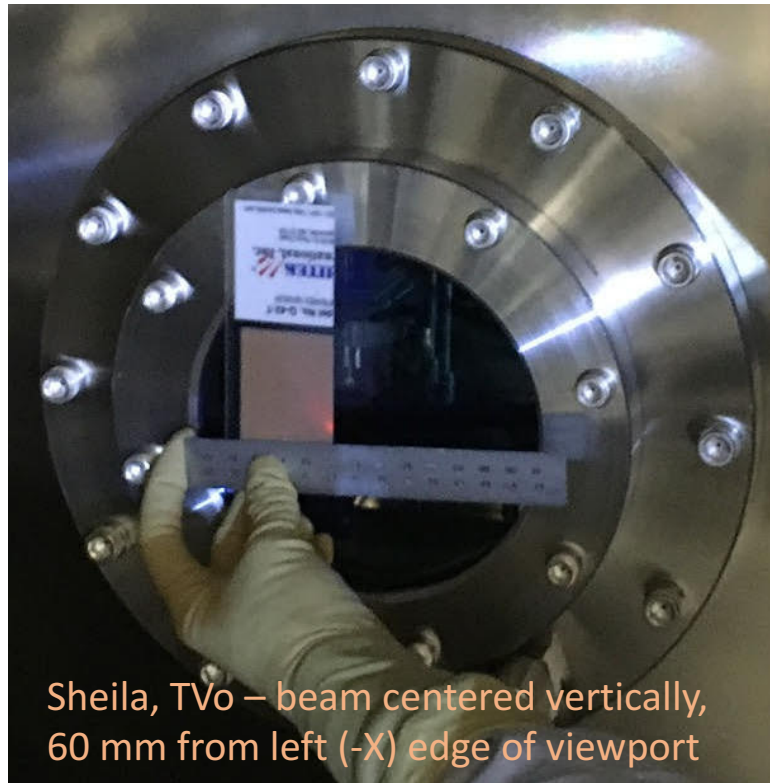

Sheila, TVo – beam centered vertically, 60 mm from left (-X) edge of viewport

-parallax of photo? – screws don't line up, card and ruler away from window  
-assume we can line up viewport size from head-on photo? 5.24" aperture

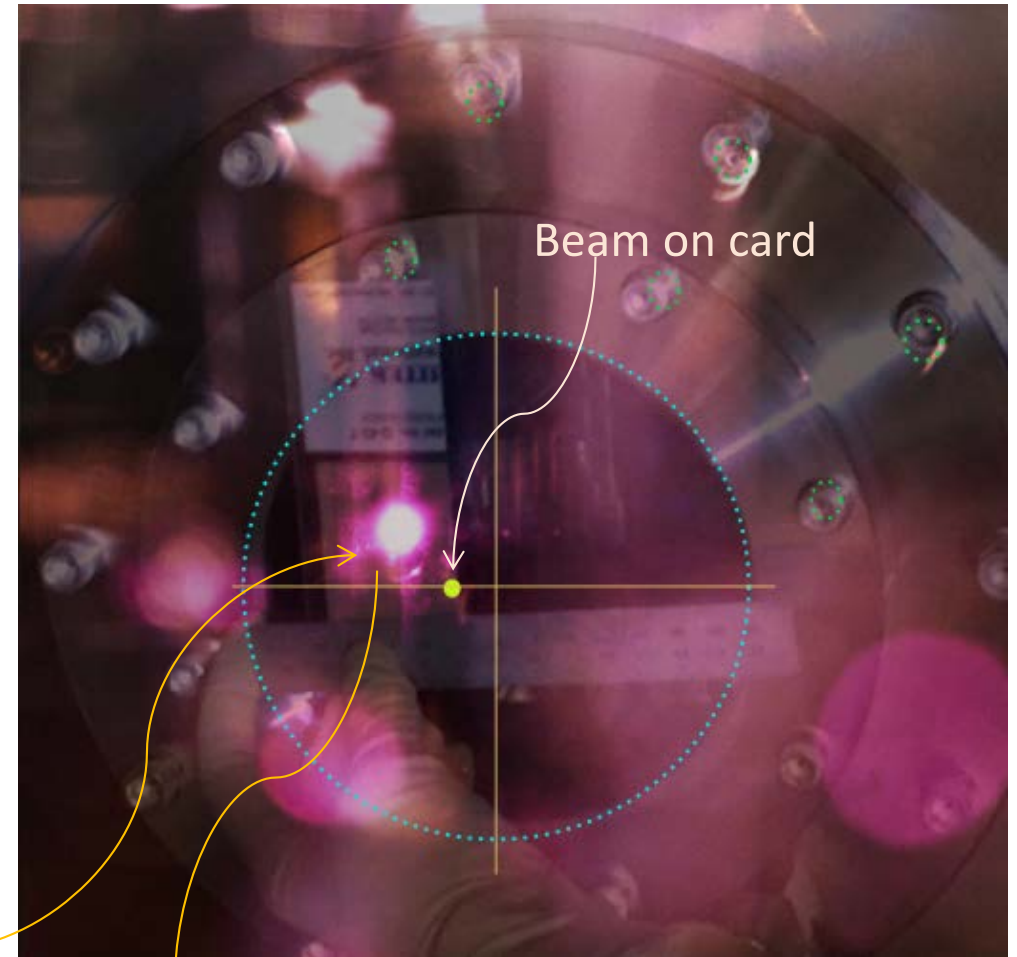

Beam on card

"scatter beam" ~15mm -X, ~15 mm up

## LLO HAM6 stray light photos

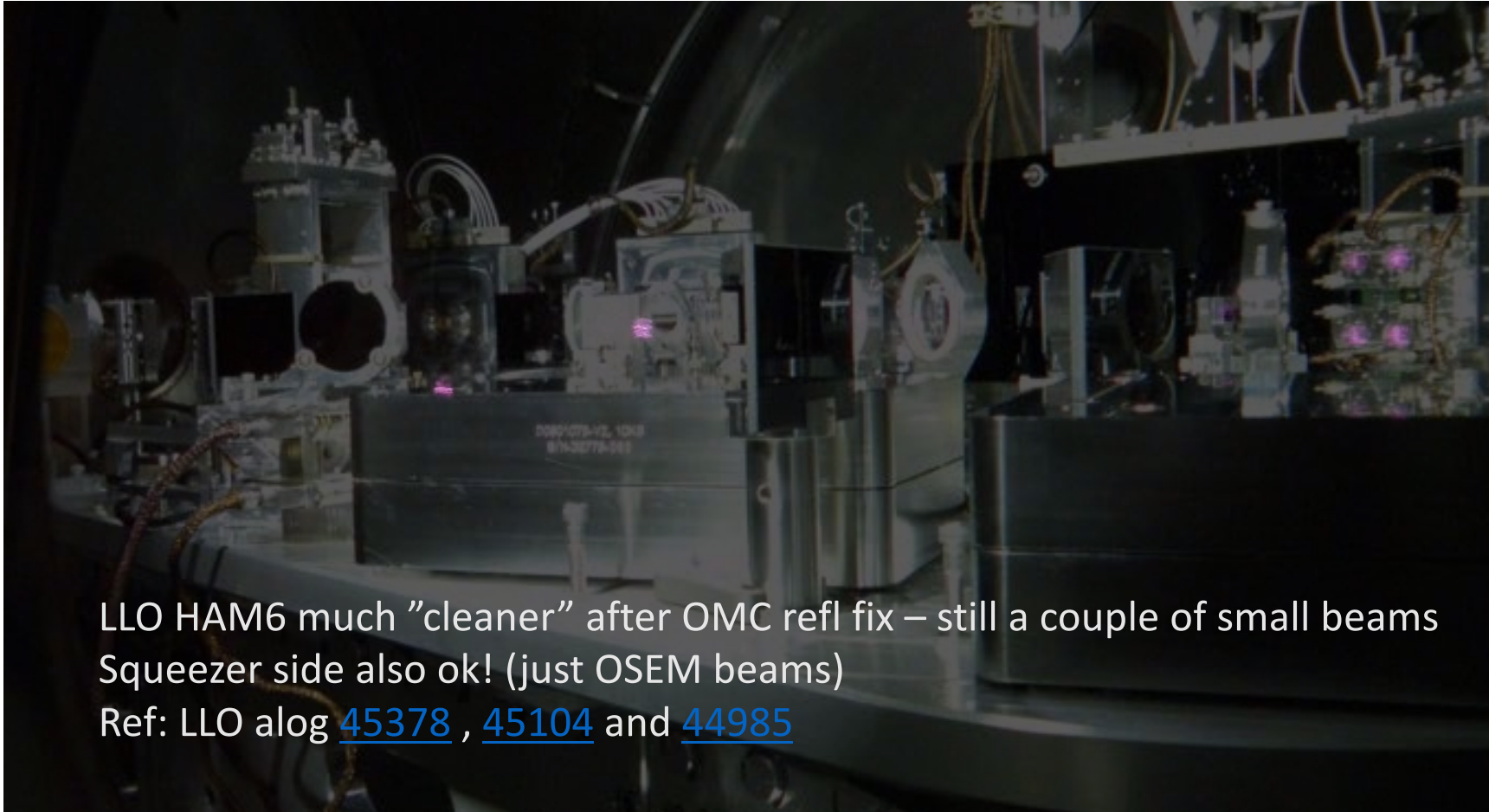

LLO HAM6 much "cleaner" after OMC refl fix – still a couple of small beams  
Squeezer side also ok! (just OSEM beams)

Ref: LLO alog [45378](#) , [45104](#) and [44985](#)



# LLO HAM5/6 SHAKER INJECTION CHECK

Not much change in coupling with the caveat that the reference measurement is from October

Ref: [LLO alog 46010](#)

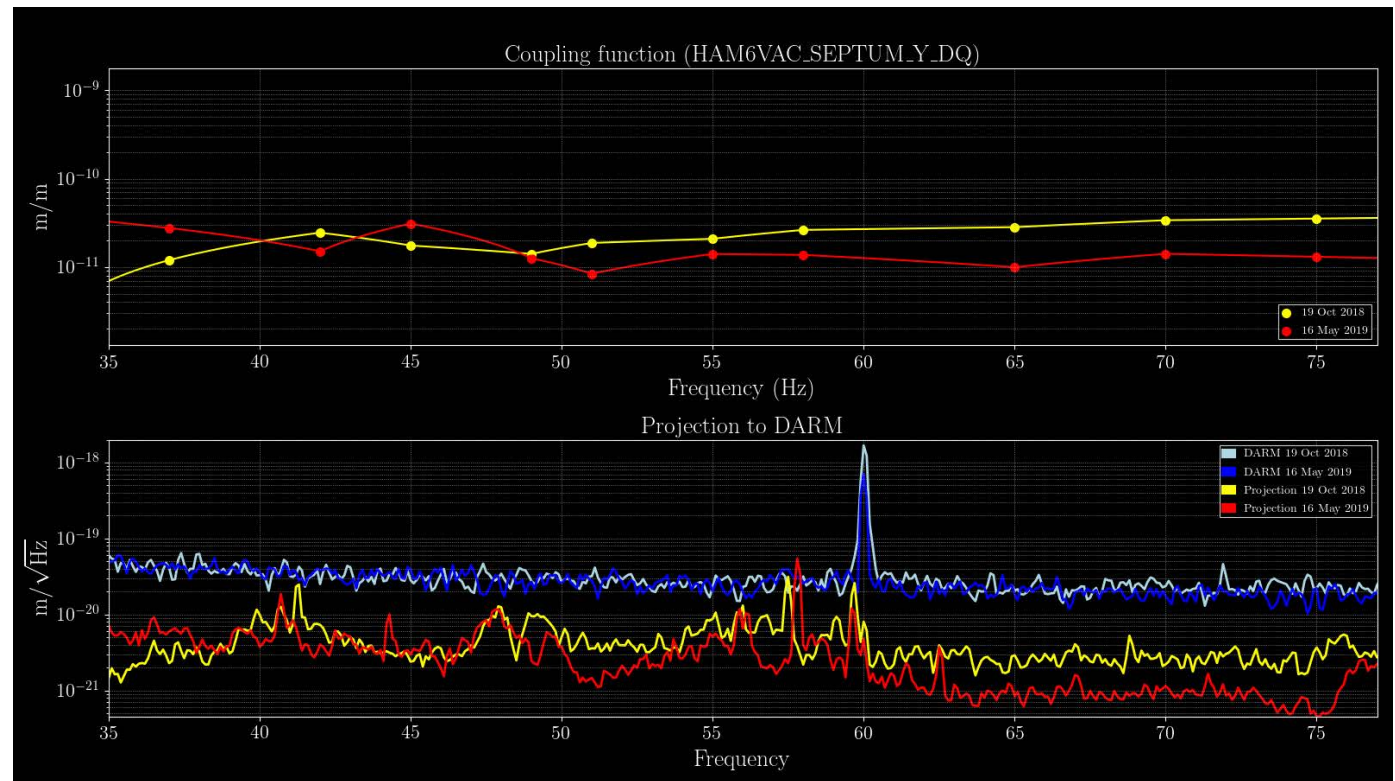

## Introduction

### A. Vibration coupling

- 1) LLO EX transmission monitor
- 2) Next worst sites at LLO are EY and HAM5/6 and, at LHO, HAM5/6 and the PSL
- 3) At both sites, HAM5/6 coupling is likely at the septum
- 4) EY coupling at LLO is likely in the manifold, at LHO, it may in the ETMY chamber
- 5) HAM5/6 coupling at the septum window?

*Other beam spots on LLO HAM6*

*OMC REFL beam not the cause of the main HAM5/6 scattering*

*HAM6 witness search at LLO*

#### 6) IO jitter coupling at both sites

- 7) Comparison of EY and EX in-lock photos
- 8) Shaker injections at EY produce noise similar to some anthropogenic noise
- 9) Other vibration coupling

*Beamtube shaking*

*Coupling at LHO BS chamber and at the reduction flanges by the optical lever*

*48 Hz peak at LHO*

*Reduction of 58 Hz chiller peak at LHO:*

#### 10) Vibration coupling not seen (at least 10 below DARM)

#### 11) Coupling estimates from PEM injections correctly predict environmental coupling

*LLO DARM glitch near S190510g is correctly predicted from PEM injection coupling functions.*

*Range reduction from LHO HVAC is roughly predicted from estimates for HAM5/6.*

*Range reduction from rain at LHO is roughly consistent with PEM coupling functions*

*Range reduction from wind at LHO is roughly consistent with PEM coupling functions.*

### B. Magnetic Coupling

### C. RF Coupling

### D. Site activities

# L1:IMC-WFS A I PITYAW QUADSUM - Composite Estimated Ambient (Coupling factors chosen based on loudest injection at each frequency)

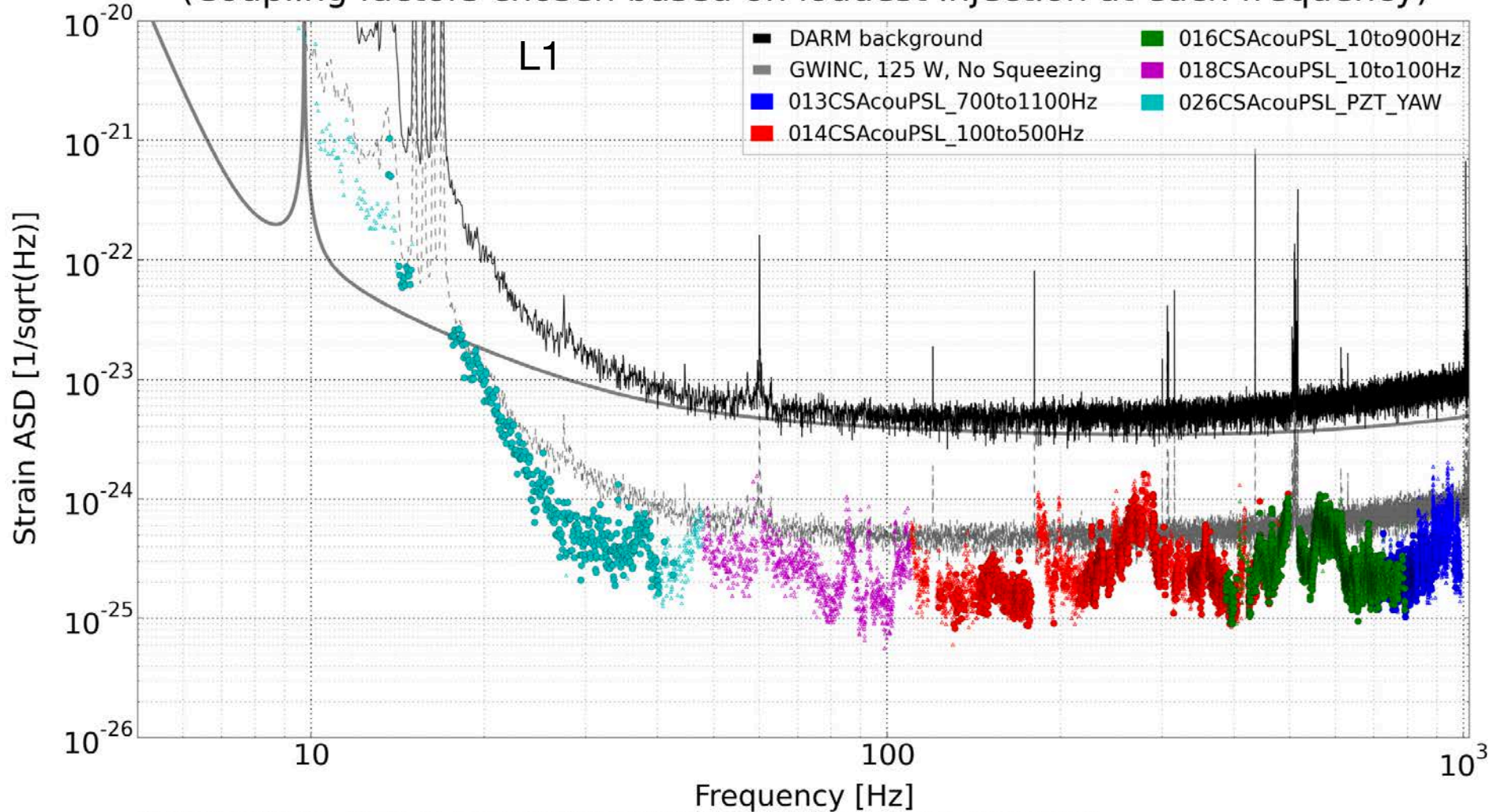

Ambient estimates are made by multiplying coupling factors by injection-free sensor levels. CIRCLES indicate estimates from measured coupling factors, i.e. where the injection signal was seen in the sensor and in DARM. TRIANGLES represent upper limit coupling factors, i.e. where a signal was not seen in DARM.

# H1:IMC-WFS A DC PITYAW QUADSUM - Composite Estimated Ambient (Coupling factors chosen based on loudest injection at each frequency)

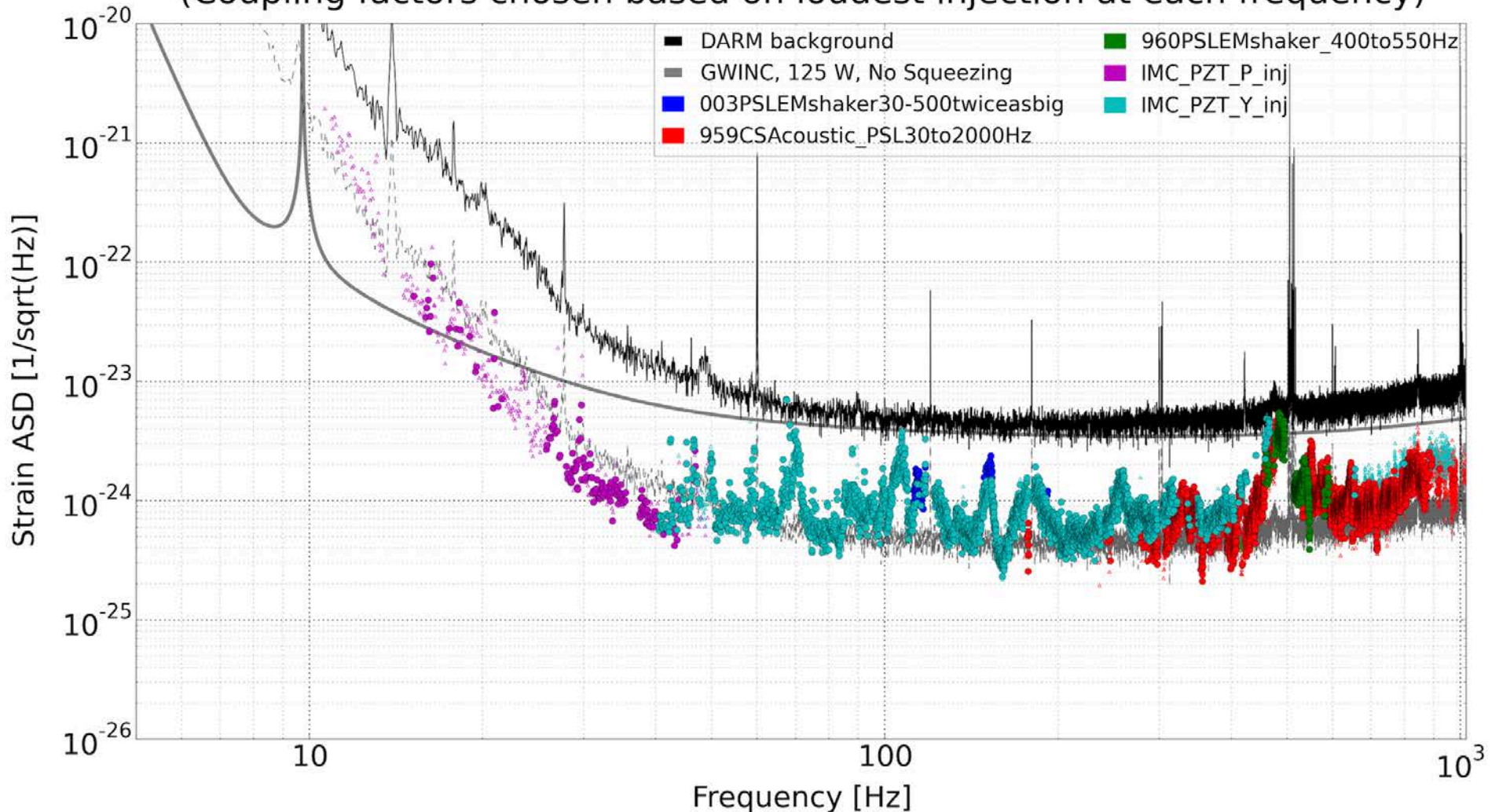

Ambient estimates are made by multiplying coupling factors by injection-free sensor levels. CIRCLES indicate estimates from measured coupling factors, i.e. where the injection signal was seen in the sensor and in DARM. TRIANGLES represent upper limit coupling factors, i.e. where a signal was not seen in DARM.

## Introduction

### A. Vibration coupling, worst sites

- 1) LLO EX transmission monitor
- 2) Next worst sites at LLO are EY and HAM5/6 and, at LHO, HAM5/6 and the PSL
- 3) At both sites, HAM5/6 coupling is likely at the septum
- 4) EY coupling at LLO is likely in the manifold, at LHO, it may in the ETMY chamber
- 5) HAM5/6 coupling at the septum window?

*Other beam spots on LLO HAM6*

*OMC REFL beam not the cause of the main HAM5/6 scattering*

*HAM6 witness search at LLO*

### 6) IO jitter coupling at both sites

### 7) Comparison of EY and EX in-lock photos

### 8) Shaker injections at EY produce noise similar to some anthropogenic noise

### 9) Other vibration coupling

*Beamtube shaking*

*Coupling at LHO BS chamber and at the reduction flanges by the optical lever*

*48 Hz peak at LHO*

*Reduction of 58 Hz chiller peak at LHO:*

### 10) Vibration coupling not seen (at least 10 below DARM)

### 11) Coupling estimates from PEM injections correctly predict environmental coupling

*LLO DARM glitch near S190510g is correctly predicted from PEM injection coupling functions.*

*Range reduction from LHO HVAC is roughly predicted from estimates for HAM5/6.*

*Range reduction from rain at LHO is roughly consistent with PEM coupling functions*

*Range reduction from wind at LHO is roughly consistent with PEM coupling functions.*

### B. Magnetic Coupling

### C. RF Coupling

### D. Site activities

# EX photos show M13 clip?

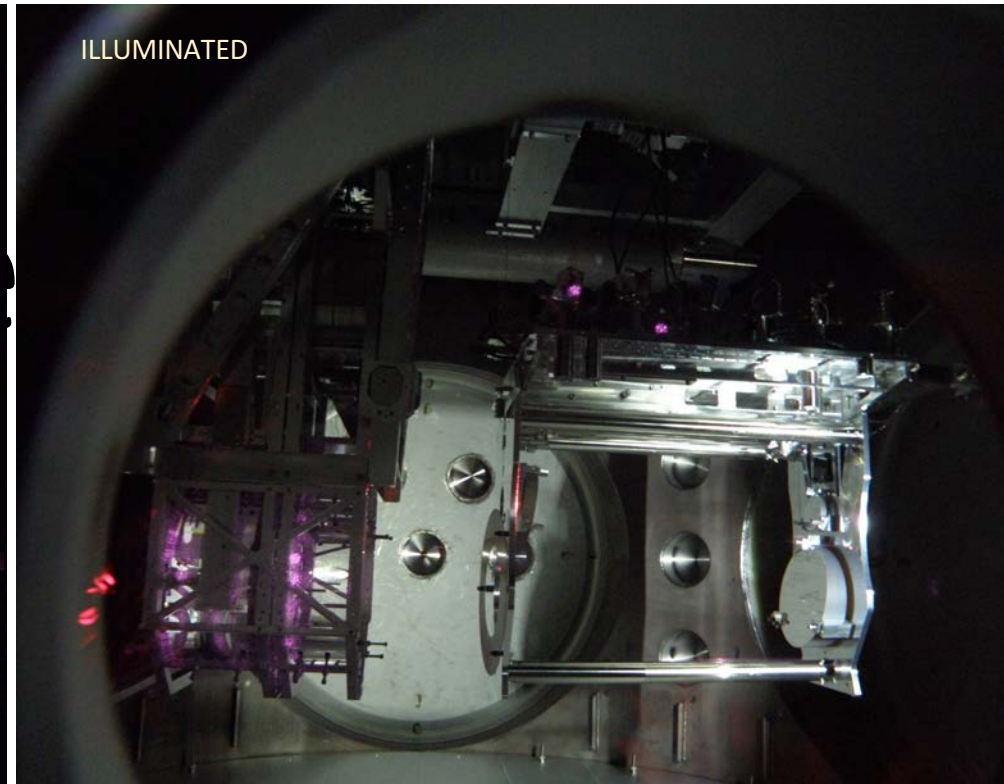

EX photos show M13 clip? Also at EY

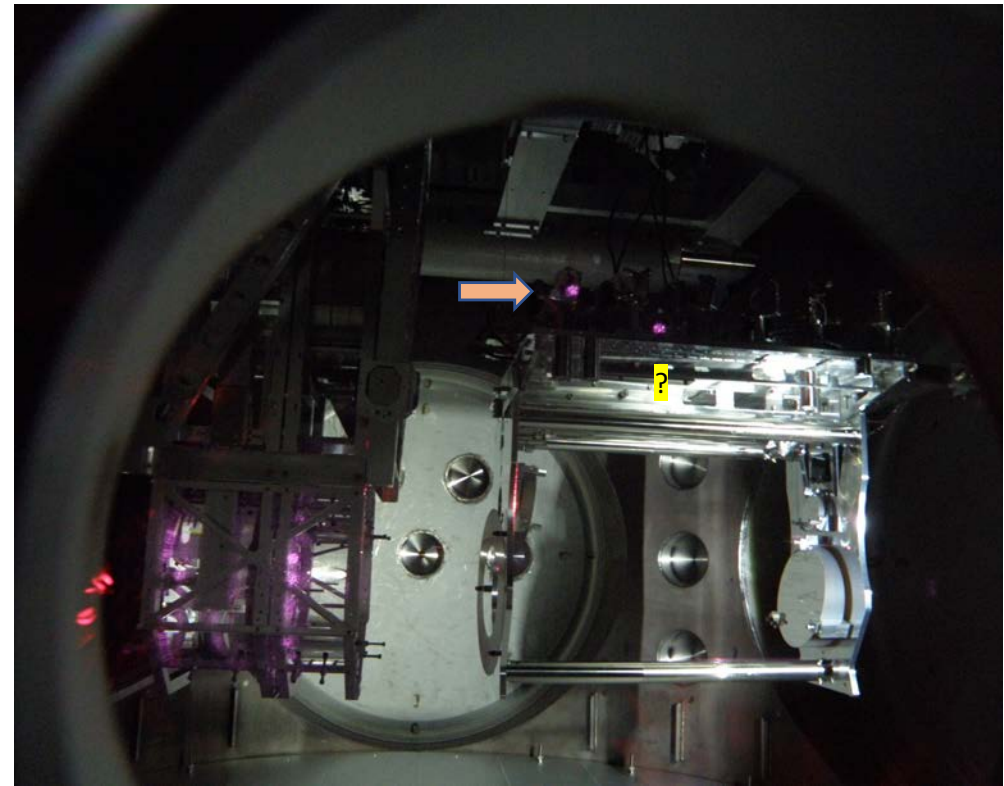
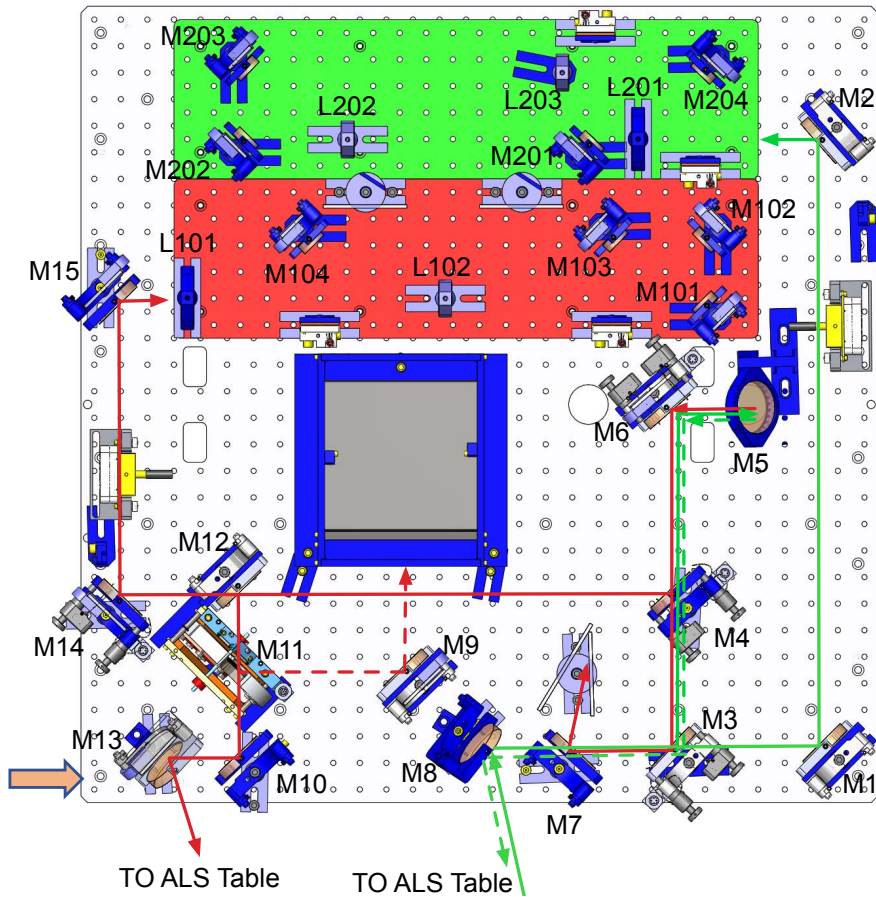

# LLO End Station Photos in Full Lock

- Stray beams on walls at EY
- Stray beams on ACB
- Some clipping on transmon optics
- Some beams on test masses?
- General brightness all over the cage, reaction mass
- Floors look “clean”
- *Unclear what matters*

Ref LLO alog: [45469](#) (needs update)

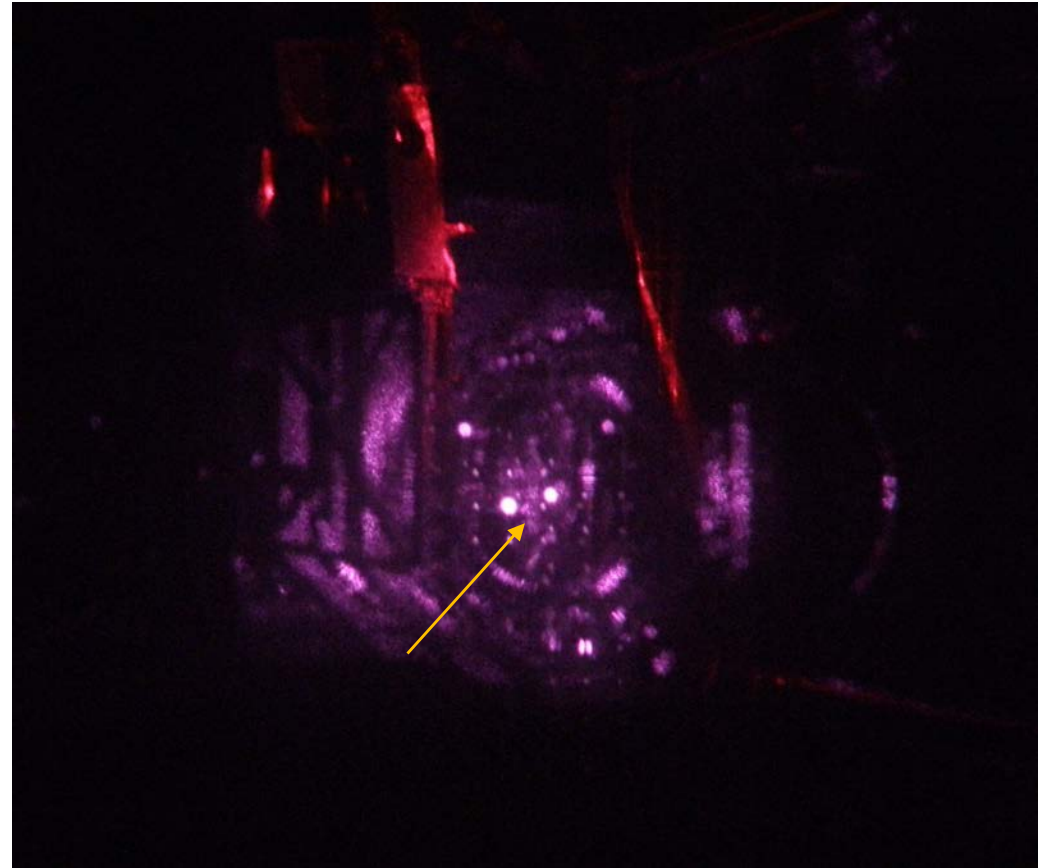



## Introduction

### A. Vibration coupling, worst sites

- 1) LLO EX transmission monitor
- 2) Next worst sites at LLO are EY and HAM5/6 and, at LHO, HAM5/6 and the PSL
- 3) At both sites, HAM5/6 coupling is likely at the septum
- 4) EY coupling at LLO is likely in the manifold, at LHO, it may in the ETMY chamber
- 5) HAM5/6 coupling at the septum window?

*Other beam spots on LLO HAM6*

*OMC REFL beam not the cause of the main HAM5/6 scattering*

*HAM6 witness search at LLO*

### 6) IO jitter coupling at both sites

### 7) Comparison of EY and EX in-lock photos

### 8) Shaker injections at EY produce noise similar to some anthropogenic noise

### 9) Other vibration coupling

*Beamtube shaking*

*Coupling at LHO BS chamber and at the reduction flanges by the optical lever*

*48 Hz peak at LHO*

*Reduction of 58 Hz chiller peak at LHO:*

### 10) Vibration coupling not seen (at least 10 below DARM)

### 11) Coupling estimates from PEM injections correctly predict environmental coupling

*LLO DARM glitch near S190510g is correctly predicted from PEM injection coupling functions.*

*Range reduction from LHO HVAC is roughly predicted from estimates for HAM5/6.*

*Range reduction from rain at LHO is roughly consistent with PEM coupling functions*

*Range reduction from wind at LHO is roughly consistent with PEM coupling functions.*

### B. Magnetic Coupling

### C. RF Coupling

### D. Site activities

Upconversion noise in DARM during a train

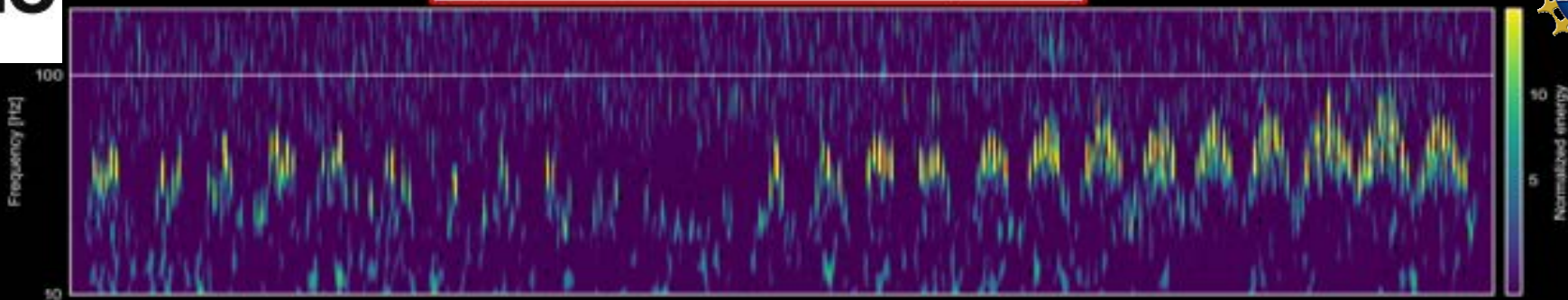

Upconversion noise in DARM during 3.8 Hz Injection at End-Y

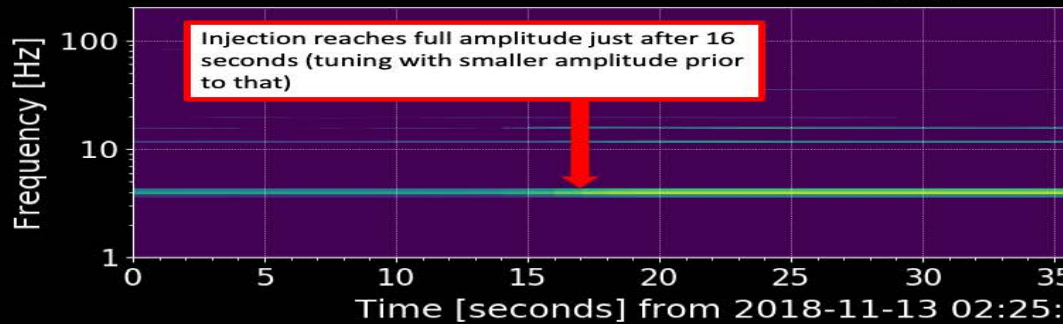
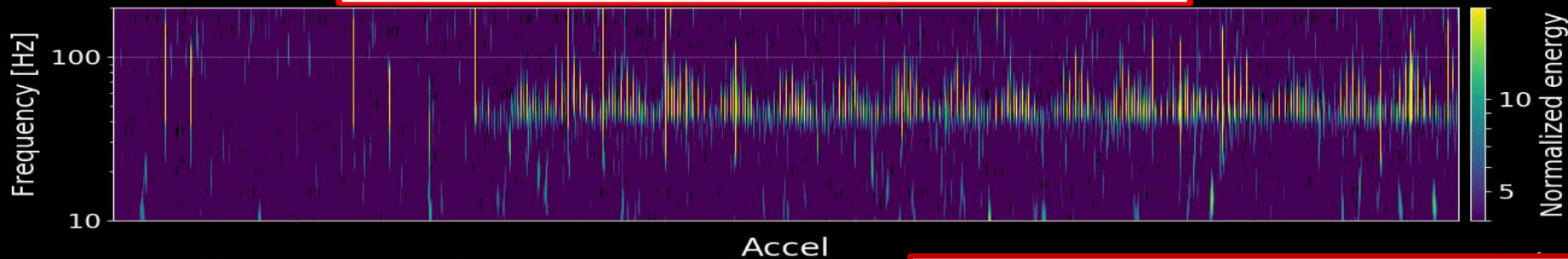

- Noise in DARM during train and during injection has similar shape ('fast' and 'slow' arches)
- Noise in DARM during injection starts when injection turns on (and off – not shown here)

## Introduction

### A. Vibration coupling, worst sites

- 1) LLO EX transmission monitor
- 2) Next worst sites at LLO are EY and HAM5/6 and, at LHO, HAM5/6 and the PSL
- 3) At both sites, HAM5/6 coupling is likely at the septum
- 4) EY coupling at LLO is likely in the manifold, at LHO, it may in the ETMY chamber
- 5) HAM5/6 coupling at the septum window?

*Other beam spots on LLO HAM6*

*OMC REFL beam not the cause of the main HAM5/6 scattering*

*HAM6 witness search at LLO*

- 6) IO jitter coupling at both sites
- 7) Comparison of EY and EX in-lock photos
- 8) Shaker injections at EY produce noise similar to some anthropogenic noise

### 9) Other vibration coupling

*Beamtube shaking*

*Coupling at LHO BS chamber and at the reduction flanges by the optical lever*

*48 Hz peak at LHO*

*Reduction of 58 Hz chiller peak at LHO:*

- 10) Vibration coupling not seen (at least 10 below DARM)
- 11) Coupling estimates from PEM injections correctly predict environmental coupling
  - LLO DARM glitch near S190510g is correctly predicted from PEM injection coupling functions.*
  - Range reduction from LHO HVAC is roughly predicted from estimates for HAM5/6.*
  - Range reduction from rain at LHO is roughly consistent with PEM coupling functions*
  - Range reduction from wind at LHO is roughly consistent with PEM coupling functions.*

### B. Magnetic Coupling

### C. RF Coupling

### D. Site activities

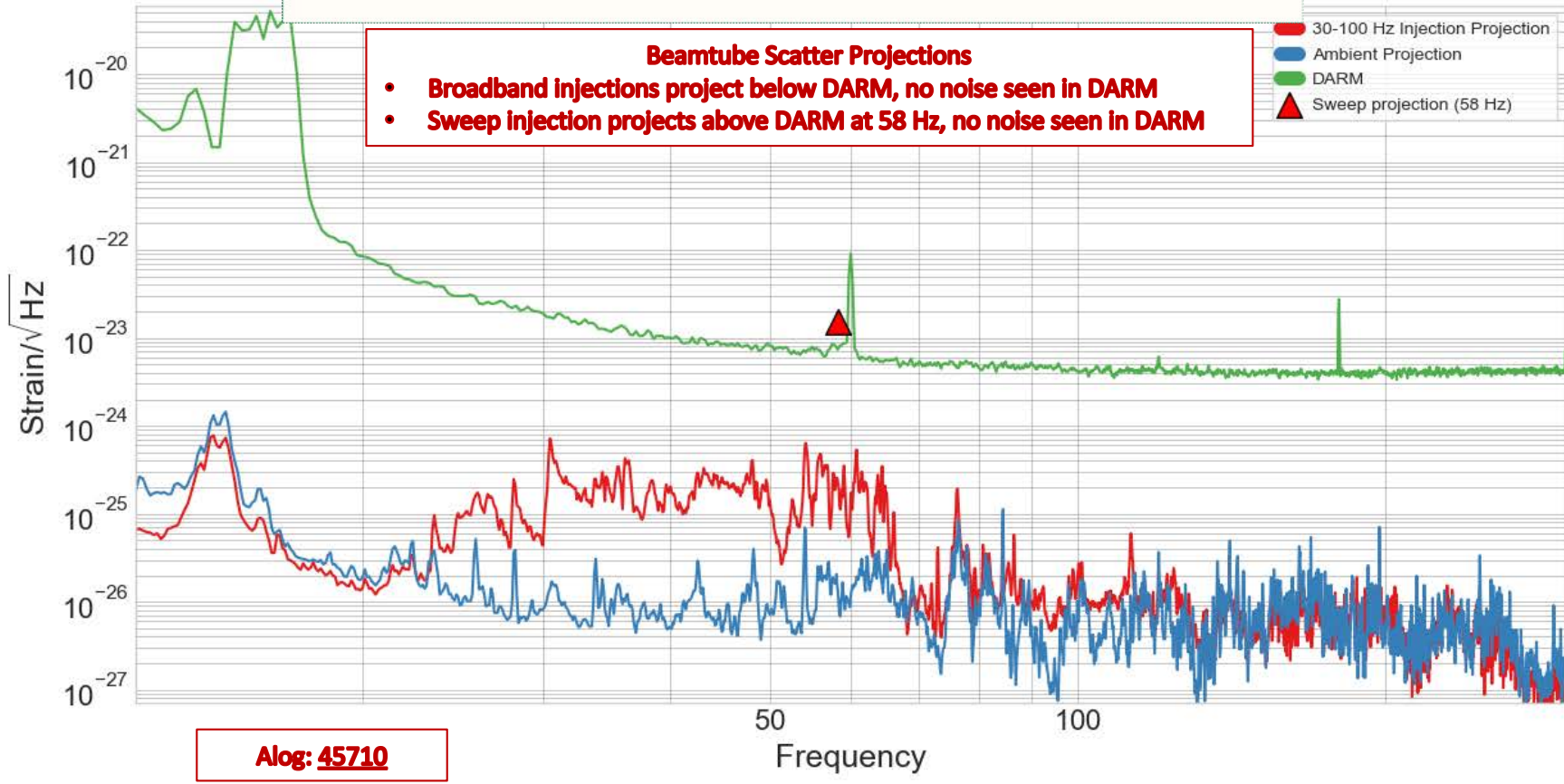
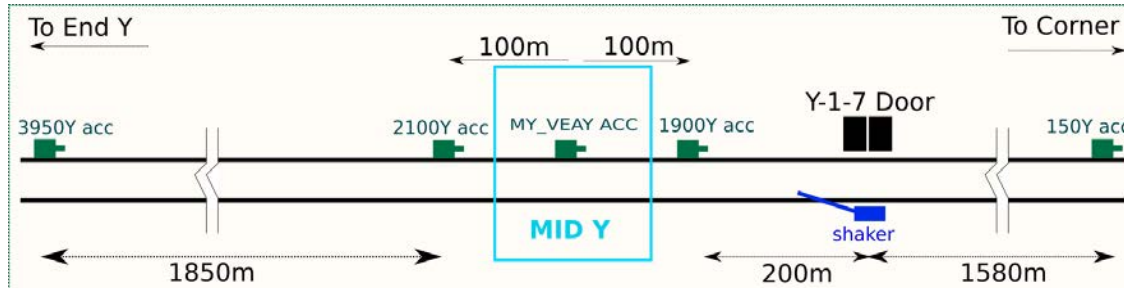



**Alog: 45710**



Beamtube 1900 Accel



**58 Hz: Factor of 1200 above ambient**

Beamtube 2100 Accel



**58 Hz: Factor of 800 above ambient**

CS 150 Accel

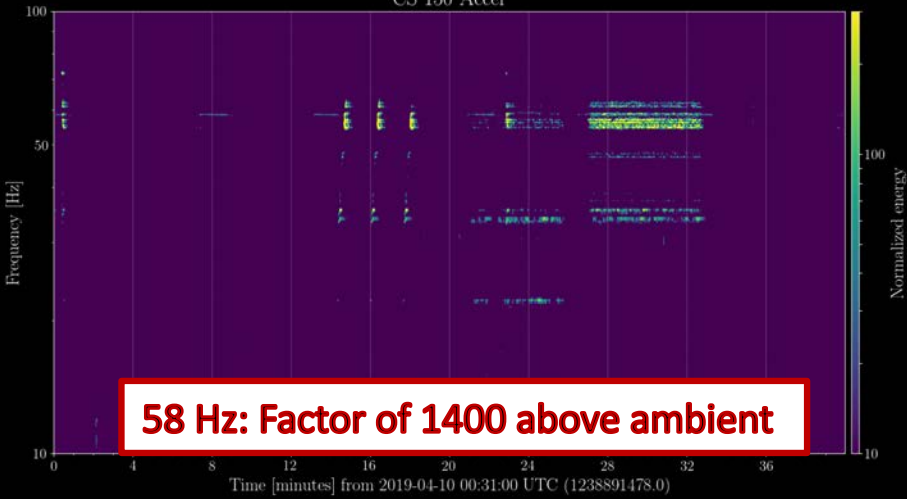

**58 Hz: Factor of 1400 above ambient**

EY 3950 Accel

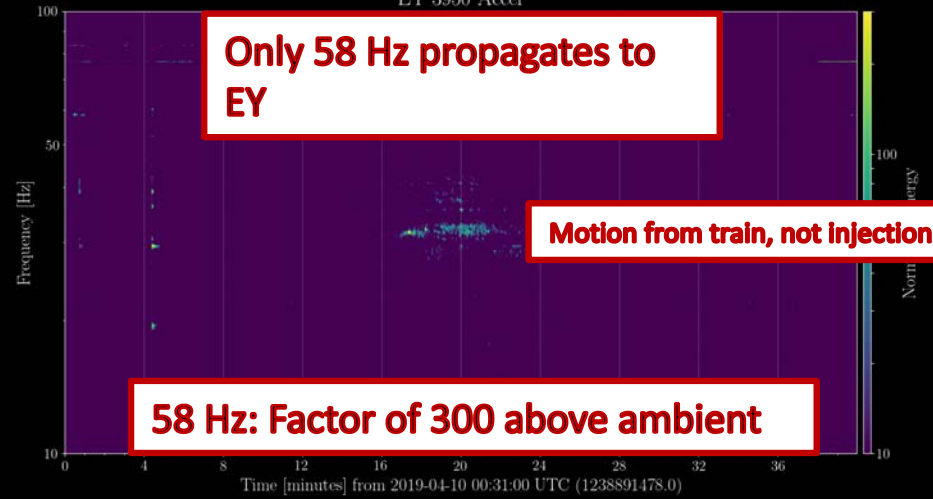

**Only 58 Hz propagates to EY**

**Motion from train, not injection**

**58 Hz: Factor of 300 above ambient**

## Introduction

### A. Vibration coupling, worst sites

- 1) LLO EX transmission monitor
- 2) Next worst sites at LLO are EY and HAM5/6 and, at LHO, HAM5/6 and the PSL
- 3) At both sites, HAM5/6 coupling is likely at the septum
- 4) EY coupling at LLO is likely in the manifold, at LHO, it may in the ETMY chamber
- 5) HAM5/6 coupling at the septum window?

*Other beam spots on LLO HAM6*

*OMC REFL beam not the cause of the main HAM5/6 scattering*

*HAM6 witness search at LLO*

- 6) IO jitter coupling at both sites
- 7) Comparison of EY and EX in-lock photos
- 8) Shaker injections at EY produce noise similar to some anthropogenic noise
- 9) Other vibration coupling

*Beamtube shaking*

*Coupling at LHO BS chamber and at the reduction flanges by the optical lever*

*48 Hz peak at LHO*

*Reduction of 58 Hz chiller peak at LHO:*

- 10) Vibration coupling not seen (at least 10 below DARM)
- 11) Coupling estimates from PEM injections correctly predict environmental coupling
  - LLO DARM glitch near S190510g is correctly predicted from PEM injection coupling functions.*
  - Range reduction from LHO HVAC is roughly predicted from estimates for HAM5/6.*
  - Range reduction from rain at LHO is roughly consistent with PEM coupling functions*
  - Range reduction from wind at LHO is roughly consistent with PEM coupling functions.*

### B. Magnetic Coupling

### C. RF Coupling

### D. Site activities

# Shaking of BSC2 wall

# Impulse

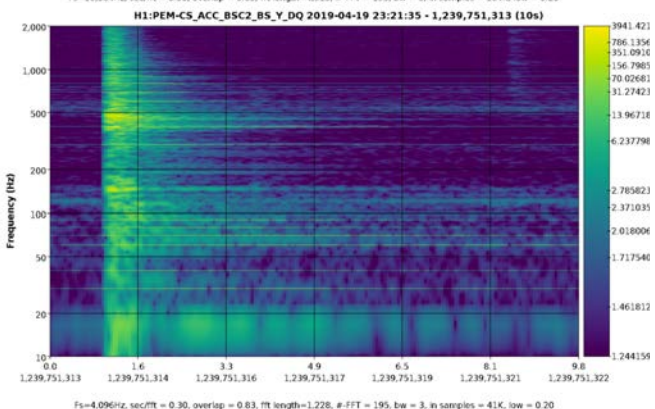
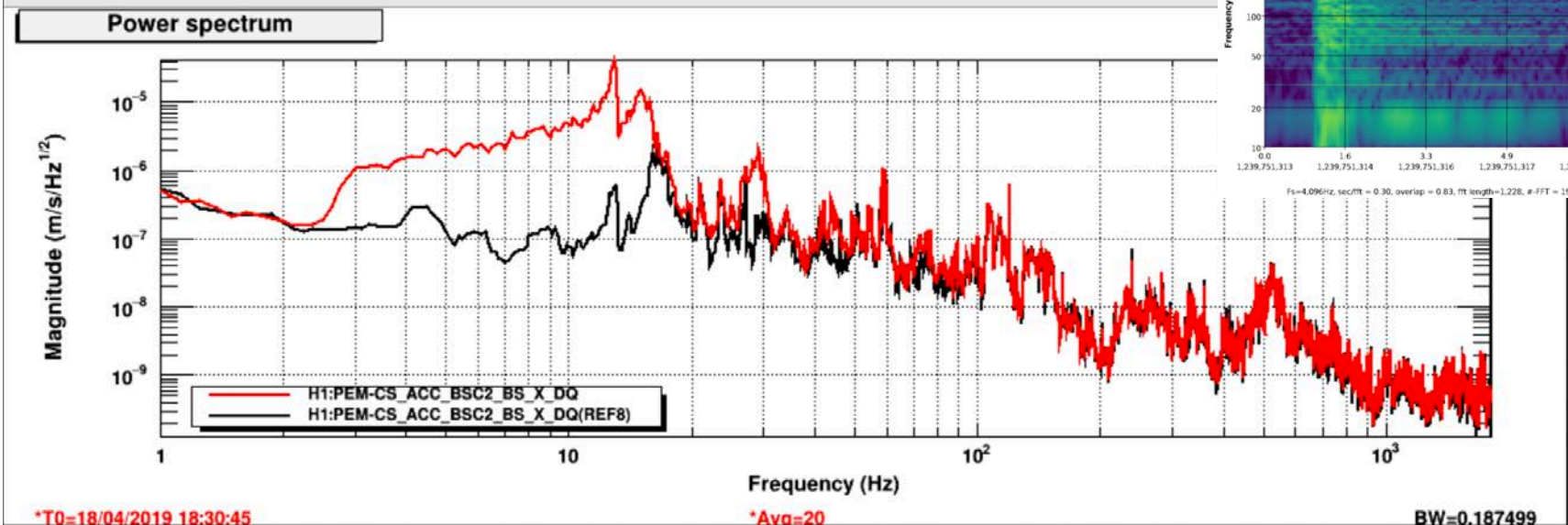
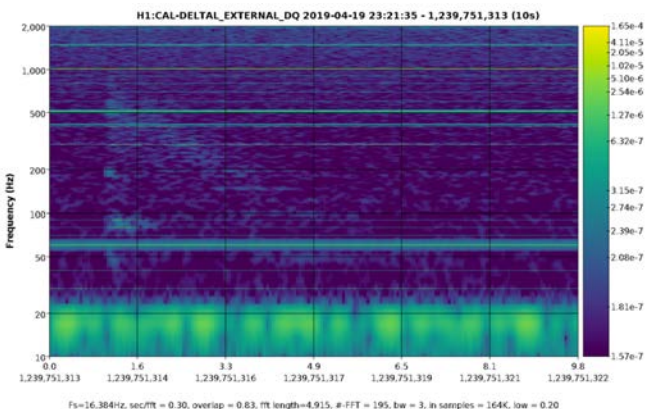
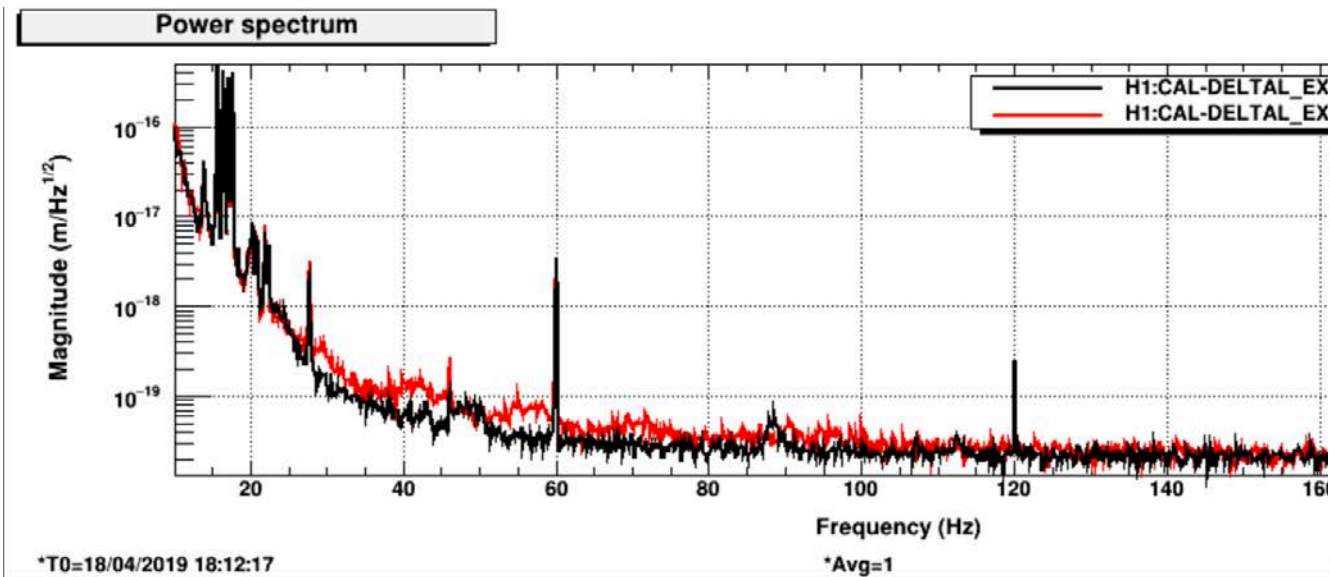

# Shaking of manifold reduction flange near ITMX optical lever

Power spectrum

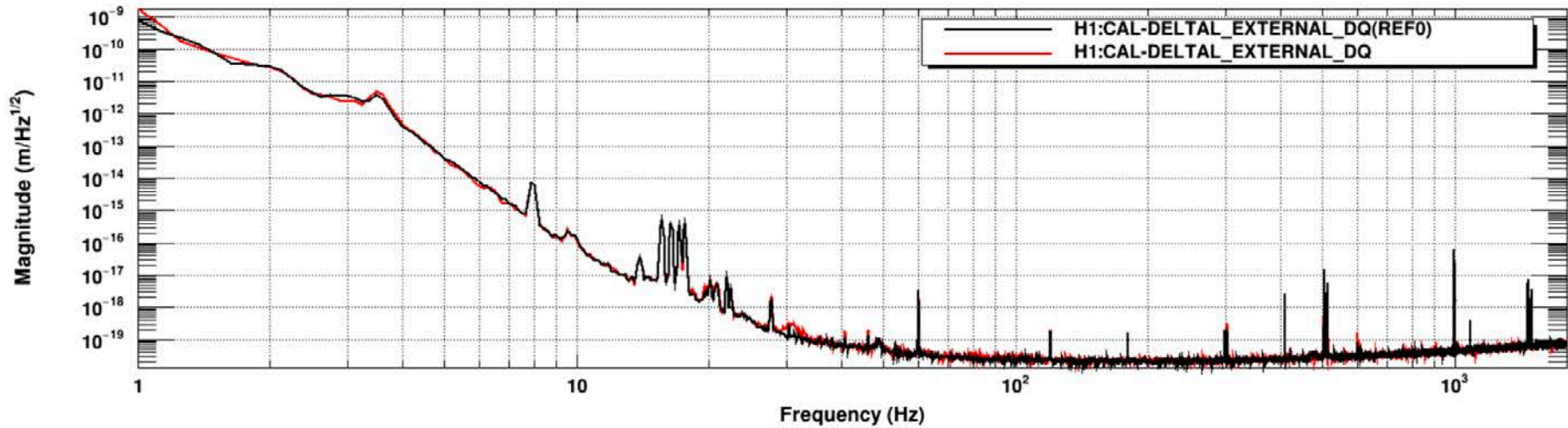

\*T0=19/04/2019 22:21:42

\*Avg=1

BW=0.187499

Power spectrum

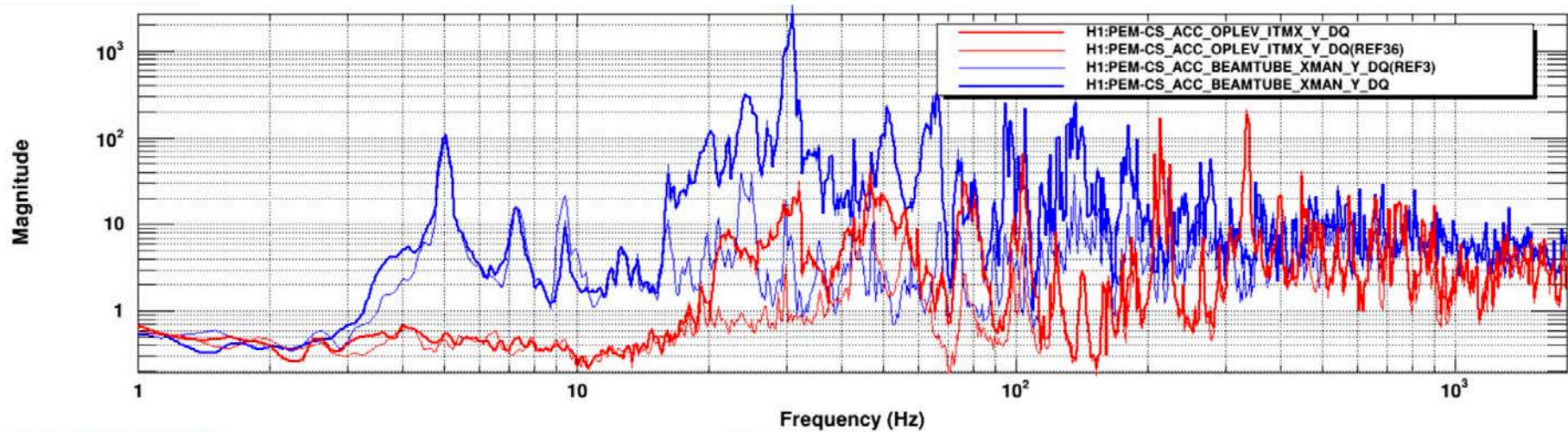

\*T0=19/04/2019 22:51:35

\*Avg=20/Bin=11L

BW=0.187499



# LLO LVEA Y TUBE INJECTIONS (still to analyze)

**Y Red. Flange INJ**

**BSC1 INJ**

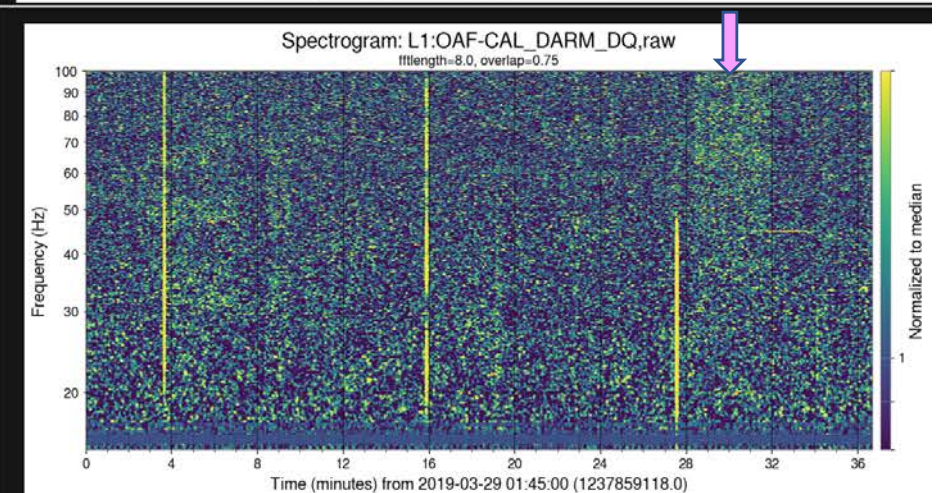
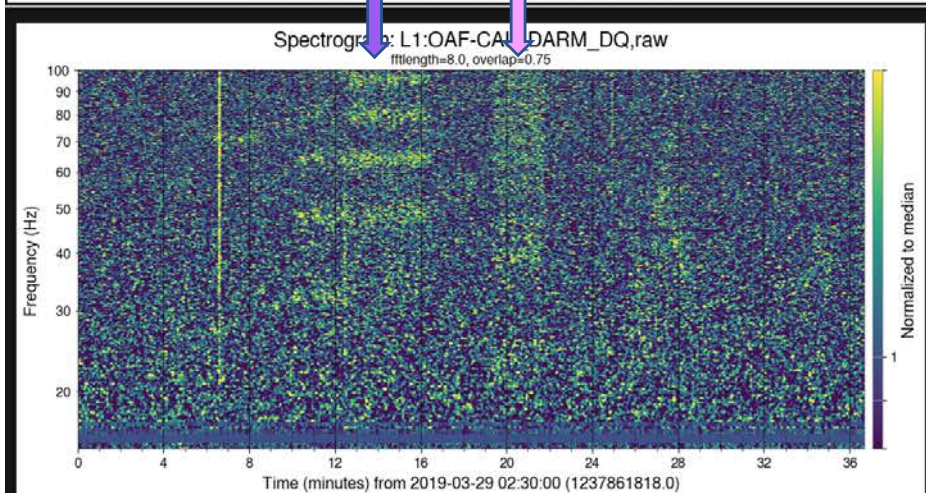
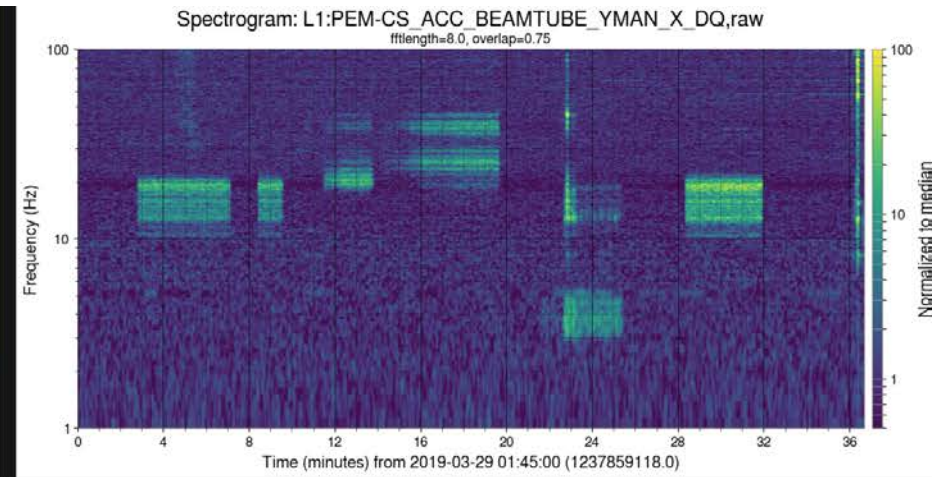
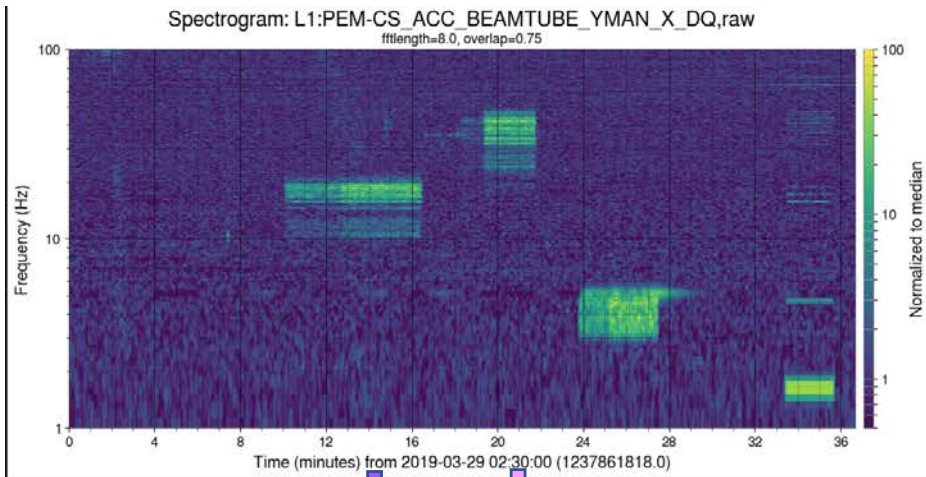

## Introduction

### A. Vibration coupling, worst sites

- 1) LLO EX transmission monitor
- 2) Next worst sites at LLO are EY and HAM5/6 and, at LHO, HAM5/6 and the PSL
- 3) At both sites, HAM5/6 coupling is likely at the septum
- 4) EY coupling at LLO is likely in the manifold, at LHO, it may in the ETMY chamber
- 5) HAM5/6 coupling at the septum window?

*Other beam spots on LLO HAM6*

*OMC REFL beam not the cause of the main HAM5/6 scattering*

*HAM6 witness search at LLO*

- 6) IO jitter coupling at both sites
- 7) Comparison of EY and EX in-lock photos
- 8) Shaker injections at EY produce noise similar to some anthropogenic noise
- 9) Other vibration coupling

*Beamtube shaking*

*Coupling at LHO BS chamber and at the reduction flanges by the optical lever*

*48 Hz peak at LHO*

*Reduction of 58 Hz chiller peak at LHO*

- 10) Vibration coupling not seen (at least 10 below DARM)
- 11) Coupling estimates from PEM injections correctly predict environmental coupling
  - LLO DARM glitch near S190510g is correctly predicted from PEM injection coupling functions.*
  - Range reduction from LHO HVAC is roughly predicted from estimates for HAM5/6.*
  - Range reduction from rain at LHO is roughly consistent with PEM coupling functions*
  - Range reduction from wind at LHO is roughly consistent with PEM coupling functions.*

### B. Magnetic Coupling

### C. RF Coupling

### D. Site activities

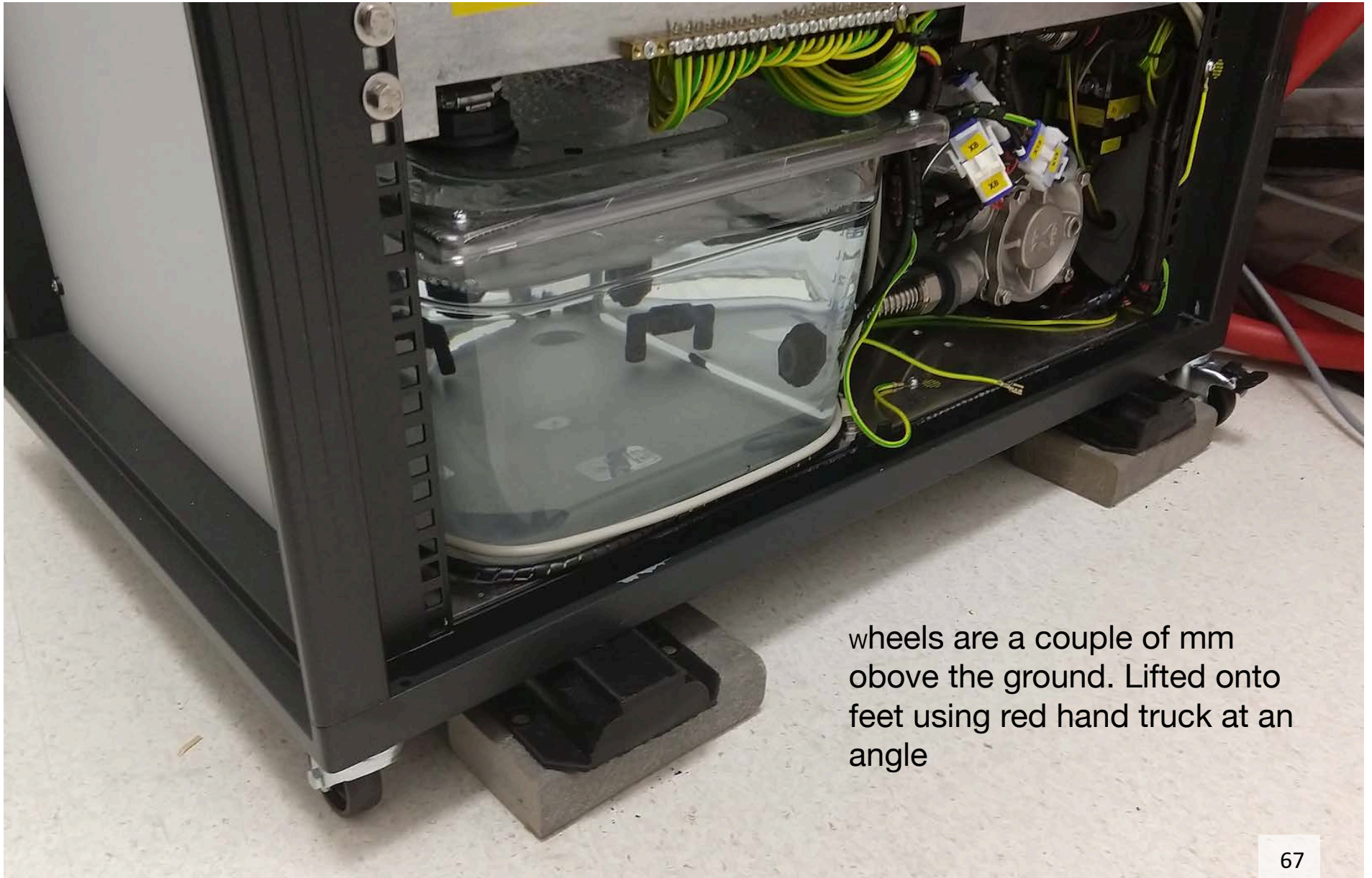

wheels are a couple of mm above the ground. Lifted onto feet using red hand truck at an angle

## Introduction

### A. Vibration coupling, worst sites

- 1) LLO EX transmission monitor
- 2) Next worst sites at LLO are EY and HAM5/6 and, at LHO, HAM5/6 and the PSL
- 3) At both sites, HAM5/6 coupling is likely at the septum
- 4) EY coupling at LLO is likely in the manifold, at LHO, it may in the ETMY chamber
- 5) HAM5/6 coupling at the septum window?

*Other beam spots on LLO HAM6*

*OMC REFL beam not the cause of the main HAM5/6 scattering*

*HAM6 witness search at LLO*

- 6) IO jitter coupling at both sites
- 7) Comparison of EY and EX in-lock photos
- 8) Shaker injections at EY produce noise similar to some anthropogenic noise
- 9) Other vibration coupling

*Beamtube shaking*

*Coupling at LHO BS chamber and at the reduction flanges by the optical lever*

*48 Hz peak at LHO*

*Reduction of 58 Hz chiller peak at LHO:*

### 10) Vibration coupling not seen (at least 10 below DARM)

#### 11) Coupling estimates from PEM injections correctly predict environmental coupling

*LLO DARM glitch near S190510g is correctly predicted from PEM injection coupling functions.*

*Range reduction from LHO HVAC is roughly predicted from estimates for HAM5/6.*

*Range reduction from rain at LHO is roughly consistent with PEM coupling functions*

*Range reduction from wind at LHO is roughly consistent with PEM coupling functions.*

### B. Magnetic Coupling

### C. RF Coupling

### D. Site activities



# No coupling (to x10 or better)

---

Site	Location	Injection Type	Relevant to
LHO, LLO	mids	Acoustic/shaker 10-100 Hz	Beamtube scatter
LHO, LLO	IOT2L (IMC table)	Acoustic/shaker 10-100 Hz	Local coupling
LHO, LLO	IMC tube (HAM2-3)	Shaker 5-100 Hz	Local coupling
LHO	HEPI EX, EY, BS, IX, IY	HEPI Inj 1-100 Hz, beam dof	ACB, BS baffles, scatter
LLO	ISI all BSC and HAM	ISI Inj 1-5 Hz, beam and r dofs	Daytime scatter
LLO	Arm beamtube	Shaker ~58 Hz	Beamtube scatter
LHO, LLO	SRC tube (HAM4-5)	Shaker 5-100 Hz	Local coupling

## Introduction

### A. Vibration coupling, worst sites

- 1) LLO EX transmission monitor
- 2) Next worst sites at LLO are EY and HAM5/6 and, at LHO, HAM5/6 and the PSL
- 3) At both sites, HAM5/6 coupling is likely at the septum
- 4) EY coupling at LLO is likely in the manifold, at LHO, it may in the ETMY chamber
- 5) HAM5/6 coupling at the septum window?

*Other beam spots on LLO HAM6*

*OMC REFL beam not the cause of the main HAM5/6 scattering*

*HAM6 witness search at LLO*

- 6) IO jitter coupling at both sites
- 7) Comparison of EY and EX in-lock photos
- 8) Shaker injections at EY produce noise similar to some anthropogenic noise
- 9) Other vibration coupling

*Beamtube shaking*

*Coupling at LHO BS chamber and at the reduction flanges by the optical lever*

*48 Hz peak at LHO*

*Reduction of 58 Hz chiller peak at LHO:*

- 10) Vibration coupling not seen (at least 10 below DARM)

### 11) Coupling estimates from PEM injections correctly predict environmental coupling

*LLO DARM glitch near S190510g is correctly predicted from PEM injection coupling functions.*

*Range reduction from LHO HVAC is roughly predicted from estimates for HAM5/6.*

*Range reduction from rain at LHO is roughly consistent with PEM coupling functions*

*Range reduction from wind at LHO is roughly consistent with PEM coupling functions.*

### B. Magnetic Coupling

### C. RF Coupling

### D. Site activities

**L1 PEM (Detchar, PEM)**



philippe.nguyen@LIGO.ORG - posted 15:21, Friday 17 May 2019 (46025)

**Coupling estimates from PEM injections correctly predict LLO DARM glitch near S190510g from thunder-driven vibration at EY**

Philippe N, Robert S,

We looked at a long duration Omega scan covering the 20 seconds before the event time of S190510g (where the most scattering noise was observed) and found that many L1 PEM accelerometers and microphones saw excess noise around the same time as the noise in DARM. I ran my own offline version of the DQR PEM check on this Omega scan to estimate coupling into DARM. The coupling functions predict the highest contribution at EY, with several EY accelerometers roughly predicting the 11.5 SNR in DARM reported by the omegascan.

Link to the omegascan report: <https://ldas-jobs.ligo-la.caltech.edu/~philippe.nguyen/omega/1241492387/>

Link to the pemcheck results: <https://ldas-jobs.ligo-la.caltech.edu/~philippe.nguyen/omega/1241492387/pemcheck-results.html>

The DQR Omega scan is configured to a search window duration of only +/- 0.5 s around event time, regardless of the template duration, so the DQR PEM check, which relies on the output of that scan, could not provide the above predictions. If those Omega scans were expanded (by having a fixed, longer-duration scan, by adapting the searchWindowDuration config option to cover the template duration, or by simply re-running them by hand), the PEM check would be able to make more useful estimates.

The vibration source that produced the signal in DARM is likely distant thunder: the signals show up at all stations with reasonable delays for sound propagation, sound like thunder in mp3s, have the right frequency content and duration, and one of the loud events was consistent with the time put in by an operator for a loud thunder clap.

The second page of the attached pdf shows that events in DARM are coincident with the EY mic, but not the mics at the other stations. Because thunder is a global injection with time delays, it is a good test of dominant vibration coupling sites. Our shaker injections suggested that EY is the dominant coupling site in this band. The PEM injection results are supported by the correct prediction of the DARM event by the EY accelerometer and the absence of DARM events for other stations.

Below are links to Omega scans covering the other two thunder events and their PEM checks, which show that the EY coupling predicts the DARM amplitudes for those events as well:

<https://ldas-jobs.ligo-la.caltech.edu/~philippe.nguyen/omega/1241493373/>

### ✓ L1:GDS-CALIB\_STRAIN

most significant tile:  $t = 1241492384.438$  s,  $f = 46.6$  Hz,  $Q = 50.6$ ,  $Z = 6.6 \times 10^1$ ,  $X = 7.5 \times 10^{-23}$  Hz<sup>-1/2</sup>, SNR = 11.5

time series: [raw](#), [high passed](#), [whitened](#) | spectrogram: [raw](#), [whitened](#), [autoscaled](#) | eventgram: [raw](#), [whitened](#), [autoscaled](#)

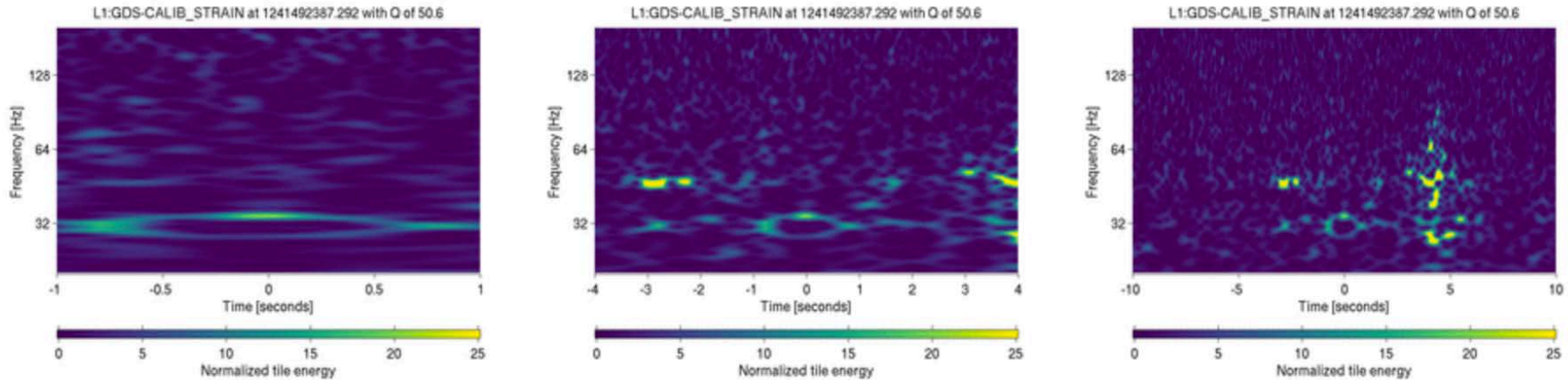

### ✓ L1:PEM-EY\_ACC\_BEAMTUBE\_MAN\_Y\_DQ

most significant tile:  $t = 1241492390.906$  s,  $f = 30.9$  Hz,  $Q = 20.0$ ,  $Z = 3.2 \times 10^2$ ,  $X = 6.2 \times 10^1$  Hz<sup>-1/2</sup>, SNR = 25.4

time series: [raw](#), [high passed](#), [whitened](#) | spectrogram: [raw](#), [whitened](#), [autoscaled](#) | eventgram: [raw](#), [whitened](#), [autoscaled](#)

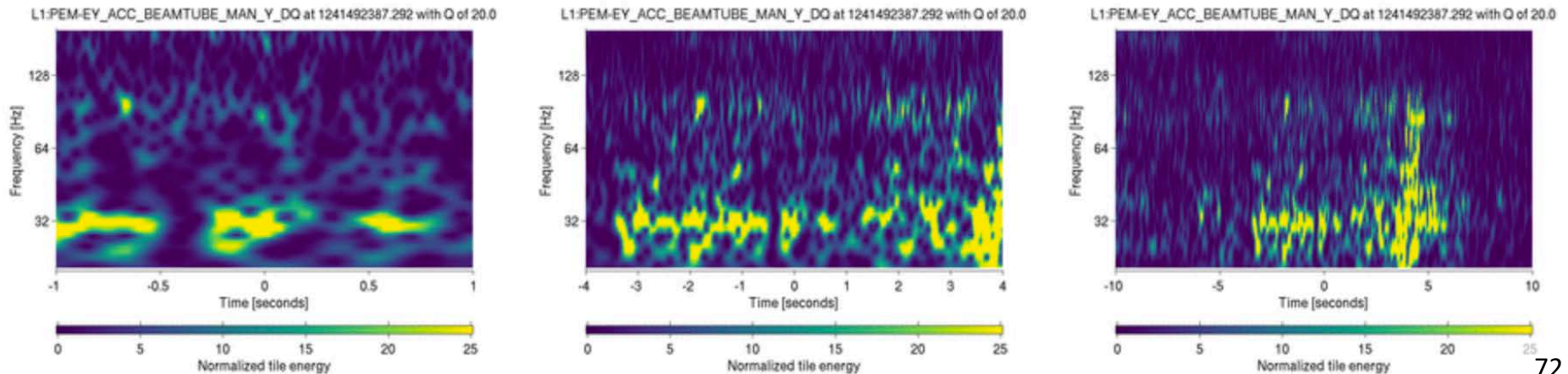



a

Channel	Peak frequency	Peak amplitude	Coupling function at peak freq	Coupling function flag	Estimated DARM amplitude	DARM background	Estimated amplitude / bkgd
L1:PEM-EY_ACC_BEAMTUBE_MAN_Y_DQ	30.9	6.2e+01	1.7e-20	Upper Limit	1.0e-18	7.6e-20	13.85
L1:PEM-EY_ACC_BSC5_ETMY_X_DQ	47.3	3.7e+01	7.6e-21	Measured	2.8e-19	3.4e-20	8.31
L1:PEM-EY_ACC_BSC5_ETMY_Y_DQ	47.3	9.6e+01	2.9e-21	Measured	2.7e-19	3.4e-20	8.17
L1:PEM-EY_ACC_VEA_FLOOR_Z_DQ	32.7	1.3e+01	3.0e-20	Upper Limit	3.9e-19	5.9e-20	6.70
L1:PEM-EY_ACC_BEAMTUBE_MAN_Z_DQ	47.3	3.9e+01	5.0e-21	Measured	2.0e-19	3.4e-20	5.89
L1:PEM-EX_ACC_BSC4_ETMX_X_DQ	28.1	2.2e+01	1.4e-20	Upper Limit	3.1e-19	7.2e-20	4.33
L1:PEM-EY_ACC_OPLEV_ETMY_X_DQ	56.9	4.2e+01	2.7e-21	Measured	1.2e-19	2.8e-20	4.19
L1:PEM-CS_ACC_BEAMTUBE_MCTUBE_Y_DQ	37.9	1.6e+01	9.3e-21	Upper Limit	1.5e-19	4.1e-20	3.58
L1:PEM-EY_ACC_BSC5_ETMY_Z_DQ	32.7	1.3e+01	1.5e-20	Upper Limit	2.0e-19	5.9e-20	3.48
L1:PEM-EY_MIC_VEA_PLUSY_DQ	48.2	9.2e+01	1.2e-21	Measured	1.1e-19	3.1e-20	3.39
L1:PEM-CS_ACC_ISCT1_REFL_Y_DQ	38.8	1.0e+01	6.9e-21	Upper Limit	7.1e-20	4.0e-20	1.78
L1:PEM-EX_ACC_BSC4_ETMX_Z_DQ	26.8	3.5e+00	4.9e-20	Upper Limit	1.7e-19	1.1e-19	1.56
L1:PEM-EX_ACC_OPLEV_ETMX_Y_DQ	37.2	3.6e+00	2.1e-20	Upper Limit	7.5e-20	4.9e-20	1.52
L1:PEM-CS_ACC_LVEAFLOOR_HAM1_Z_DQ	24.5	1.7e+00	9.8e-20	Upper Limit	1.7e-19	1.2e-19	1.42
L1:PEM-EX_MIC_EBAY_RACKS_DQ	21.6	2.0e+01	1.2e-20	Upper Limit	2.5e-19	1.8e-19	1.37
L1:PEM-EX_ACC_VEA_FLOOR_Z_DQ	26.8	3.5e+00	3.9e-20	Upper Limit	1.4e-19	1.0e-19	1.31
L1:PEM-CS_ACC_BSC1_ITMY_Y_DQ	23.9	1.4e+01	1.1e-20	Upper Limit	1.5e-19	1.3e-19	1.21
L1:PEM-CS_ACC_HAM2_PRM_Y_DQ	34.6	3.9e+00	1.5e-20	Upper Limit	5.8e-20	5.0e-20	1.16
L1:PEM-CS_ACC_PSL_PERISCOPE_X_DQ	39.9	1.4e+00	3.4e-20	Upper Limit	4.6e-20	4.2e-20	1.10
L1:PEM-EY_ACC_EBAY_FLOOR_Z_DQ	44.2	1.3e+01	2.8e-21	Upper Limit	3.6e-20	3.5e-20	1.03

L1:PEM-CS\_MIC\_LVEA\_BS\_DQ 2019-05-10 01:00:00 - 1,241,485,218 (2:30:00)

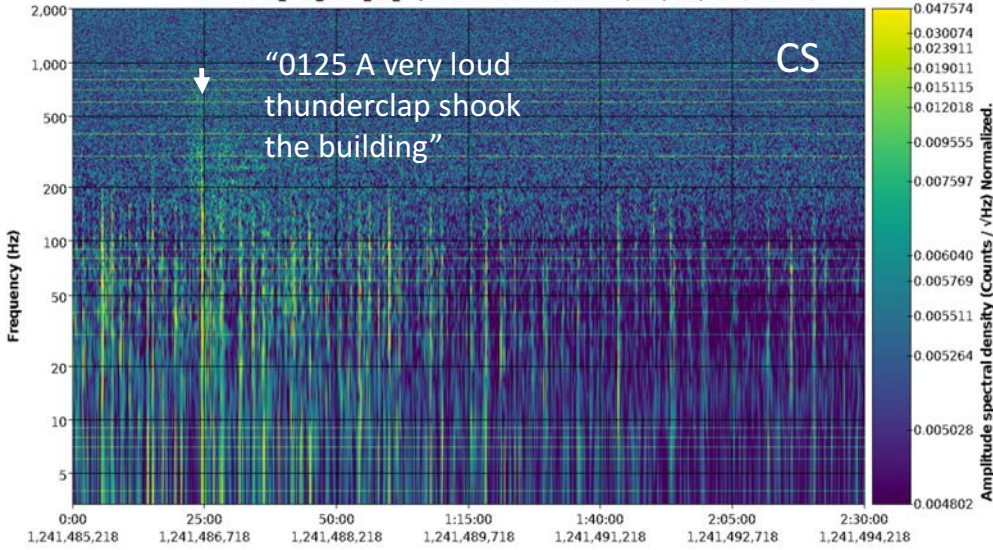

Fs=16,384Hz, sec/fft = 0.30, overlap = 0.50, fft length=4,915, #-FFT = 59990, bw = 3, in samples = 147,456K, up = 1.00, low = 0.20

L1:PEM-EX\_MIC\_VEA\_PLUSX\_DQ 2019-05-10 01:00:00 - 1,241,485,218 (2:30:00)

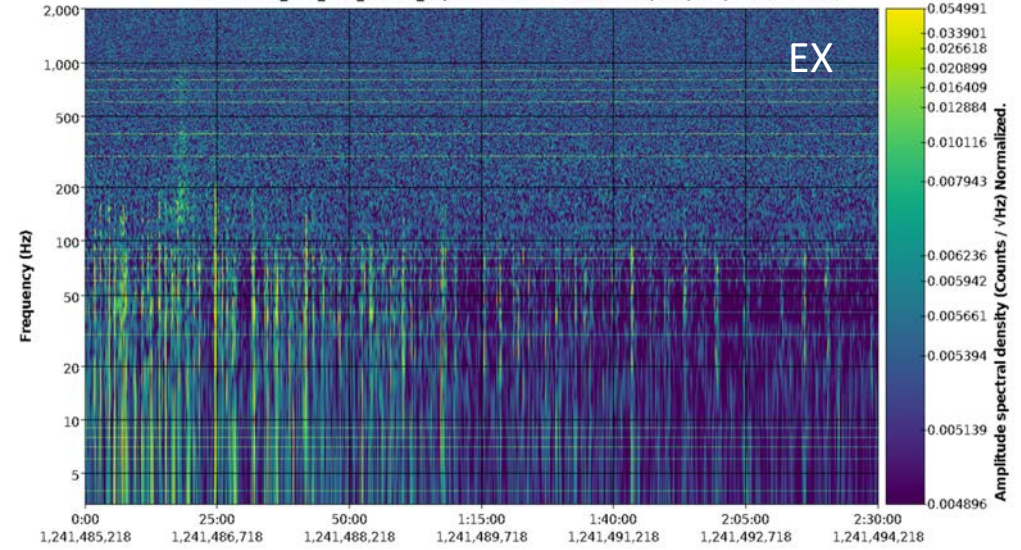

Fs=16,384Hz, sec/fft = 0.30, overlap = 0.50, fft length=4,915, #-FFT = 59990, bw = 3, in samples = 147,456K, up = 1.00, low = 0.20

L1:PEM-EY\_MIC\_VEA\_PLUSY\_DQ 2019-05-10 01:00:00 - 1,241,485,218 (2:30:00)

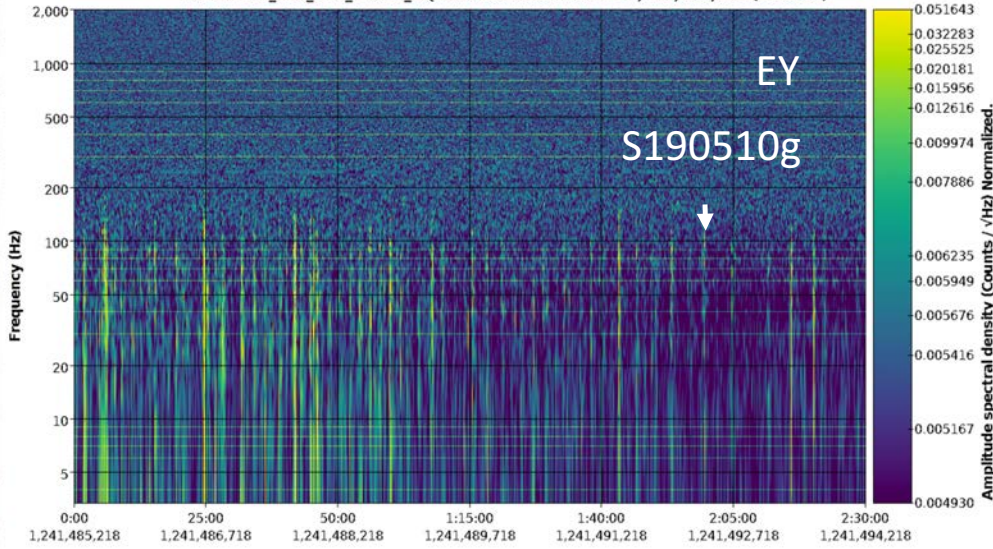

Fs=16,384Hz, sec/fft = 0.30, overlap = 0.50, fft length=4,915, #-FFT = 59990, bw = 3, in samples = 147,456K, up = 1.00, low = 0.20

L1:PEM-EY\_ACC\_BEAMTUBE\_MAN\_Y\_DQ 2019-05-10 01:00:00 - 1,241,485,218 (2:30:00)

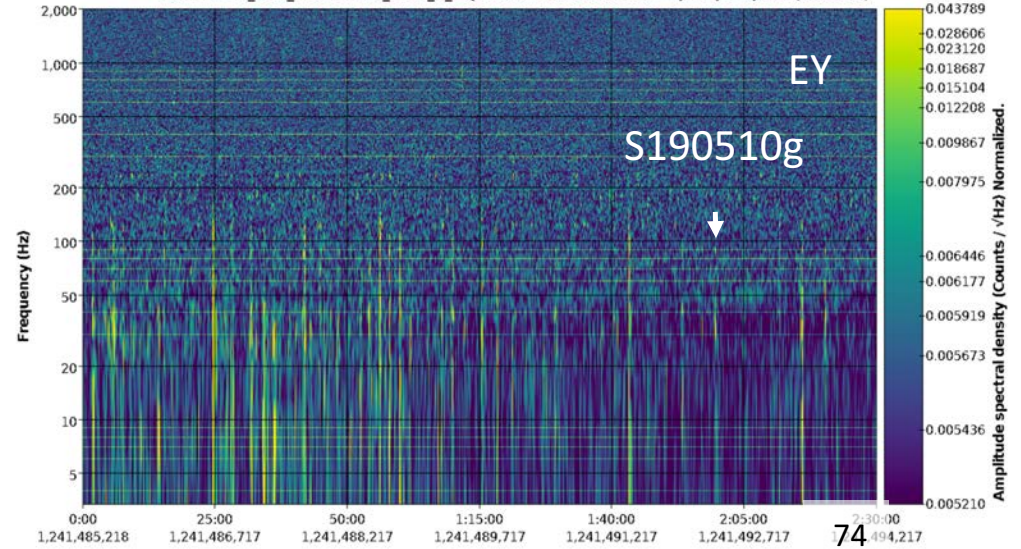

Fs=4,096Hz, sec/fft = 0.30, overlap = 0.50, fft length=1,228, #-FFT = 59999, bw = 3, in samples = 36,864K, up = 1.00, low = 0.20

L1:OAF-CAL\_DARM\_DQ 2019-05-10 02:50:00 - 1,241,491,818 (40:00)

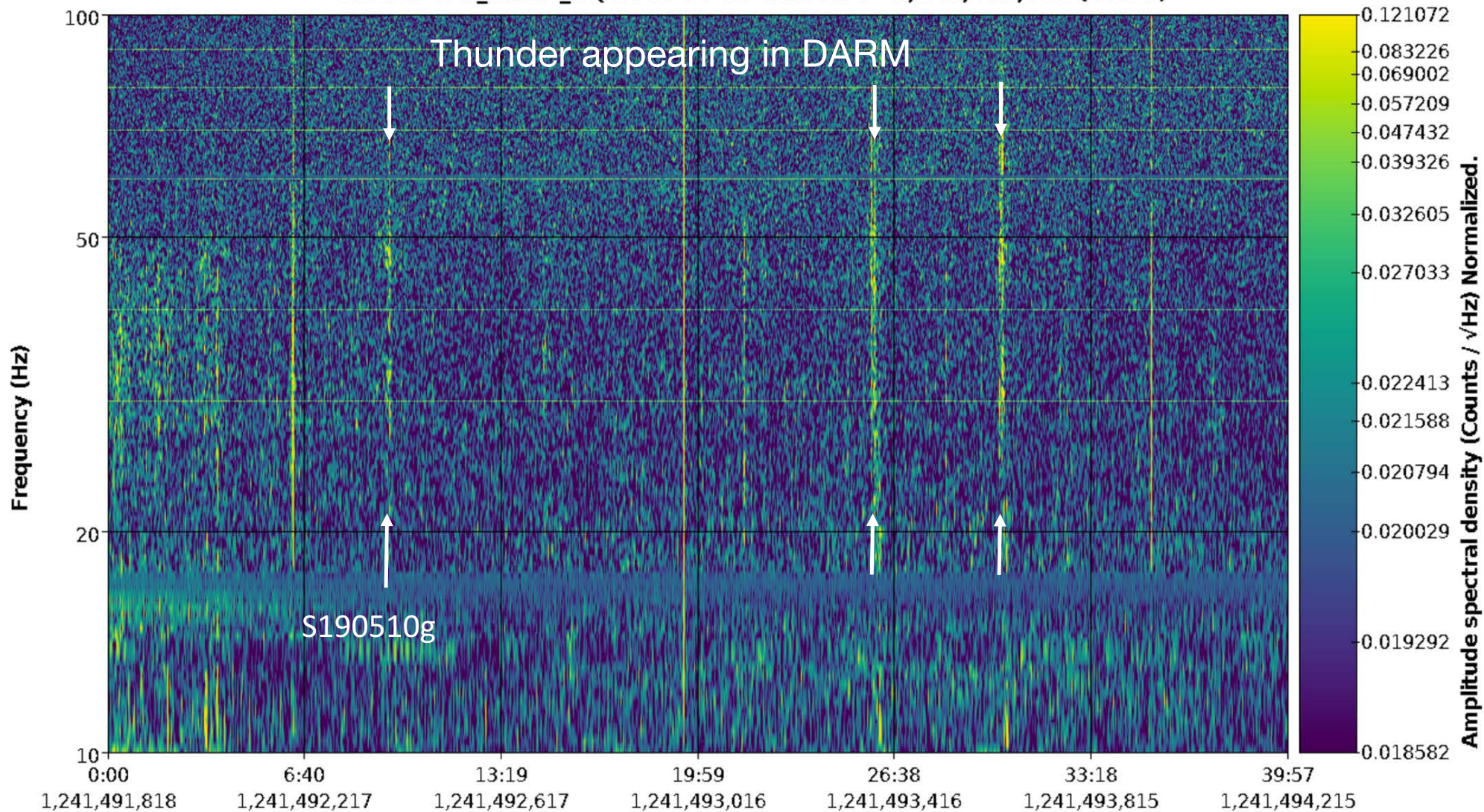

Fs=16,384Hz, sec/fft = 3.00, overlap = 0.90, fft length=49,152, #-FFT = 7990, bw = 0.33, in samples = 39,322K, up = 1.00, low = 0.20

L1:OAF-CAL\_DARM\_DQ 2019-05-10 02:50:00 - 1,241,491,818 (40:00)

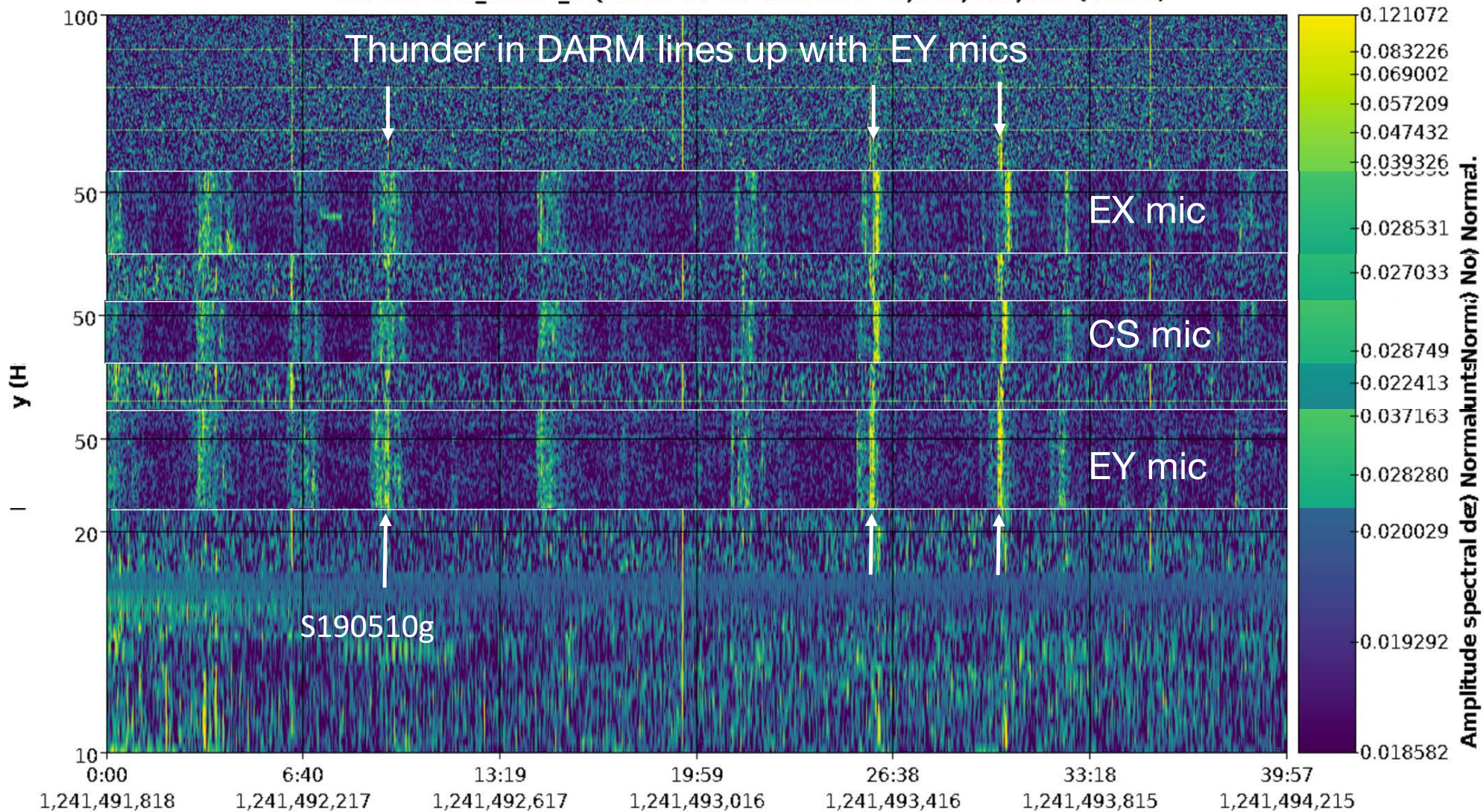

Fs=16,384Hz, sec/fft = 3.00, overlap = 0.90, fft length=49,152, #-FFT = 7990, bw = 0.33, in samples = 39,322K, up = 1.00, low = 0.20

## H1 PEM (DetChar)

[Link](#) 

robert.schofield@LIGO.ORG - posted 22:07, Wednesday 01 May 2019 (48912)

### HVAC noise in DARM roughly consistent with prediction for septum from PEM injections

Philippe, Sharan, Kara, Anamaria, Robert

The HVAC reduces our range by 3 or 4 MPc (<https://alog.ligo-wa.caltech.edu/aLOG/index.php?callRep=48649> ). Shutting down the various stations showed that the corner station is the worst culprit but there also appears to be some coupling at EX. Figure 1 shows that the HVAC is affecting DARM in the 30-90 Hz region. The lower plot in Figure 1 shows that, at the corner station, the HVAC increases ground and septum motion above a few Hz. This is in the frequency band that we can shake with the big shaker, so we would hope to be able to reproduce the HVAC effect, though, of course, local shaking would differ some from the more global shaking produced by the HVAC.

A preview of the LVEA vibration coupling summary from the recent PEM injection program suggests that the strongest coupling site in the 30-90 Hz band is in the HAM5/6 area (Figure 2a). Impulse injections narrow the coupling site down to the septum (<https://alog.ligo-wa.caltech.edu/aLOG/index.php?callRep=48886> ). Figure 2b suggests that the noise from the motion of the septum when the HVAC is on would be a factor of about 3 below the DARM floor. This would be enough to produce the several percent change in DARM when the HVAC was turned off and the septum motion was reduced by a factor of 1.5 to 2.

#### Non-image files attached to this report

 [Figure1-HVAC-effect-DARM-and-sensors.pdf](#)

 [Figure2-Vibration-contribution-estimate.pdf](#)



Trend from 19-04-20-15-19-01 to 19-04-20-19-19-00

Ch 5: H1:PEM-CS\_SEIS\_LVEA\_VERTEX\_Z\_BLRMS\_10HZ30

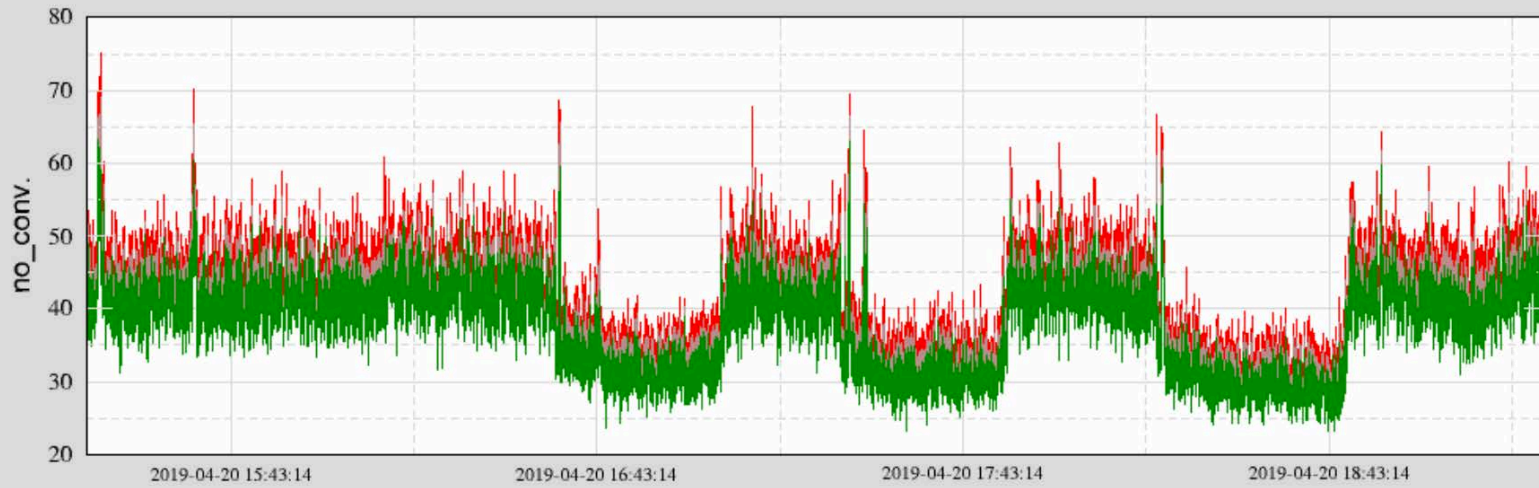

Ch 1: H1:CDS-SENSMON\_CAL\_SNSW\_EFFECTIVE\_RANGE\_MPC

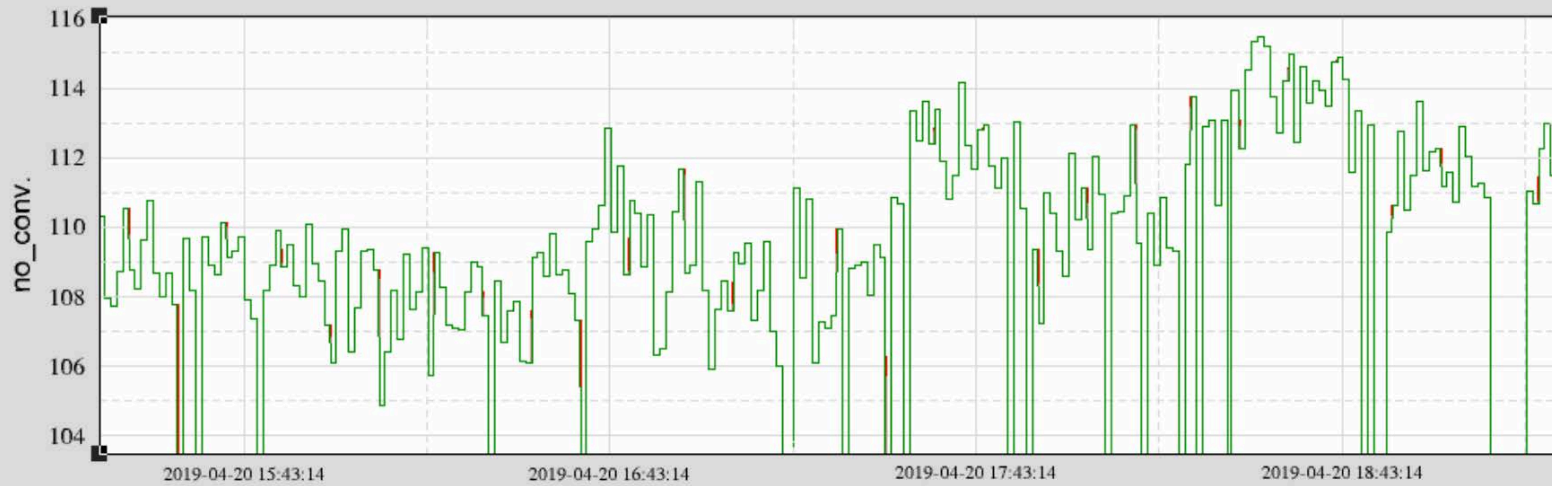

Power spectrum

Both plots, Red: HVAC on, Blue: HVAC off

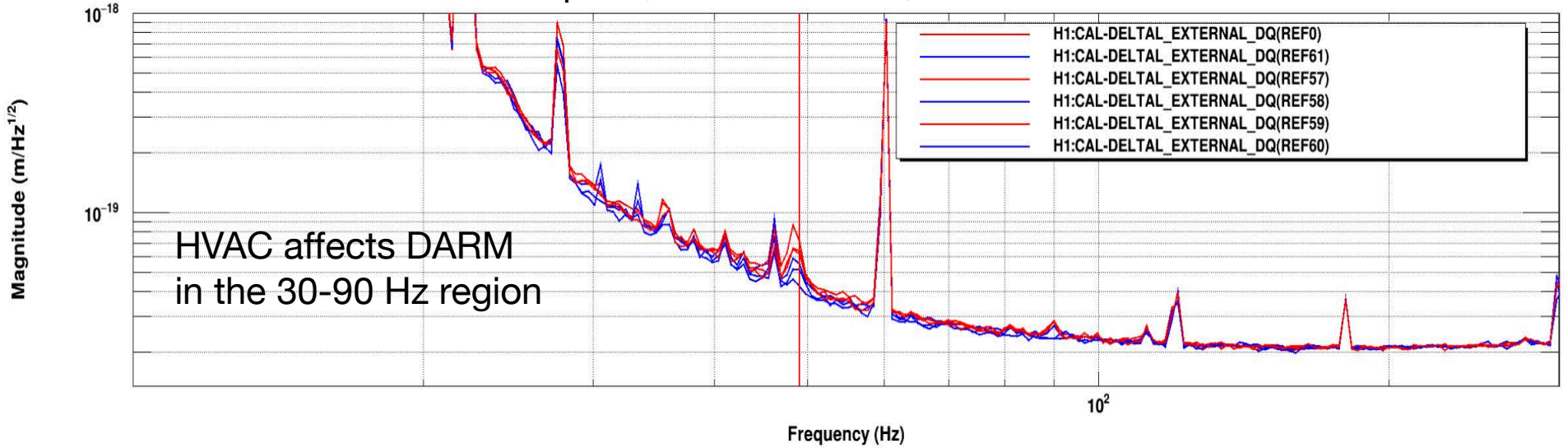

\*T0=20/04/2019 17:11:00

Avg=100/Bin=5L

BW=0.187499

Power spectrum

HVAC affects seismometer and accelerometer signals above 5 Hz

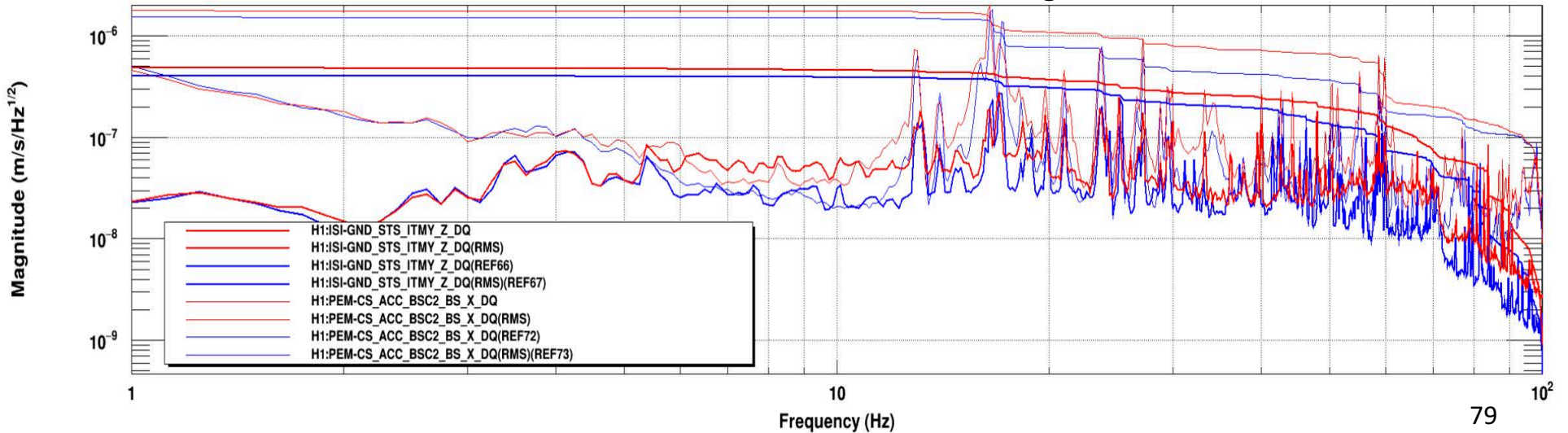

\*T0=20/04/2019 17:11:00

Ava=100

BW=0.1875

Figure 2b

### H1:PEM-CS ACC HAM6VAC SEPTUM Y Highest Estimated ambient from all injections

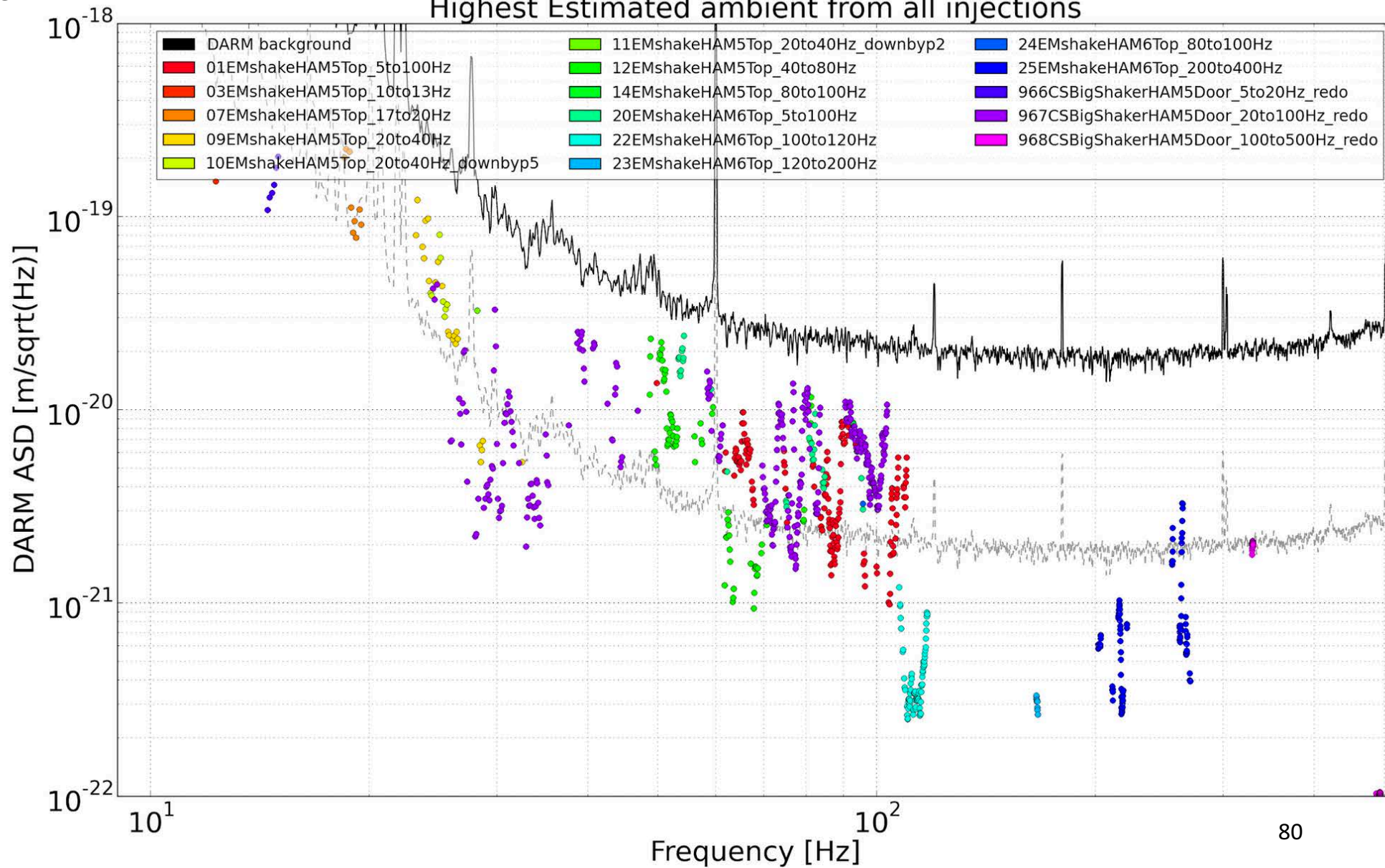



## H1 AOS

Link 

sharan.banagiri@LIGO.ORG - posted 09:37, Tuesday 28 May 2019 (49495)

### PEM with Rain using HAM6 Vac accelerometer

S Banagiri, P Covas, R Schofield

We looked into the adhoc rain pem injection in more detail ( [mentioned here before](#) ), using transfer function measurements by [Philippe Nguyen with the HAM6 Vac accelerometer](#). Quantitatively, these predictions show that we somewhat underestimate the noise in DARM during rain using only the HAM6 accelerometer prediction. I attach a plot of a DARM background ASD and DARM during rain plotted in black and red respectively using about 5 minutes of data. Also plotted are the predictions of DARM noise in the 30 - 100 Hz band using the HAM6 Vac accelerometer. The blue curve is the ambient noise prediction and the green curve is the prediction during rain.

### Images attached to this report

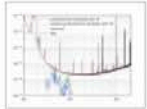

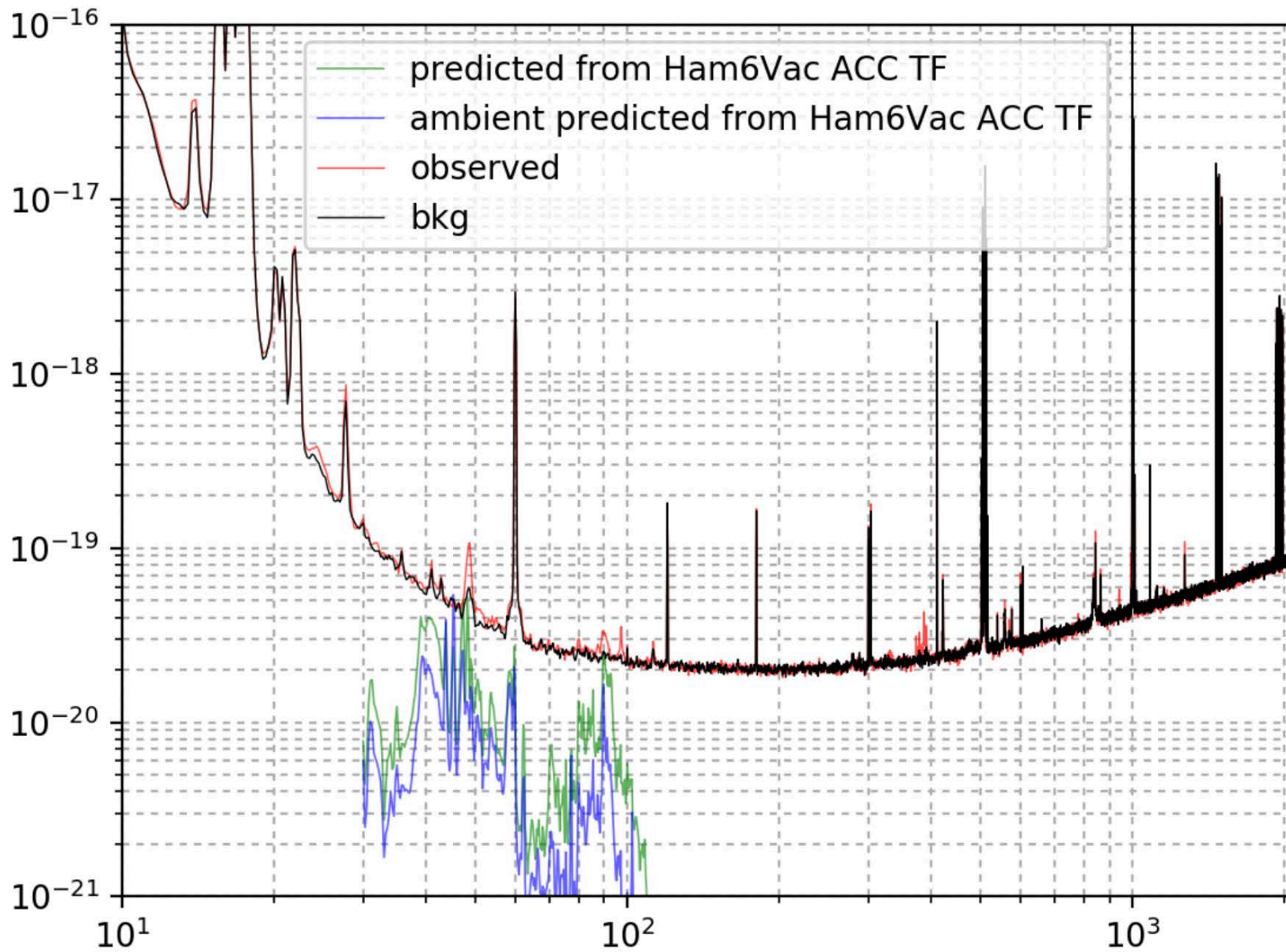

## Introduction

### A. Vibration coupling, worst sites

- 1) LLO EX transmission monitor
- 2) Next worst sites at LLO are EY and HAM5/6 and, at LHO, HAM5/6 and the PSL
- 3) At both sites, HAM5/6 coupling is likely at the septum
- 4) EY coupling at LLO is likely in the manifold, at LHO, it may in the ETMY chamber
- 5) HAM5/6 coupling at the septum window?

*Other beam spots on LLO HAM6*

*OMC REFL beam not the cause of the main HAM5/6 scattering*

*HAM6 witness search at LLO*

- 6) IO jitter coupling at both sites
- 7) Comparison of EY and EX in-lock photos
- 8) Shaker injections at EY produce noise similar to some anthropogenic noise
- 9) Other vibration coupling

*Beamtube shaking*

*Coupling at LHO BS chamber and at the reduction flanges by the optical lever*

*48 Hz peak at LHO*

*Reduction of 58 Hz chiller peak at LHO:*

- 10) Vibration coupling not seen (at least 10 below DARM)
- 11) Coupling estimates from PEM injections correctly predict environmental coupling
  - LLO DARM glitch near S190510g is correctly predicted from PEM injection coupling functions.*
  - Range reduction from LHO HVAC is roughly predicted from estimates for HAM5/6.*
  - Range reduction from rain at LHO is roughly consistent with PEM coupling functions*
  - Range reduction from wind at LHO is roughly consistent with PEM coupling functions.*

### B. Magnetic Coupling

### C. RF Coupling

### D. Site activities

# L1 Magnetic - Estimated Ambient

Highest coupling factor at each frequency across all channels)

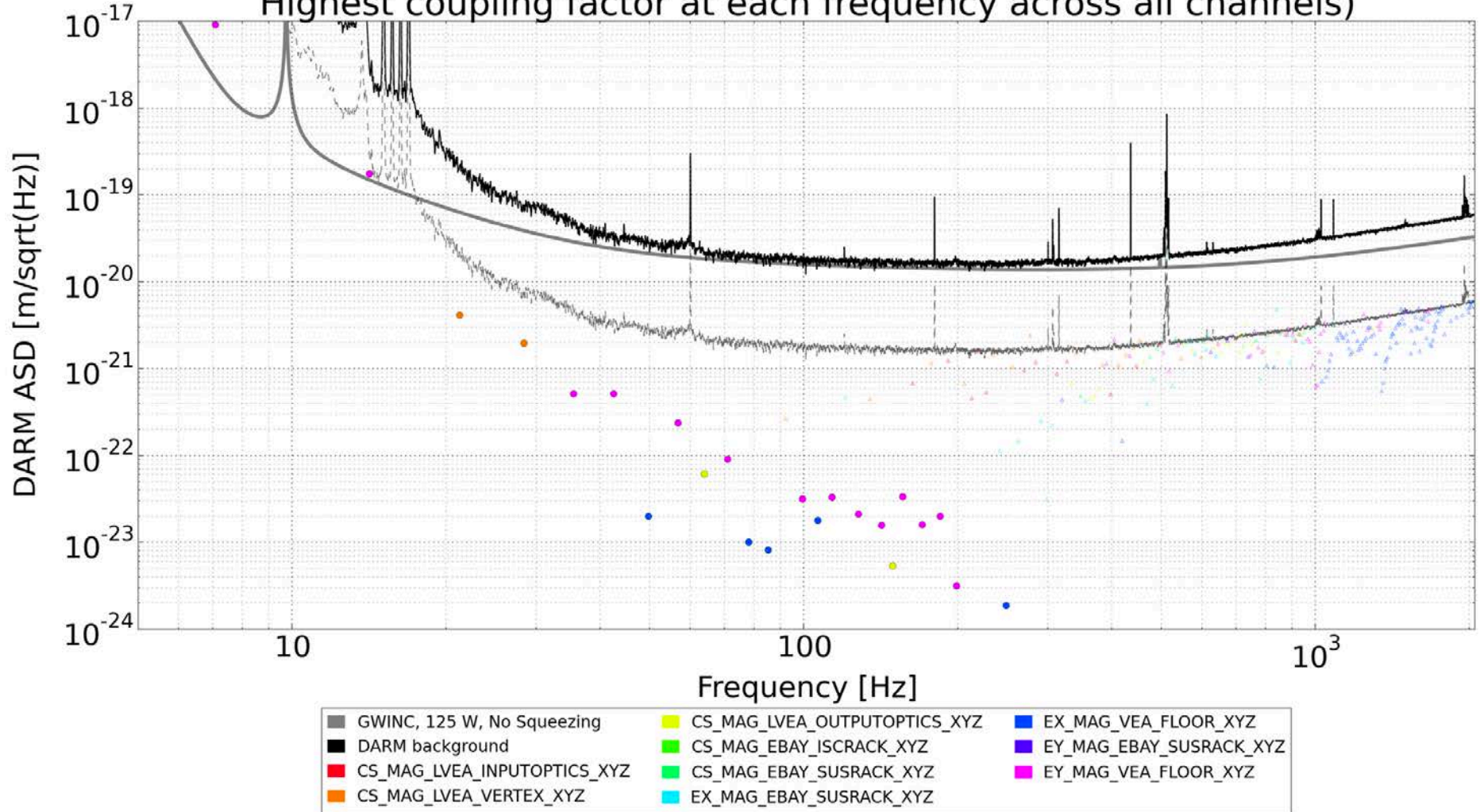

Ambient estimates are made by multiplying coupling factors by injection-free sensor levels. CIRCLES indicate estimates from measured coupling factors, i.e. where the injection signal was seen in the sensor and in DARM. TRIANGLES represent upper limit coupling factors, i.e. where a signal was seen in the sensor but not in DARM. For some channels, at certain frequencies the ambient estimates are upper limits because the ambient level is below the sensor noise floor.

## H1 Magnetic - Estimated Ambient Highest coupling factor at each frequency across all channels)

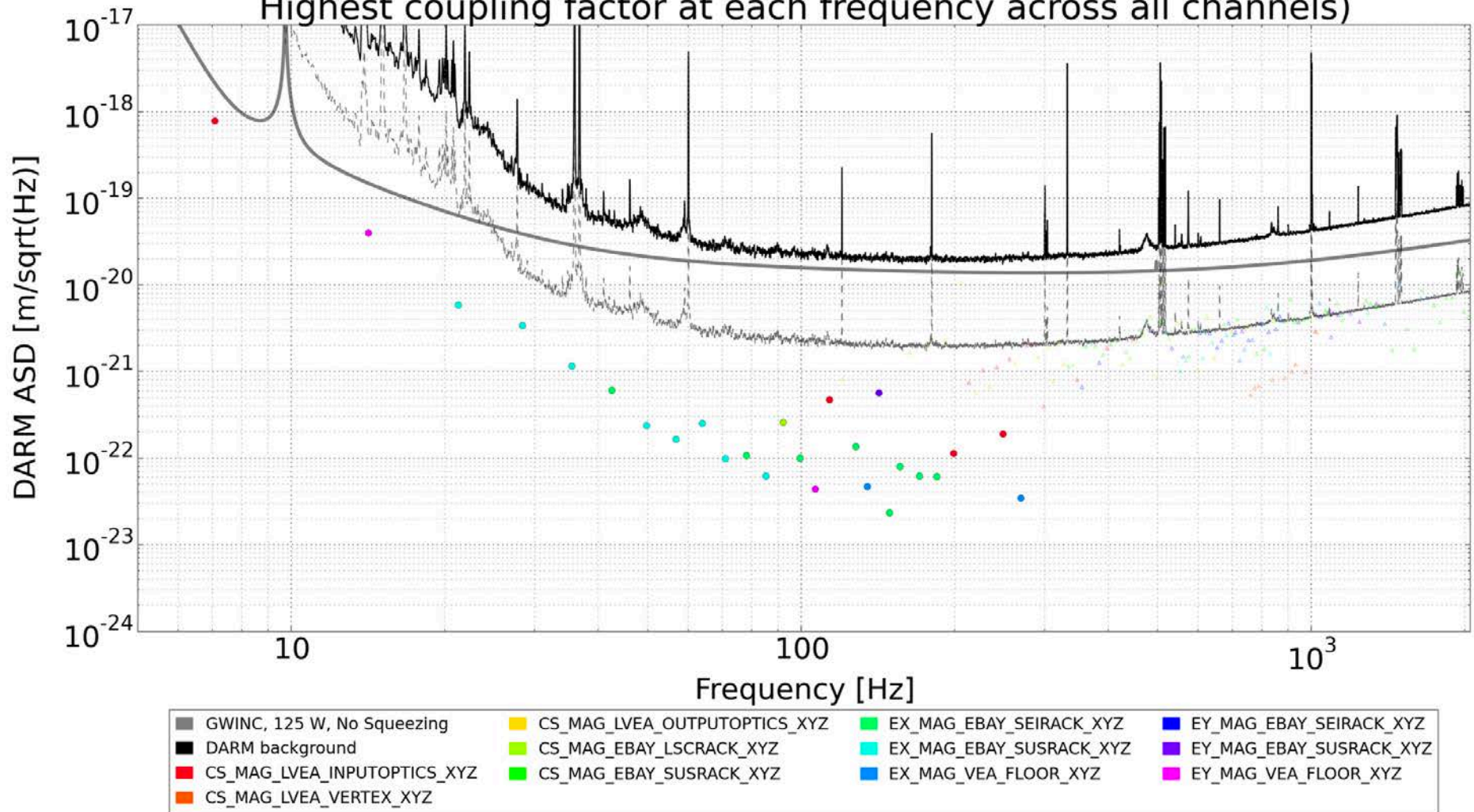

Ambient estimates are made by multiplying coupling factors by injection-free sensor levels. CIRCLES indicate estimates from measured coupling factors, i.e. where the injection signal was seen in the sensor and in DARM. TRIANGLES represent upper limit coupling factors, i.e. where a signal was seen in the sensor but not in DARM. For some channels, at certain frequencies the ambient estimates are upper limits because the ambient level is below the sensor noise floor.

a

### Coupling of big-coil magnetic injection to DARM

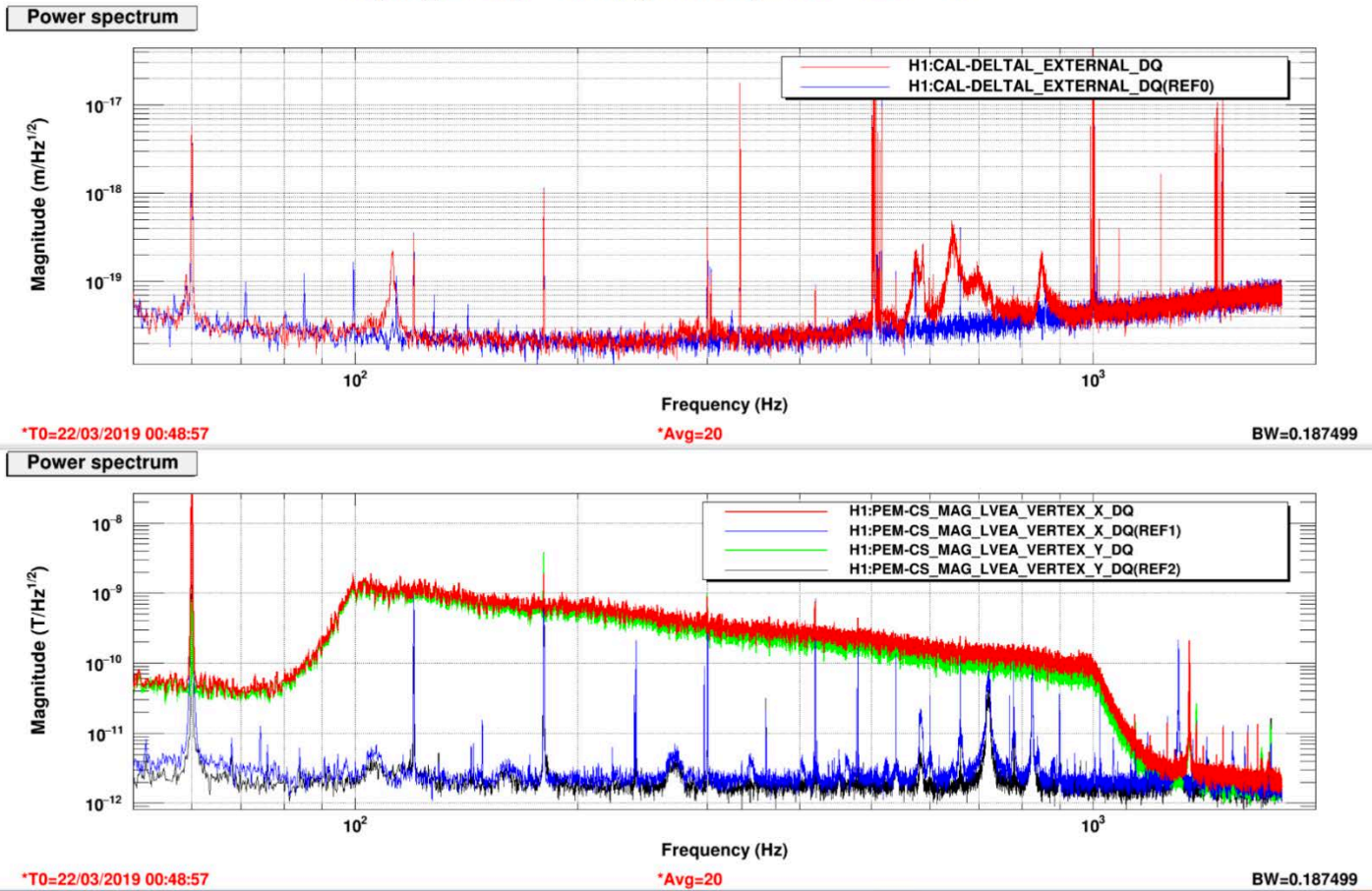

## Introduction

### A. Vibration coupling, worst sites

- 1) LLO EX transmission monitor
- 2) Next worst sites at LLO are EY and HAM5/6 and, at LHO, HAM5/6 and the PSL
- 3) At both sites, HAM5/6 coupling is likely at the septum
- 4) EY coupling at LLO is likely in the manifold, at LHO, it may in the ETMY chamber
- 5) HAM5/6 coupling at the septum window?

*Other beam spots on LLO HAM6*

*OMC REFL beam not the cause of the main HAM5/6 scattering*

*HAM6 witness search at LLO*

- 6) IO jitter coupling at both sites
- 7) Comparison of EY and EX in-lock photos
- 8) Shaker injections at EY produce noise similar to some anthropogenic noise
- 9) Other vibration coupling

*Beamtube shaking*

*Coupling at LHO BS chamber and at the reduction flanges by the optical lever*

*48 Hz peak at LHO*

*Reduction of 58 Hz chiller peak at LHO:*

- 10) Vibration coupling not seen (at least 10 below DARM)
- 11) Coupling estimates from PEM injections correctly predict environmental coupling
  - LLO DARM glitch near S190510g is correctly predicted from PEM injection coupling functions.*
  - Range reduction from LHO HVAC is roughly predicted from estimates for HAM5/6.*
  - Range reduction from rain at LHO is roughly consistent with PEM coupling functions*
  - Range reduction from wind at LHO is roughly consistent with PEM coupling functions.*

### B. Magnetic Coupling

### C. RF Coupling

### D. Site activities

# LHO

9 MHz

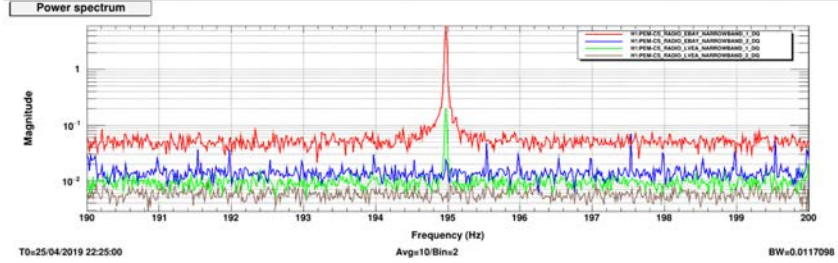
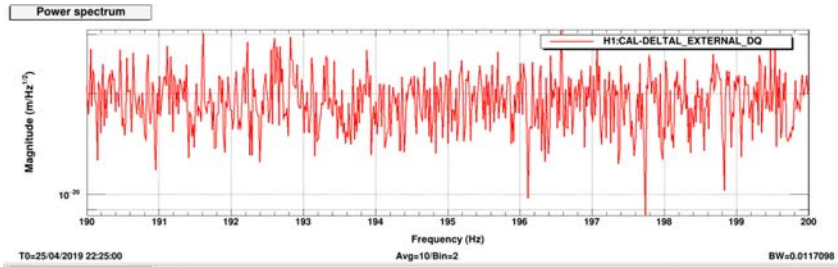

45 MHz

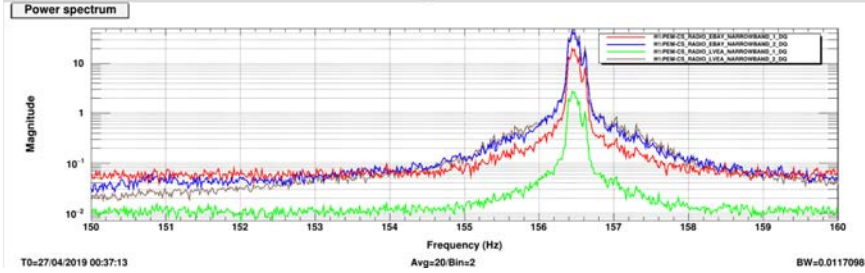
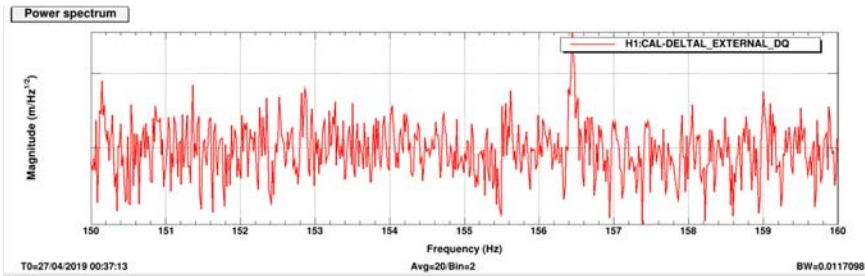

# LLO

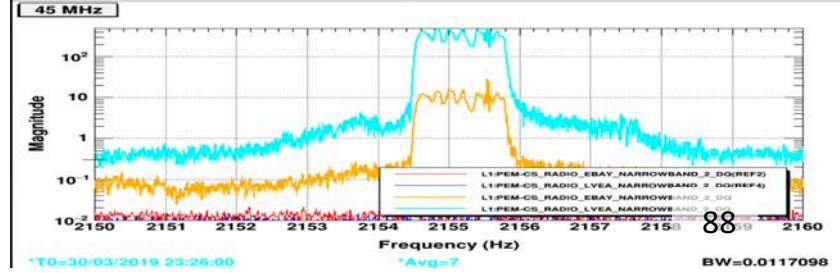
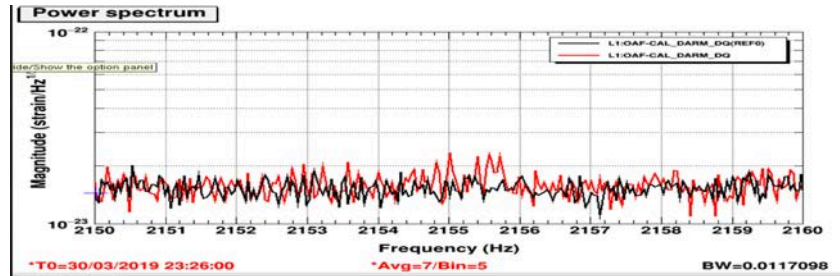
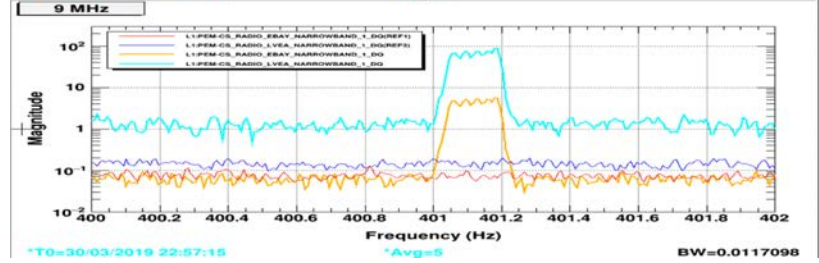
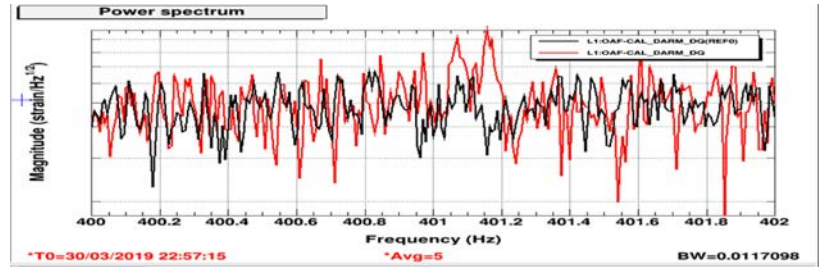



## Introduction

### A. Vibration coupling, worst sites

- 1) LLO EX transmission monitor
- 2) Next worst sites at LLO are EY and HAM5/6 and, at LHO, HAM5/6 and the PSL
- 3) At both sites, HAM5/6 coupling is likely at the septum
- 4) EY coupling at LLO is likely in the manifold, at LHO, it may in the ETMY chamber
- 5) HAM5/6 coupling at the septum window?

*Other beam spots on LLO HAM6*

*OMC REFL beam not the cause of the main HAM5/6 scattering*

*HAM6 witness search at LLO*

- 6) IO jitter coupling at both sites
- 7) Comparison of EY and EX in-lock photos
- 8) Shaker injections at EY produce noise similar to some anthropogenic noise
- 9) Other vibration coupling

*Beamtube shaking*

*Coupling at LHO BS chamber and at the reduction flanges by the optical lever*

*48 Hz peak at LHO*

*Reduction of 58 Hz chiller peak at LHO:*

- 10) Vibration coupling not seen (at least 10 below DARM)
- 11) Coupling estimates from PEM injections correctly predict environmental coupling
  - LLO DARM glitch near S190510g is correctly predicted from PEM injection coupling functions.*
  - Range reduction from LHO HVAC is roughly predicted from estimates for HAM5/6.*
  - Range reduction from rain at LHO is roughly consistent with PEM coupling functions*
  - Range reduction from wind at LHO is roughly consistent with PEM coupling functions.*

### B. Magnetic Coupling

### C. RF Coupling

### D. Site activities

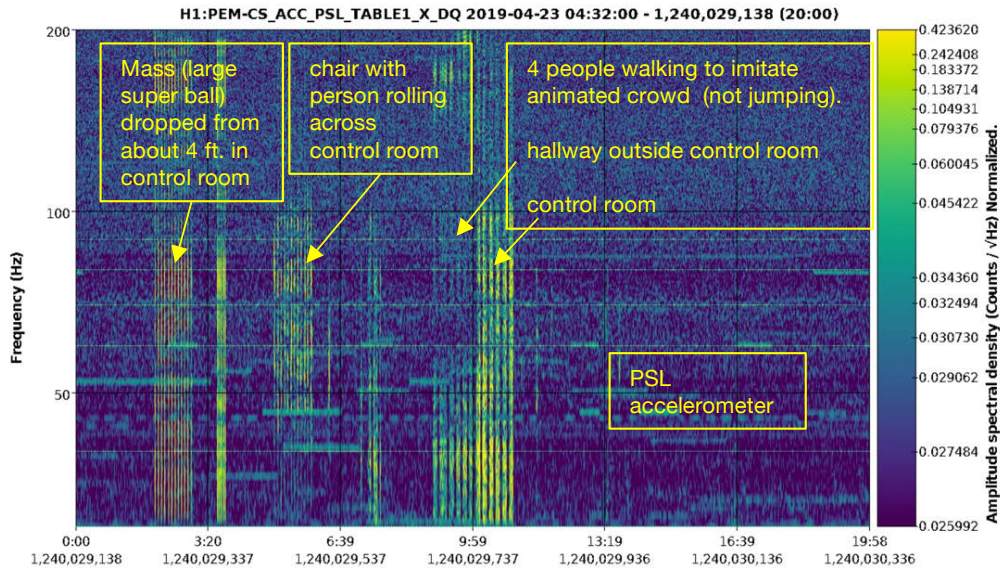

Fs=4,096Hz, sec/fft = 2.00, overlap = 0.90, fft length=8,192, #-FFT = 5986, bw = 0.50, in samples = 4,915K, up = 1.00, low = 0.20

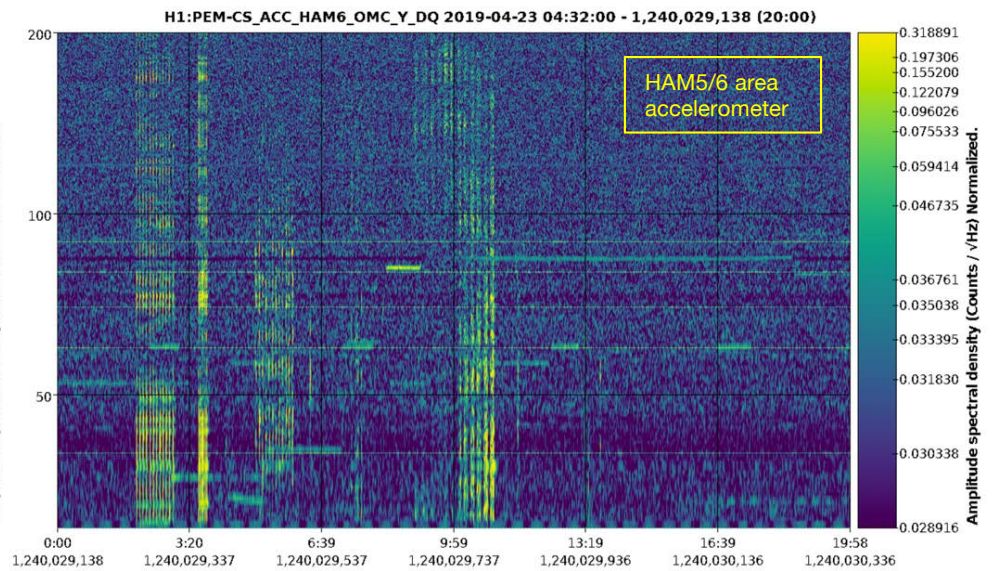

Fs=4,096Hz, sec/fft = 2.00, overlap = 0.90, fft length=8,192, #-FFT = 5986, bw = 0.50, in samples = 4,915K, up = 1.00, low = 0.20

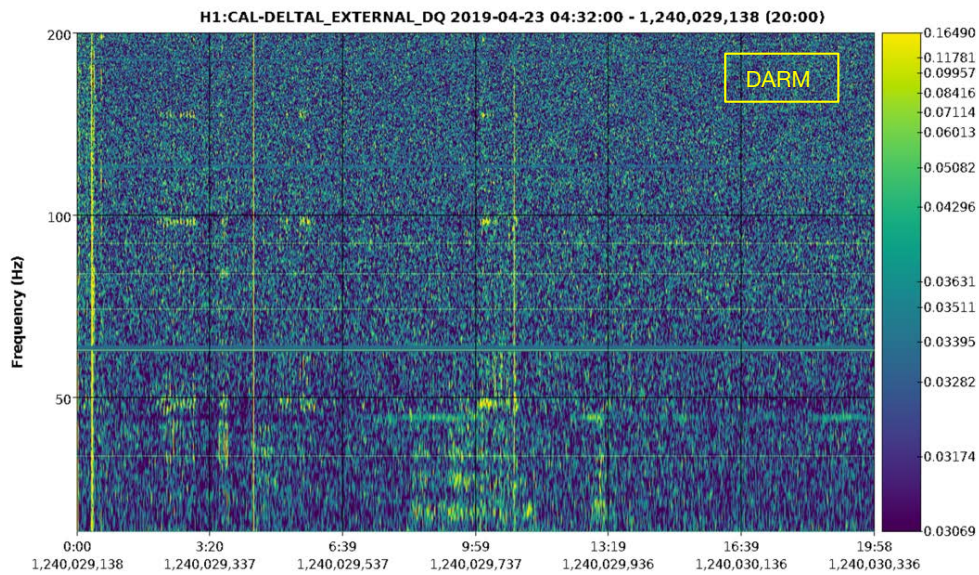

Fs=16,384Hz, sec/fft = 2.00, overlap = 0.90, fft length=32,768, #-FFT = 5991, bw = 0.50, in samples = 19,661K, up = 1.00, low = 0.20

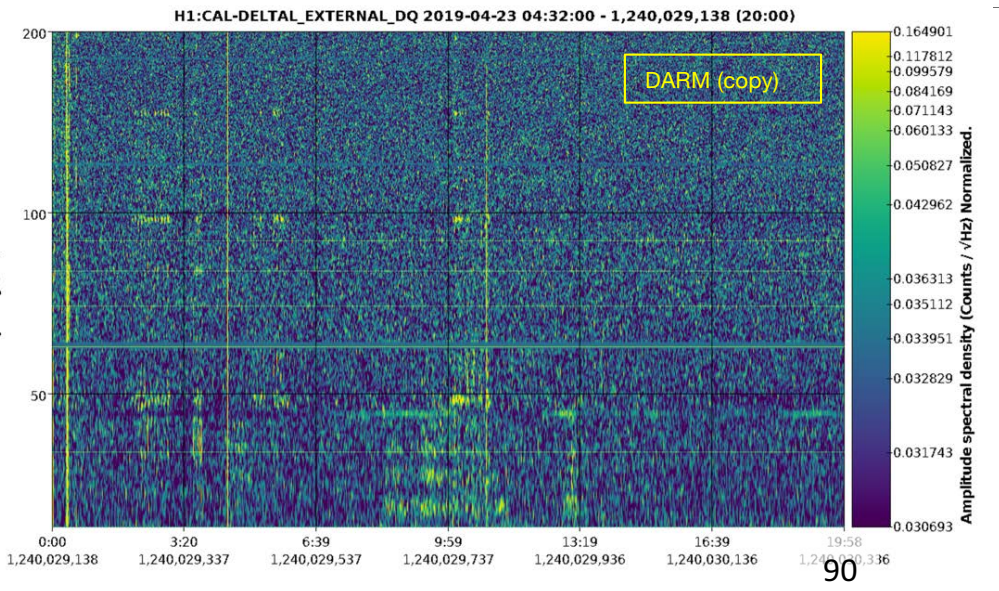

Fs=16,384Hz, sec/fft = 2.00, overlap = 0.90, fft length=32,768, #-FFT = 5991, bw = 0.50, in samples = 19,661K, up = 1.00, low = 0.20

# Pre-O3 PEM injections

Philippe Nguyen, Sharan Banagiri, Corey Austin, Kara Merfeld  
Anamaria Effler, Robert Schofield

