

NOTES CONTINUED:

⑤ SCRIBE, ENGRAVE (A VIBRATORY TOOL MAY BE USED), LASER MARK OR MECHANICALLY STAMP (NO INKS OR DYES) DRAWING PART NUMBER, REVISION (AND VARIANT OR TYPE IF APPLICABLE) ON NOTED SURFACE OF PART FOLLOWED ON THE NEXT LINE WITH A THREE DIGIT SERIAL NUMBER. SERIAL NUMBERS START AT 001 FOR THE FIRST ARTICLE AND PROCEED CONSECUTIVELY. USE MINIMUM 0.12" HIGH CHARACTERS, UNLESS THE SIZE OF THE PART DICTATES SMALLER CHARACTERS. EXAMPLE: DXXXXXX-VY, TYPE-XX, S/N XXX

6. ALL PARTS SHALL BE MANUFACTURED IN ACCORDANCE WITH LIGO SPECIFICATION E0900364.

7. ALL MATERIAL IS TO BE VIRGIN MATERIAL (i.e. NO WELD REPAIRS, PLUGS OR RECYCLED MATERIAL). NO REPAIRS SHALL BE MADE UNLESS APPROVED IN ADVANCE, AND IN WRITING, BY LIGO LABORATORY. REFER TO LIGO-E0900364.

8. SURFACE FINISH TO BE AS-PROCESSED FROM MILL/SUPPLIER, FREE FROM SCRATCHES OR GOUGES.

⑨ FINISH: PLASMA SPRAY SHADED AREA WITH CHROMIUM OXIDE .008-.0010. REFER TO LIGO SPECIFICATION E1600325-v6.

⑩ MATERIAL: 304 SSSL SHEET, 14 Ga., 2B FINISH. THICKNESS IS DRIVING DIMENSIONS ON P/N D1600407 & D1600408. DATA FROM MEASURED THICKNESS OF MATERIAL SHOULD BE SUPPLIED TO LIGO PERSONNEL PRIOR TO FAB OF ALL PARTS.

-1 DETAIL

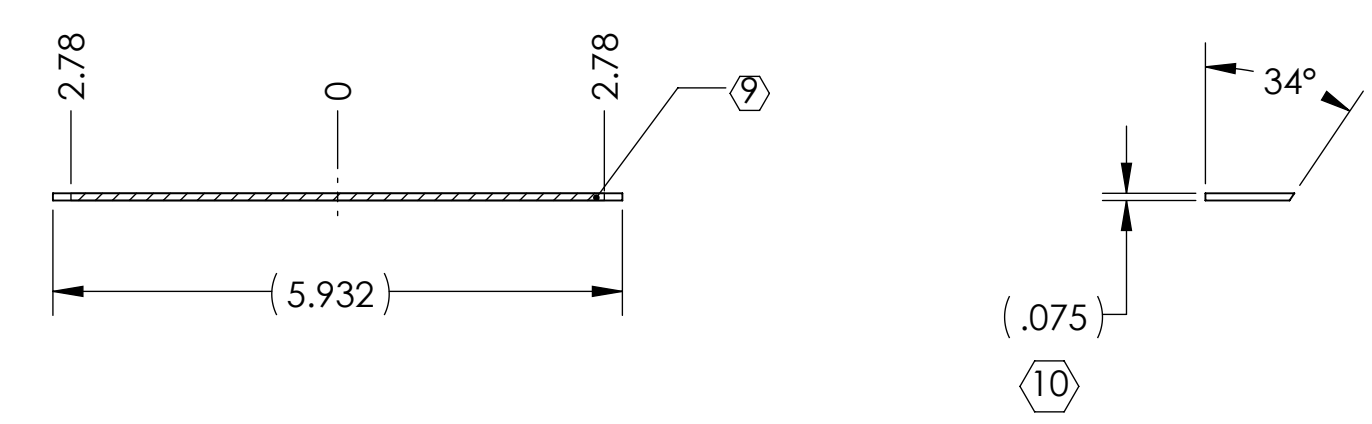
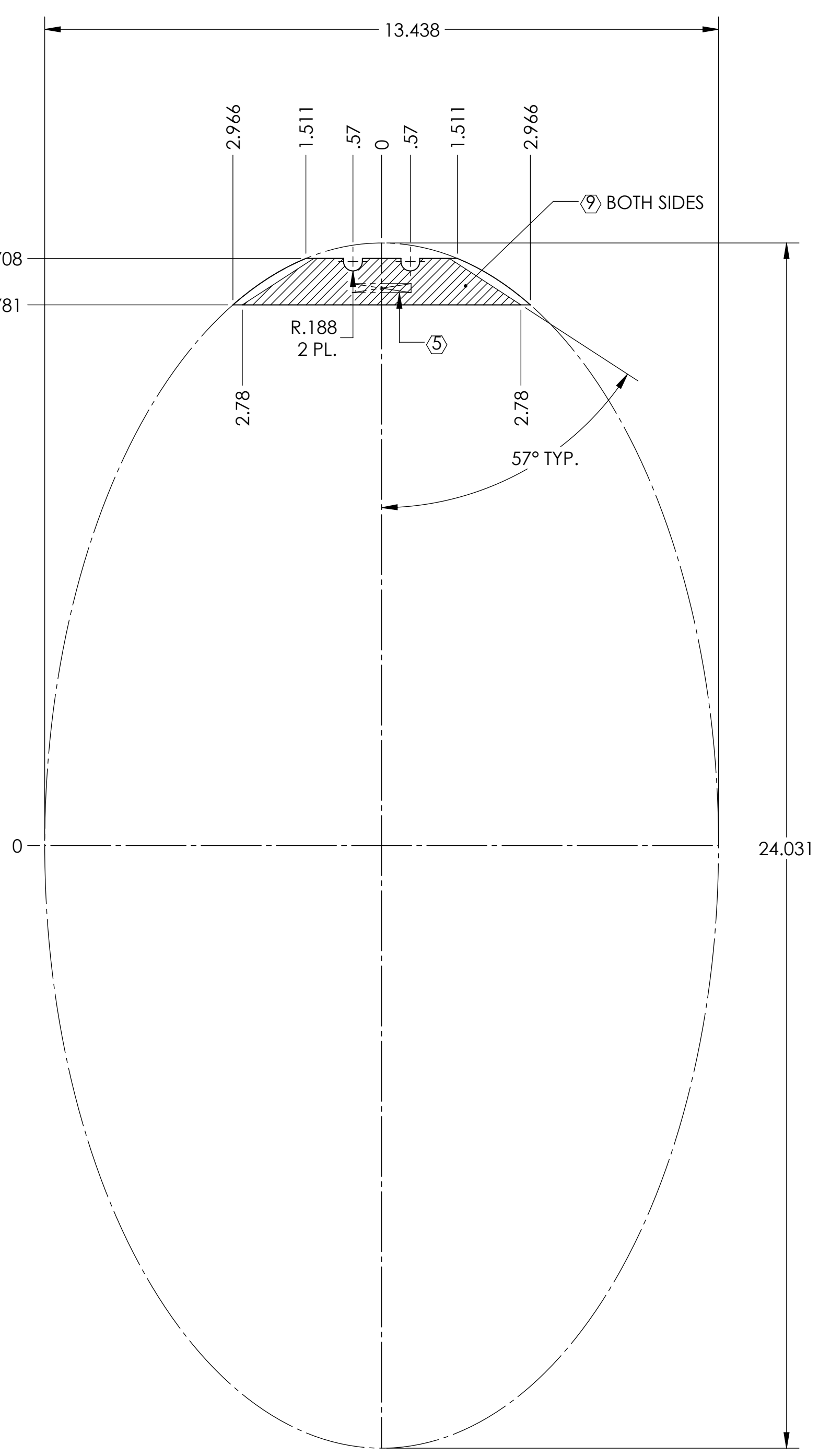

-2 DETAIL

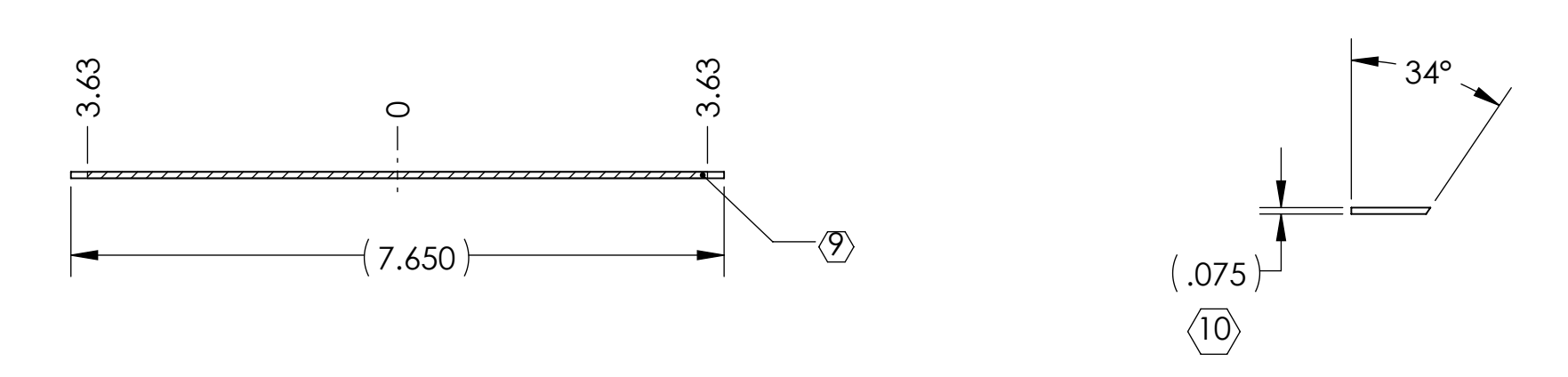
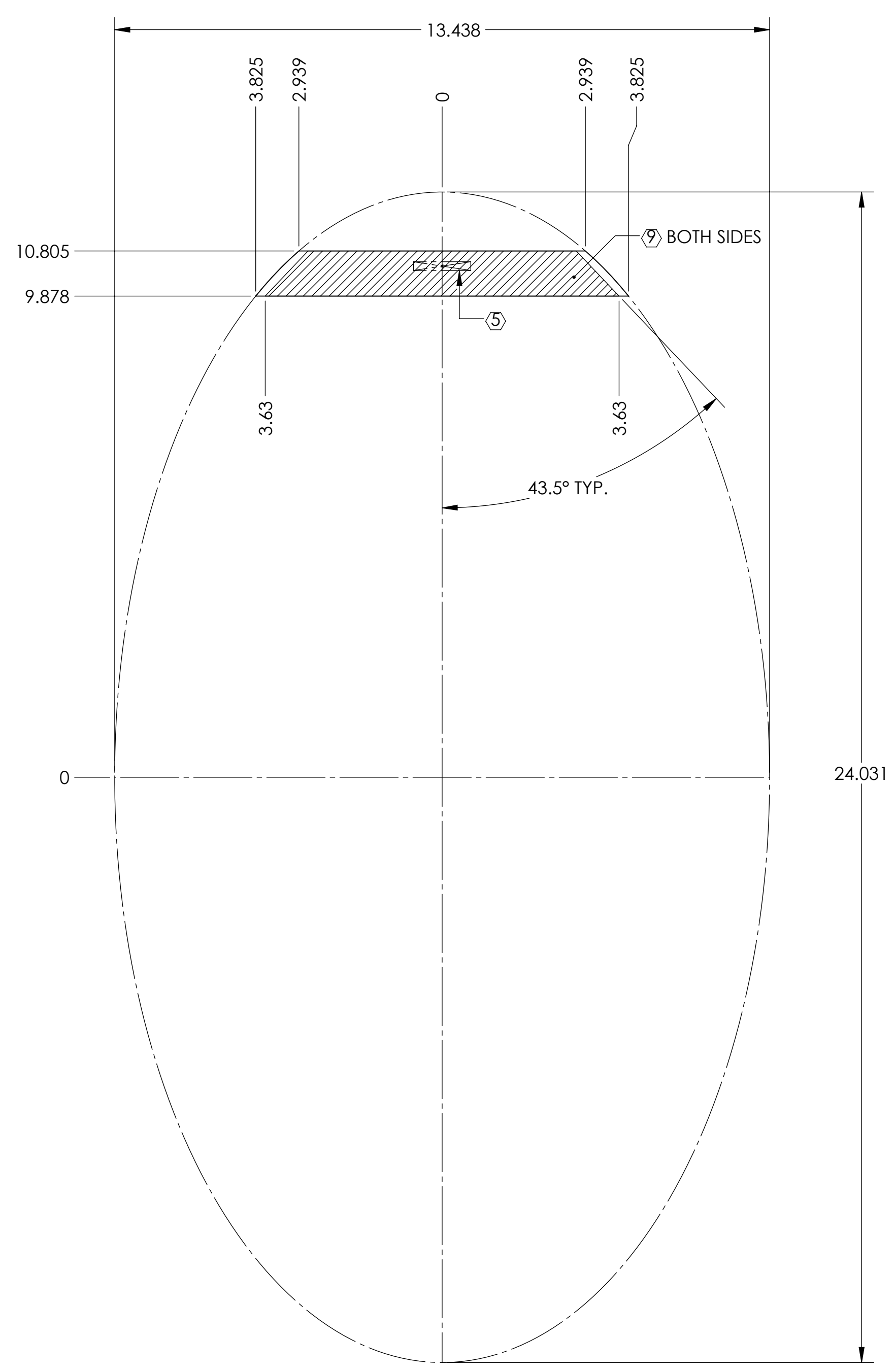

REV.	DATE	DCN #	DRAWING TREE #
v1	08 NOV 2016	-	-
v2	22 NOV 2016	E1600294-x0	-
-	-	-	-

NOTES AND TOLERANCES: (UNLESS OTHERWISE SPECIFIED)				CALIFORNIA INSTITUTE OF TECHNOLOGY LIGO MASSACHUSETTS INSTITUTE OF TECHNOLOGY		PART NAME	
1. INTERPRET DRAWING PER ASME Y14.5-1994. 2. REMOVE ALL SHARP EDGES, .005-.015, FOR MACHINED PARTS. ROUND ALL EDGES APPROXIMATELY R.02 FOR SHEET METAL PARTS. 3. DO NOT SCALE FROM DRAWING. 4. ALL MACHINING FLUIDS MUST BE FULLY SYNTHETIC, FULLY WATER SOLUBLE AND FREE OF SULFUR, SILICONE, AND CHLORINE.				SYSTEM ADVANCED LIGO		SUB-SYSTEM VE	
DIMENSIONS ARE IN INCHES TOLERANCES: .XX ± .01 .XXX ± .005 ANGULAR ± 0.5°				MATERIAL SEE NOTE ⑩		FINISH 63 μinch	
NEXT ASSY D1600409				DESIGNER E.SANCHEZ 09 SEP2015		SIZE DWG. NO. D 1600406	
REVISIONS v1 08 NOV 2016 v2 22 NOV 2016				CHECKER SEE DCC		REV. v2	
APPROVAL SEE DCC				SCALE: 1:2		PROJECTION:	
SHEET 1 OF 9				SHEET 1 OF 9		SHEET 1 OF 9	

D1600406.dwg, VE, Chevron UV Baffle, LOUVER, PART FDM REV: X.016, DRAWING FDM REV: X.009

-3 DETAIL

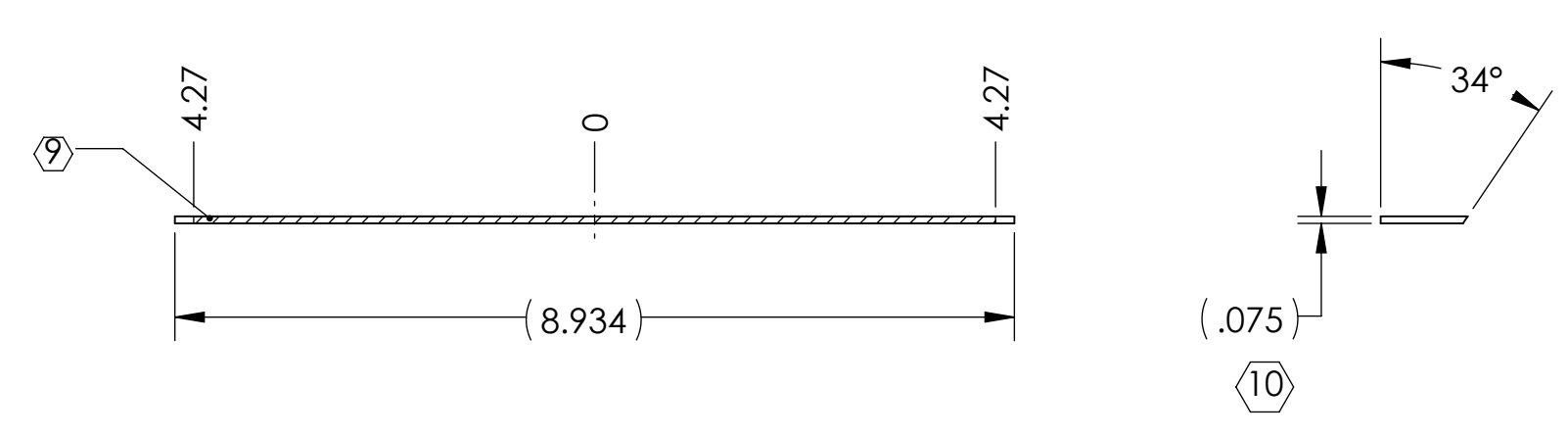
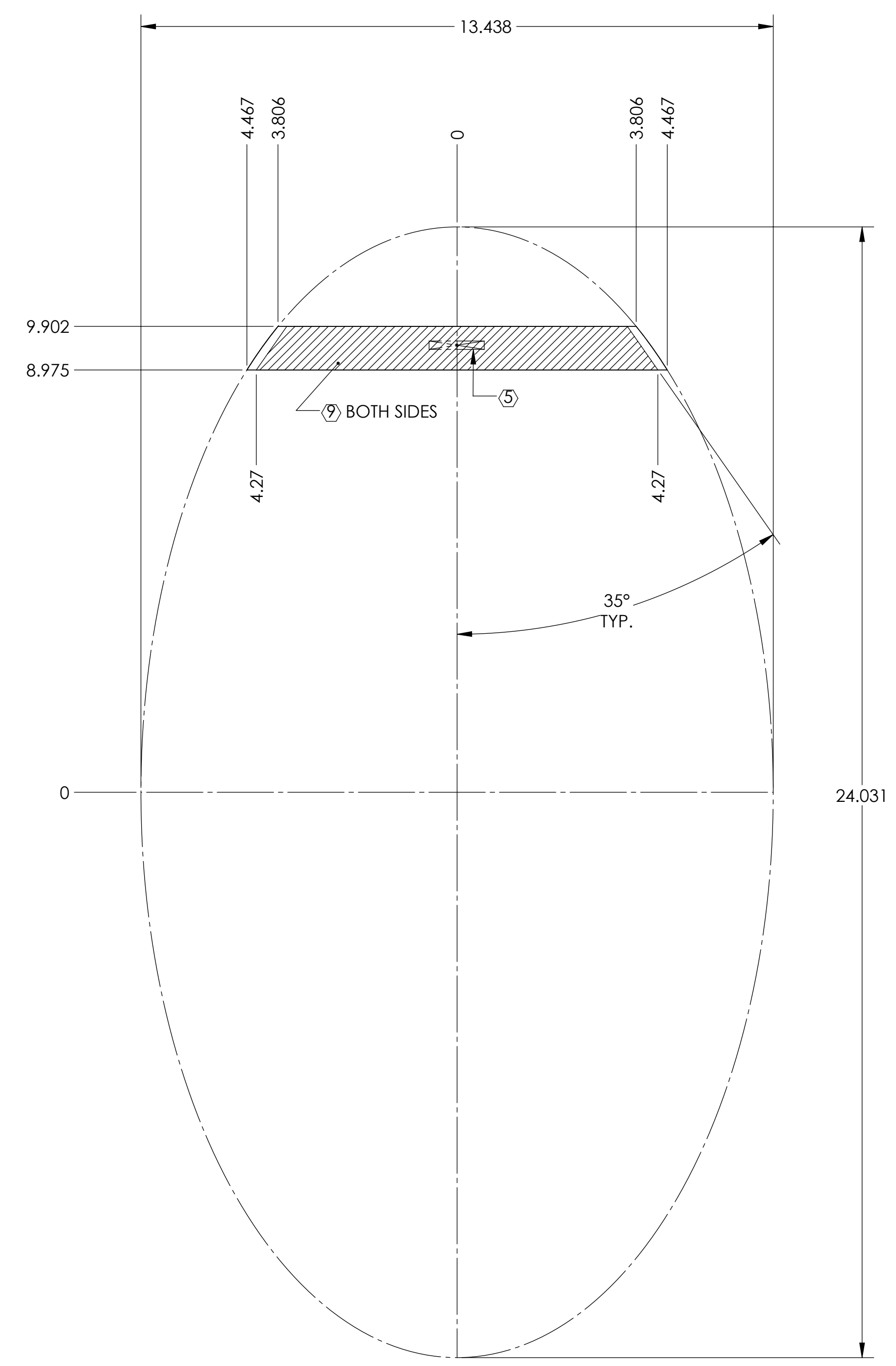

-4 DETAIL

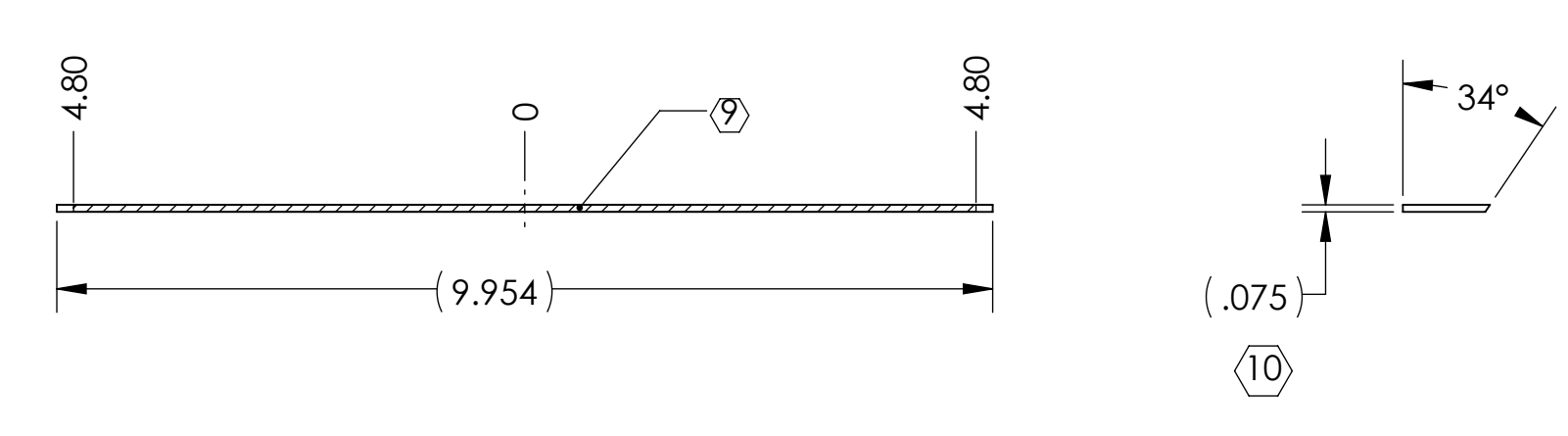
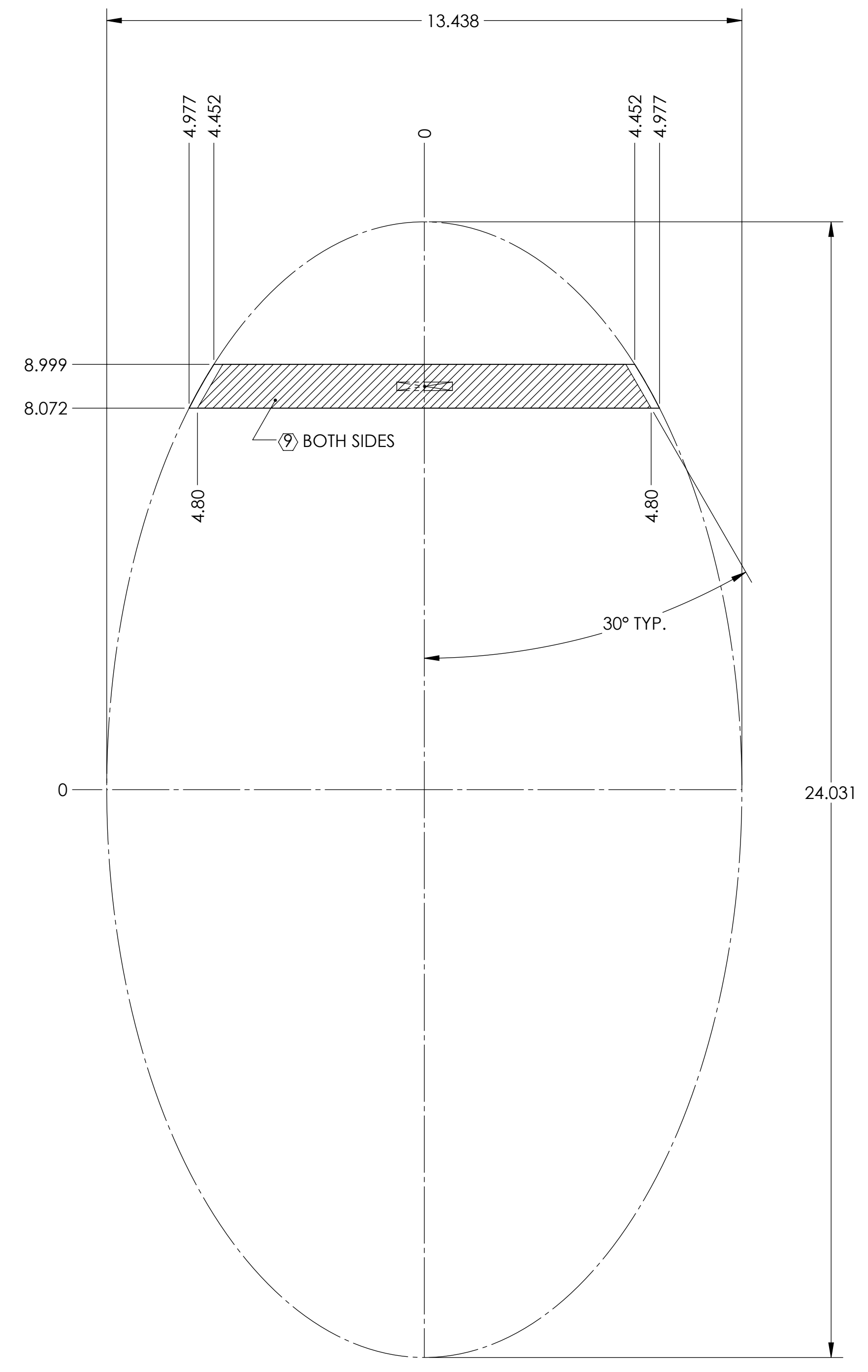

-5 DETAIL

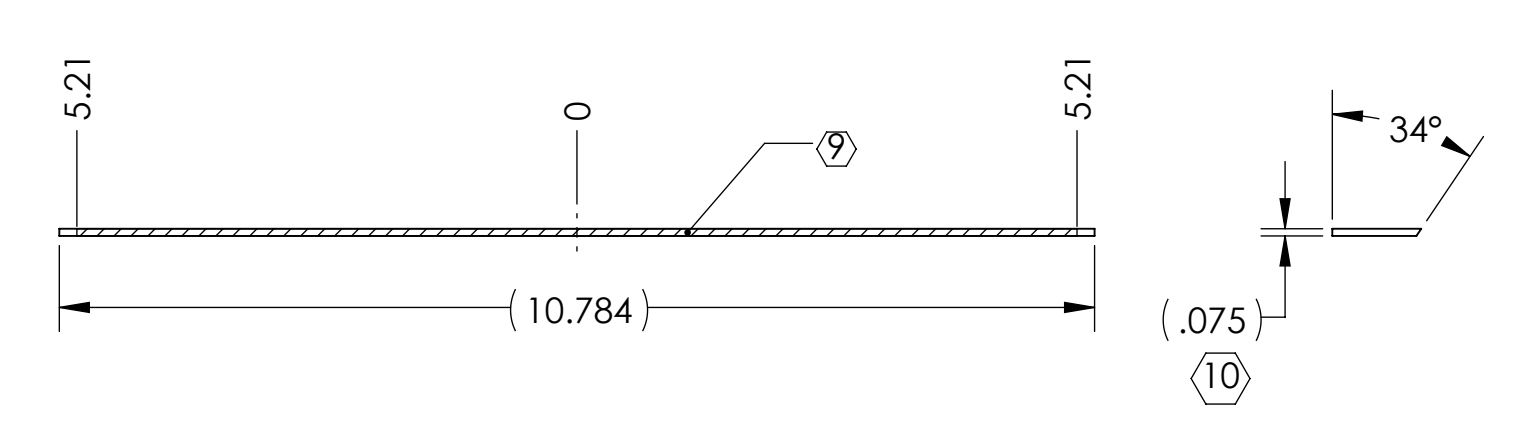
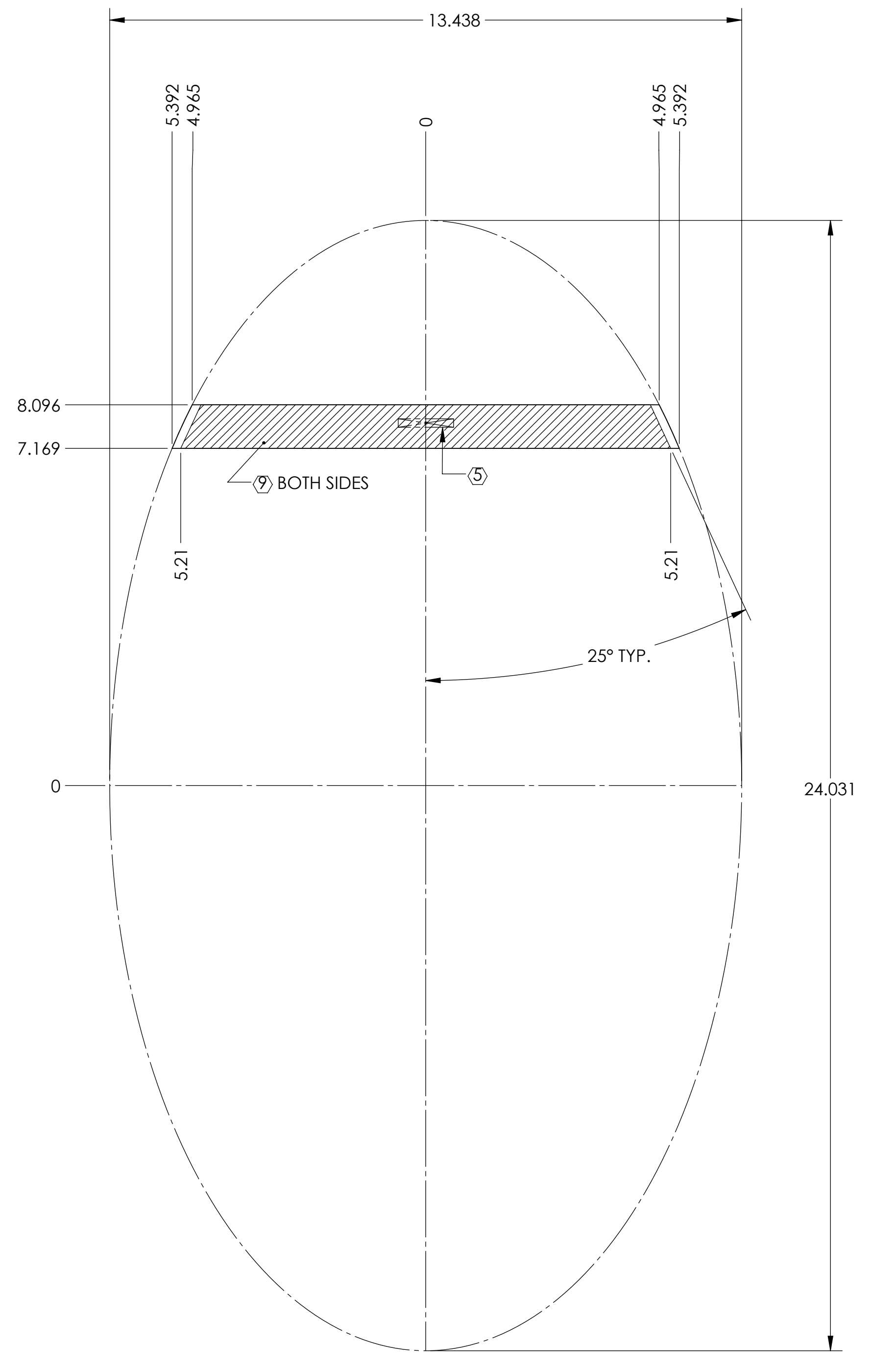

LIGO CALIFORNIA INSTITUTE OF TECHNOLOGY MASSACHUSETTS INSTITUTE OF TECHNOLOGY	
SIZE DWG. NO.	REV.
D D1600406	v2
SCALE: 1:2	PROJECTION:
SHEET 2 OF 9	

D1600406.dwg, VE, Chevron UV Baffle, LOUVER, PART FDM REV: X016, DRAWING FDM REV: X009

-6 DETAIL

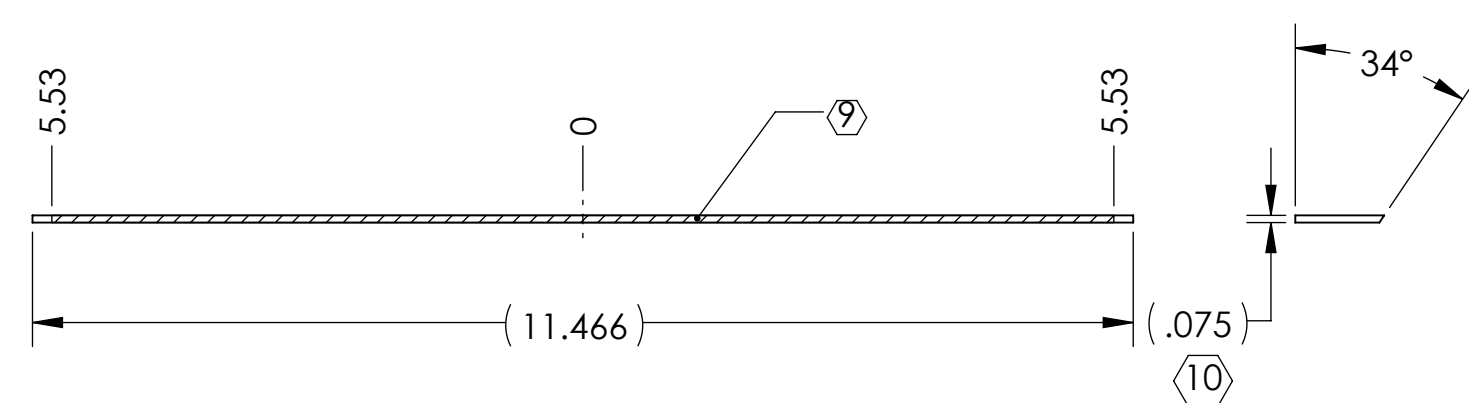
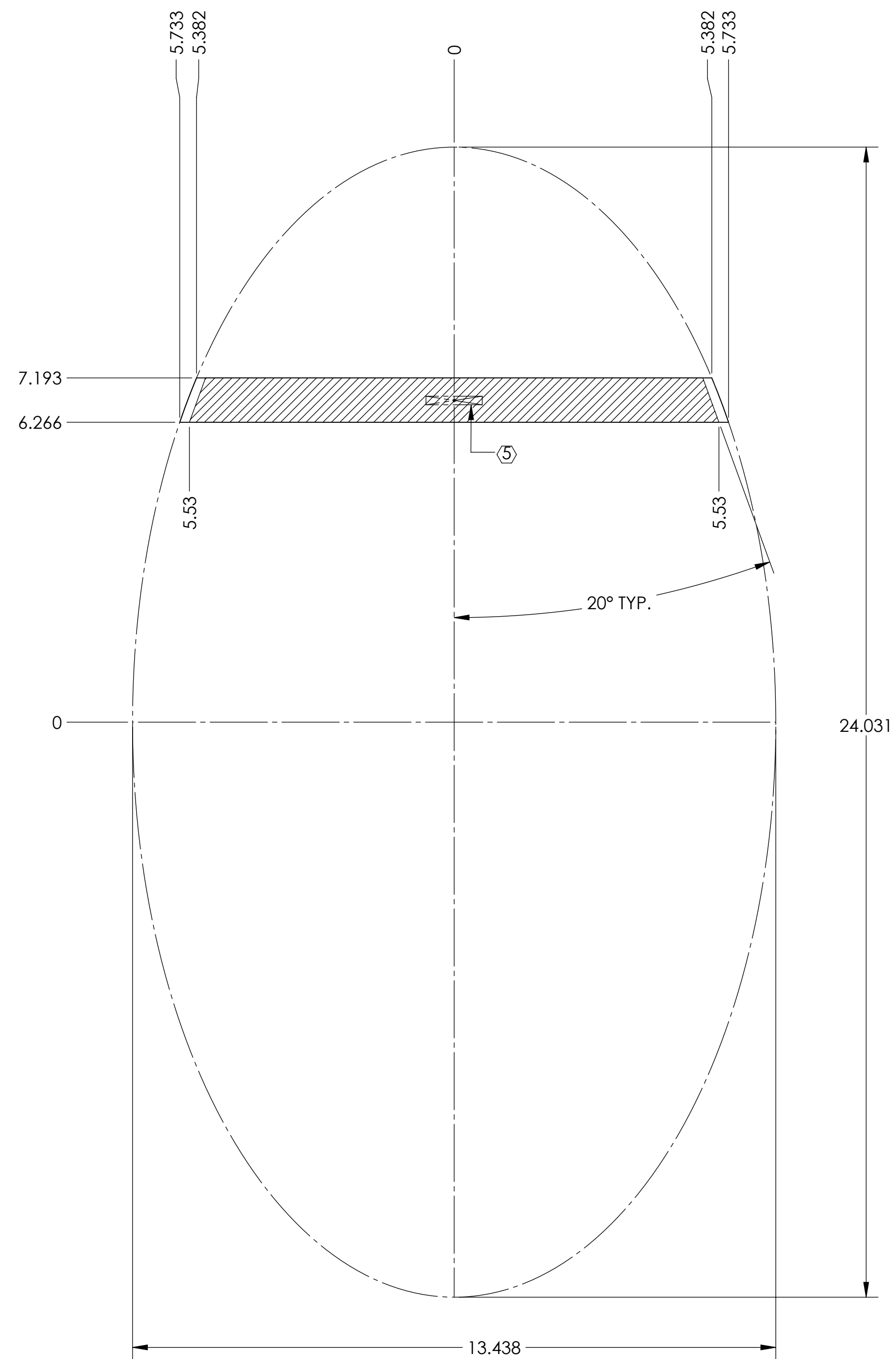

-7 DETAIL

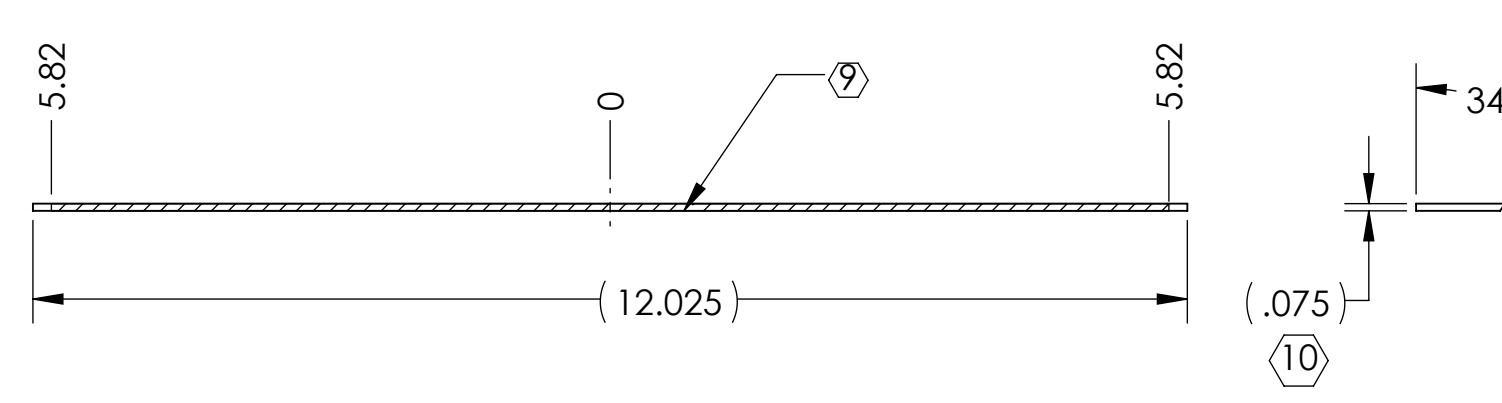
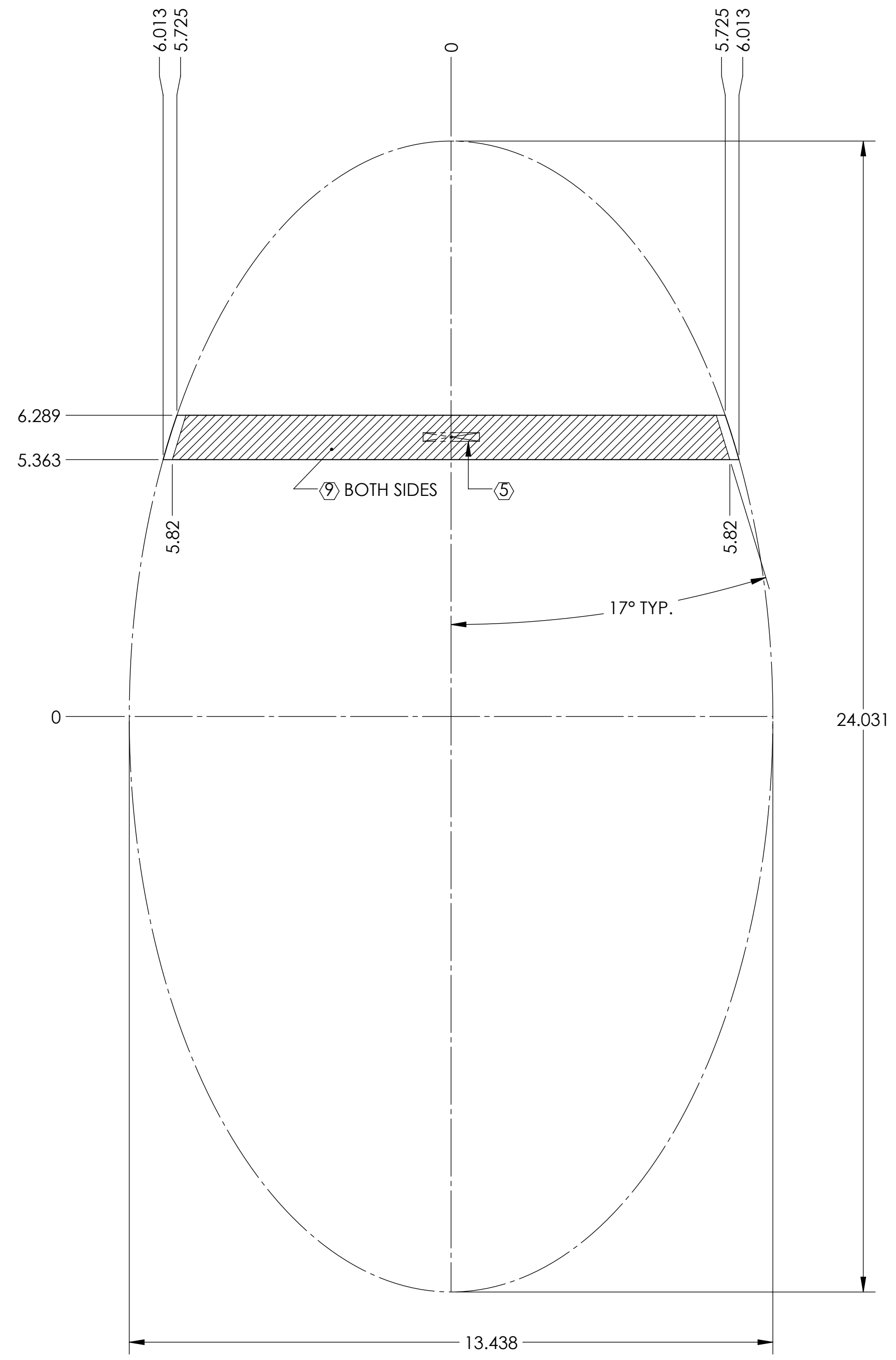

-8 DETAIL

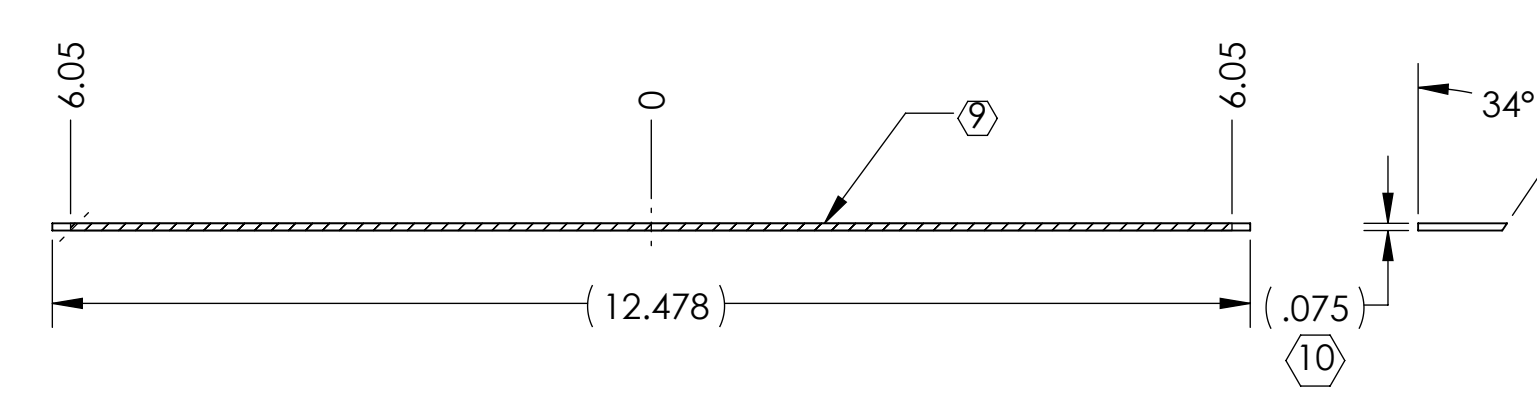
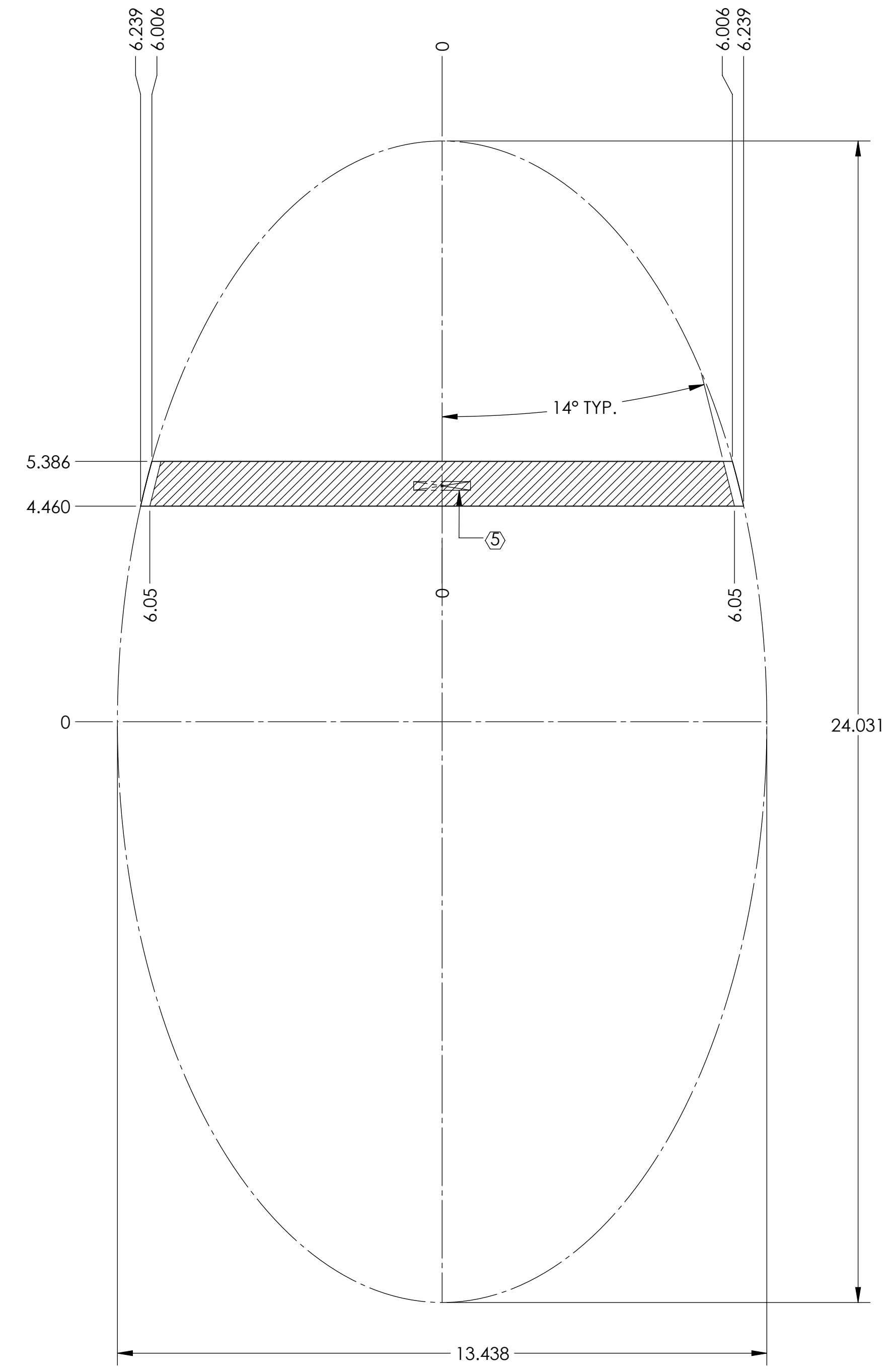

LIGO CALIFORNIA INSTITUTE OF TECHNOLOGY MASSACHUSETTS INSTITUTE OF TECHNOLOGY	
SIZE DWG. NO.	REV.
D D1600406	v2
SCALE: 1:2	PROJECTION:
SHEET 3 OF 9	

D1600406.dwg, VE, Chevron UV Baffle, LOUVER, PART FDM REV. X016, DRAWING FDM REV. X009

-9 DETAIL

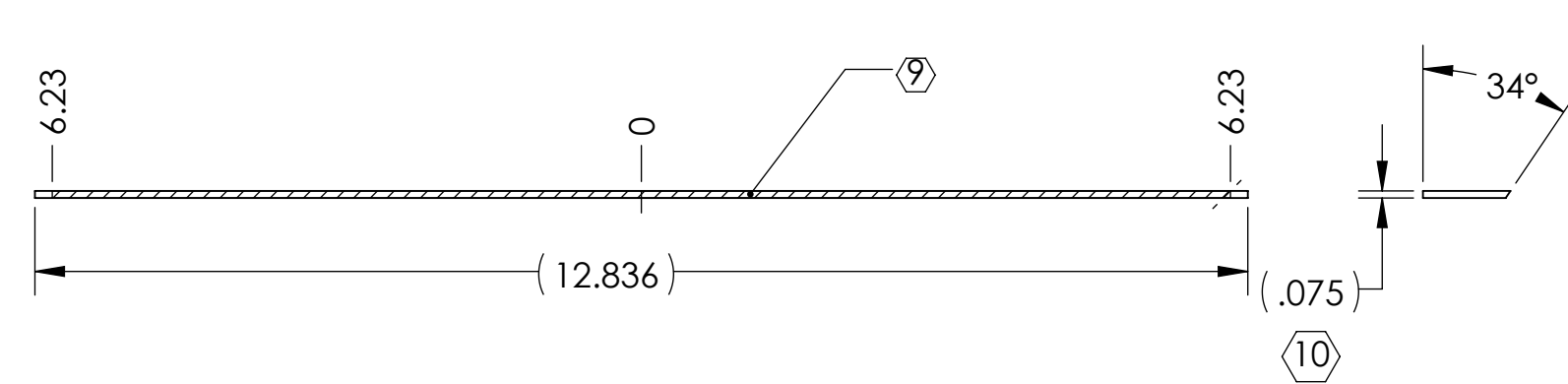
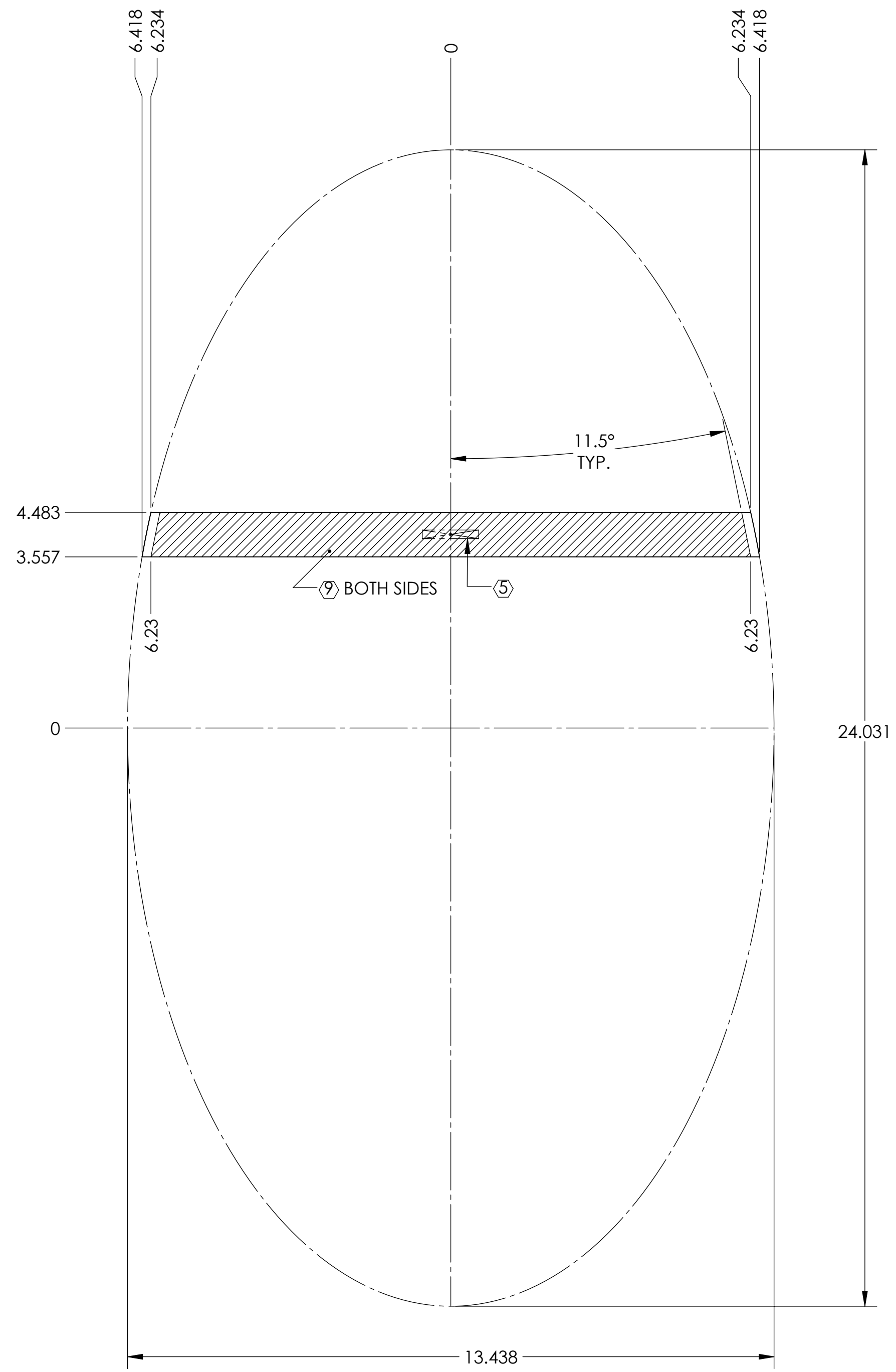

-10 DETAIL

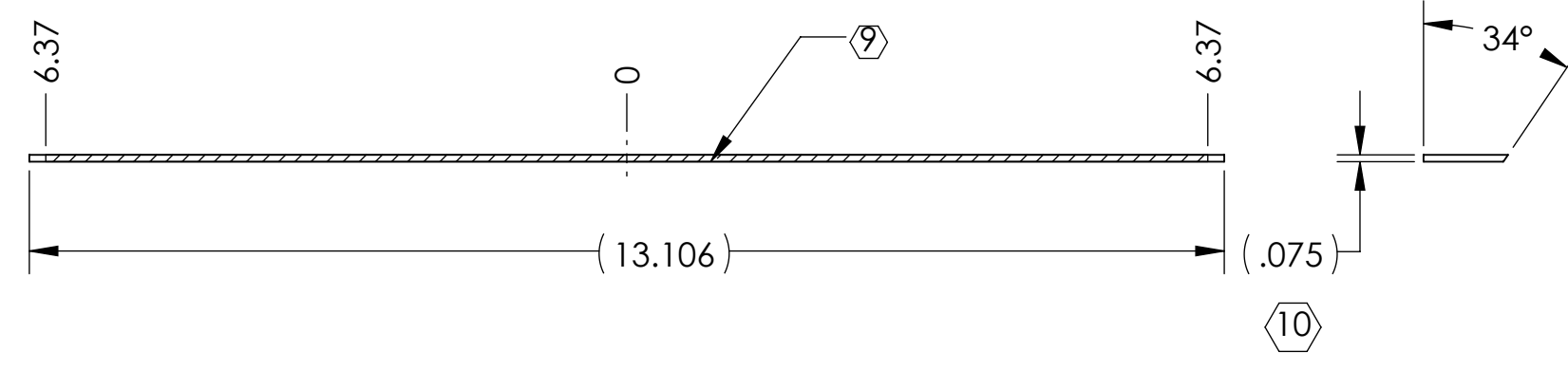
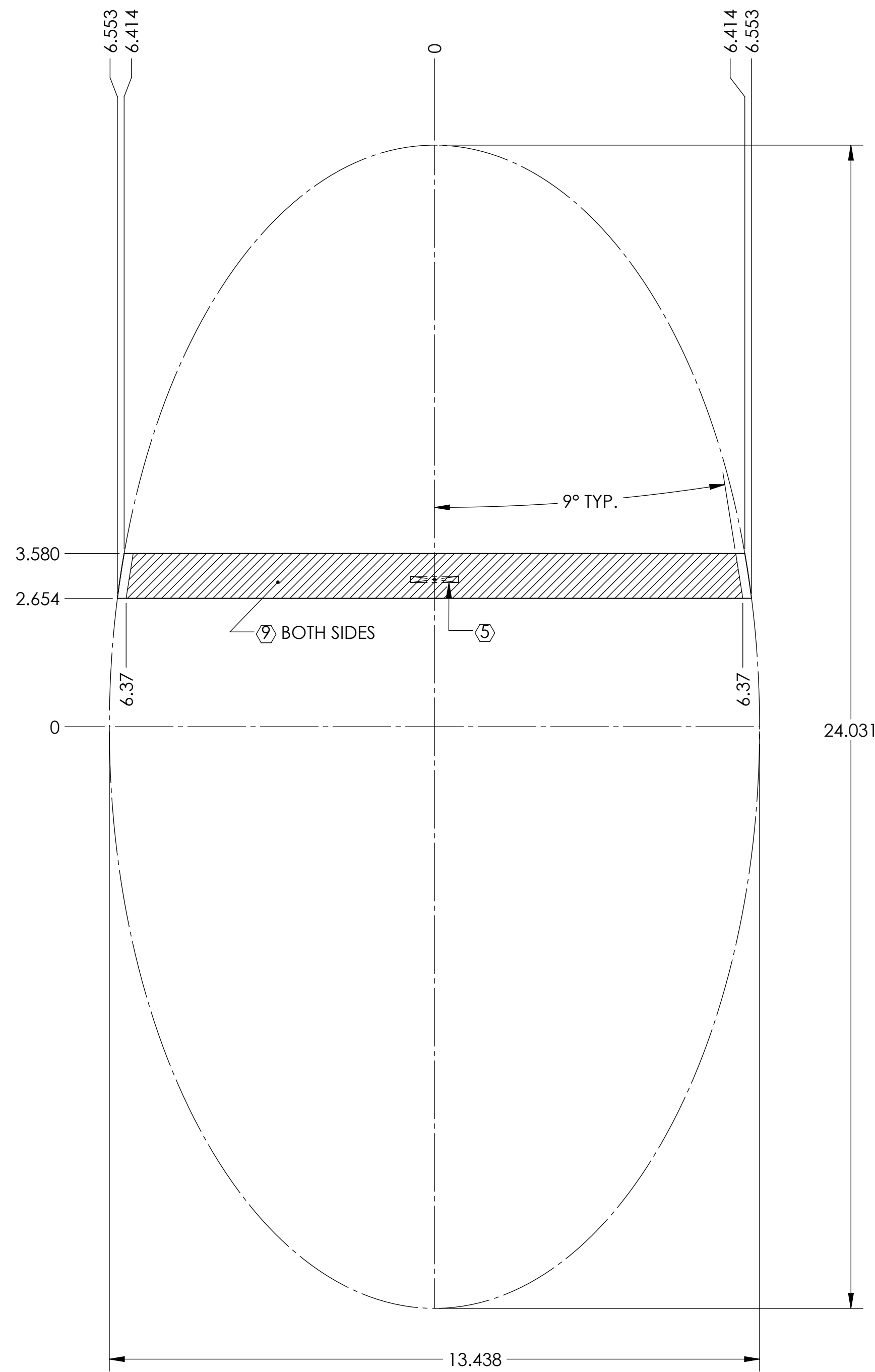

-11 DETAIL

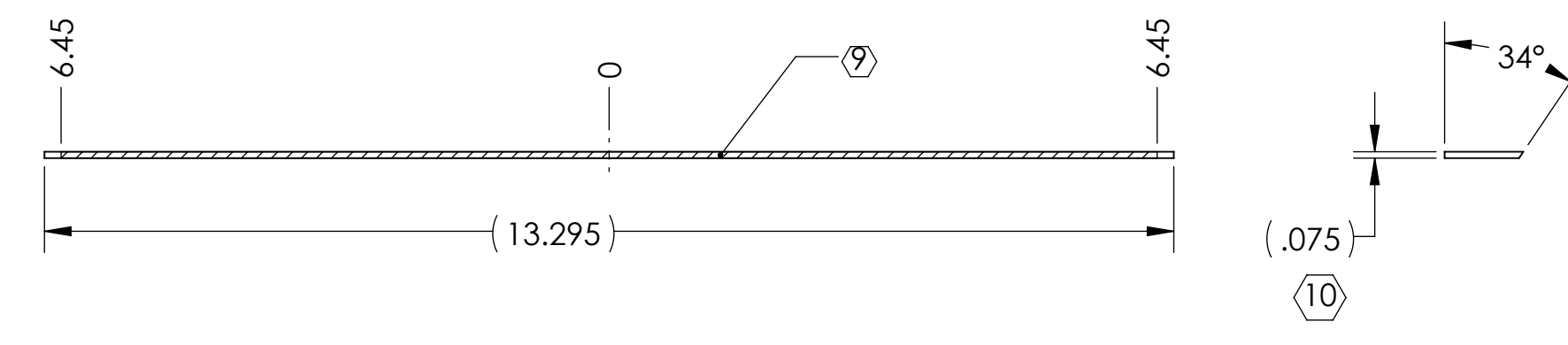
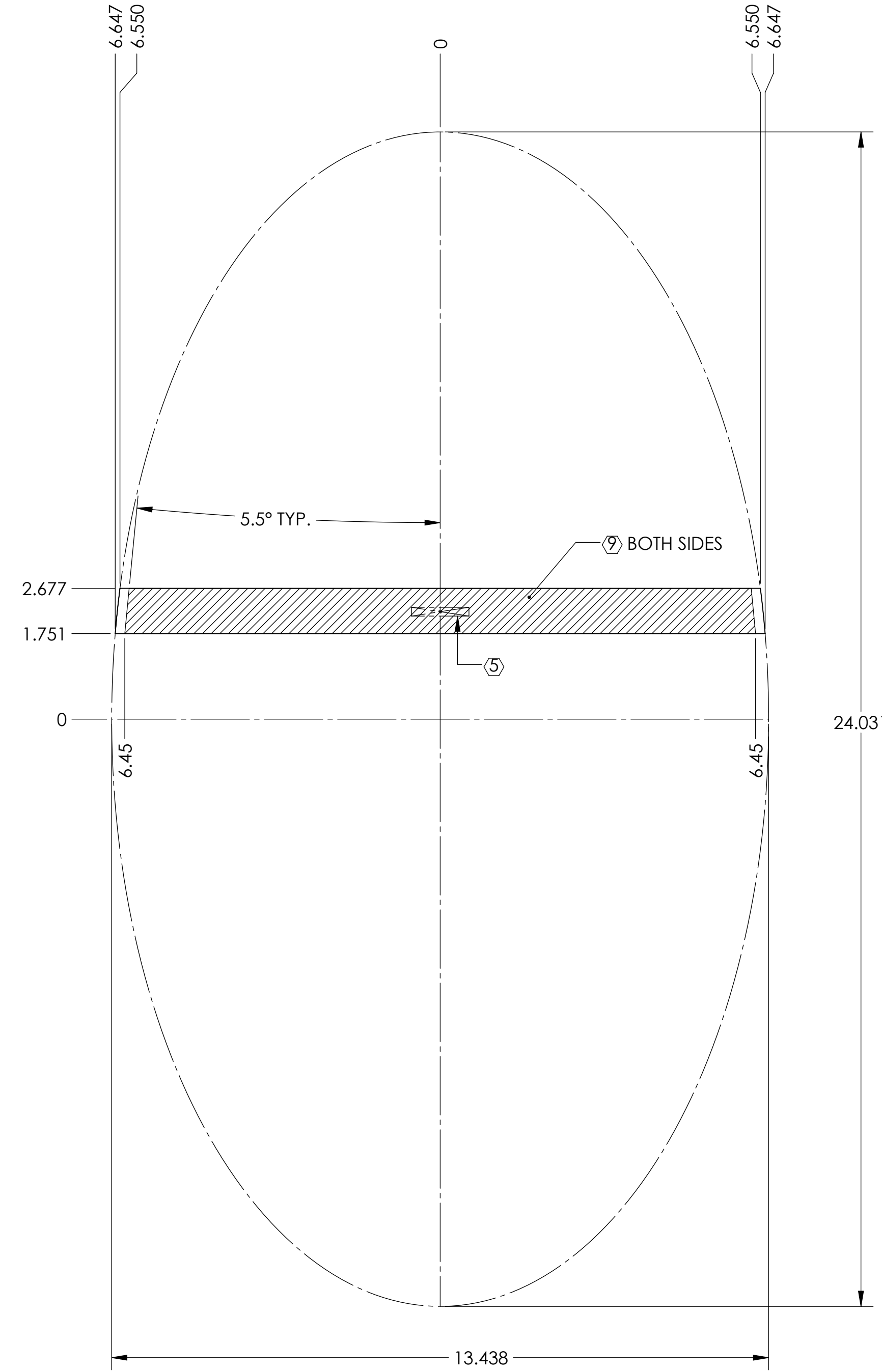

LIGO CALIFORNIA INSTITUTE OF TECHNOLOGY
MASSACHUSETTS INSTITUTE OF TECHNOLOGY

SIZE	DWG. NO.	REV.
D	D1600406	v2
SCALE: 1:2	PROJECTION:	SHEET 4 OF 9

D1600406.dwg, VE, Chevron UV Baffle, LOUVER, PART FDM REV: X016, DRAWING FDM REV: X009

-12 DETAIL

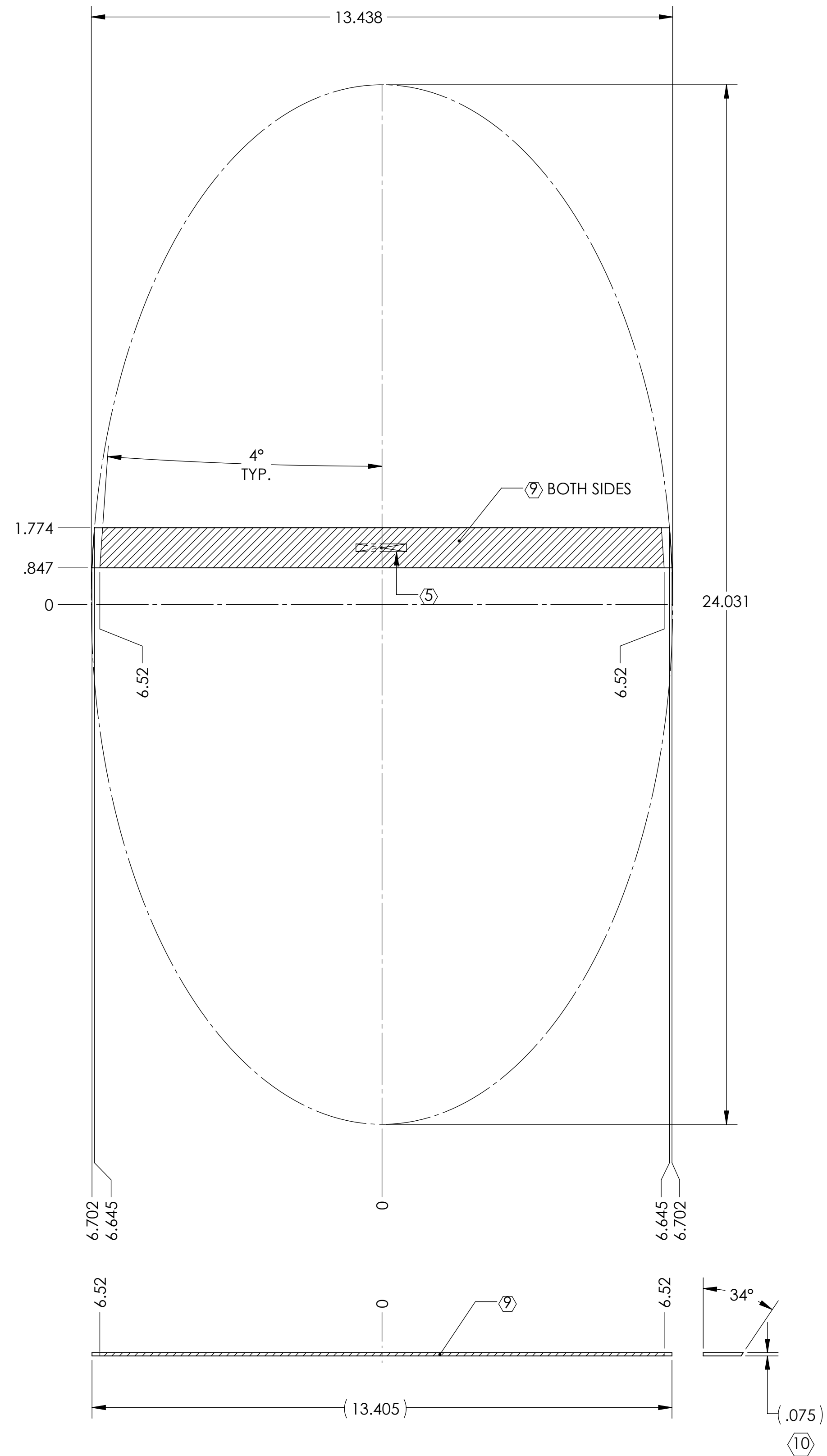

-13 DETAIL

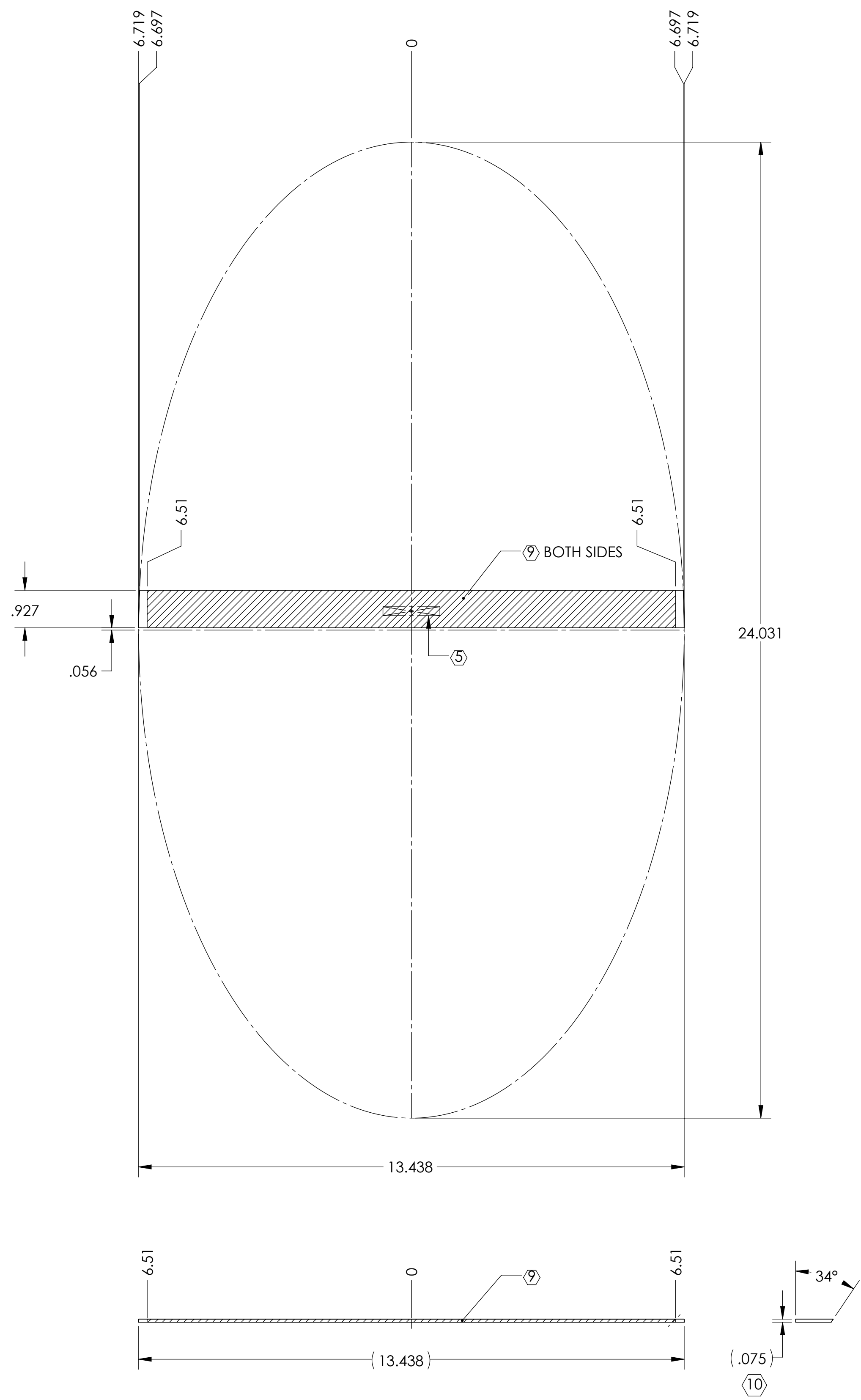

-14 DETAIL

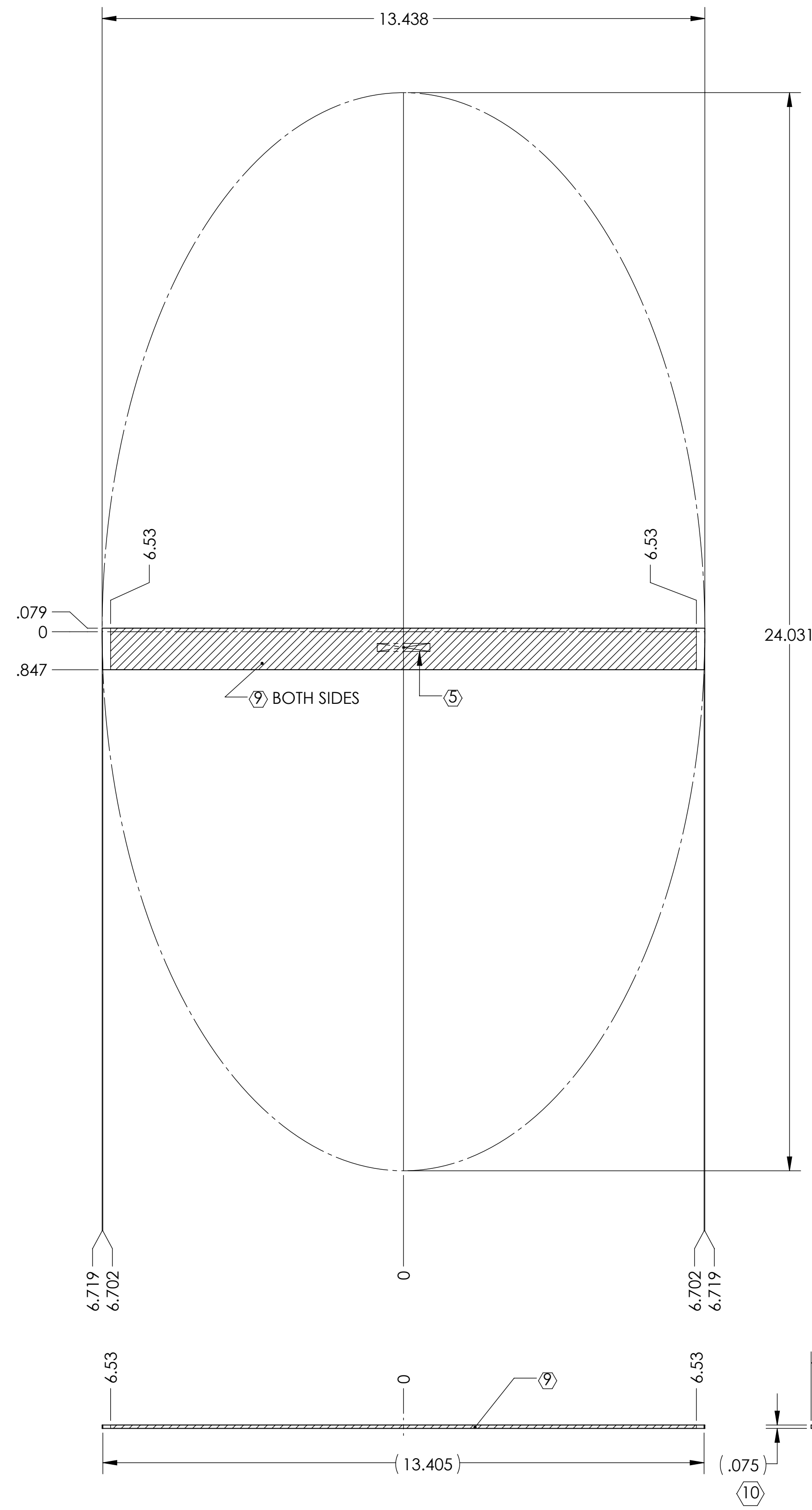

D:\600406.dwg, VIE Chevron UV Baffle, LOUVER, PART FDM REV. X016, DRAWING FDM REV. X009

-15 DETAIL

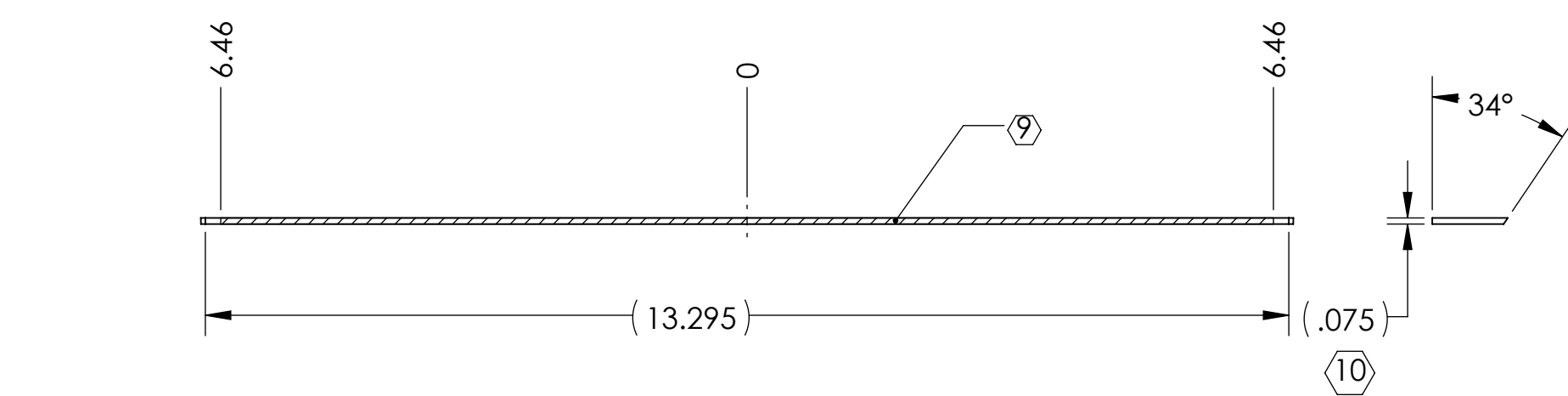
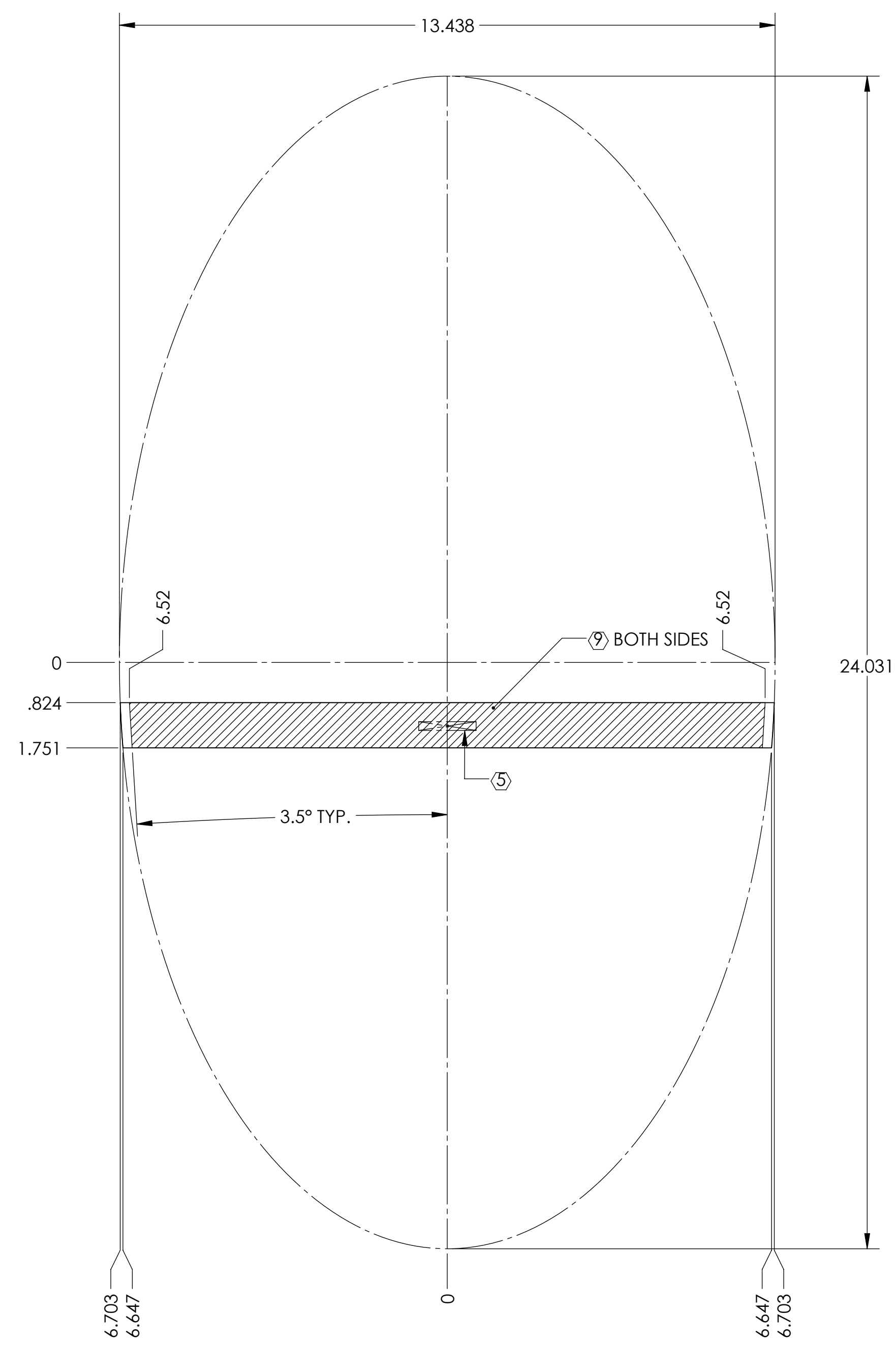

-16 DETAIL

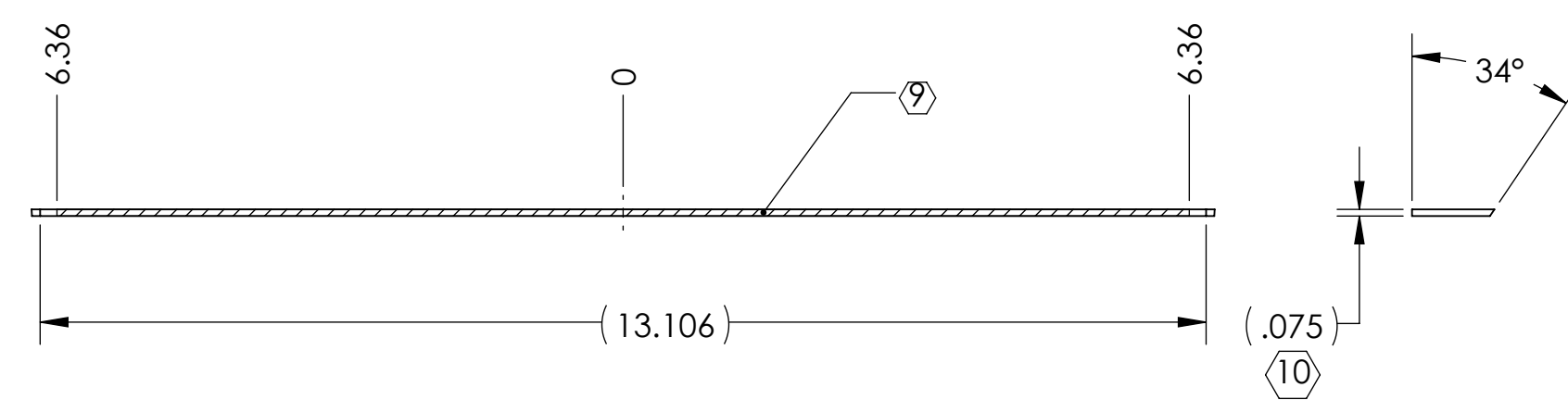
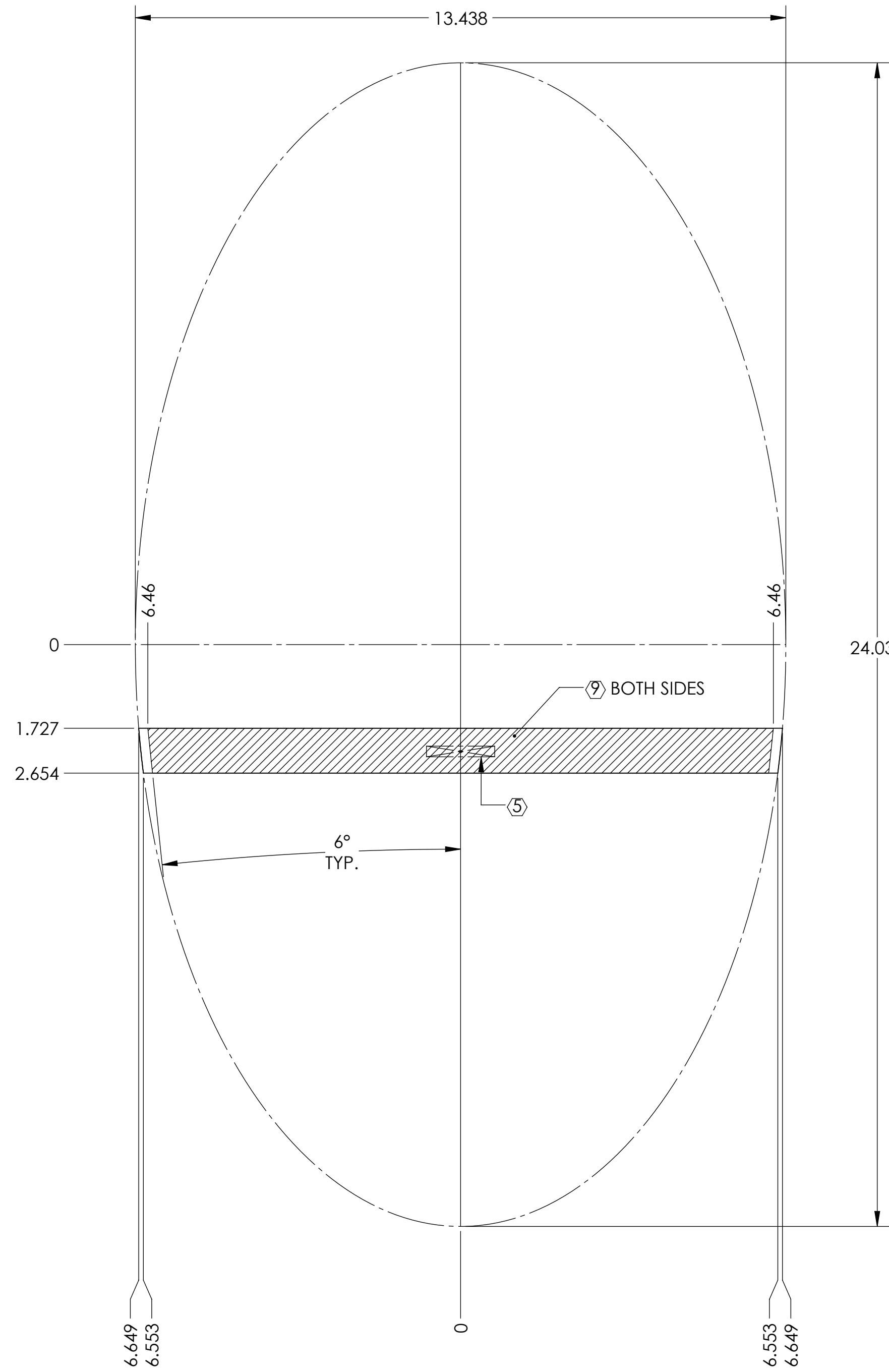

-17 DETAIL

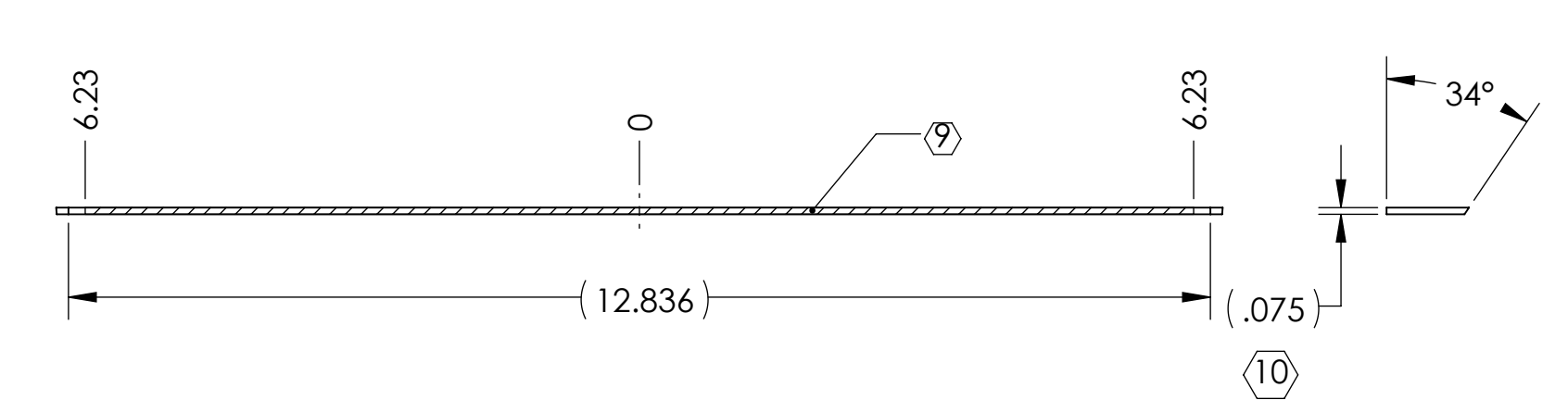
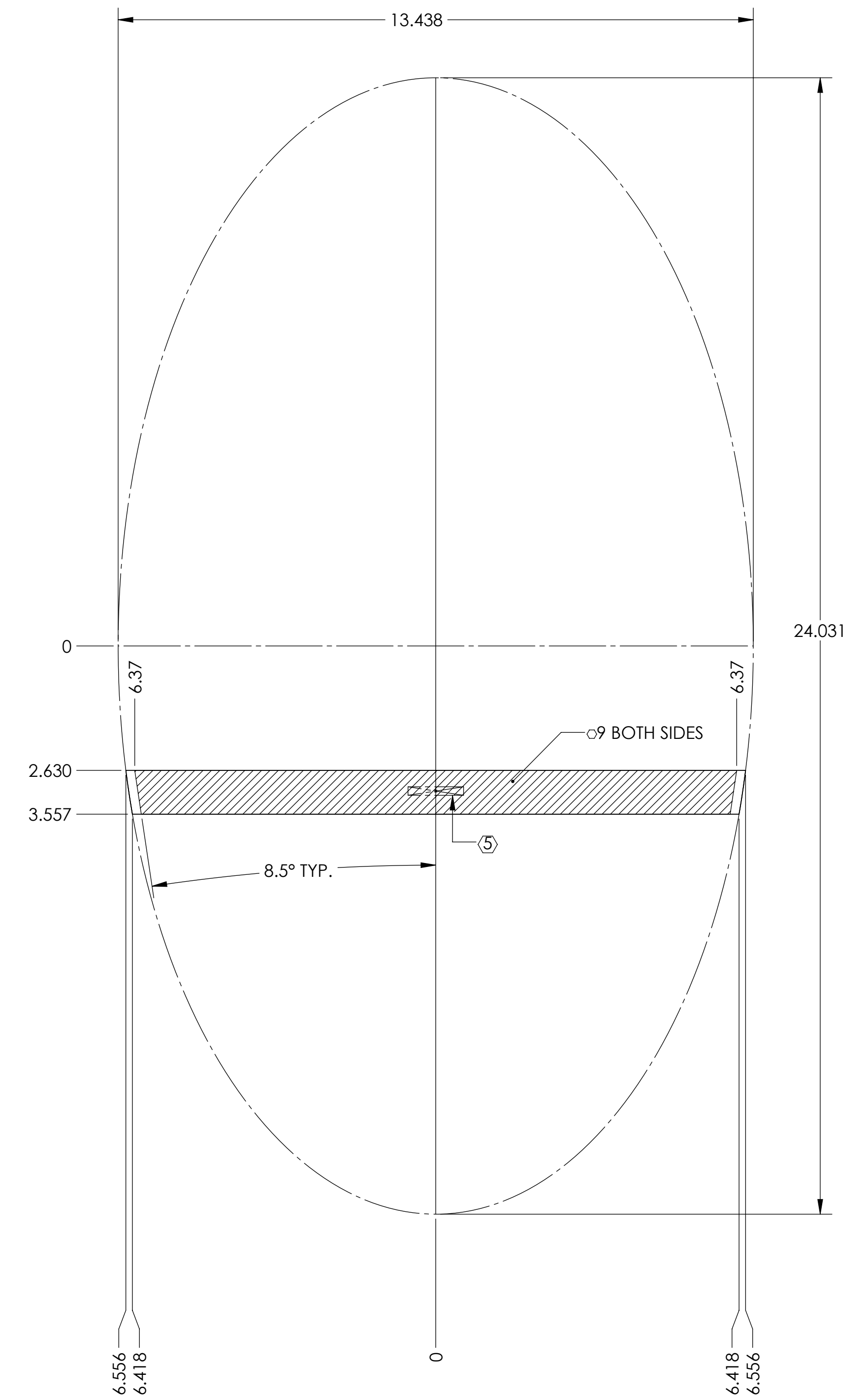

LIGO CALIFORNIA INSTITUTE OF TECHNOLOGY
MASSACHUSETTS INSTITUTE OF TECHNOLOGY

SIZE	DWG. NO.	REV.
D	D1600406	v2
SCALE: 1:2	PROJECTION:	SHEET 6 OF 9

D:\600406\dligo_1\IE_Chevron UV Baffle_LOUVER_PART_FDM_REV.X2016_DRAWING_FDM_REV.X09

-18 DETAIL

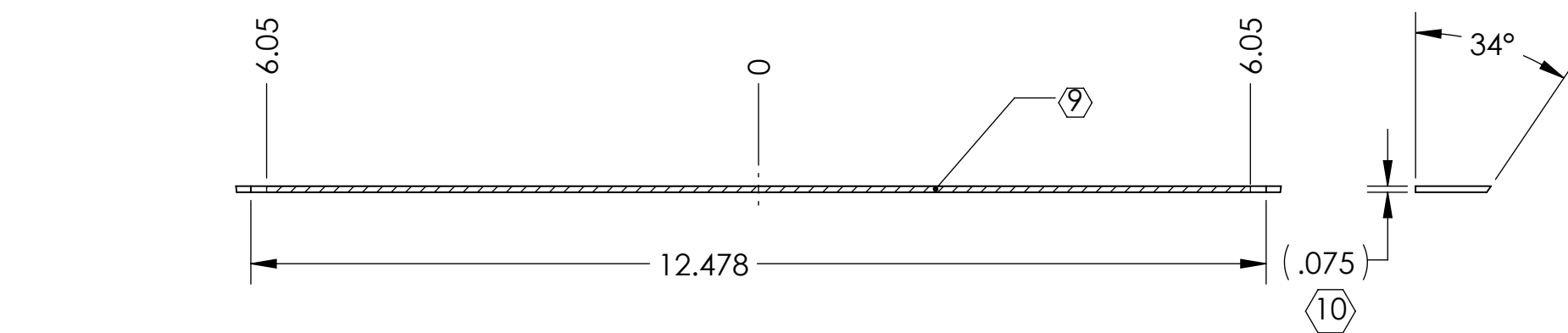
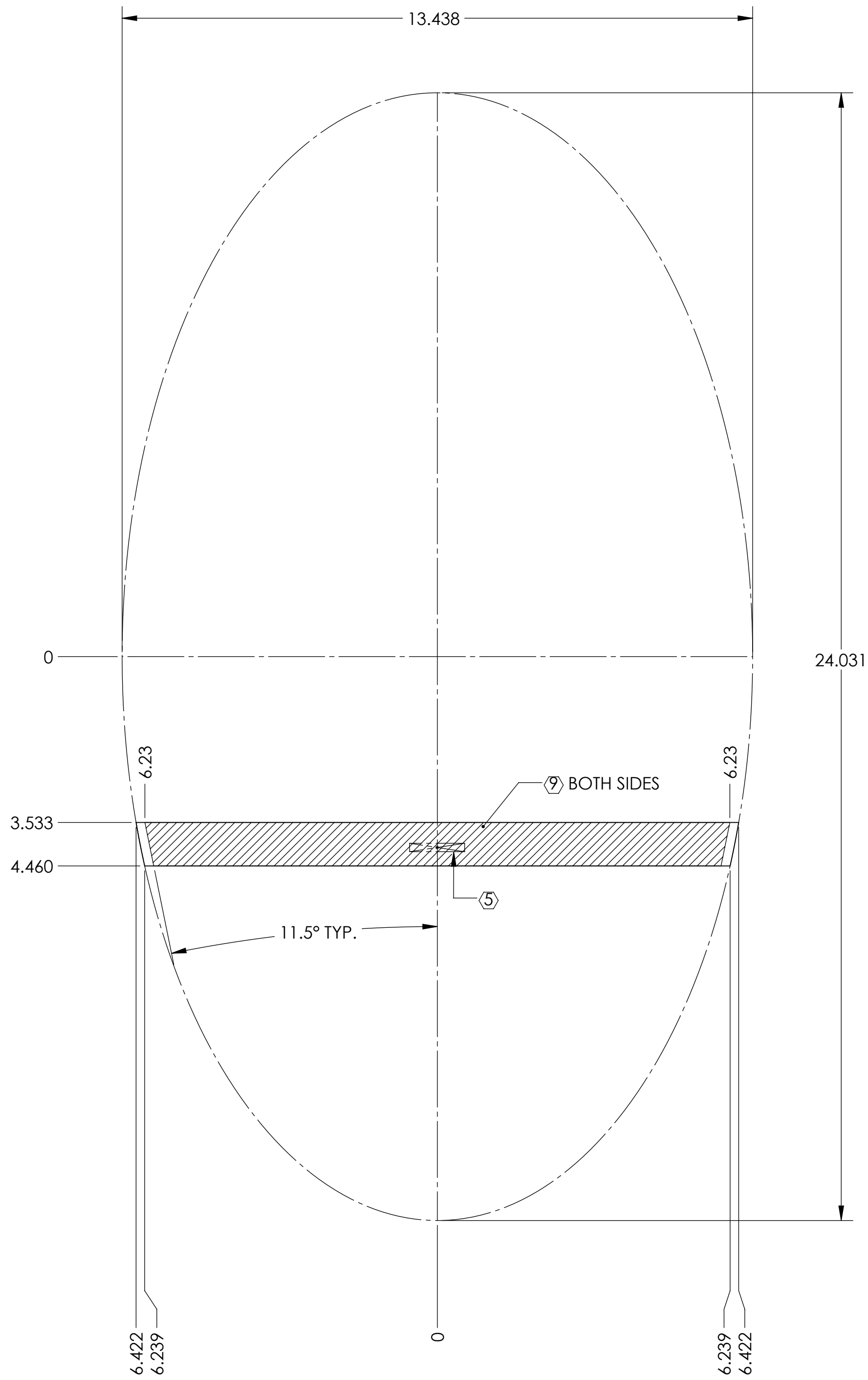

-19 DETAIL

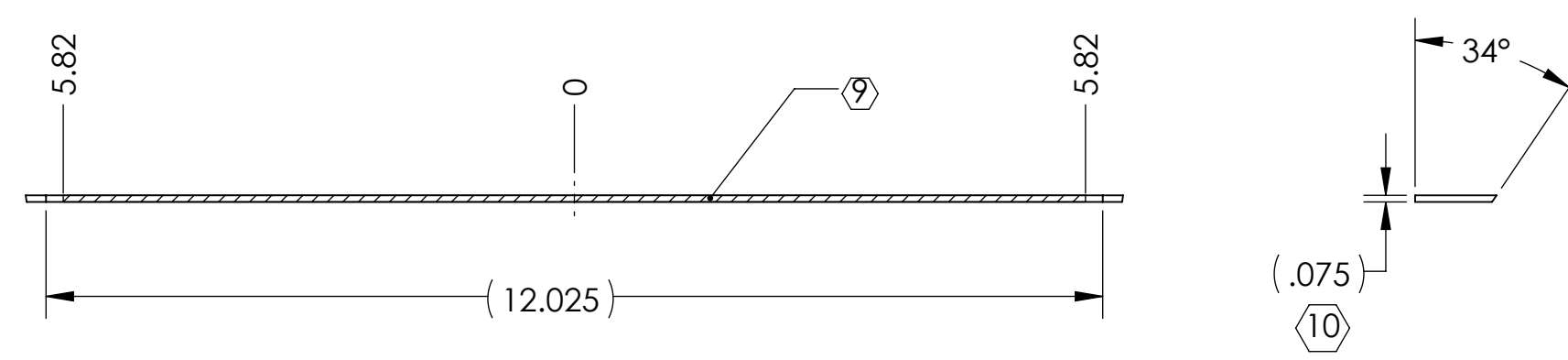
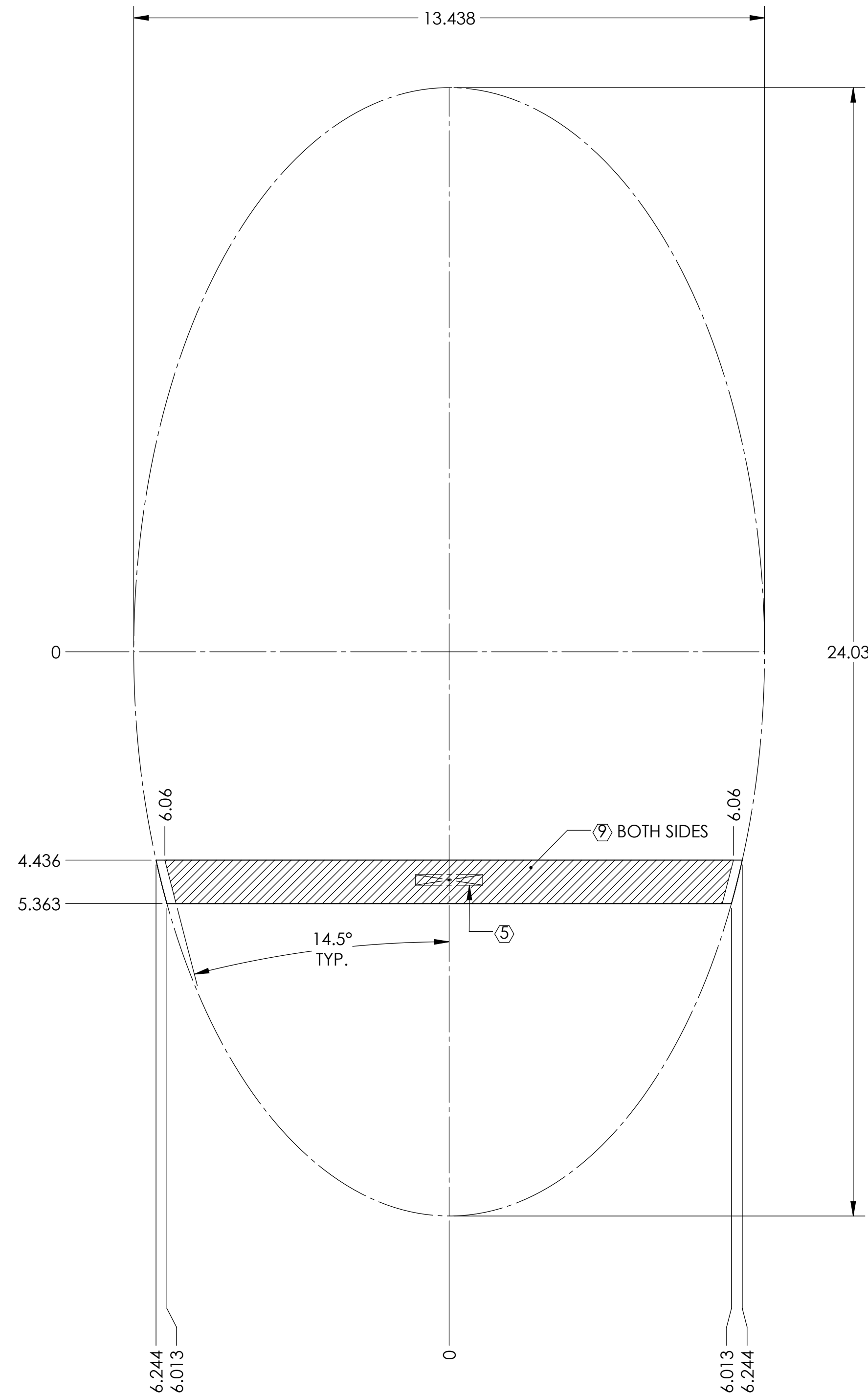

-20 DETAIL

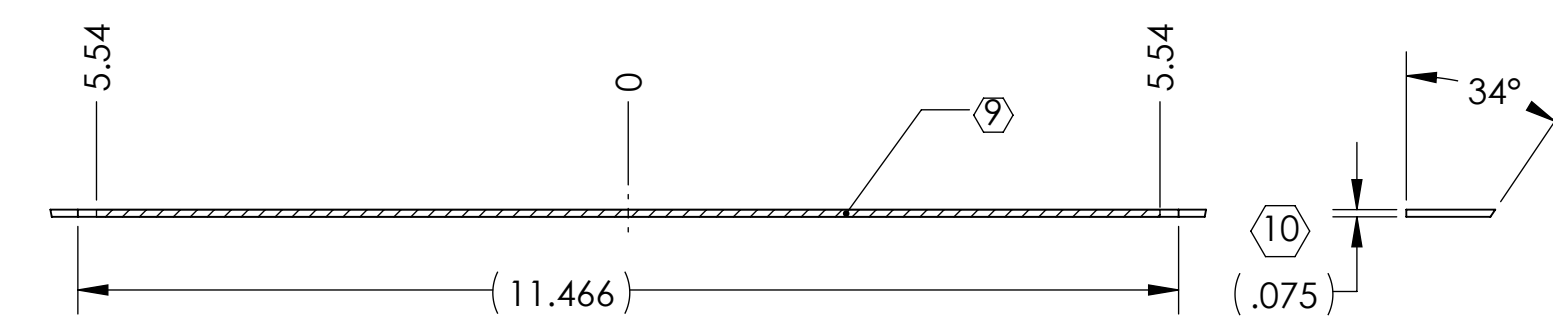
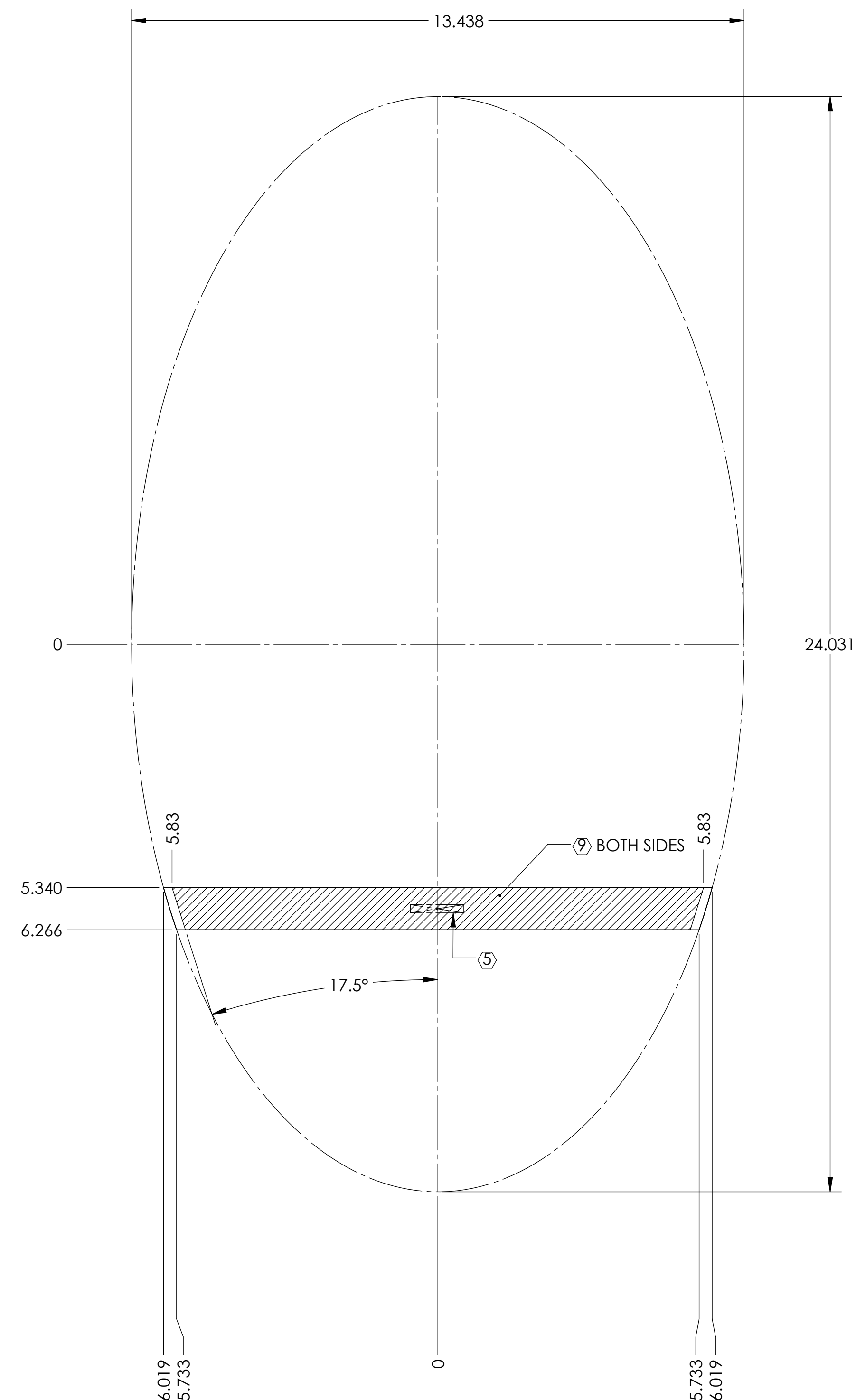

LIGO CALIFORNIA INSTITUTE OF TECHNOLOGY MASSACHUSETTS INSTITUTE OF TECHNOLOGY	
SIZE DWG. NO.	REV.
D D1600406	v2
SCALE: 1:2	PROJECTION:
SHEET 7 OF 9	

D1600406.dwg, VIE Chevron LV Baffle, LOUVER, PART FDM REV. X.016, DRAWING FDM REV. X.009

-21 DETAIL

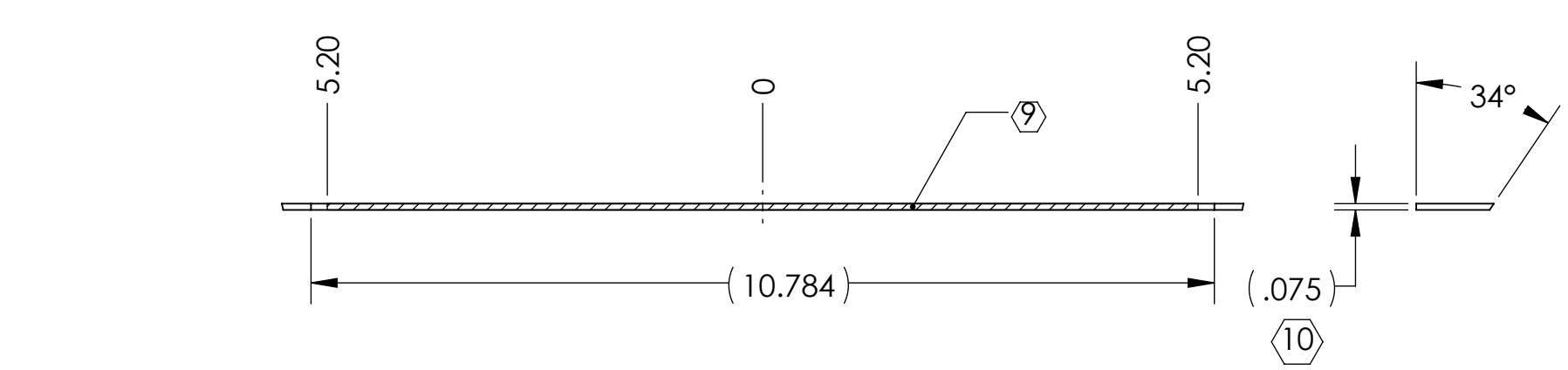
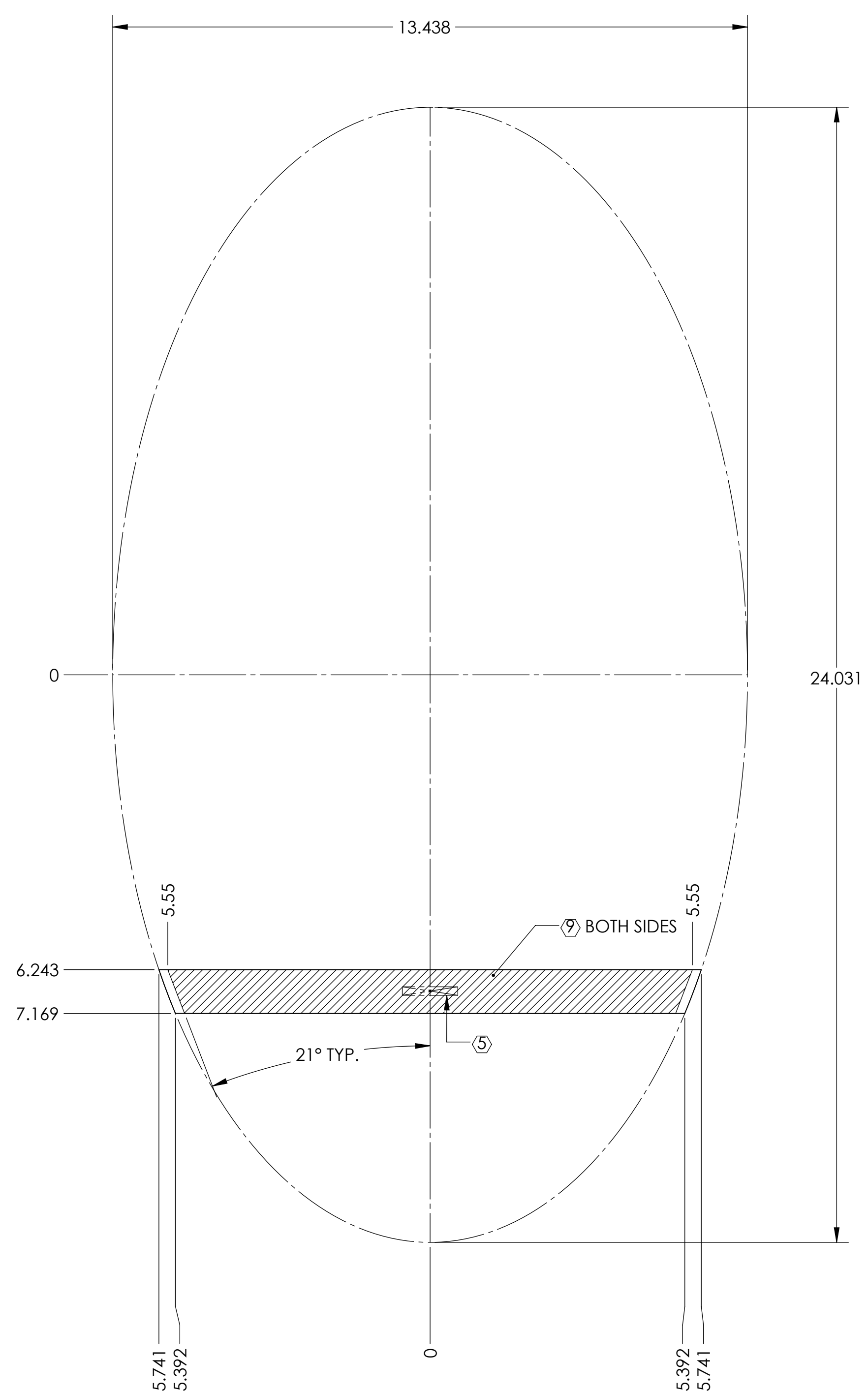

-22 DETAIL

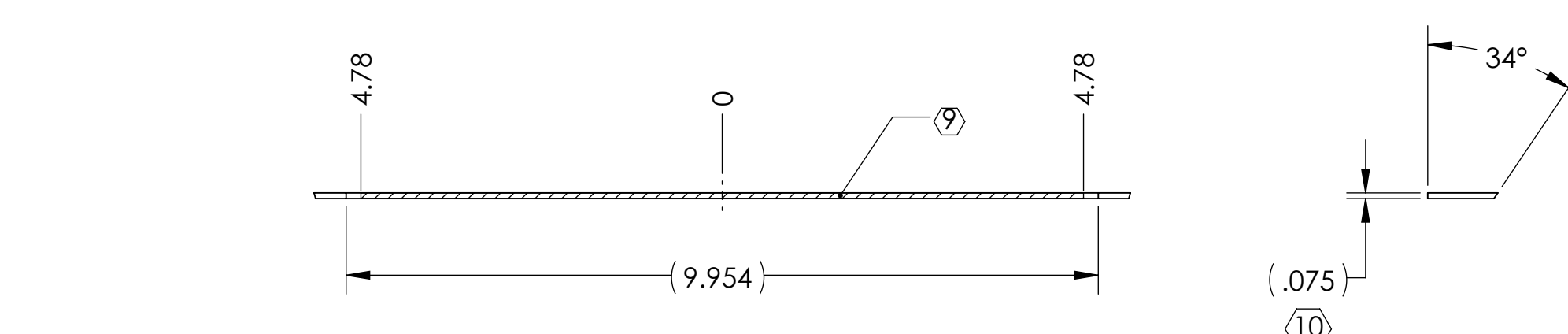
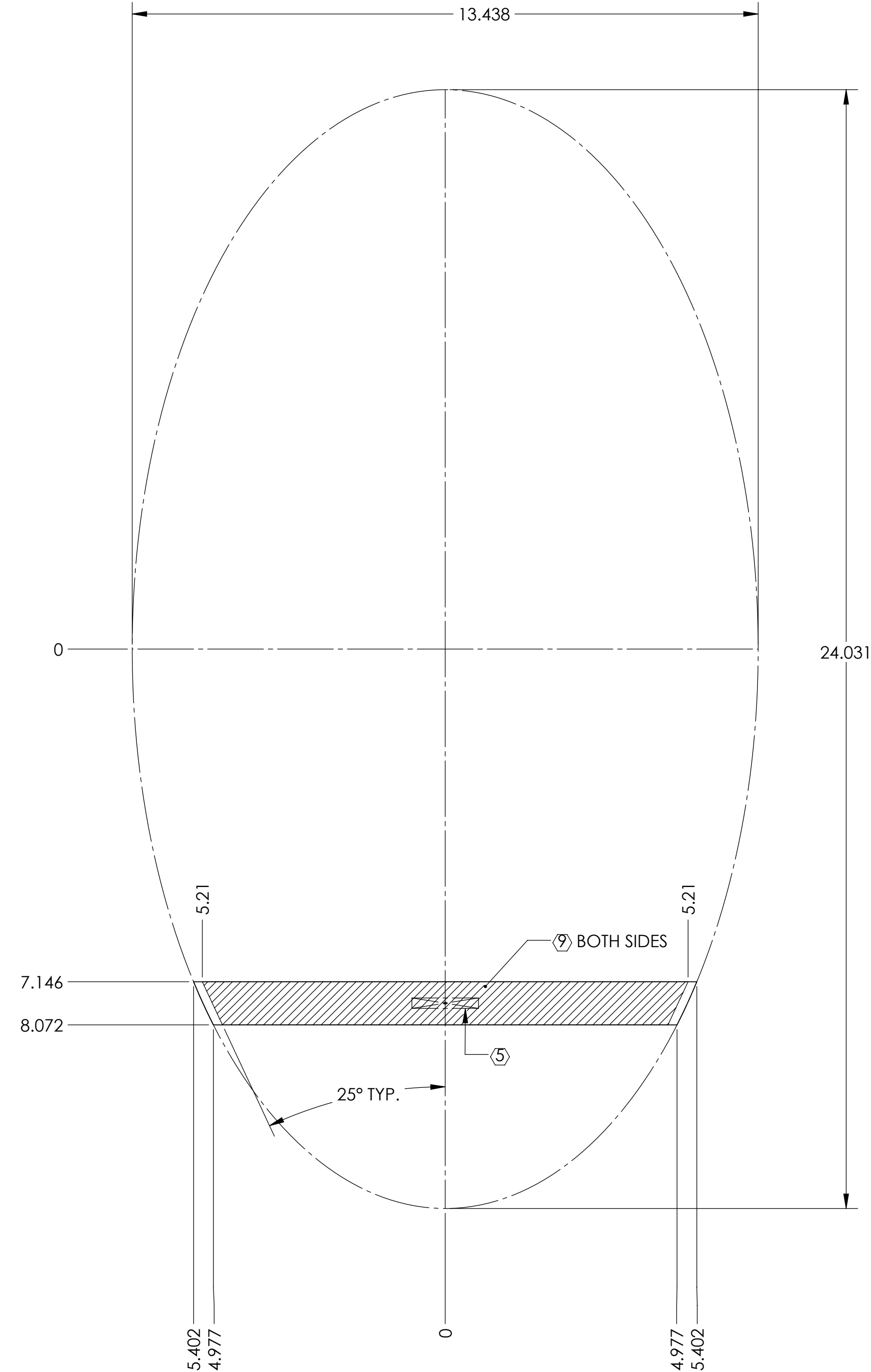

-23 DETAIL

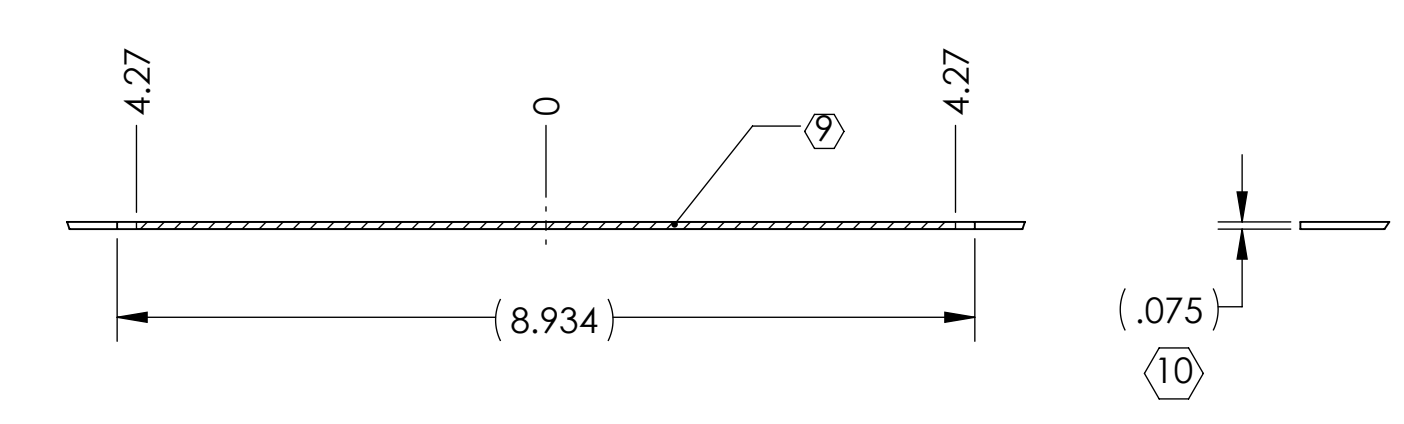
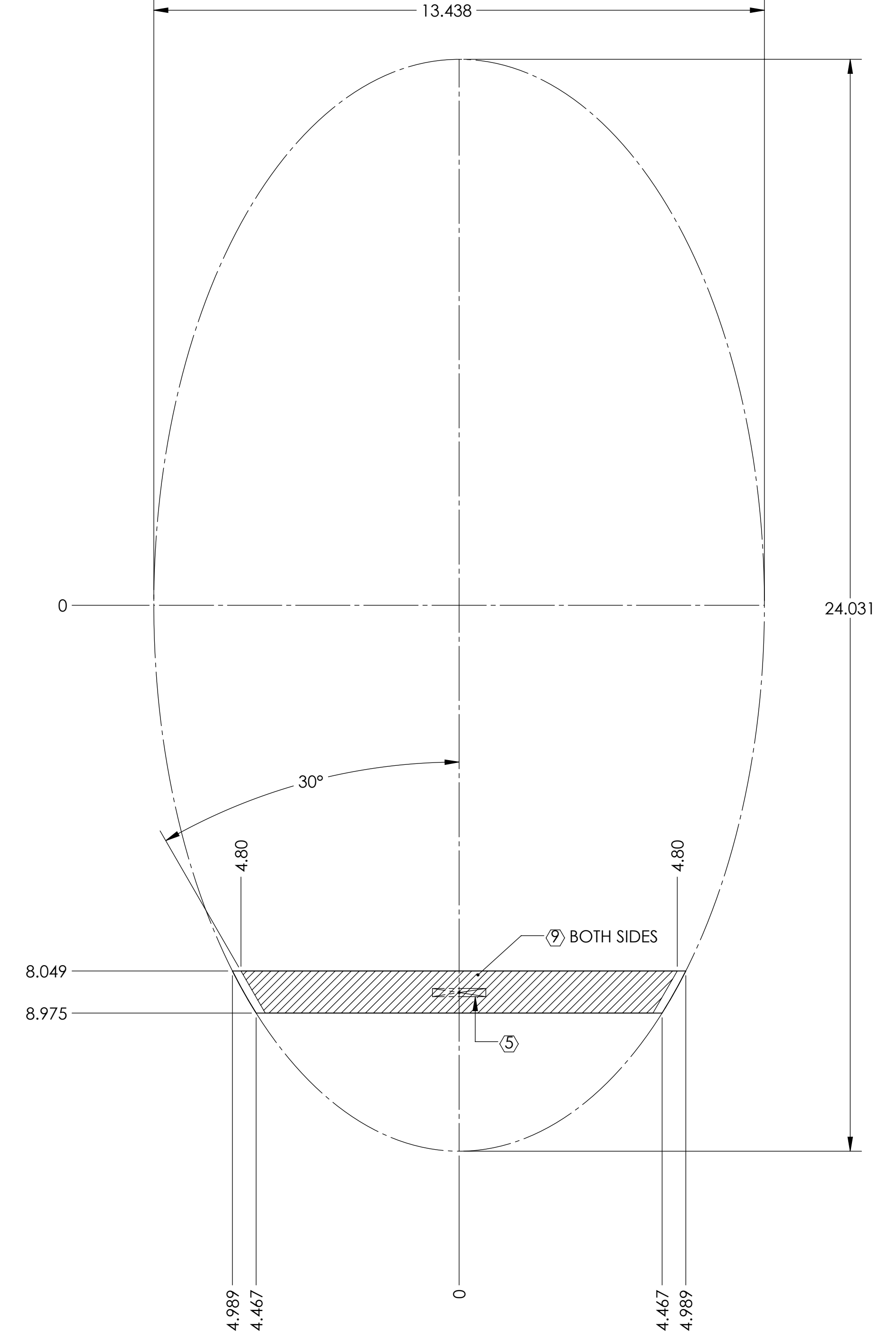

D1600406.dwg, VE, Chevron UV Baffle, LOUVER, PART FDM REV. X016, DRAWING FDM REV. X009

-24 DETAIL

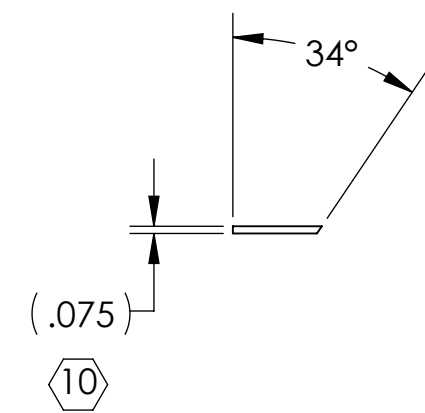
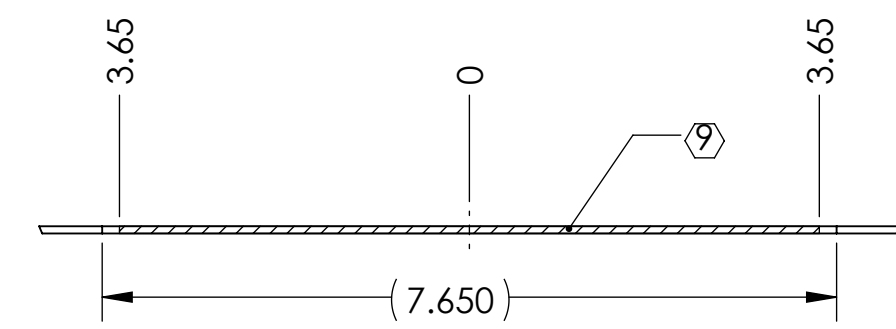
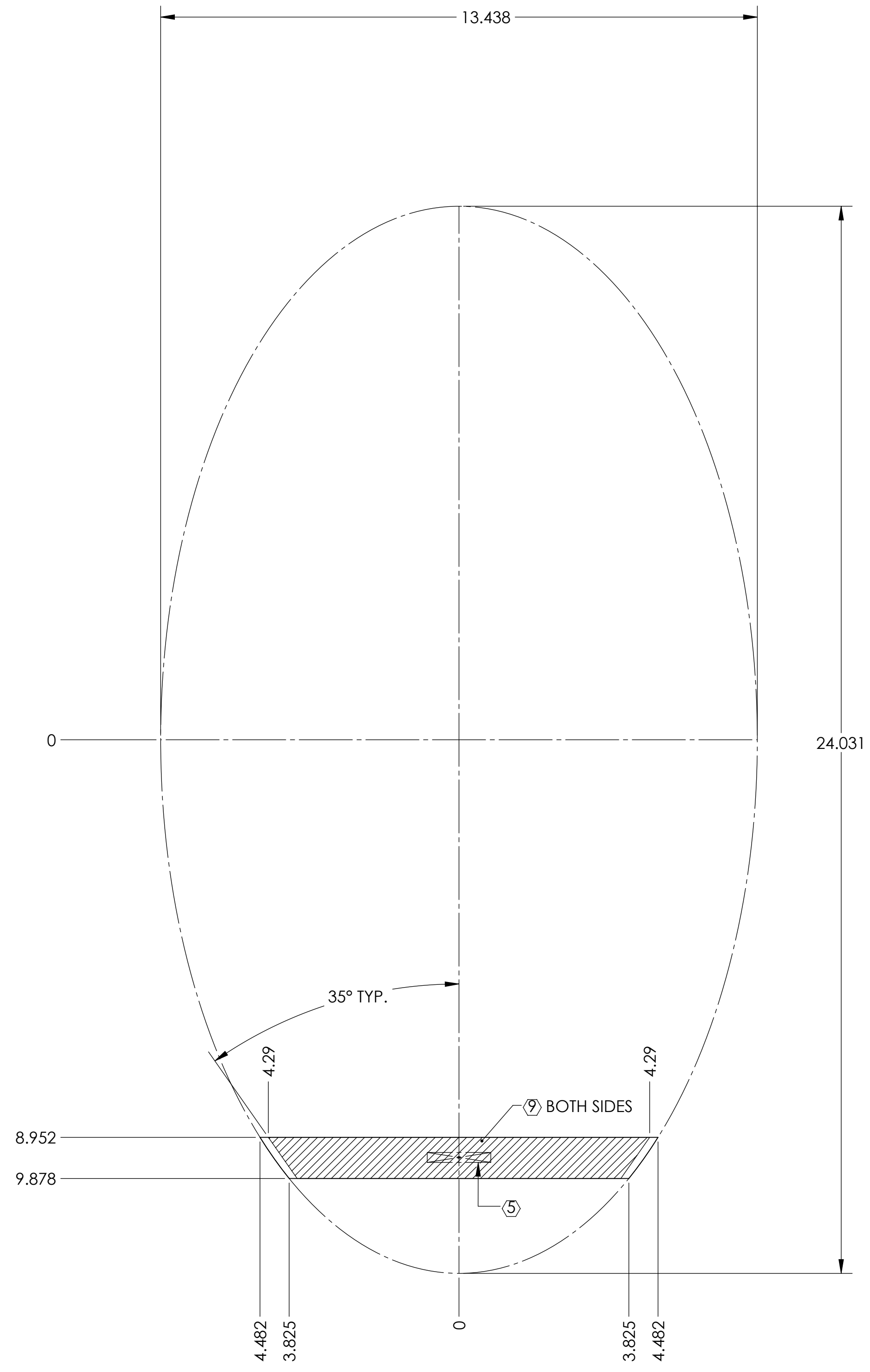

-25 DETAIL

