

3 UNDERSTANDING AND IMPROVING THE ACCURACY OF ADVANCED LIGO CALIBRATION

4 M. MCINTOSH¹
ADVISED BY C. CAHILLANE,² A. WEINSTEIN,² K. BLACKBURN,²

5
6 ¹HARVARD UNIVERSITY DEPARTMENT OF ASTRONOMY, 60 GARDEN STREET, CAMBRIDGE, MA 02138, USA
7 ²LIGO, CALIFORNIA INSTITUTE OF TECHNOLOGY, PASADENA, CALIFORNIA 91125, USA
8 LIGO LABORATORY CALTECH SURF PROGRAM PROGRESS REPORT #1
9 LIGO-T1600260
10 JULY 5, 2016

11 I. FIRST PROGRESS REPORT QUESTIONS

12 **Write in some detail the motivation for your**
13 **project. It should include background and an**
14 **overview of the ongoing work in the laboratory.**
15 **You should include references.**

16 See Section II for motivation and background (it is a
17 draft of the introduction for my final paper). Ongoing
18 work includes reading TIGER and testing-GR papers as
19 recommended by Alan.

20 **Discuss the problem you are working on and ex-**
21 **plain how it fits into the ongoing work. Explain**
22 **your approach and outline the methods you ex-**
23 **pect to use.**

24 I am working on running parameter estimation through
25 the LALInferencemcmc pipeline for various calibration
26 parameters. This is the heart of the project as it is how I
27 will recover my parameter estimations after forming soft-
28 ware signal injections. My approach includes using on-
29 line documentation and my mentors' recommendations
30 on running instructions and parameter values.

31 **Discuss the progress you have made on your**
32 **project, your goals for the next month, and the**
33 **methods or approach you will use to reach your**
34 **research goals.**

35 In the last two weeks, I have worked on/attended/been
36 introduced to:

- 37 • an introductory lecture on gravitational wave as-
- 38 tronomy
- 39 • the parameters for compact binary coales-
- 40 cence/Kerr parameters, black hole perturbation
- 41 theory
- 42 • an introductory lecture on linear time invariant sys-
- 43 tems control, convolution theory
- 44 • lectures on LIGO instrumentation
- 45 • lecture on ipython notebook, binder, signal pro-
- 46 cessing tutorials
- 47 • relevant LIGO instrumentation papers
- 48 • an introduction to the parameter estimation
- 49 pipeline LALInference
- 50 • lalinfmcmc, a program which I ran while varying
- 51 only the number of effective runs (neff) from 5000
- 52 through 500 (discovered a hard cut off at neff2000)

- 53 • condor submit files and a dag files which I created
- 54 by hand
- 55 • python plots of lalinfmcmc results

56 My ipython notebook is uploaded on my GitHub:
57 <https://github.com/mmcintosh27/LIGO> and Figure 1
58 shows the one of plots I made of lalinfmcmc at various
59 neff to determine if the parameter estimates varied as a
60 function of neff, but it doesn't look like they do.

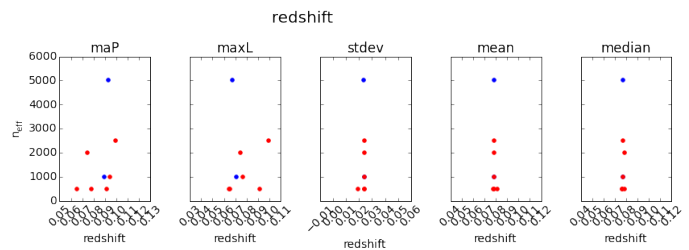

61 FIG. 1.— More information about the runs are on
62 [https://ldas-jobs.ligo.caltech.edu/~melissa.mcintosh/](https://ldas-jobs.ligo.caltech.edu/~melissa.mcintosh/neff1000/posplots.html)
neff1000/posplots.html and urls of the like.

63 My goals for next month include finishing my literature
64 review, selecting my calibration focus, understanding the
65 calibration uncertainty to a greater extent, learning how
66 to modify current calibration models, developing meth-
67 ods to propagate calibration uncertainty for astrophys-
68 ical and precision-GR parameters, quantitatively evaluat-
69 ing systematic and statistical errors on these parameters,
70 and estimating the contributions from the calibration un-
71 certainties in impacting these errors.

72 **What are the challenges and problems you have**
73 **met so far and what challenges and problems do**
74 **you anticipate?**

75 Running lalinfmcmc seems to be done with an “.ini” file,
76 but system updates has caused the file to not be func-
77 tional for the past three weeks. In its place I have been
78 using the command line to run lalinfmcmc and creating
79 sub files for condor and dag files by hand. This is not
80 as straightforward but also has the benefit of a lower-
81 level understanding of the function of the .ini file. In the
82 upcoming weeks I anticipate the difficulty of “stacking”
83 injected signals and understanding ways of testing GR.

84 **What resources will you require?**

85 A patient mentor and perhaps some tech support.

86 The rest of this document is a start on my final paper.

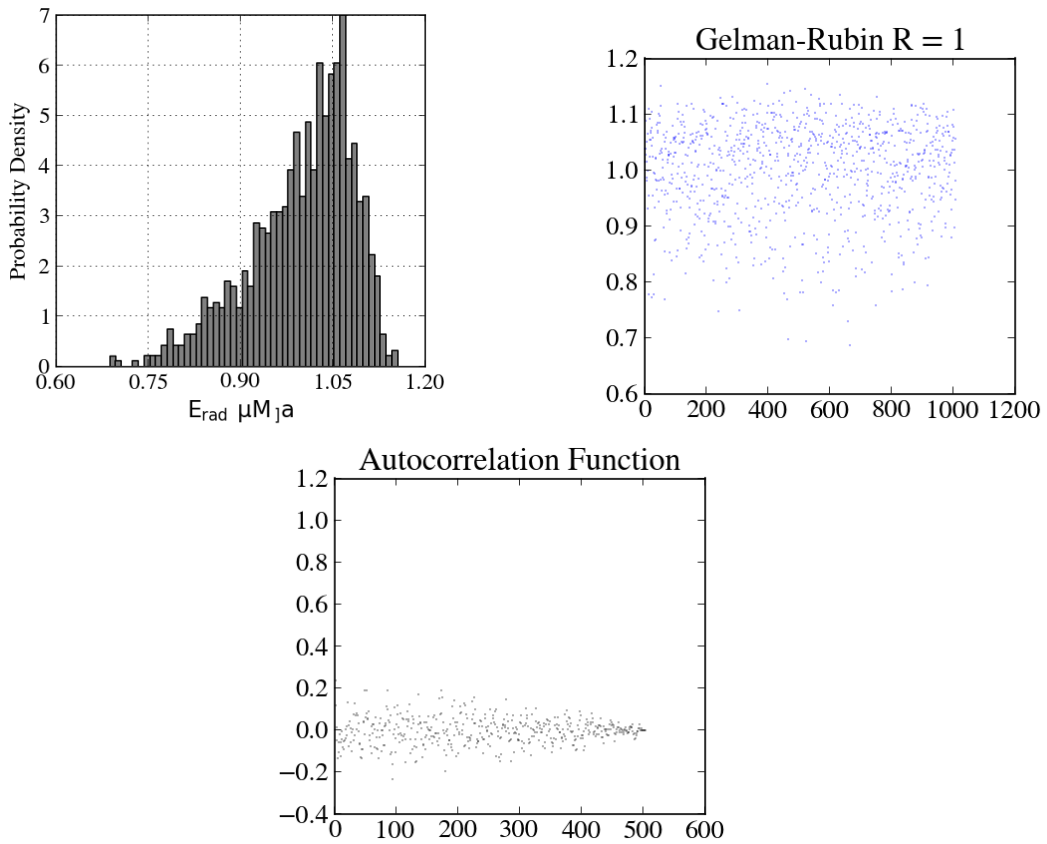

FIG. 2.— Output from LALInference_mcmc for $N_{\text{eff}} = 1000$. This project will investigate how calibration errors impact the probability distributions of parameter estimations like in the figure on the left.

II. INTRODUCTION

In 1915, Einstein published his General Theory of Relativity (GR). This theory and his following papers predicted the existence of gravitational waves (GWs), or oscillations in the gravitational field caused by the acceleration of massive bodies. In 1993, a Nobel Prize went to Hulse and Taylor [8] who discovered a pulsar system losing energy at the same rate as predicted by GW emission and thus implying the existence of GWs. Then in 2015, a direct detection of a GW occurred. GW150914, identified as a result of a binary black hole merger, was observed with the Advanced Laser Interferometer Gravitational Wave Observatory (aLIGO) detector network [2]. With this detection, the field of direct GW observations emerged.

GWs allow us to observe strong-field dynamics of space-time and astrophysical phenomena inaccessible by electromagnetic radiation. With the direct detection of GWs, experiments to test GR in large velocity, highly dynamical, and strong-field gravity regimes can be conducted. Because GWs cause extremely small perturbations in aLIGO (on the order of 4×10^{-20} m [2]) the sensors and signal analyses need to be precise. Characterizing and reducing uncertainties in aLIGO data allows us to reclaim as much physical information from the GW signal as possible.

The goals of this work are to (1) describe both the calibration methods used for aLIGO and their uncertainties and (2) estimate the effects of this calibration uncertainty on precision tests of GR. The layout of this paper is as follows. First, we specify our focus on calibration errors (CEs) in Section III. Next, we summarize how aLIGO detects GW and how these CEs impact the instrument in IV. In V, we describe the differential arm length (DARM) closed feedback loop transfer function, which contains the GW wave signals and CEs for aLIGO. Then in VI, we outline astrophysical and calibration parameter estimation using the parameter estimation pipeline `LALInference` [18]. We relate previous research on the impact of CEs on this parameter estimation method in VII. In VIII and IX, we describe the software signal injections used to mimic GR and non-GR conforming GW signals and their use in `TIGER` [5], a data analysis pipeline for testing the strong-field dynamics of GR with GW signals. Finally, we recover the parameters used to generate the software signal injections with both a constant CE model, a spline interpolation CE model, and a frequency dependent CE model. We present the effectiveness of the CE models in recovering a particular GW ringdown parameter and discuss the impact the models would have on recovering astrophysical parameters and other precision GR test parameters in Sections X and XI.

III. CALIBRATION ERRORS

The two sources of uncertainty in any instrument are statistical and systematic uncertainty. Though statistical uncertainty, a zero-mean Gaussian distribution measurement variation, is unavoidable, it can be reduced by taking additional observations. Systematic uncertainty is relatively avoidable and cannot be reduced by additional measurements unless GR is assumed to hold true. Systematic uncertainty stems from an incorrect charac-

terization of a detector and causes calibration errors. For aLIGO, careful calibration has to be maintained to accurately associate the frequency response of the detector with the motion of aLIGO’s optics and consequently reduce systematic error. These calibration errors are the focus of this project.

Calibration errors (CEs) are errors that pertain to the conversion of instrumental readout to GW strain and are contained in the differential arm length readout (DARM) of aLIGO. CEs can affect detection rates and parameter estimations; here we are concerned with parameter estimation. Current CEs for aLIGO are estimated as an overall constant in wave amplitude and phase or with spline-fitting, but a new, frequency dependent estimation method also is discussed here. Previous works that have studied calibration error analysis for aLIGO include [15, 20].

This work uses a Bayesian approach to quantify potential CE effects on signal injections which mimic both GR and non-GR conforming GWs. It is possible that the CEs will blur our ability to distinguish between the two; we also investigate if our frequency dependent method of characterizing CEs will allow us to distinguish the GR and non-GR conforming signal injections. Though the few individual GW signals detected so far have had no statistically significant disagreement with GR and their statistical error exceeds their systematic error, the aLIGO detectors are not yet at their design sensitivities, louder GW sources may yet be detected, and the potential to combine or “stack” GW observations as in [16] to increase sensitivity all encourage this work [4].

IV. HOW LIGO DETECTS GWS

aLIGO is a complex and cutting edge instrument; it consists of a modified Michelson interferometer with Fabry-Perot arms that uses power-recycling mirrors and resonant sideband extraction which allow it to measure minuscule phase propagation differences via the Pound-Drever-Hall technique [7, 10, 12]. However, we follow [20] in this analysis and reduce the entire instrument to a sensor with a single degree of freedom: differential arm length (DARM) perturbations. When a GW passes through aLIGO, the space in one direction stretches while the space in the other direction contracts; this arm length change/perturbation interrupts the constructive interference of laser light maintained in the arm cavities and some light escapes the arms to a photodetector (see Figure 3). This escaped light generates the signal we analyze to recover the GW parameters.

Figure 4 illustrates a waveform that aLIGO might detect. From the amplitude and phase of this waveform, we can extract astrophysical parameters such as those listed in Table 1.

In this work, we focus on a single-parameter analysis in the merger-ringdown regime to test GR using multiple events, rather than characterizing a particular GW event. Subsequently, we marginalize over the parameters listed in Table 1.

V. DARM FEEDBACK CONTROL LOOP

The external differential arm length change, ΔL_{ext} , is related to the GW amplitude, called the “strain:”

$$h(f; t) = \frac{\Delta L_{ext}}{\langle L \rangle} \quad (1)$$

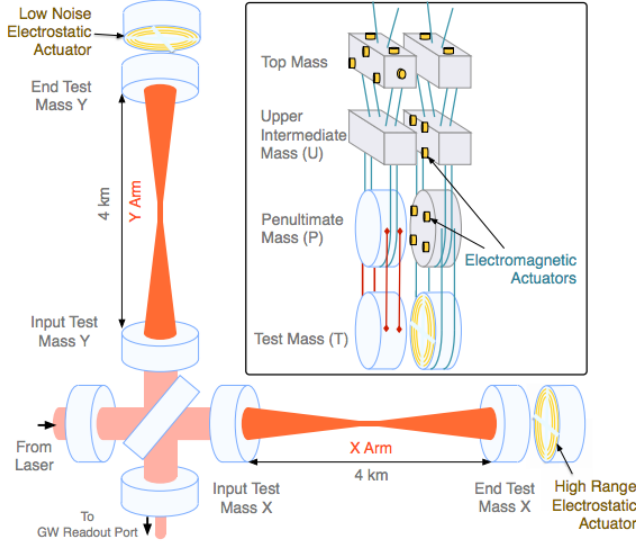

FIG. 3.— This diagram of aLIGO is from [20]. The arm cavities are contained between the reflective test masses. These test masses are suspended from a quadruple pendulum system and are adjusted spatially by an actuating system displayed in the upper right corner. These adjustments allow resonance to be maintained in the arm cavities. When resonance is disrupted by a GW passing through, stretching one arm cavity and shrinking the other, resonance is disrupted and some light escapes to the GW Readout Port at the bottom of the figure.

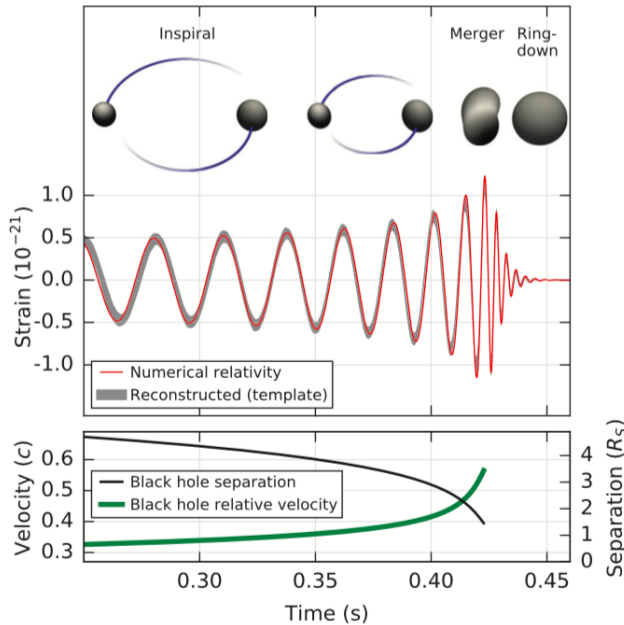

FIG. 4.— A figure illustrating an inspiral-merger-ringdown of a compact binary system from [2]. According to GR, two objects in orbit will slowly spiral inwards due to a loss of energy and angular momentum via GWs. The frequency and amplitude of the emitted GWs increases as the orbital distance between the objects shrink. When the objects finally merge they can radiate GWs as a superposition of quasinormal ringdown modes. One mode will eventually dominate with an exponentially damped, constant frequency wave [4]. We observe this as a lower frequency inspiral phase, a post-merger peak at some fixed frequency, and then a higher frequency ringdown. In this work we investigate the differences due to non-GR conformity as described in a parameter pertaining to the ringdown of the GW.

TABLE 1
PARAMETERS USED TO CHARACTERIZE A GW DETECTION. TAKEN IN PART FROM [4]

M/M_\odot	Detector-frame total mass
\mathcal{M}/M_\odot	Detector-frame chirp mass
m_1/M_\odot	Detector-frame primary mass
m_2/M_\odot	Detector-frame secondary mass
M_f/M_\odot	Detector-frame final mass
M^{source}/M_\odot	Source-frame total mass
$\mathcal{M}^{source}/M_\odot$	Source-frame chirp mass
m_1^{source}/M_\odot	Source-frame primary mass
m_2^{source}/M_\odot	Source-frame secondary mass
M_f^{source}/M_\odot	Source-frame final mass
q	Mass ratio
χ_{eff}	Effective inspiral spin parameter
a_1	Dimensionless primary spin magnitude
a_2	Dimensionless secondary spin magnitude
a_f	Final spin
D_L/Mpc	Luminosity Distance
z	Source redshift
$\ln \mathcal{B}_s/n$	Log Bayes factor

where $\langle L \rangle \approx 4000m$ is the arm cavity length gain of aLIGO. aLIGO's photodetector does not directly measure ΔL_{ext} but rather the current generated from the amount of light that has escaped from the arm cavities, d_{err} (the DARM error signal). ΔL_{ext} must be reconstructed from $d_{err}(f)$.

$d_{err}(f)$ is measured continuously in a closed feedback loop. The purpose of this feedback loop (see the reduced block schematic in Figure 5) is to recenter the mirrors used in aLIGO after the arms have been perturbed by a GW or noise so that the constructive interference/resonance of the laser is maintained. This allows the instrument to measure the next arm length differential as quickly as possible.

We can reconstruct $h(f;t)$ from the DARM control loop (see Figure 5):

$$\langle L \rangle \approx h(f;t) - \Delta L_{ctrl} = \Delta L_{res} \quad (2)$$

$$h(f;t) = \frac{1}{\langle L \rangle} \left(\frac{1}{C(f;t)} D(f) d_{err} + A(f;t) d_{ctrl} \right) \quad (3)$$

$$h(f;t) = \frac{1}{\langle L \rangle} \left(\frac{1 + G(f;t)}{C(f;t)} d_{err} \right) \quad (4)$$

$$h(f;t) = \frac{1}{\langle L \rangle} R_e(f;t) d_{err} \quad (5)$$

$$\text{where } R_e(f;t) = \frac{1 + A(f;t)D(f)C(f;t)}{C(f;t)} \quad (6)$$

$$= \frac{1 + G(f;t)}{C(f;t)} \quad (7)$$

Here, $C(f;t)$ is the transfer function of the arm cavity or the sensing function, $D(f)$ is a digital filter, and $A(f;t)$ is the actuation function that corrects mirror position. d_{ctrl} is the signal sent to the actuators describing how to move the test masses to recover resonance, ΔL_{ctrl} is the length perturbation the actuation function applies to the test masses, and ΔL_{res} is any residual length change the actuation function happens to not correct. We take the various transfer functions into

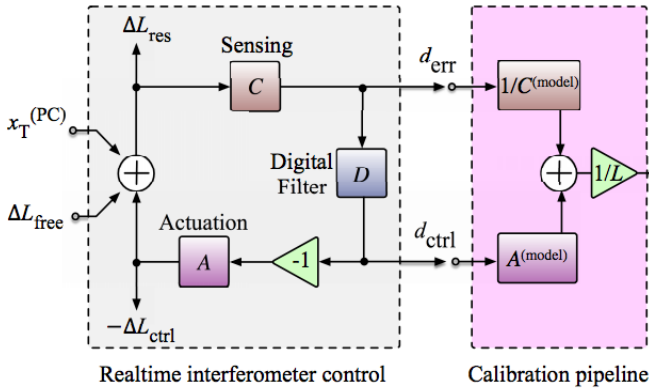

FIG. 5.— A block diagram of the DARM feedback control servo from [20]. This schematic shows that aLIGO’s output is dependent on the performance of the feedback loop. Each component of the feedback loop is described by a transfer function and the uncertainty on the overall loop transfer function yields the CEs on the GW strain detection. The transfer functions of all of the components in the feedback loop are necessary to reconstruct the GW signal. The subsystems are described more thoroughly in [15, 20].

largest systematic errors at frequencies above the unity gain frequency (40 Hz and 56 Hz for H1 and L1, respectively [15]). The coupled cavity pole frequency $f_{cc}(t)$ depends on the reflectivities of the interferometer optics and has a time dependency due to cavity length and alignment changes [14]. This changes the shape of the sensing function at frequencies close to the nominal coupled cavity pole frequencies. At high frequencies, $\kappa_c(t)$ and $f_{cc}(t)$ contribute systematic errors in the magnitude of ΔL_{ext} [17].

V.II. Actuation Function $A(f; t)$

The actuation function describes the physical actuators that spatially adjust the test masses hung in quadrature (see Figure 3). The test mass stage are labeled as follows: Top, Upper Intermediate, Penultimate, and Test. All except for the top stage are actuated upon and so contribute a term to the actuation function. The Upper-Intermediate and Penultimate masses have Optical Sensor and Electromagnetic (OSEM) actuators while the test mass, the mass that the laser light hits, has an ElectroStatic Drive (ESD) actuator. The ESD allows for finer spatial adjustments but can build up charge from residual gas via ion vacuum pumps in aLIGO. Consequently, its strength changes with time.

$$A(f; t) = [\kappa_T(t)A_T(f) + \kappa_P(t)A_P(f) + \kappa_U(t)A_U(f)] e^{-2\pi i f \tau_A} \quad (9)$$

$\kappa_T(t)$:	ESD actuation strength
$\kappa_P(t)$:	OSEM actuation strength
$A_T(f)$:	Test mass actuation function
$A_P(f)$:	Penultimate mass actuation function
$A_U(f)$:	Upper-Intermediate mass actuation function
τ_A :	computational time delay in digital-to-analog conversion

Equation 7 indicates $R_e(f; t) \approx A(f; t)D(f)$ when $|G| \gg 1$. $A_T(f)$ is the dominate term in $A(f; t)$ for frequencies greater than 20 Hz; the largest systematic errors contained in $A(f; t)$ ($\pm 15\%$) are due to variations in the actuation strength of the ESD from 20 – 50 Hz [17].

V.III. Full Parametrization of the Response Function and Real-Time Calibration Measures

With our parameters from $C(f; t)$ and $A(f; t)$, we can rewrite our actuation function beginning with equation 7 and dropping the time delays as:

$$R_e(f; t) = \frac{1 + A(f; t)D(f)C(f; t)}{C(f; t)} \quad (10)$$

$$R_e(f; t) = \frac{1}{C(f; t)} + D(f)A(f; t) \quad (11)$$

$$R_e(f; t) = \left(\frac{\kappa_C(t)C_R(f)}{1 + if/f_{CC}(t)} \right) + D(f)(\kappa_T(t)A_T(f) + \kappa_P(t)A_P(f) + \kappa_U(t)A_U(f)) \quad (12)$$

The time dependent parameters ($\kappa_T(t), \kappa_P(t), \kappa_C(t), f_{CC}(t)$) are monitored for variation using intentional injections at a single frequency

$G(f; t) = C(f; t)D(f)A(f; t)$, the DARM open loop gain. We further rearrange this equation into a response function, $R_e(f; t)$, which lets us estimate uncertainty more easily. $D(f)$ is known precisely, so the uncertainty in our GW strain, $\sigma_h(f; t)$, is dominated by the uncertainty in $R_e(f; t)$: $\sigma_R(f; t)$. Equation 7 is derived and its components described more thoroughly in [20, 15]. More complex calibration loop treatments are given in [1, 13].

In equation 5, $R_e(f; t)$ gives the theoretical or exact response function, but the measured length function, $R_m(f; t)$, includes CEs from the sensing $C(f; t)$ and actuation $A(f; t)$ functions as well as the slow, time-dependent drift in these functions. Because detectors are noisy, drift with time, and can glitch, $R_e(f; t)$ and $R_m(f; t)$ can differ greatly. This leads to systematic errors in GW strain reconstruction.

The frequency dependent and time dependent parameters of $R(f; t)$ are what impact the response function uncertainty, $\sigma_R(f; t)$. We examine these parameters for $C(f; t)$ and $A(f; t)$.

V.I. Sensing Function, $C(f; t)$

The sensing function “senses” GW strain. It represents the interferometer optical plant and is approximated by a coupled-cavity single pole function [9]:

$$C(f; t) = \frac{\kappa_C(t)C_R(f)}{1 + if/f_{CC}(t)} e^{-2\pi i f \tau_C} \quad (8)$$

$\kappa_C(t)$:	optical gain
$f_{CC}(t)$:	coupled cavity pole
$C_R(f)$:	“sensing residual” after cavity pole is divided out
τ_C :	sensing function time delay

The optical gain $\kappa_C(t)$ depends on the laser power in the optical arm cavities and has a time dependent scalar gain factor. Equation 7 indicates $R_e(f; t) \approx 1/C(f; t)$ when $|G| \ll 1$. Changes in the optical gain produce the

(called calibration lines) into the DARM spectrum throughout an observation run (see Table 2). The calibration lines reveal any short-term gain fluctuations in optical plant or actuation strengths.

TABLE 2

CALIBRATION LINE TABLE RECREATED FROM [17]. LINES 1-3 ARE USED TO ESTIMATE κ_T AND κ_P AND LINE 4 FOR κ_C AND f_c FOR THE LIGO HANFORD (H1) AND LIGO LIVINGSTON (L1) DETECTORS.

#	Signal	Freq. H1.	(Hz) L1	Line Purpose
1	x_T	35.9	35.3	ESD actuation strength
2	ΔL_{pcal}	36.7	34.7	DARM actuation
3	x_{ctrl}	37.3	33.7	Penultimate & Upper-Intermediate actuation strengths
4	ΔL_{pcal}	331.9	331.3	Optical gain and coupled cavity pole frequency

The frequency dependent parameters in our response function ($A_U(f)$, $A_P(f)$, $A_T(f)$, $C_R(f)$) are measured between observation runs using swept sine calibration; a sine wave displacement signal is applied to a test mass while the interferometer is locked. Then, the frequency is slowly swept over the GW detection band and the error signal is measured as a function of the displacement. This yields the closed loop transfer function equation. During observation runs, the frequency dependent parameters are measured a few times per run using wide-band pseudo-random signals with amplitudes below the noise level. The disturbances created from this are small and distributed over the whole gravitational wave band. While having the advantage of not impacting any GW signal observations, below noise-level calibration signals have the disadvantage of needing a longer integration time to extract. This results in obtaining only a few frequency calibration signals per observation run. It is assumed that the frequency dependence of the control loop will not vary in between these calibration signal extractions [13].

Because this does not always hold true, the interpreted GW strain will be different from the true GW strain in both phase and amplitude. As discussed in Section IV, this affects both the precision measurement of astrophysical parameters like masses, sky location, distance, inclination, and orientation and also the measurement of universal parameters like those that describe variations from GR. To decrease the difference between the measured length function and the exact length function, we seek to better characterize aLIGO's CEs through Bayesian parameter estimation.

VI. BAYESIAN PARAMETER ESTIMATION WITH LALINFERENCE_MCMC

Using the parameter estimation pipeline `LALInference` [18], we compare a parametrized GW waveform model to the detected strain signal. Figure 4 shows the model used for GW150914. This matched filtering technique using template banks, further described in [6], is an accurate and time sensitive method to identify potential gravitational waves.

Using `LALInference`'s results, we can construct probability density functions (PDFs) for each of the parameters in the GW detection. To be explicit, we begin with

Bayes' theorem; the probability that a parameter, θ , is the correct value given some data, x , is equal to the probability of getting the data given the parameter times the probability that the parameter is the correct value, and divided by the evidence of the data:

$$P(\theta|x) = \frac{P(x|\theta) \times P(\theta)}{P(x)} \quad (13)$$

Here, $P(\theta|x)$ is the posterior probability, $P(x|\theta)$ is the likelihood, $P(\theta)$ the prior, and $P(x)$ the evidence.

We can then express the probability that the strain data $x(f)$ came from an astrophysical system with parameter θ with the log-likelihood, $\ln P(x|\theta)$:

$$\ln P(x|\theta) = -1/2 \int_0^\infty \frac{|h(f, \theta) - x(f)|^2}{S_{nn}(f)} \quad (14)$$

where $x(f)$ is the strain data from the detector, $h(f, \theta)$ is the GR prediction for the strain with parameter θ , and $S_{nn}(f)$ is the power spectral density of the detector's strain noise.

We can update this probability as more data becomes available. We can "stack" GW observations like so:

$$\begin{aligned} P(\theta|x, y) &= \frac{P(x, y|\theta) \times P(\theta)}{P(x, y)} \\ &= \frac{P(y|\theta, x) \times P(\theta|x)}{P(x, y)} \quad \text{Substitute in Eqn. 13} \\ &= \frac{P(y|\theta) \times P(x|\theta) \times P(\theta)}{P(x)P(y)} \end{aligned} \quad (15)$$

Because GWs are uncorrelated the probability of y does not depend on x

where $P(\theta|x, y)$ is the posterior probability that θ is the correct value given that x , our data or a GW detection, and y , new data or another GW detection, exist. The normalization constants of these models are typically ignored in favor of simply comparing two competing models by taking the ratio (called the odds ratio) of posterior probabilities to the evidence/potential GW signal:

$$O_{i,j} = \frac{P(\theta_i|x)}{P(\theta_j|x)} B_{ij} \quad (16)$$

where θ_i is some parameter model and is compared to another parameter model, θ_j . The Bayes factor or evidence ratio, B_{ij} , is the ratio of likelihoods between the models. It is often used as a statistic to describe confidence in the correctness of a model or to rank competing hypotheses given the observed data. From equation 15 we see that as we amass new GW detections we update the probability by multiplying the detections together. For an arbitrary number of detections, the probability of the parameter is then given by:

$$P(\theta|x_i) \propto \left[\prod_i P(x_i|\theta) \right] \times P(\theta) \quad (17)$$

Stacking GW strain signals in this way can constrain parameter estimation better than a single detection can. However, Bayesian inference tends to be computationally expensive, due to a large number of parameters (15 for

the most simple compact binary merger models, excluding instrumental and calibration parameters, see Table 1), complex multi-modal likelihood functions, and the computationally costly process of generating the model waveforms [18]. As a result, stochastic sampling techniques, like Markov Chain Monte Carlo (MCMC), Nested Sampling, and MultiNest/BAMBI, have been explored and developed for Bayesian inference for GW data and have been packaged into `LALInference` to speed up the process. This work specifically uses the MCMC routine `LALInference_mcmc`.

In short, `LALInference_mcmc` subtracts the input GW model from the potential GW signal strain and compares the result with Gaussian white noise [18]. It uses a MCMC to step through the 15+ parameter space, using Bayesian inference to calculate the likelihood of the subtracted signal to be Gaussian white noise as a function of the step’s parameter values. `LALInference_mcmc` then takes the most probable template and outputs the PDFs of those parameters. With the PDFs we can compute parameter expectations and confidence intervals.

VII. IMPACT OF CALIBRATION ERROR MODELS ON BAYESIAN PARAMETER ESTIMATION

CEs will introduce bias in the posterior distributions of the measured parameters. In this section we discuss the impact that a constant, spline-fitted, or a frequency dependent calibration error model have on our parameter estimations.

Previous studies [19] have designated an “effect size” statistic to measure the shift in the median of a parameter due to calibration errors and weight it by the standard deviation:

$$\sigma_{\theta} \equiv \frac{\hat{\theta}_{cal} - \hat{\theta}_{nocal}}{\sigma_{\theta, nocal}} \quad (18)$$

VII.I. Constant CE Model

The constant CE Model is the most basic model. It allows for two additional parameters that specify a constant shift in amplitude and phase.

VII.II. Spline Fit CE Model

Spline interpolation is the current CE Model for aLIGO.

VII.III. Frequency Dependent CE Model

A frequency dependent CE model is more realistic and predicted to increase precision of parameter estimation.

VIII. SOFTWARE INJECTIONS

Though up to 100’s of observations per year are expected by the time LIGO operates at design sensitivity [3], only two GW detections have been published as of the time of this paper. For now, we use simulated signals injected by software instead of real GW signals. We construct these injections to share a common non-GR parameter for us to constrain in hopes that the technique can be used on real data when more GW detections are available. Additionally, we can construct confidence intervals from these PDFs as a function of the number of injections/detections. This will allow us to estimate how

many injections/detections are required to constrain the non-GR parameter in future studies.

GW waveform models are based off of an analytical inspiral-merger-ringdown (IMR) model (see Figure 4) and usually calibrated against waveforms from direct numerical integration of the Einstein equations [4]. We use injections generated from `lalapps_inspinj`, part of the `LaLapps Suite` [11].

IX. TIGER PIPELINE

TIGER (Test Infrastructure for GEneral Relativity) is a data analysis pipeline for model-independent testing the strong-field dynamics of general relativity with GW signals [5]. It relies on Bayesian model selection to combine information from multiple observations. It then compares the stacked data evidence between two hypotheses: a GW waveform model consistent with GR, H_{GR} , and a model with parametrized deformations of the GW waveform model, H_{modGR} , as given by additional parameters. TIGER uses an odds ratio to compare these models:

$$O_{GR}^{modGR} \equiv \frac{P(H_{modGR}|d, I)}{P(H_{GR}|d, I)} \quad (19)$$

where d is the data and I is our prior.

This method is considered model independent because any/all of the additional parameters are allowed to vary from zero (where they agree with GR) such that many different waveforms could be well fit. Each possible waveform is considered a sub-hypothesis and the Bayes factors for all of the sub-hypotheses can be merged into a single odds ratio with which to compare the GR consistent model.

Detector noise can sometimes mimic GR violations. To allay this, the odds ratio should be compared with a noisy background distribution; injecting many simulated GW signals with different astrophysical parameters into data surrounding the GW signal of interest can accomplish this [5]. The odds ratio can then be calculated for many GR consistent injections/noisy background sets. Then, a distribution of the odds ratio for GR consistent GWs can be calculated with an accompanying p-value. From this a threshold can be set for non-GR conforming GW model odds ratios to overcome.

In this work, we focus on a single-parameter analysis in the merger-ringdown regime with a noisy background distribution. We fix all other parameters to be consistent with GR.

X. RESULTS

In this section, we plan to discuss model selection, parameter recovery, and error propagation results. We will then compare the calibration error models and present measurements of their effectiveness in parameter recovery.

XI. CONCLUSION

XII. ACKNOWLEDGMENTS

The authors would like to acknowledge the support of the United States National Science Foundation (NSF) for the construction and operation of aLIGO and its and the Caltech Institute of Technology’s REU LIGO-SURF program.

- [1] J. Abadie, B. P. Abbott, R. Abbott, M. Abernathy, C. Adams, R. Adhikari, P. Ajith, B. Allen, G. Allen, E. Amador Ceron, and et al. Calibration of the LIGO gravitational wave detectors in the fifth science run. *Nuclear Instruments and Methods in Physics Research A*, 624:223–240, December 2010.
- [2] B. P. Abbott, R. Abbott, T. D. Abbott, M. R. Abernathy, F. Acernese, K. Ackley, C. Adams, T. Adams, P. Addesso, R. X. Adhikari, and et al. Observation of Gravitational Waves from a Binary Black Hole Merger. *Physical Review Letters*, 116(6):061102, February 2016.
- [3] B. P. Abbott, R. Abbott, T. D. Abbott, M. R. Abernathy, F. Acernese, K. Ackley, C. Adams, T. Adams, P. Addesso, R. X. Adhikari, and et al. Prospects for Observing and Localizing Gravitational-Wave Transients with Advanced LIGO and Advanced Virgo. *Living Reviews in Relativity*, 19, February 2016.
- [4] B. P. Abbott, R. Abbott, T. D. Abbott, M. R. Abernathy, F. Acernese, K. Ackley, C. Adams, T. Adams, P. Addesso, R. X. Adhikari, and et al. Tests of General Relativity with GW150914. *Physical Review Letters*, 116(22):221101, June 2016.
- [5] M. Agathos, W. Del Pozzo, T. G. F. Li, C. Van Den Broeck, J. Veitch, and S. Vitale. TIGER: A data analysis pipeline for testing the strong-field dynamics of general relativity with gravitational wave signals from coalescing compact binaries. *Phys. Rev. D*, 89(8):082001, April 2014.
- [6] S. Babak, R. Biswas, P. R. Brady, D. A. Brown, K. Cannon, C. D. Capano, J. H. Clayton, T. Cokelaer, J. D. E. Creighton, T. Dent, A. Dietz, S. Fairhurst, N. Fotopoulos, G. González, C. Hanna, I. W. Harry, G. Jones, D. Keppel, D. J. A. McKechnan, L. Pekowsky, S. Privitera, C. Robinson, A. C. Rodriguez, B. S. Sathyaprakash, A. S. Sengupta, M. Vallisneri, R. Vaulin, and A. J. Weinstein. Searching for gravitational waves from binary coalescence. *Phys. Rev. D*, 87(2):024033, January 2013.
- [7] R. W. P. Drever, J. L. Hall, F. V. Kowalski, J. Hough, G. M. Ford, A. J. Munley, and H. Ward. Laser phase and frequency stabilization using an optical resonator. *Applied Physics B*, 31(2):97–105, 1983.
- [8] R. A. Hulse and J. H. Taylor. Discovery of a pulsar in a binary system. *ApJ*, 195:L51–L53, January 1975.
- [9] K. Izumi and D. Sigg. Advanced LIGO: Length Sensing and Control in a Dual Recycled Interferometric Gravitational Wave Antenna. *LIGO Public Technical Document LIGO-P1500277-v3*, 2016.
- [10] J. Mizuno, K.A. Strain, P.G. Nelson, J.M. Chen, R. Schilling, A. Rdiger, W. Winkler, and K. Danzmann. Resonant sideband extraction: a new configuration for interferometric gravitational wave detectors. *Physics Letters A*, 175(5):273 – 276, 1993.
- [11] LIGO Observatory. Inspiral search programs, 2016.
- [12] M. W. Regehr, F. J. Raab, and S. E. Whitcomb. Demonstration of a power-recycled Michelson interferometer with Fabry-Perot arms by frontal modulation. *Optics Letters*, 20:1507–1509, July 1995.
- [13] D. Sigg. Strain Calibration in LIGO. *LIGO Public Technical Document T970101-x0*, 2003.
- [14] A. Staley, D. Martynov, R. Abbott, R X Adhikari, K Arai, S Ballmer, L Barsotti, A F Brooks, R T DeRosa, S Dwyer, A Effler, M Evans, P Fritschel, V V Frolov, C Gray, C J Guido, R Gustafson, M Heintze, D Hoak, K Izumi, K Kawabe, E J King, J S Kissel, K Kokeyama, M Landry, D E McClelland, J Miller, A Mullavey, B OReilly, J G Rollins, J R Sanders, R M S Schofield, D Sigg, B J J Slagmolen, N D Smith-Lefebvre, G Vajente, R L Ward, and C Wipf. Achieving resonance in the advanced ligo gravitational-wave interferometer. *Classical and Quantum Gravity*, 31(24):245010, 2014.
- [15] The LIGO Scientific Collaboration and B. P. Abbott. Calibration of the Advanced LIGO detectors for the discovery of the binary black-hole merger GW150914. *ArXiv e-prints*, February 2016.
- [16] The LIGO Scientific Collaboration, the Virgo Collaboration, B. P. Abbott, R. Abbott, T. D. Abbott, M. R. Abernathy, F. Acernese, K. Ackley, C. Adams, T. Adams, and et al. Binary Black Hole Mergers in the first Advanced LIGO Observing Run. *ArXiv e-prints*, June 2016.
- [17] D. Tuyenbayev, S. Karki, J. Betzwieser, C. Cahillane, E. Goetz, K. Izumi, S. Kandhasamy, J. Kissel, G. Mendell, M. Wade, A. J. Weinstein, and R. L Savage. Improving LIGO calibration accuracy by tracking and compensating for slow temporal variations. *LIGO Document LIGO-190 P1600063*, 2016.
- [18] J. Veitch, V. Raymond, B. Farr, W. Farr, P. Graff, S. Vitale, B. Aylott, K. Blackburn, N. Christensen, M. Coughlin, W. Del Pozzo, F. Feroz, J. Gair, C.-J. Haster, V. Kalogera, T. Littenberg, I. Mandel, R. O’Shaughnessy, M. Pitkin, C. Rodriguez, C. Röver, T. Sidery, R. Smith, M. Van Der Sluys, A. Vecchio, W. Vousden, and L. Wade. Parameter estimation for compact binaries with ground-based gravitational-wave observations using the LALInference software library. *Phys. Rev. D*, 91(4):042003, February 2015.
- [19] S. Vitale, W. Del Pozzo, T. Li, and C. van den Broeck. Effects of calibration errors on parameter estimation for inspiral signals. *LIGO Document LIGO-G1100797*, 2011.
- [20] S. Vitale, W. Del Pozzo, T. G. F. Li, C. Van Den Broeck, I. Mandel, B. Aylott, and J. Veitch. Effect of calibration errors on Bayesian parameter estimation for gravitational wave signals from inspiral binary systems in the advanced detectors era. *Phys. Rev. D*, 85(6):064034, March 2012.