

CHEVRON UV BAFFLE ASSEMBLY

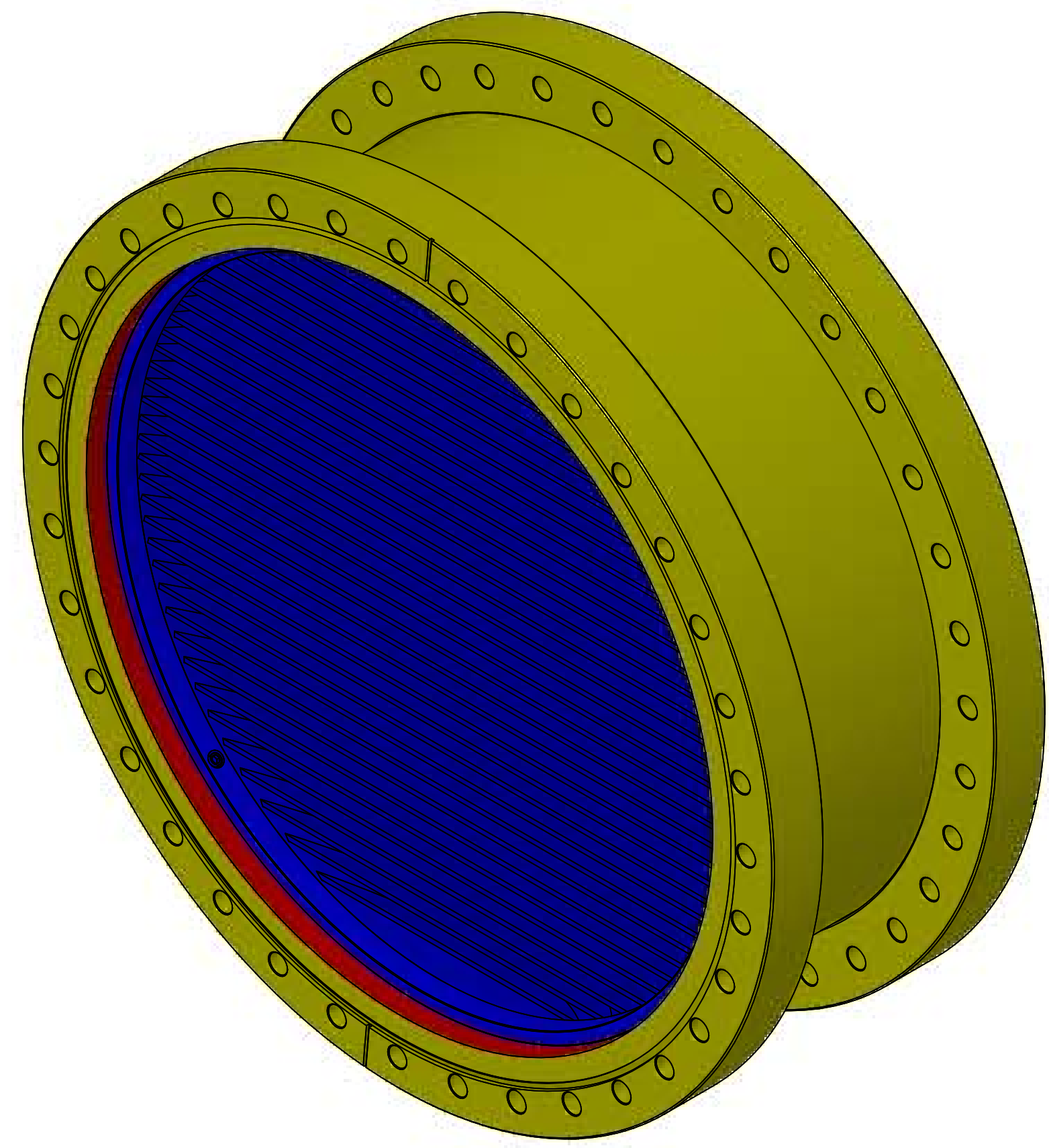

ISO VIEW
(WELDED VERSION)
SEE SHEET 2

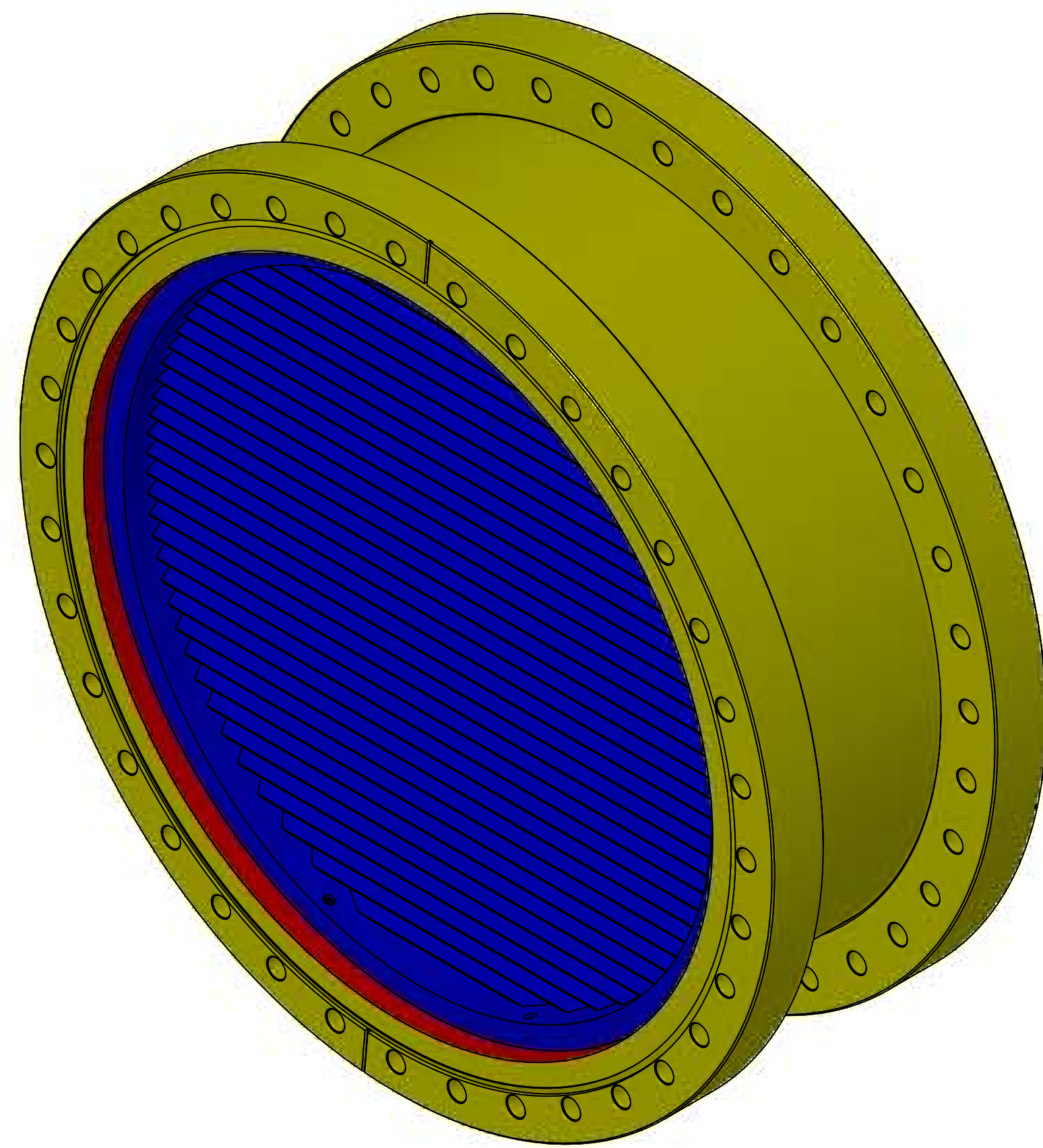

ISO VIEW
(BOLTED VERSION, TYPE 1)
SEE SHEET 3

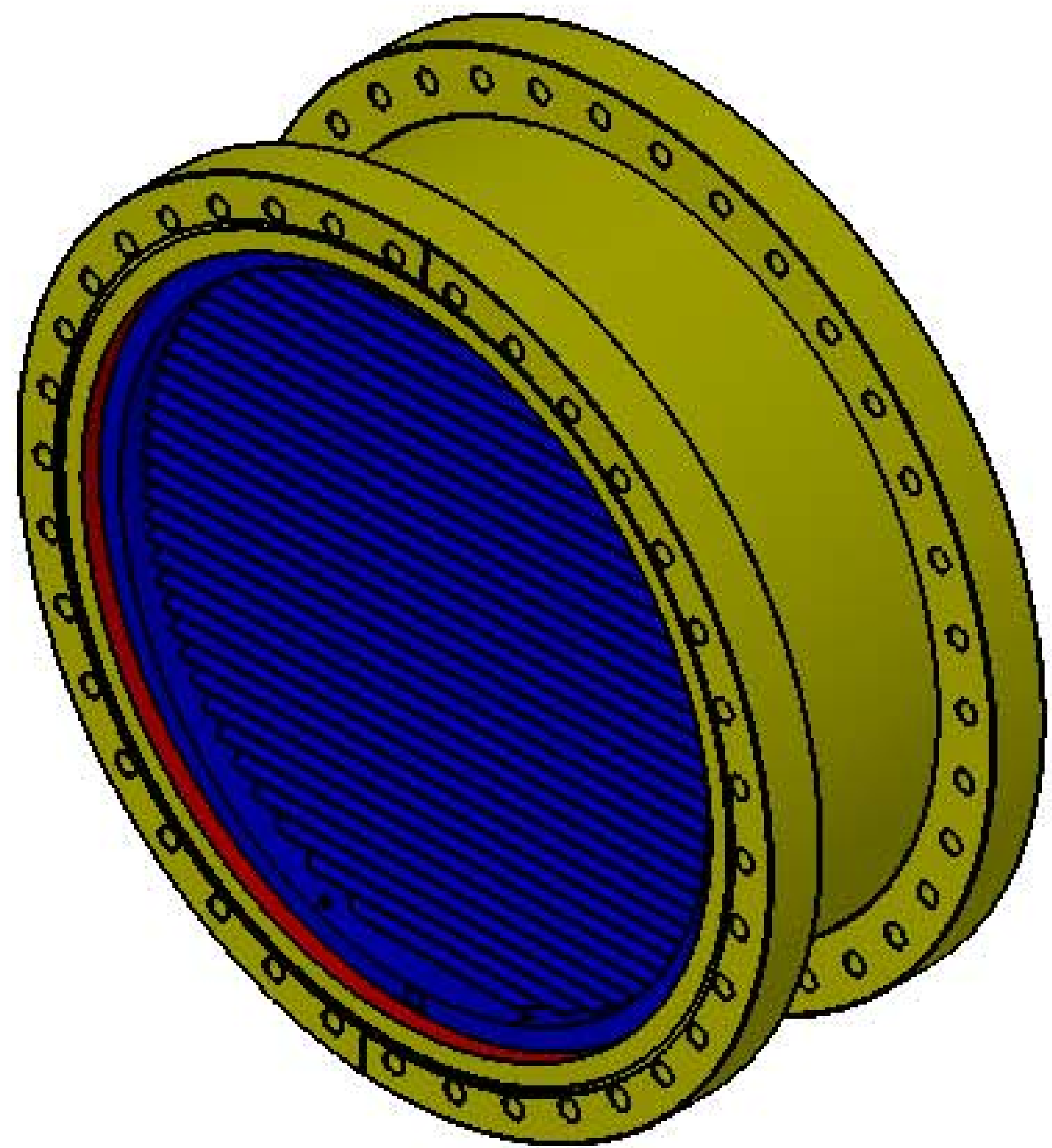

ISO VIEW
(BOLTED VERSION, TYPE 2)
SEE SHEET 4

CUSTOM 16.5" CF, FULL NIPPLE

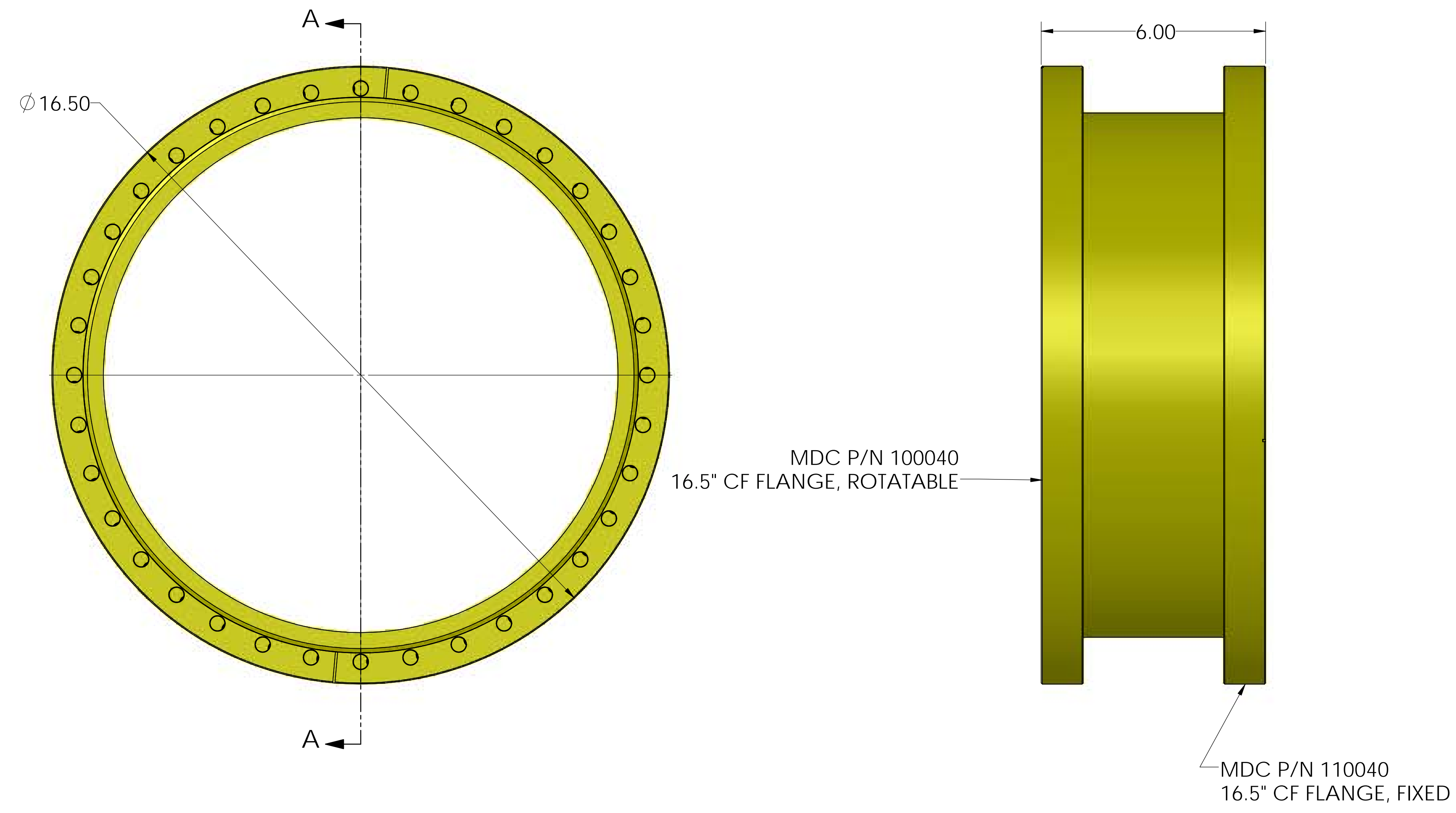

USED WITH: Varian 2500 I/s ION PUMP

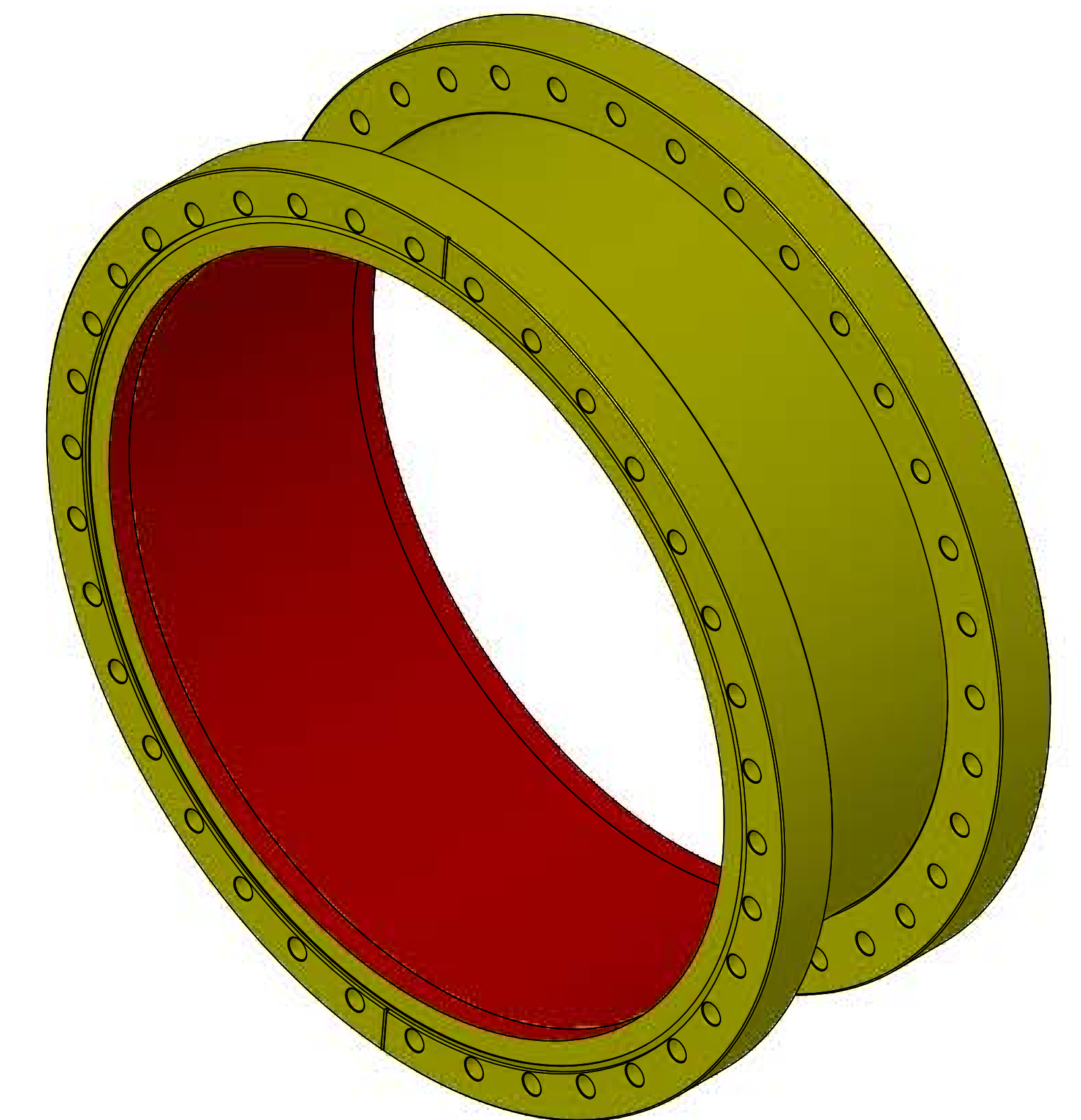
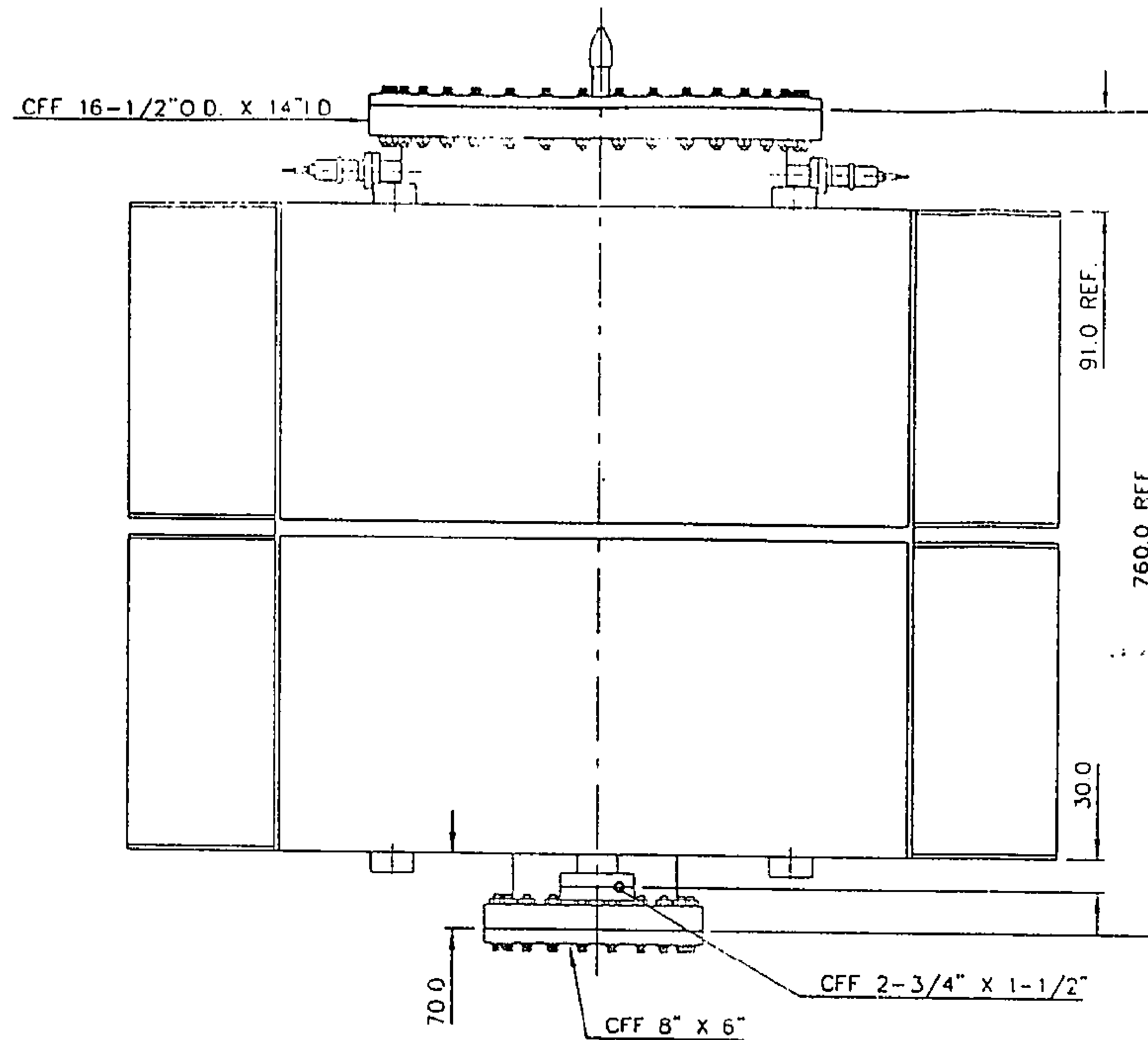

ISO VIEW

Coating Definitions

#	category	color code	name	definition
1	coated area - coating fully compliant with specifications	blue	primary coated area	coated area - coating fully compliant with specifications
2	coated area - relaxed specifications - details to be defined	red	secondary coated area	coated area - relaxed specifications - details to be defined
3	coated, not coated, or partially coated at Acktar's option - no coating requirements	green	no requirement	coated, not coated, or partially coated at Acktar's option - no coating requirements
4	area to be free of any Acktar coating	yellow	uncoated area	area to be free of any Acktar coating

CHEVRON UV BAFFLE ASSEMBLY, WELDED

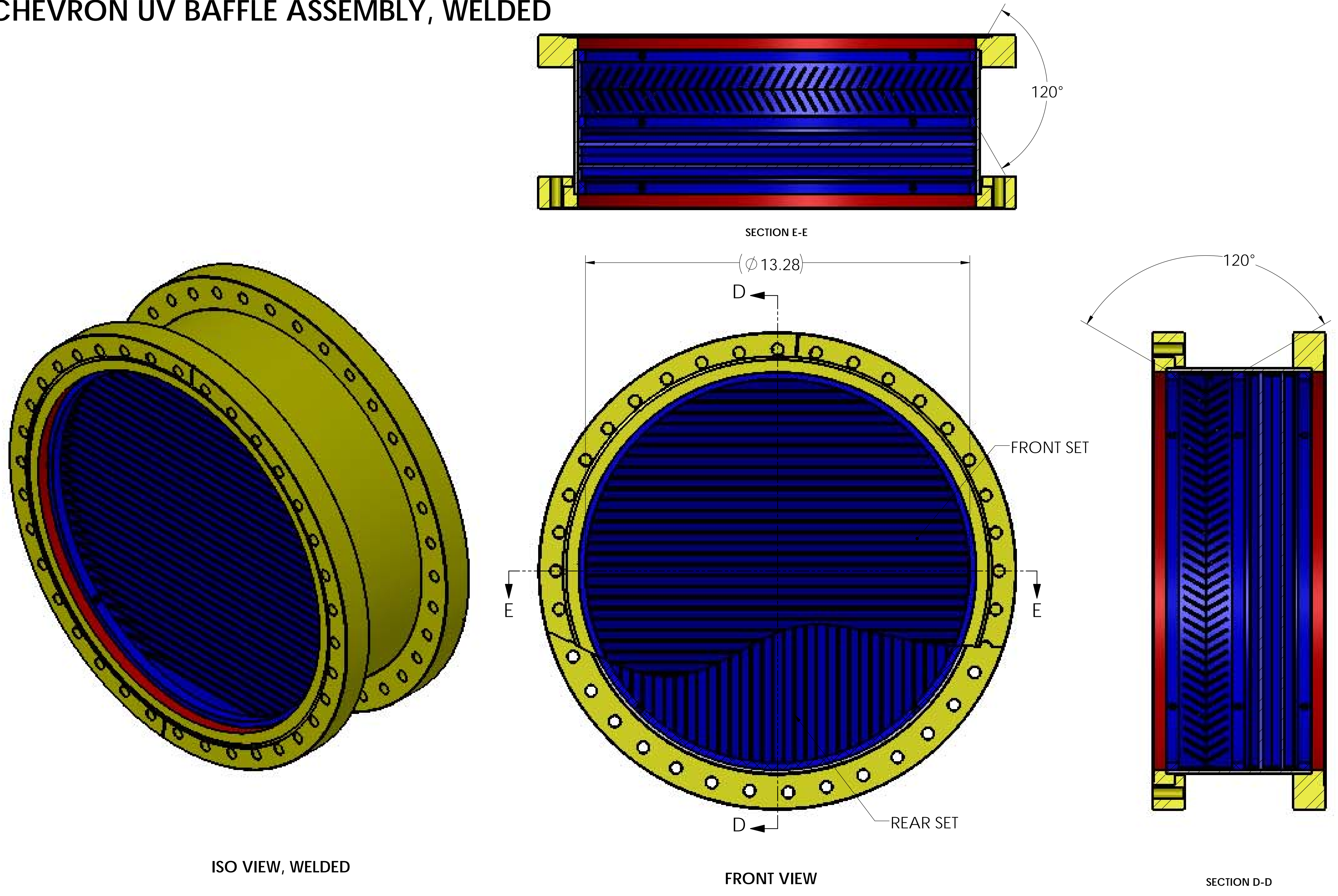

BLADE CELL CONSTRUCTION

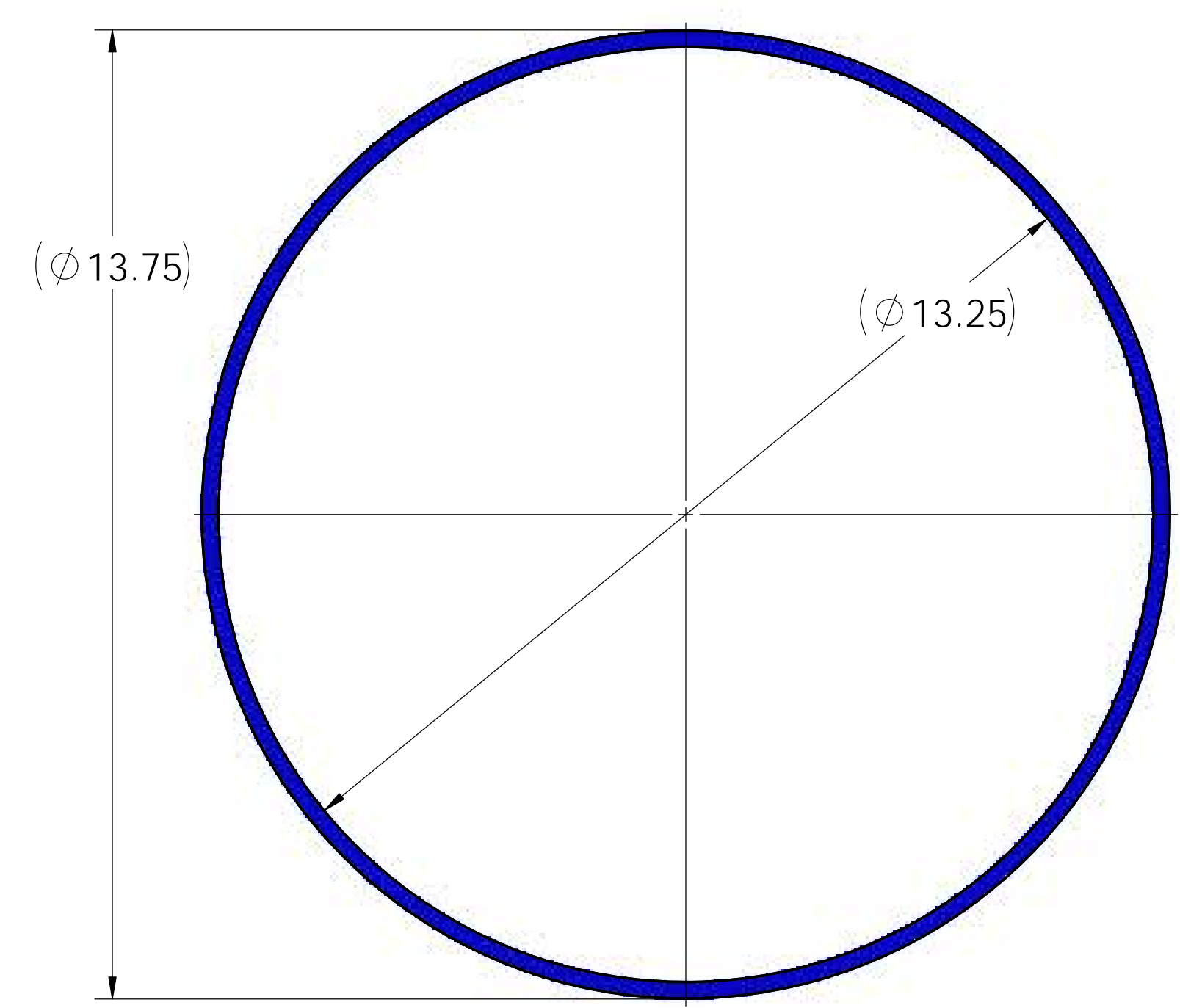
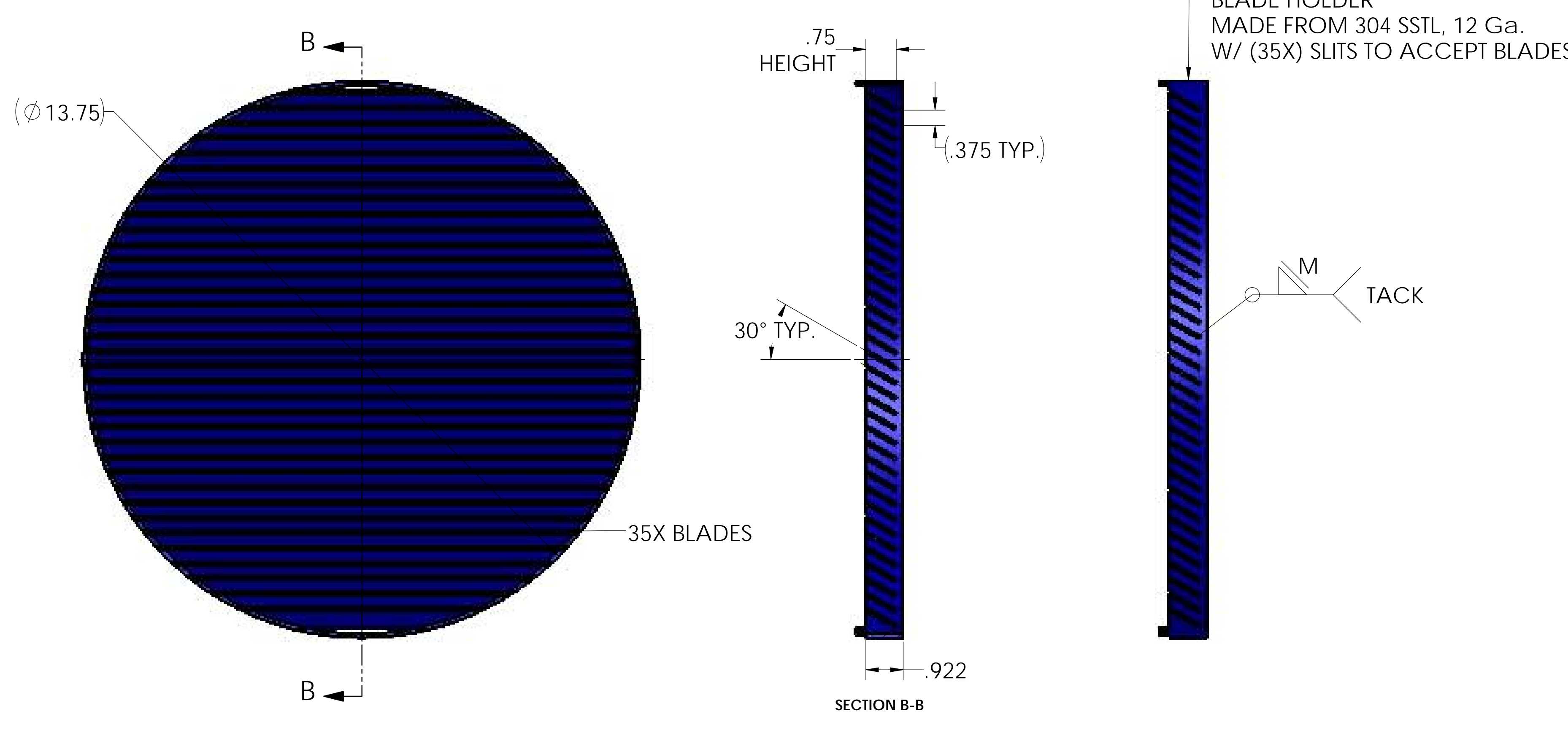

TYP. BLADE DETAIL

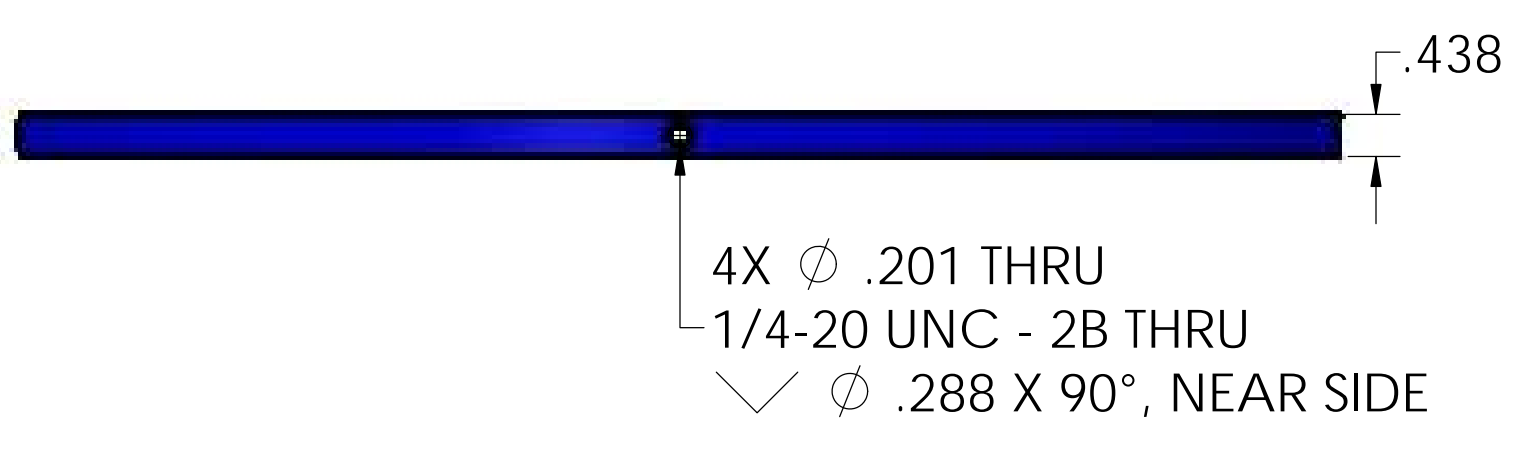
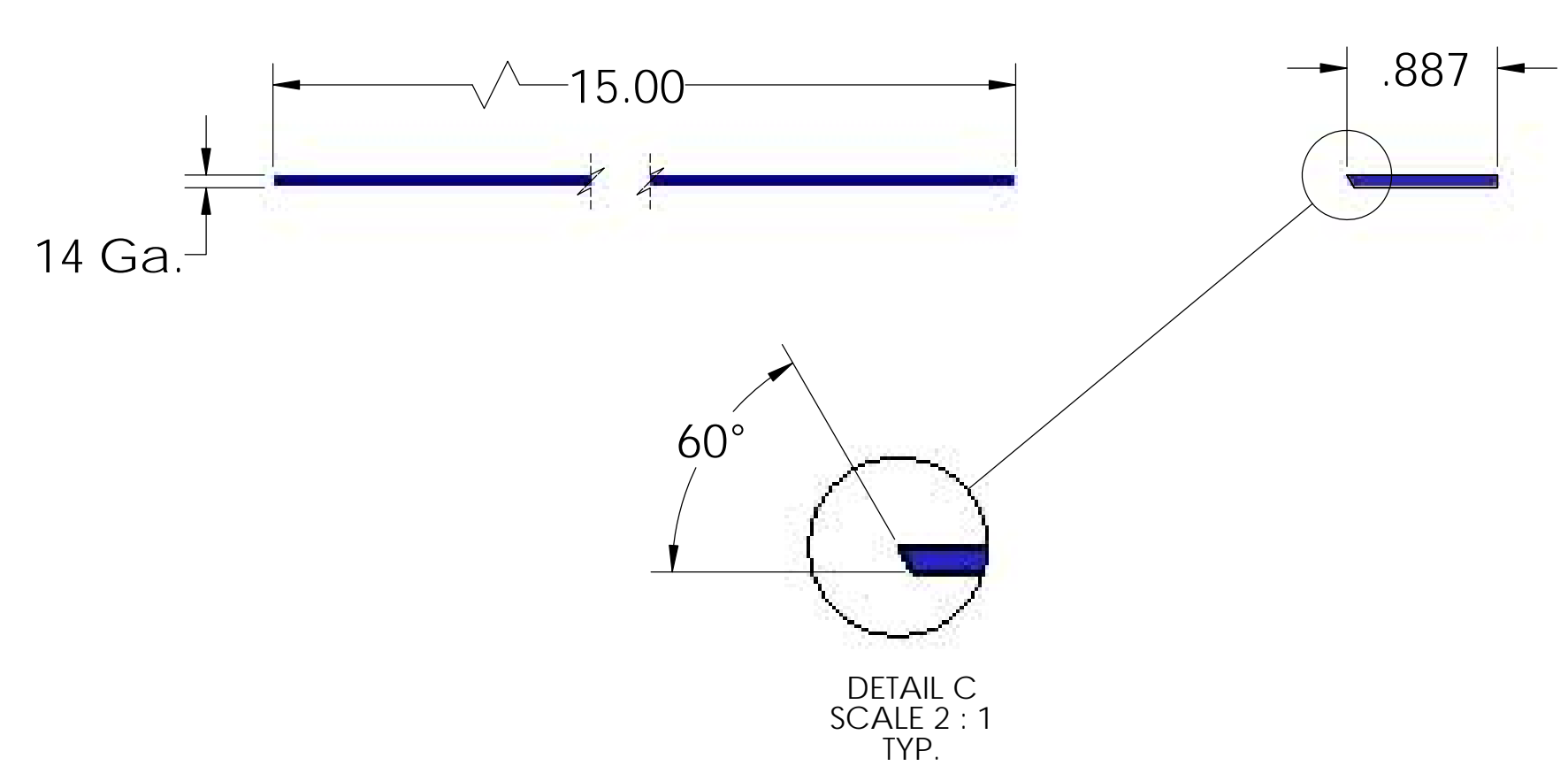

(3X) 6061AL ALLOY RETAINING RING

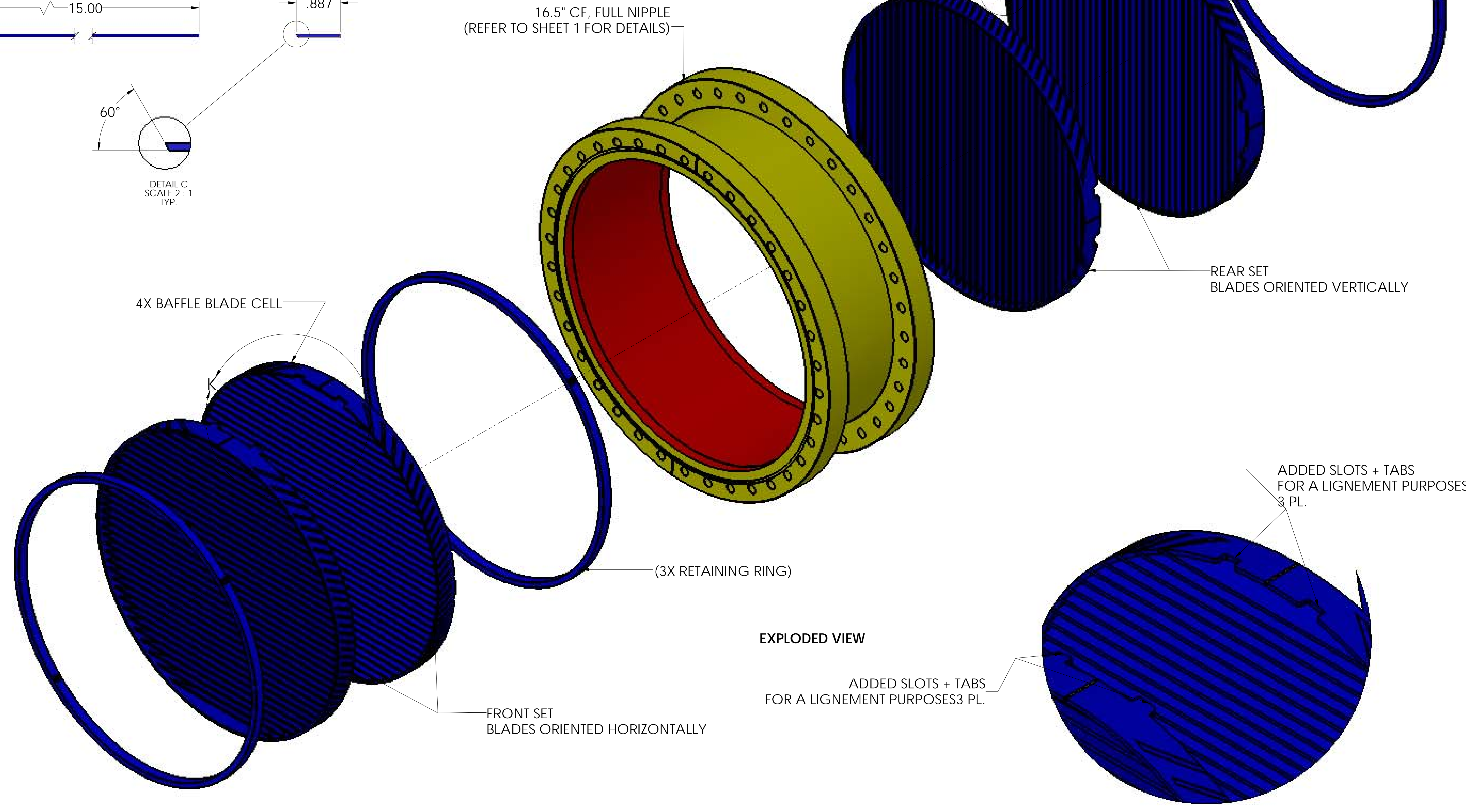

CHEVRON UV BAFFLE ASSEMBLY, BOLTED-TYPE 1

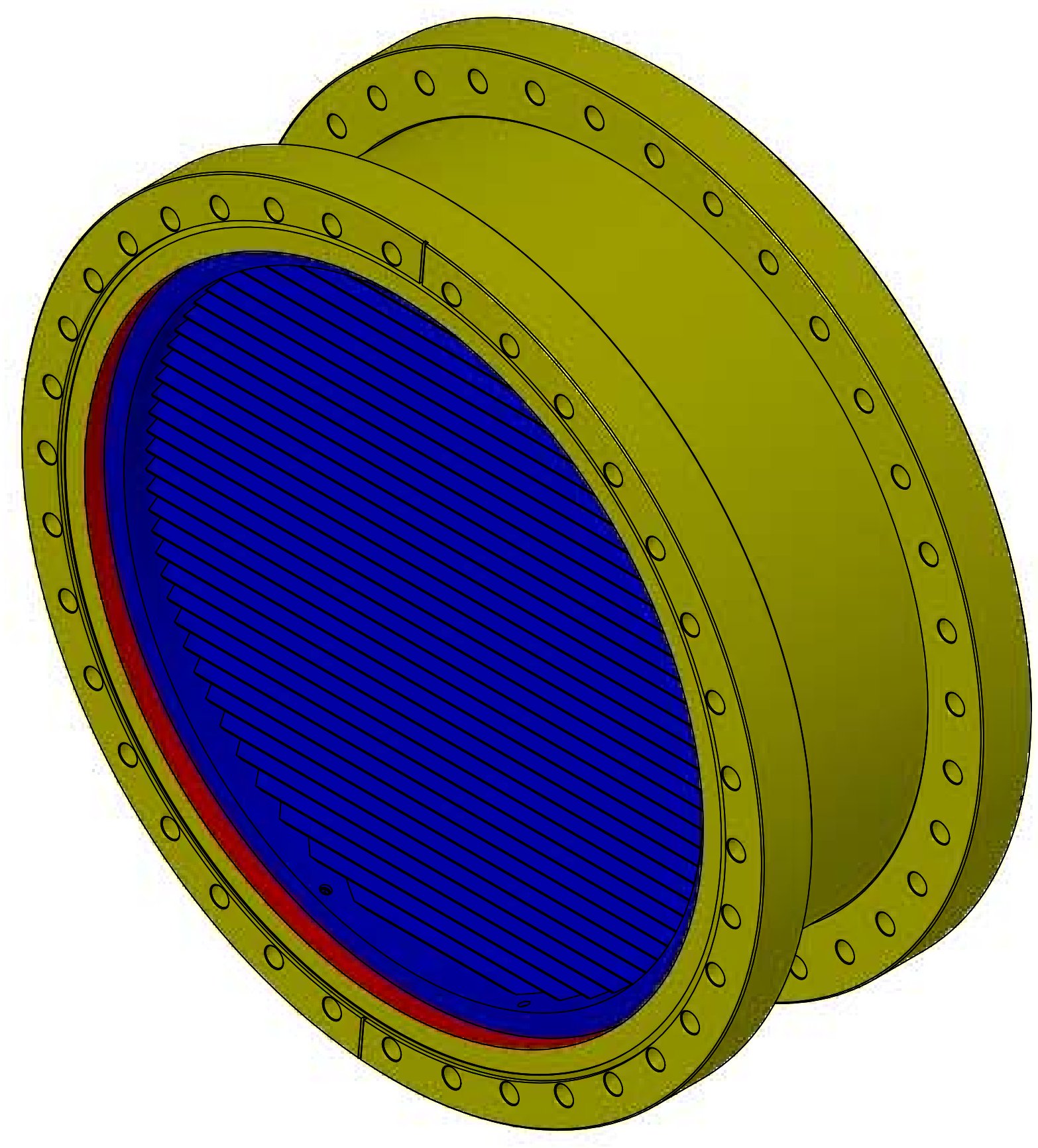

ISO VIEW, BOLTED-TYPE 1

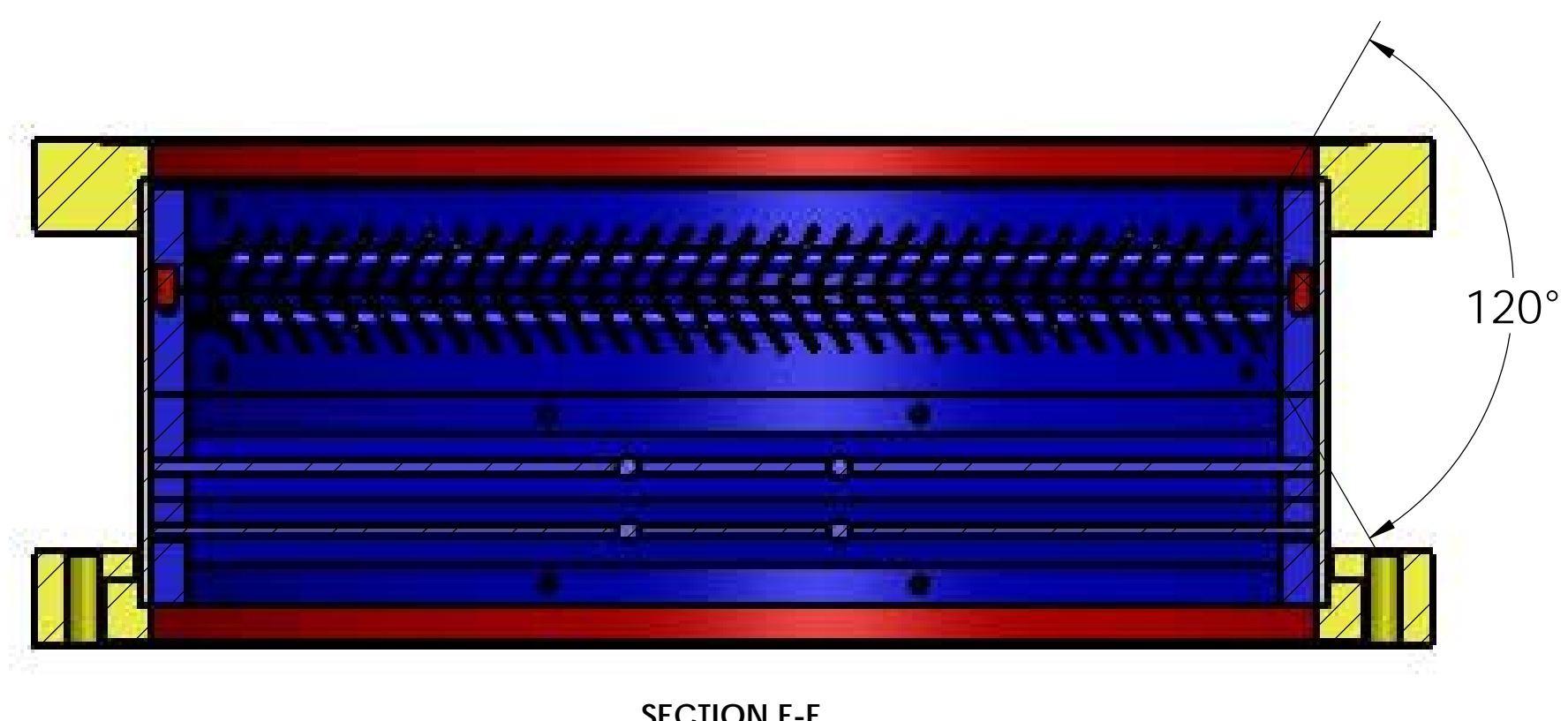

SECTION F-F

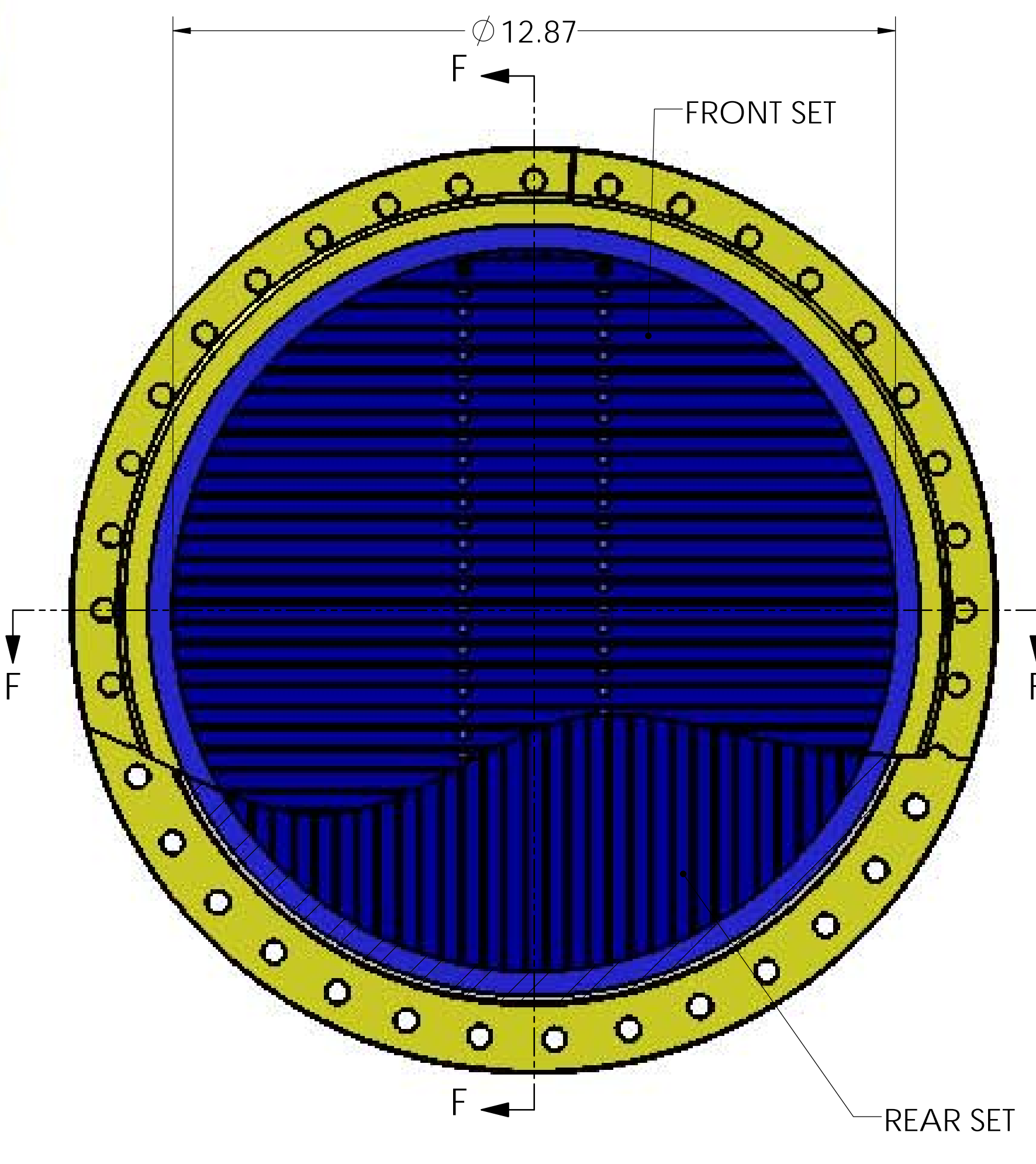

FRONT VIEW

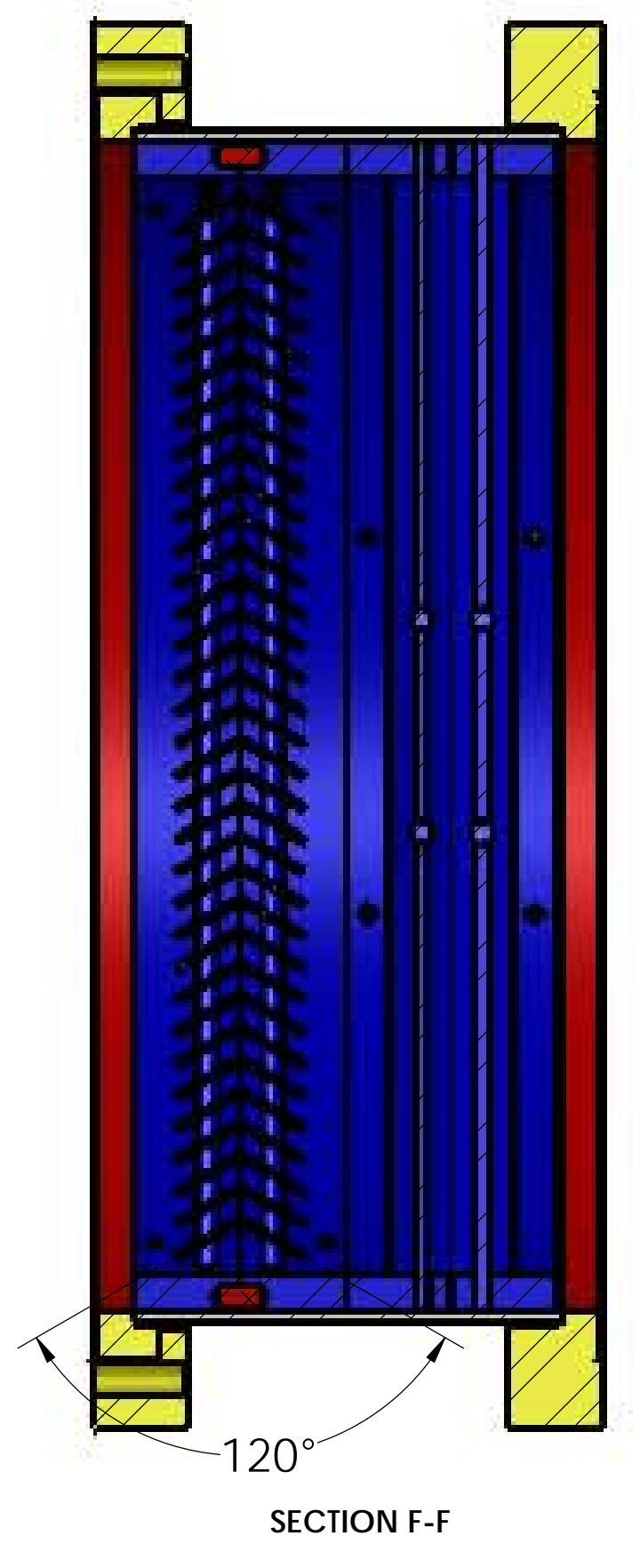

SECTION F-F

BLADE CELL CONSTRUCTION

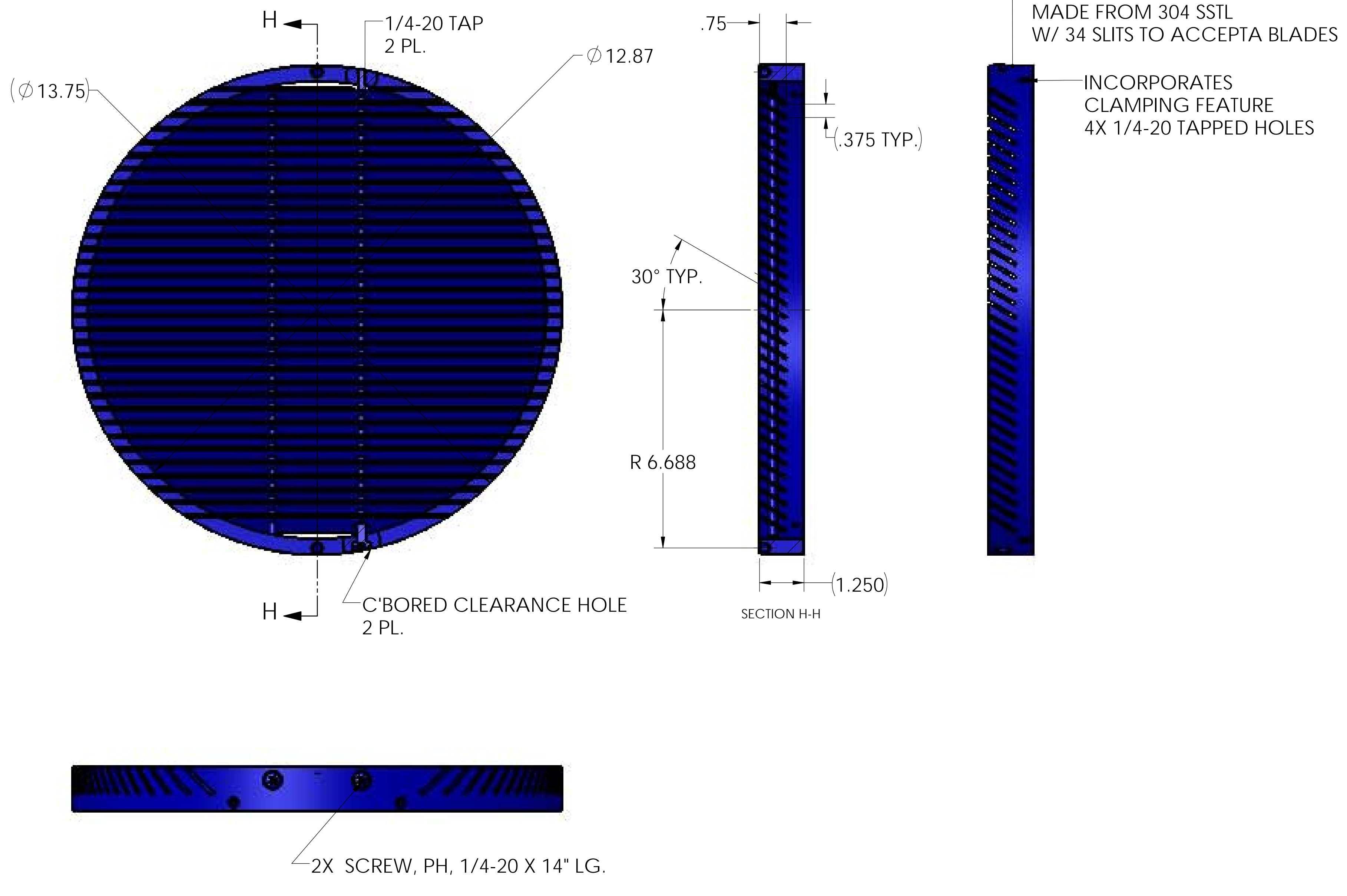

2X SCREW, PH, 1/4-20 X 14" LG.

BLADE DETAIL

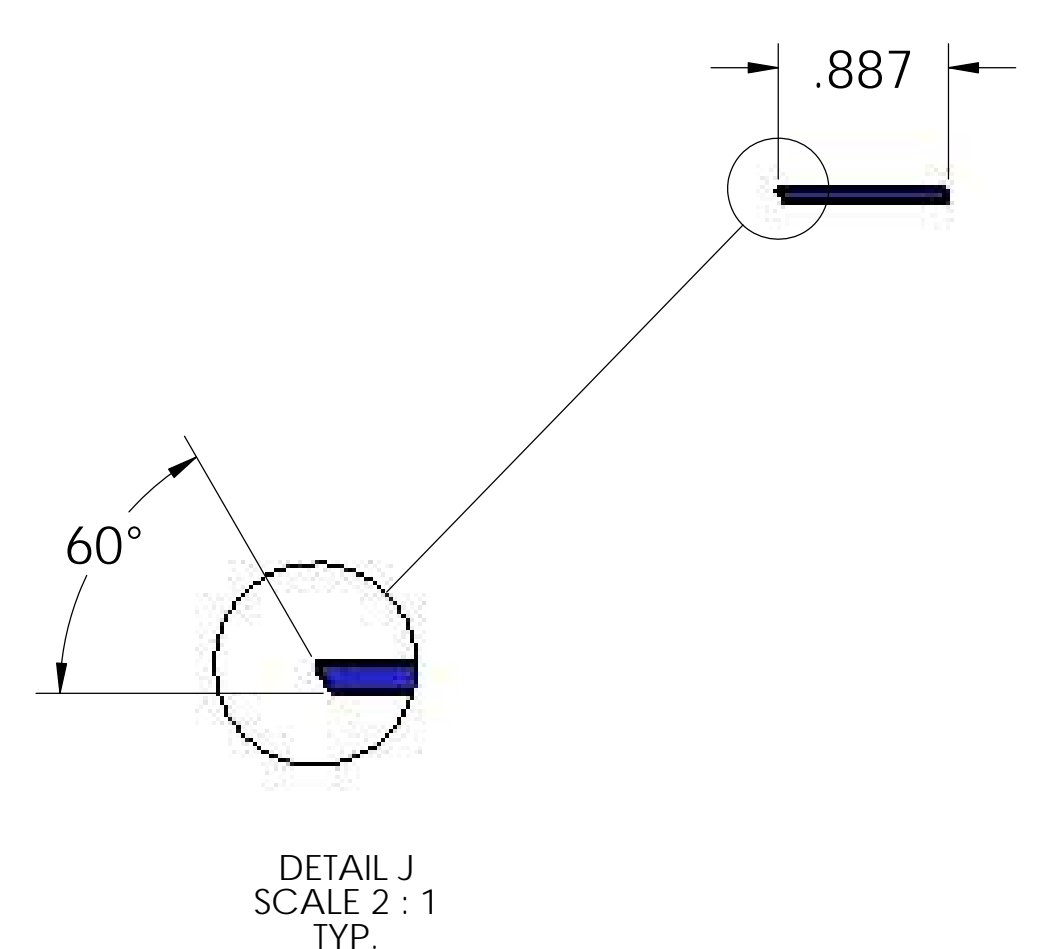
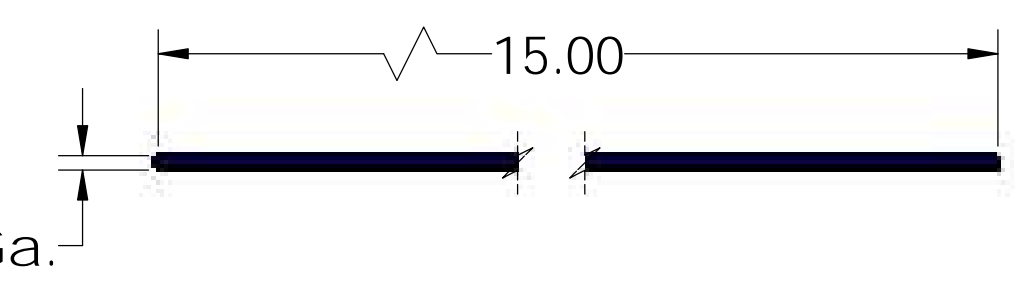

DETAIL J SCALE 2:1 TYP.

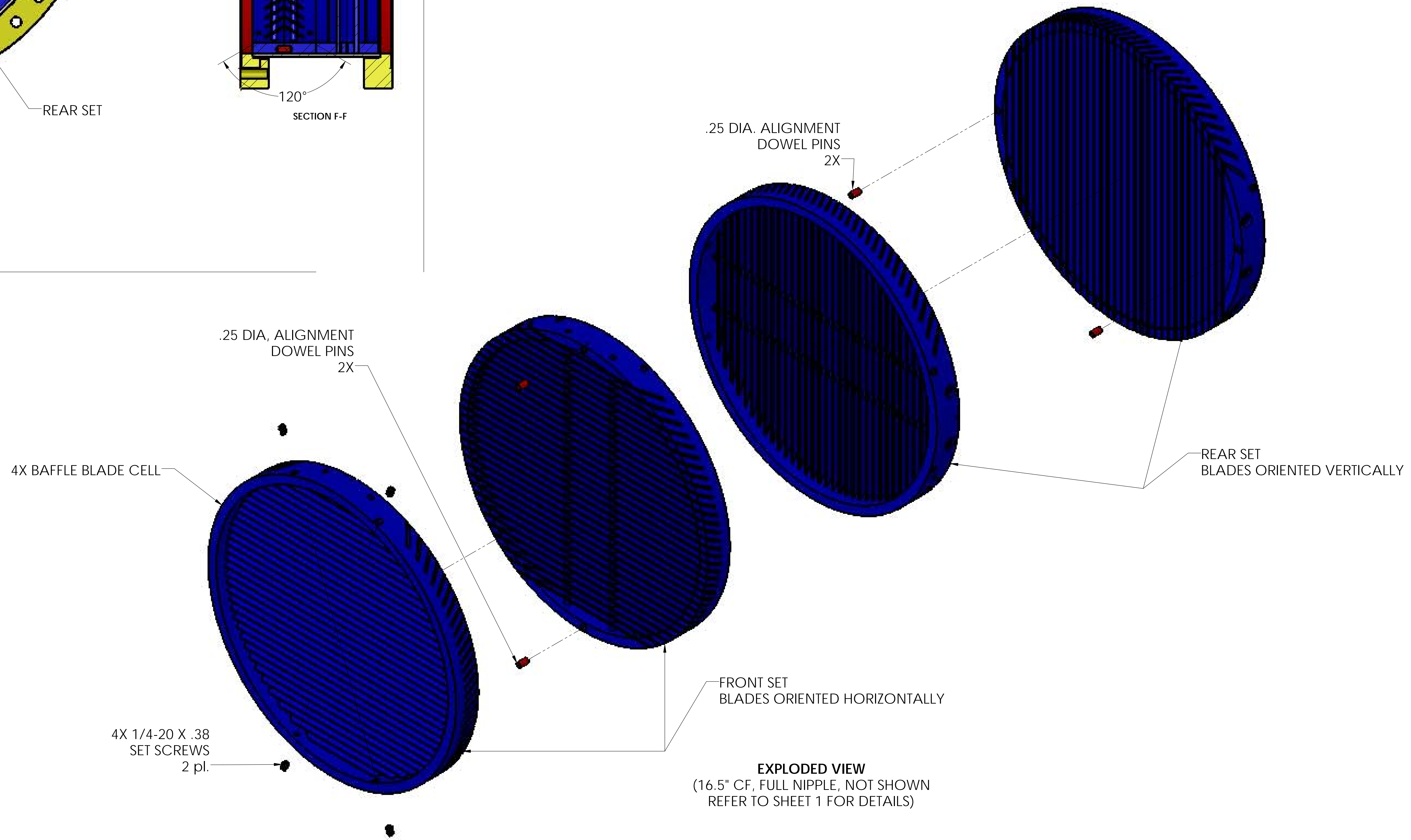

EXPLODED VIEW (16.5" CF, FULL NIPPLE, NOT SHOWN REFER TO SHEET 1 FOR DETAILS)

CHEVRON UV BAFFLE ASSEMBLY, BOLTED-TYPE 2

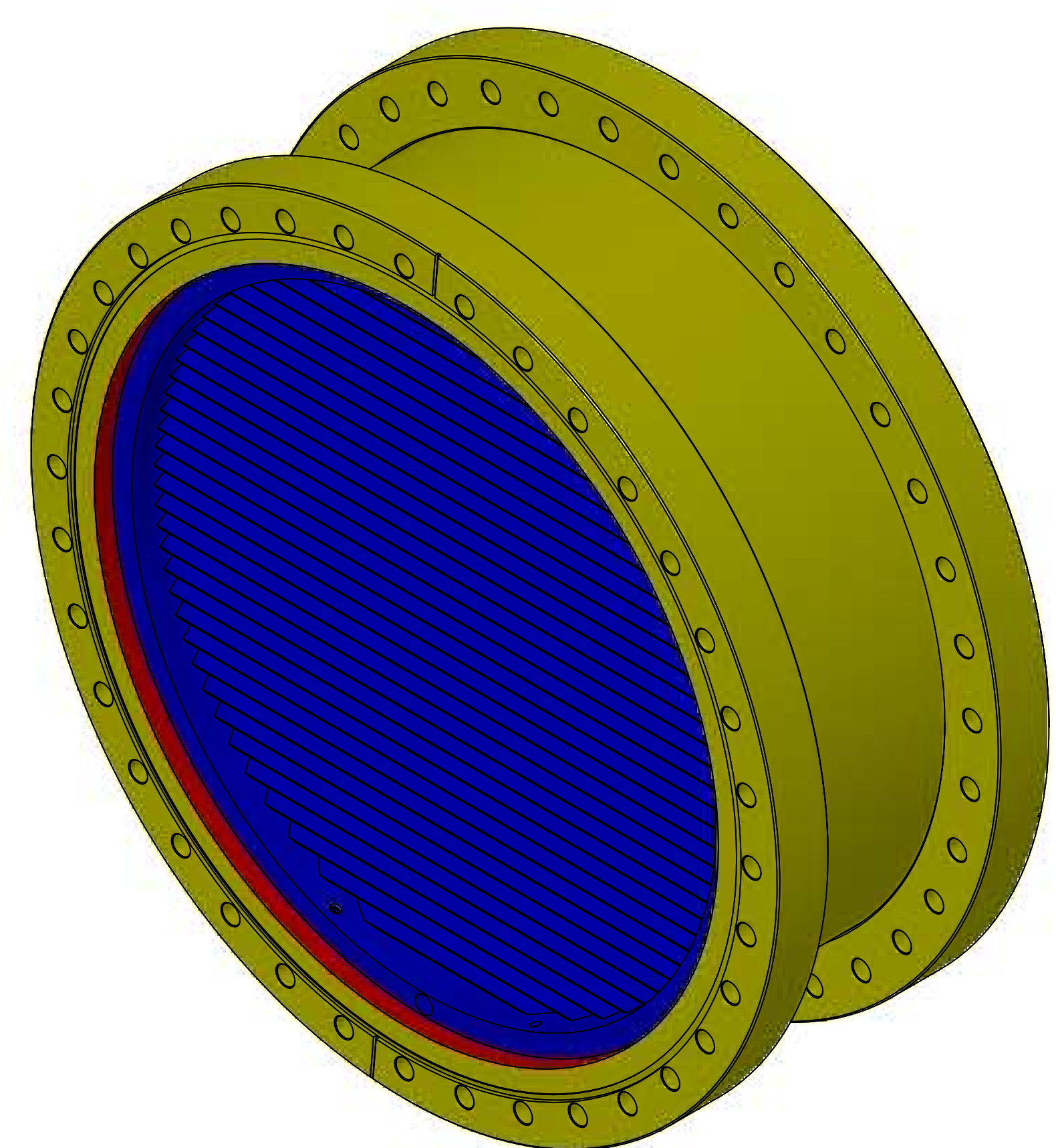

ISO VIEW, TYPE 2

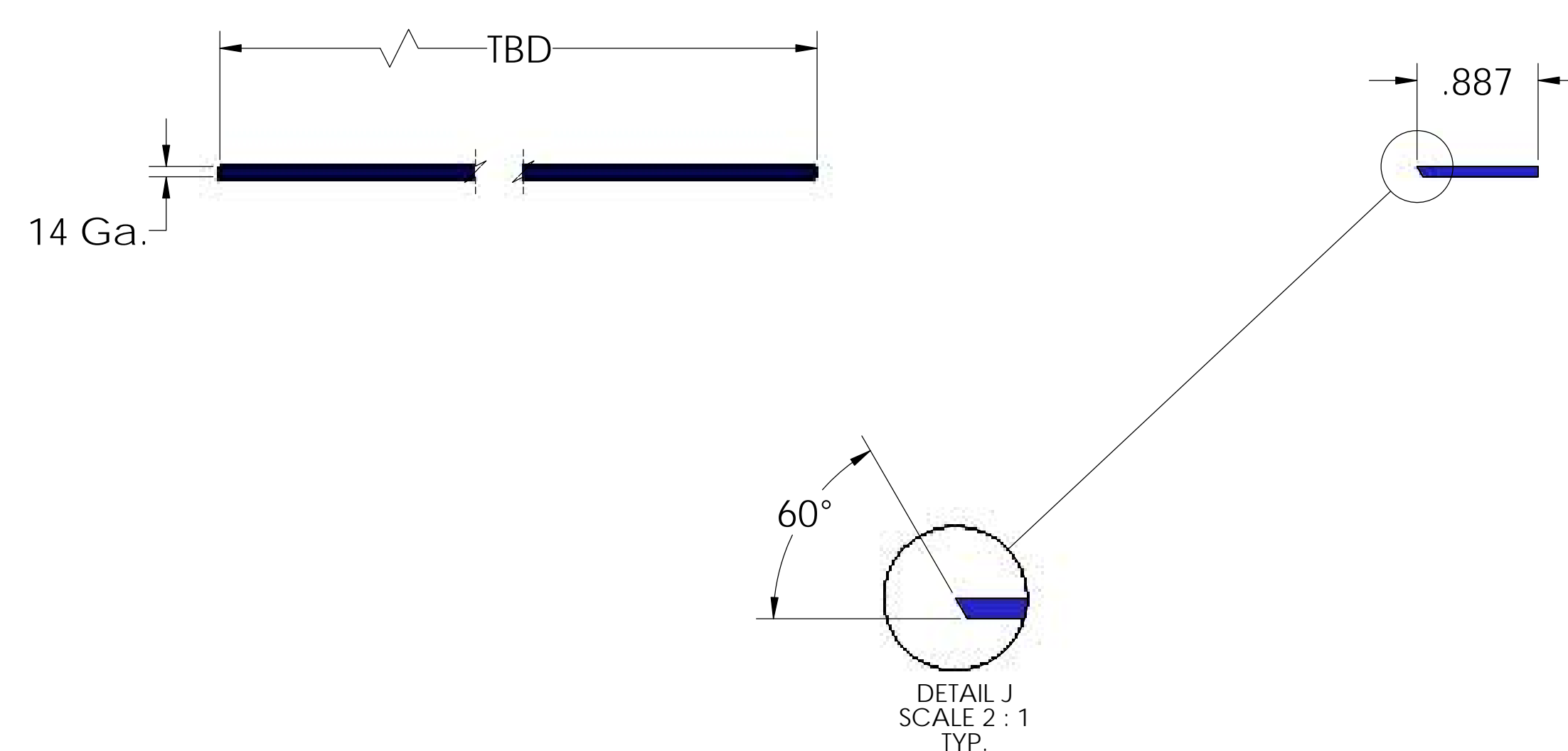

BLADE DETAIL

BLADE CELL CONSTRUCTION

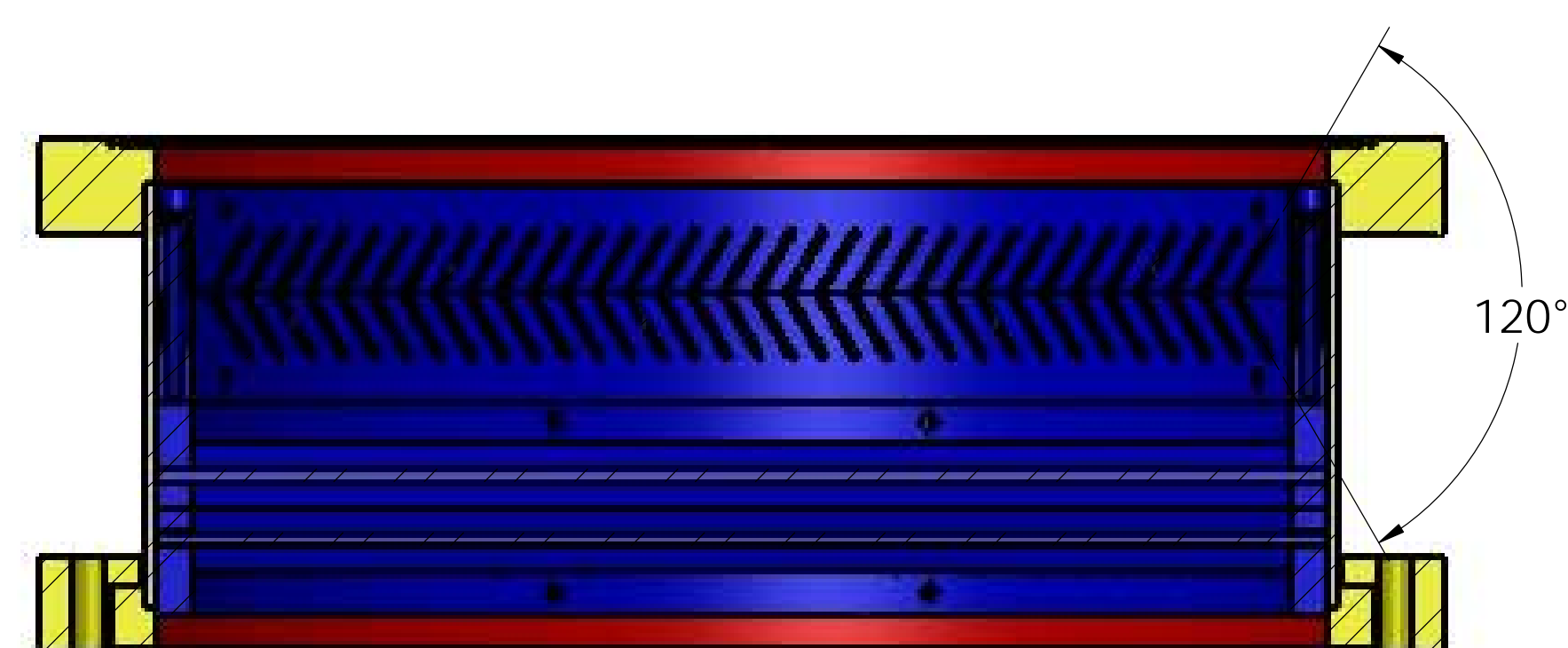
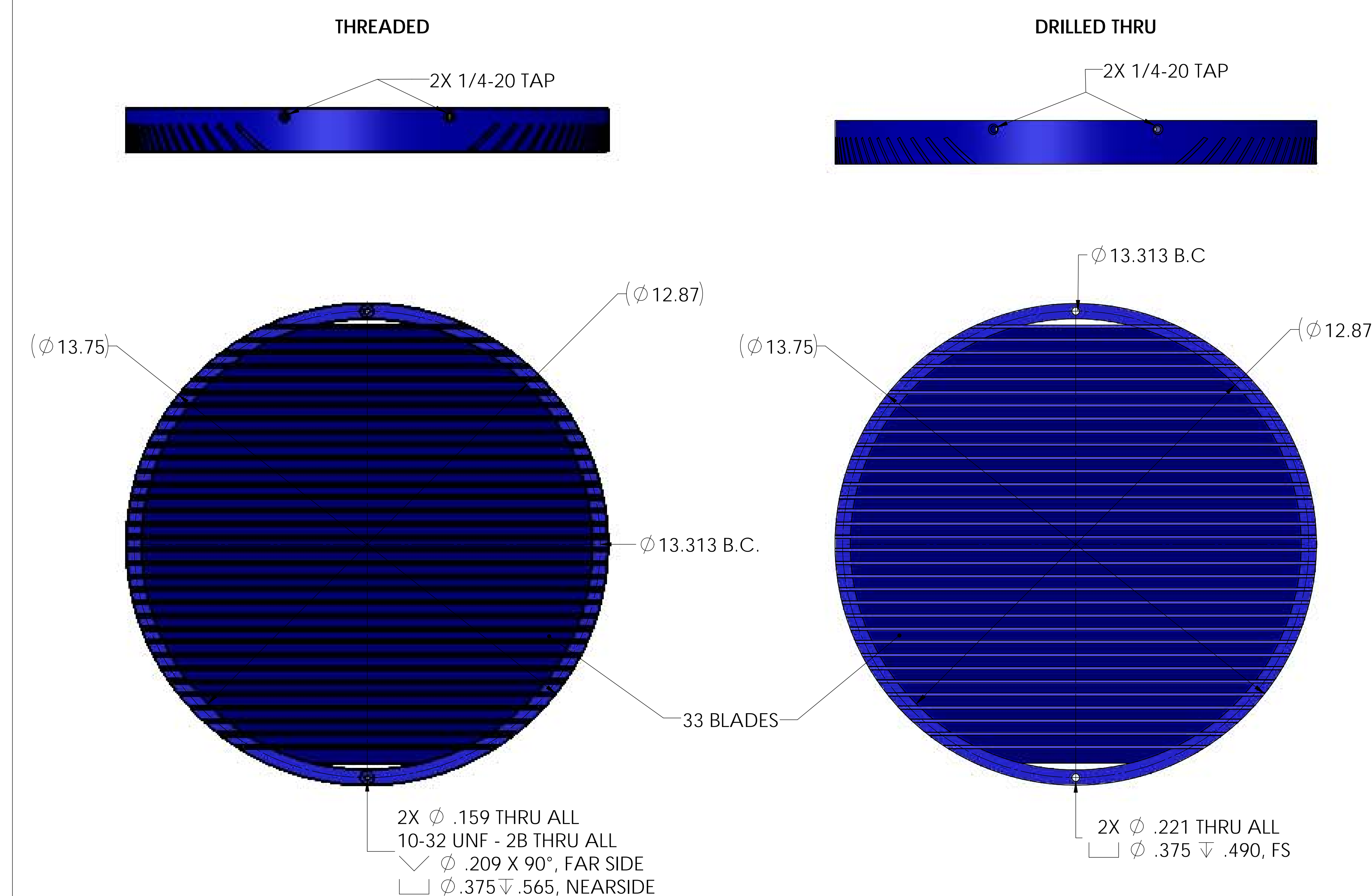

SECTION G-G

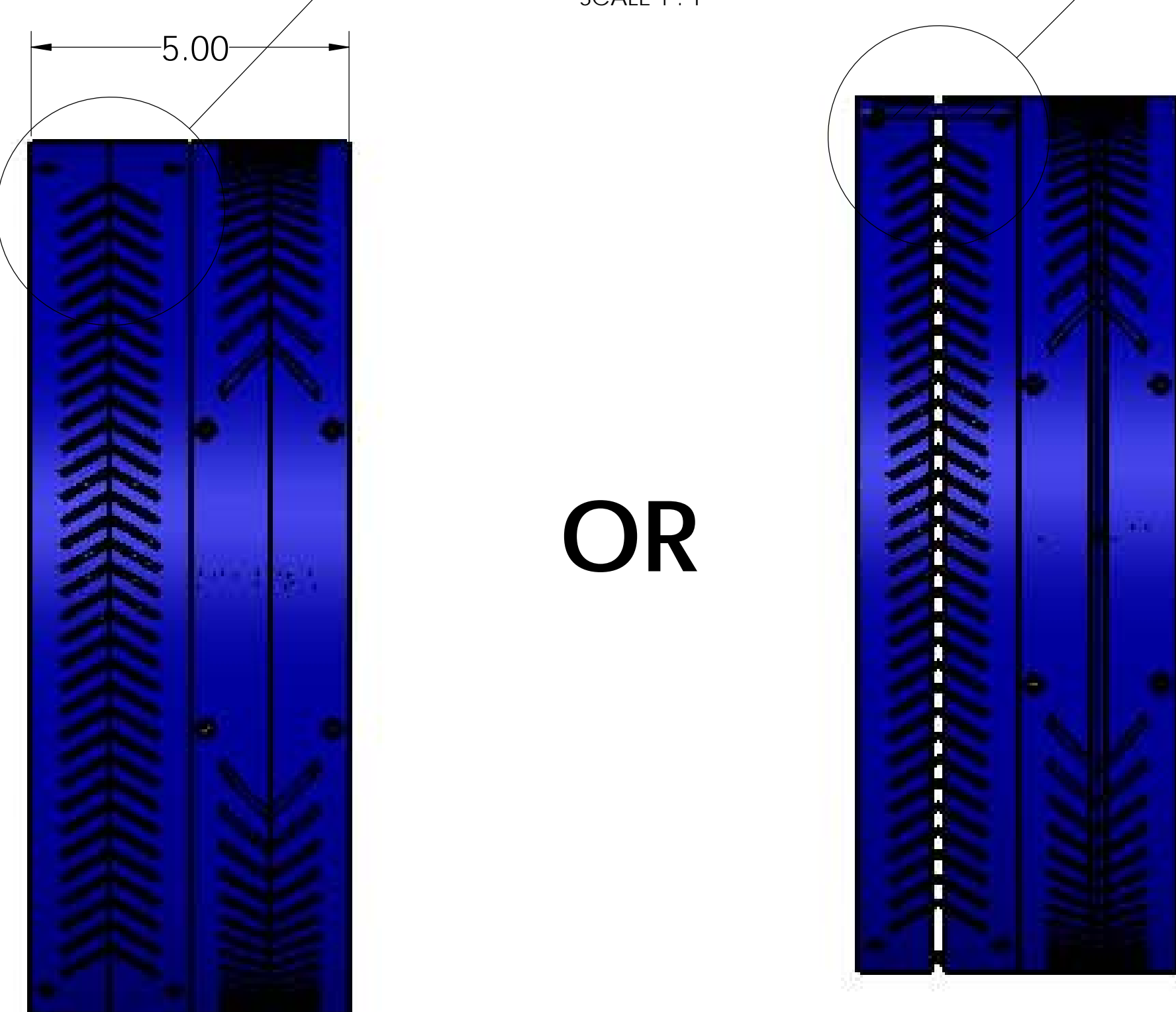
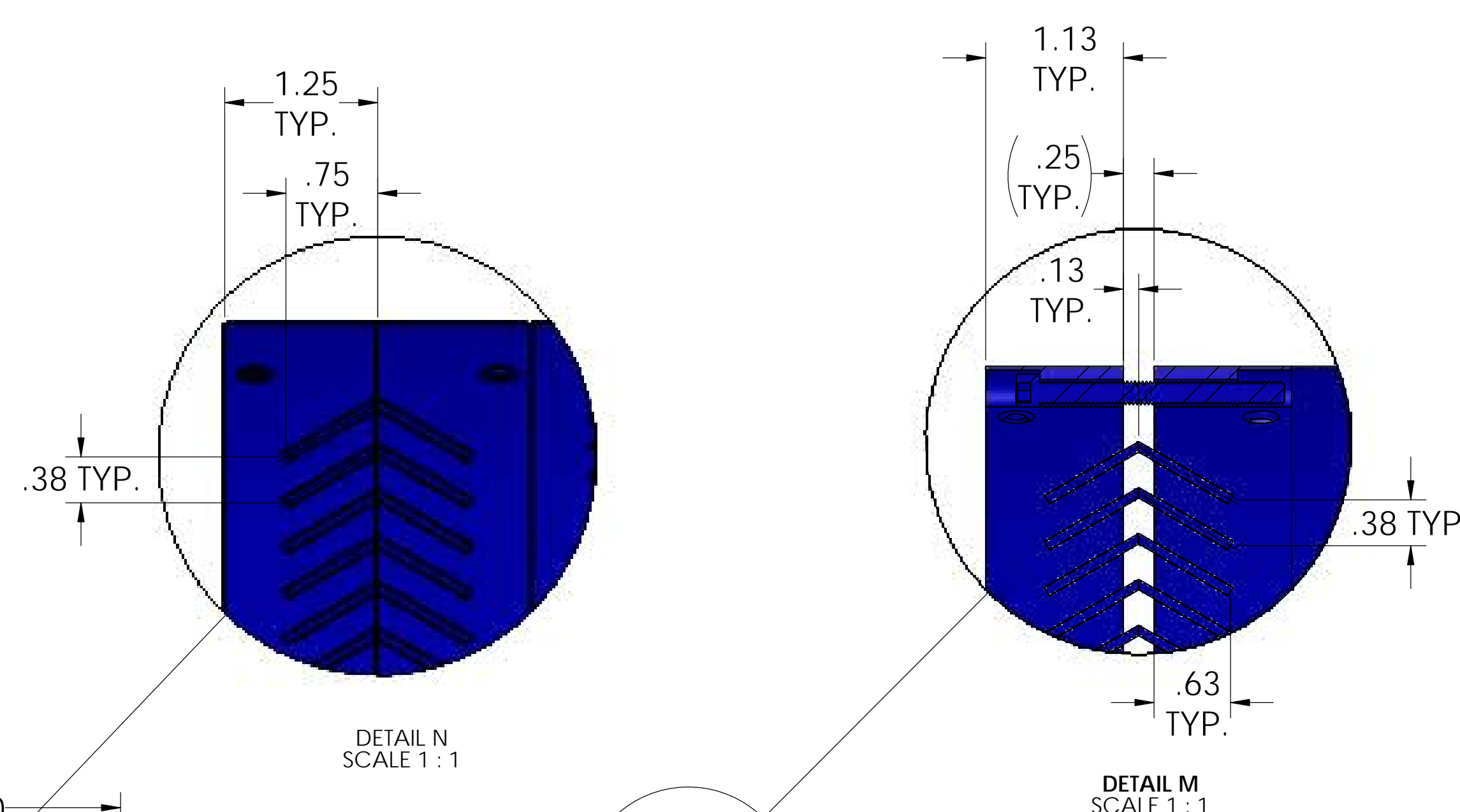

SIDE VIEW
 (16.5" CF, FULL NIPPLE, NOT SHOWN
 REFER TO SHEET 1 FOR DETAILS)

SIDE VIEW
 (16.5" CF, FULL NIPPLE, NOT SHOWN
 REFER TO SHEET 1 FOR DETAILS)

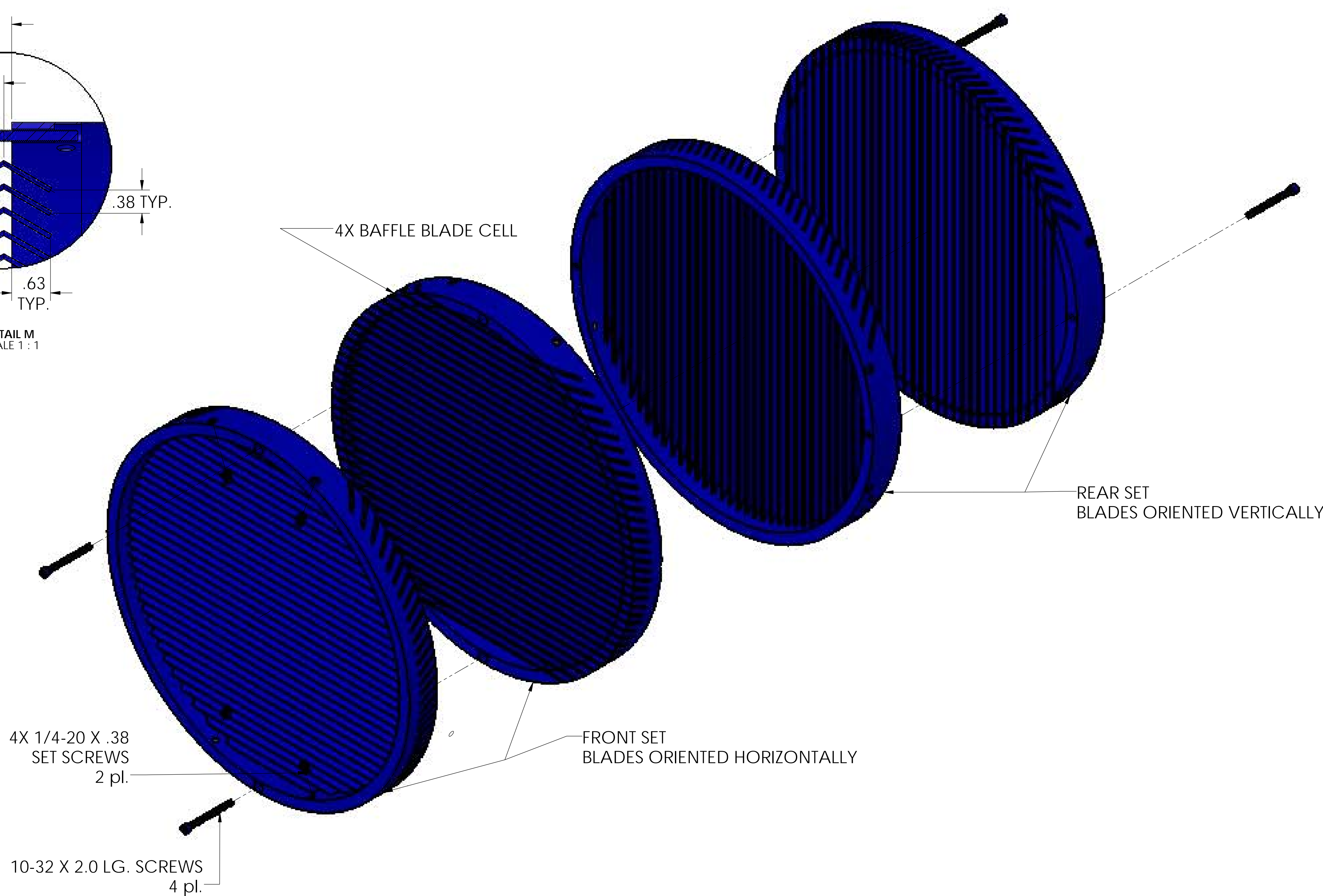

EXPLODED VIEW
 (16.5" CF, FULL NIPPLE, NOT SHOWN
 REFER TO SHEET 1 FOR DETAILS)

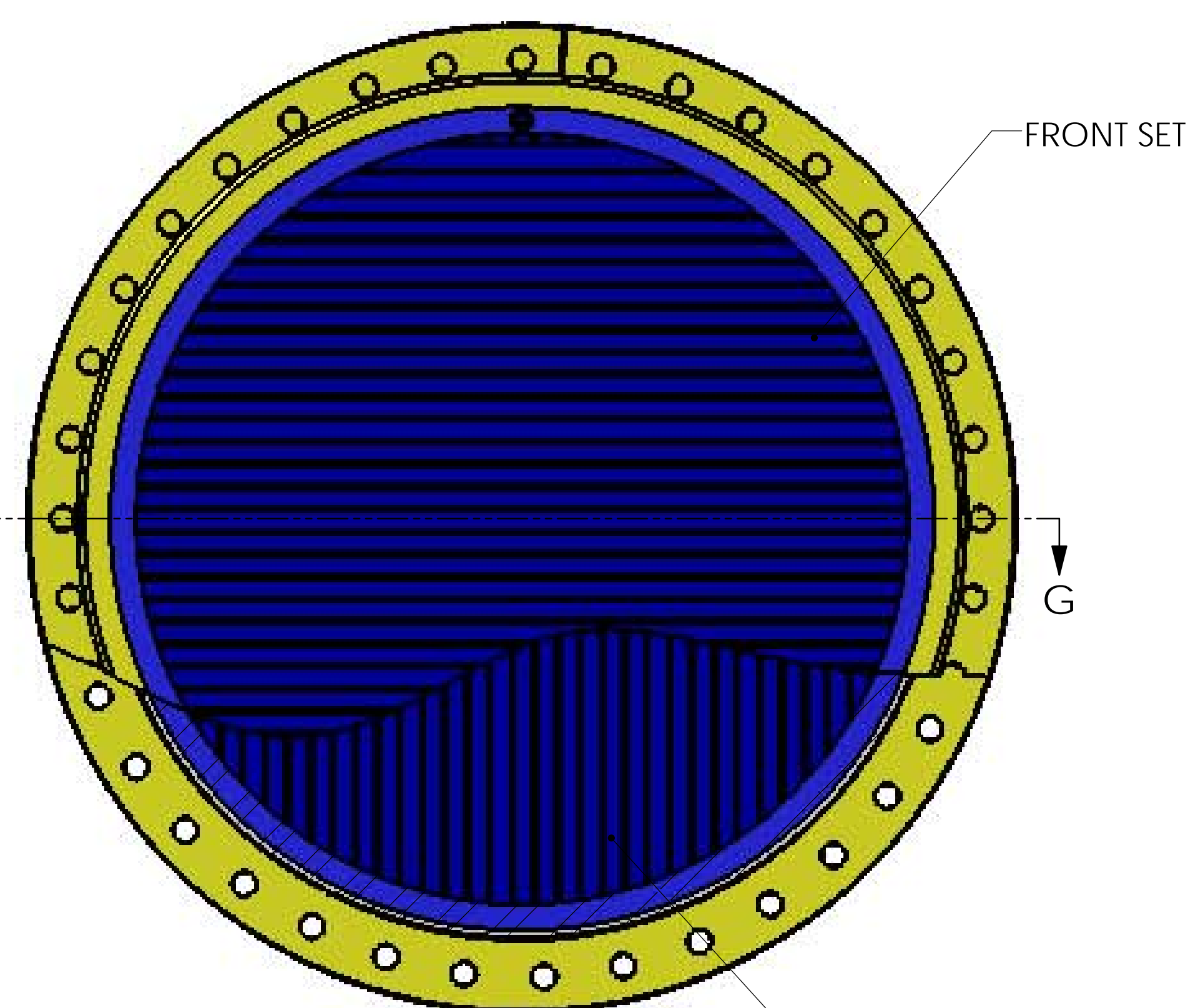

FRONT VIEW