

Title | *Fast Shutter Beckhoff Interface*
 Author | *R. Abbott, Caltech*
 Date | *24 October 2014*

Overview

The following note provides details on each of individual functions associated with the Beckhoff interface on the ISC Ultra-fast Optical Shutter as presented in D1400177. Refer to connection J1 on schematic D1300780 for details on the overall design. E1300689 has the channel listing for the applicable Beckhoff channel assignments for Corner Station Controls Chassis 6.

Connector Detail from D1300780

Figure 1, Beckhoff interface connector from shutter schematic

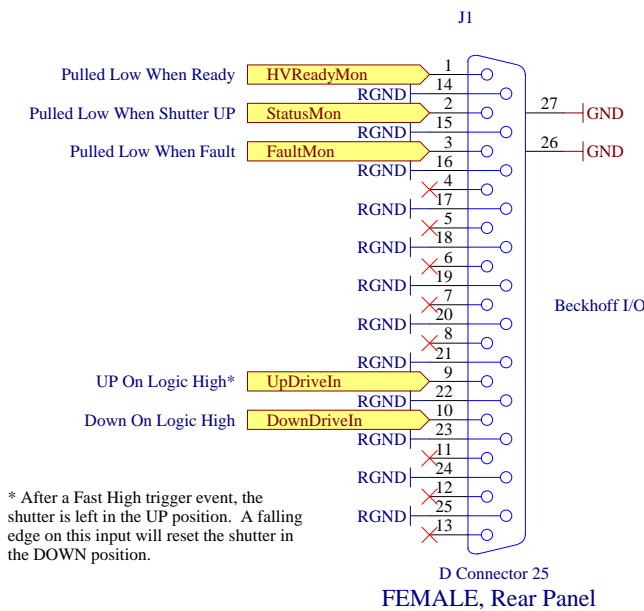

Individual Pin Details

Table 1 Pin Functions

| Pin Number | Pin Name | Type | Functional Details |
|------------|------------|-----------------------|---|
| 1 | HVReadyMon | Beckhoff Binary Input | This pin actively pulls low when the energy storage capacitors are charged above a firmware threshold. Firing the shutter before the capacitors are fully charged is prohibited in the shutter driver circuitry as damage may occur to the moveable coil in the shutter |
| 2 | StatusMon | Beckhoff Binary Input | This pin actively pulls low when the shutter is commanded to be in the UP or blocking state |

| | | | |
|----|-------------|------------------------|---|
| 3 | FaultMon | Beckhoff Binary Input | This pin actively pulls low if any fault condition exists: Input trigger cable disconnected, shutter controller unpowered, output cable to fast shutter disconnected, or any internal low voltage power supply more than 10% out of specification |
| 9 | UpDriveIn | Beckhoff Binary Output | On the rising edge of a logic high input (where high is in the range of 5 to 24VDC) the shutter moves to its blocking or UP position in a low current mode that can be sustained indefinitely. On the falling edge, the shutter returns back to the DOWN or not-blocking position by the restoring force of gravity alone. After a fast trigger event, the shutter will latch into a blocking (UP) state. A strobe of this input is necessary to reset the shutter to the not-blocking (DOWN) state |
| 10 | DownDriveIn | Beckhoff Binary Output | On the rising edge of a logic high input (where high is in the range of 5 to 24VDC) a 20mSec pulse is applied in the DOWN direction to reset the shutter in the event it ever gets stuck in the UP or blocking state. It is unlikely that this input will be used often as the shutter should restore by gravity alone. This is a last ditch option |

Interface Circuit Details

The Ultra-fast Shutter uses the following circuits for the Beckhoff interfaces:

Figure 2, Shutter status monitor output circuit to Beckhoff binary input. The right hand side of the schematic goes to the Beckhoff interface

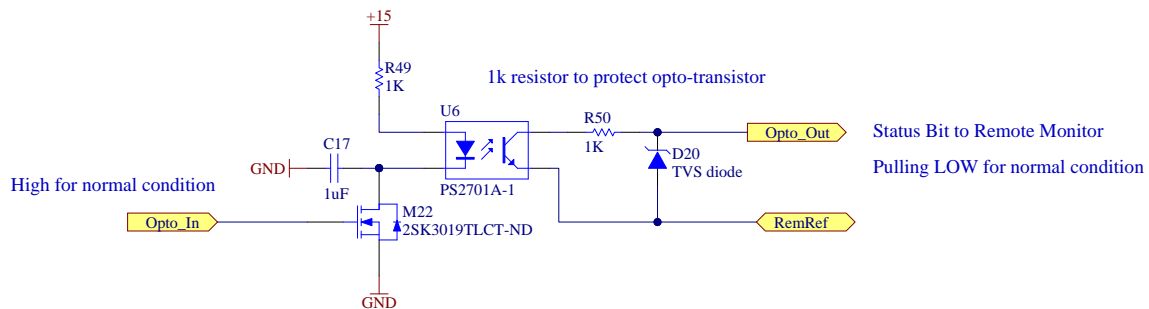
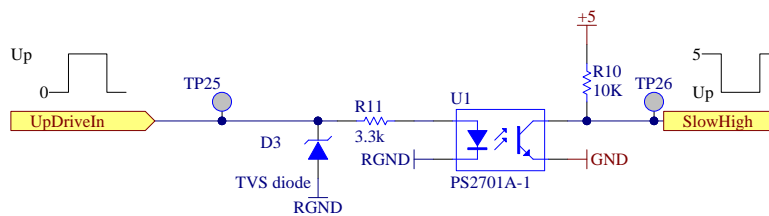

Figure 3, Shutter input circuitry receiving an input on the left hand side from the Beckhoff interface



Miscellaneous Operational Details

The architecture of the Ultra-fast Optical Shutter driver circuit D1300780 is such that various states are prohibited in order to protect the underlying circuitry. For example, if a command to fire the shutter UP were issued at the same time as a DOWN pulse, or low current UpDriveIn command, the high voltage pulse could be applied to low voltage elements of the circuit causing immediate destruction of the shutter driver.

Considerable thought went into the operational state machine logic of the shutter. A consequence of this is that after a fast pulse, the shutter holds in the UP position until a strobe of the UpDriveIn command input is applied. After the strobe, the shutter will fall by gravity back into its DOWN position and is once again available to receive fast triggers from the shutter controller input.