



LIGO Laboratory / LIGO Scientific Collaboration

LIGO- T1400652-v1

LIGO

11 Oct 2014

Technical Proposal to the Vacuum Review Board (VRB)
for
Decommissioning the LHO Mid-Station Cryopumps

Dennis Coyne

Distribution of this document:
LIGO Scientific Collaboration

This is an internal working note
of the LIGO Laboratory.

California Institute of Technology
LIGO Project

Massachusetts Institute of Technology
LIGO Project

LIGO Hanford Observatory

LIGO Livingston Observatory

<http://www.ligo.caltech.edu/>

1 Introduction

For the Advanced LIGO Project, the mid-station BSC chambers at LHO were moved to the end-stations. Since there are no longer any chambers and interferometer elements in the LHO mid-stations, it is reasonable to consider decommissioning the mid-station cryopumps. There are 2 pumps in each mid-station at LHO. This would reduce the cost of LN2 consumption (estimated at ~\$110K/yr). However there are a number of risks which must be addressed and a work plan is needed.

The purpose of this memo is to give the VRB's resolution/direction for each of the issues/concerns and

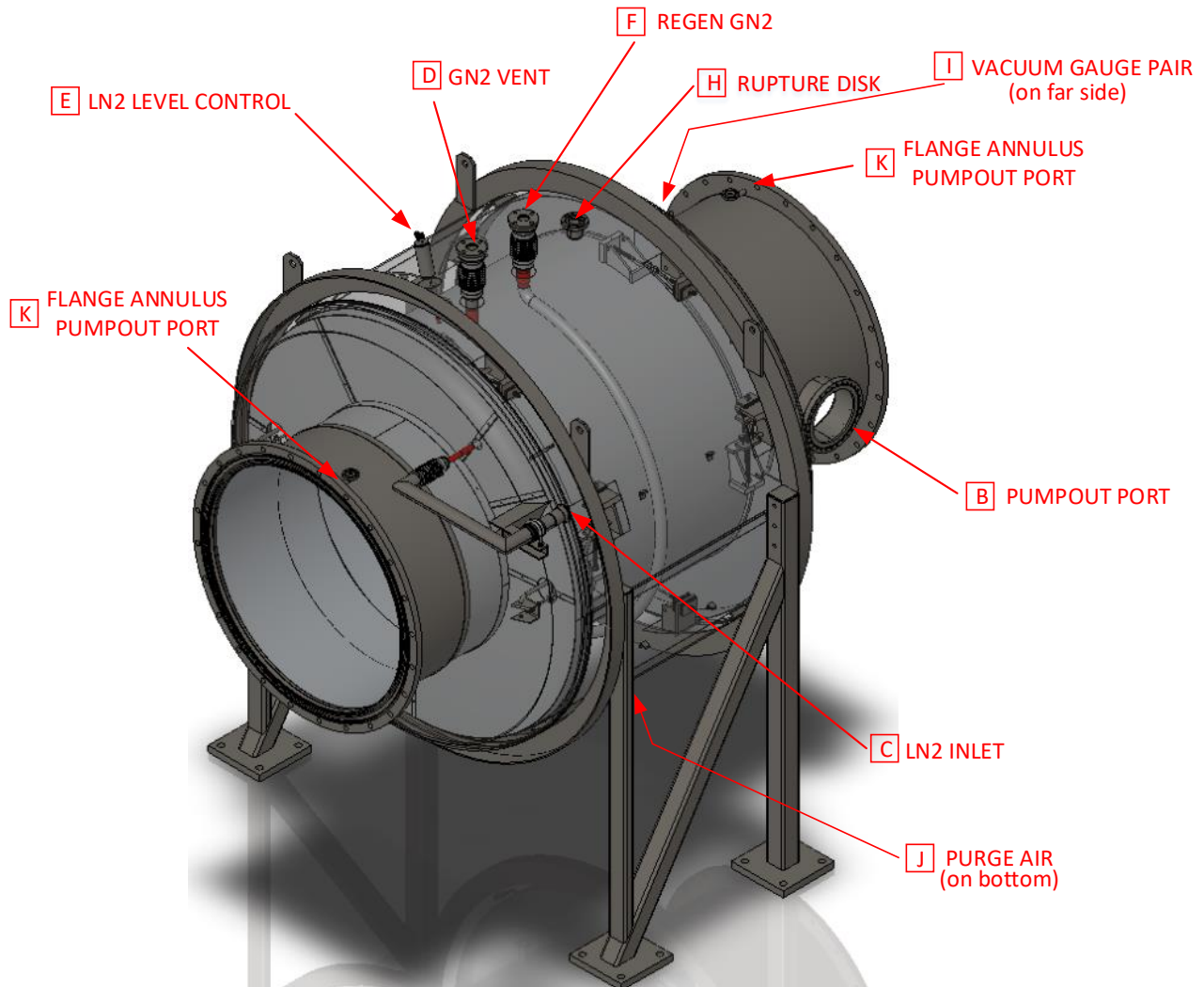

Figure 1: 80K Pump (Short, Right Version, PSI V049-4-005, Rev. 3 (as built)), shown with transparent outer shell.

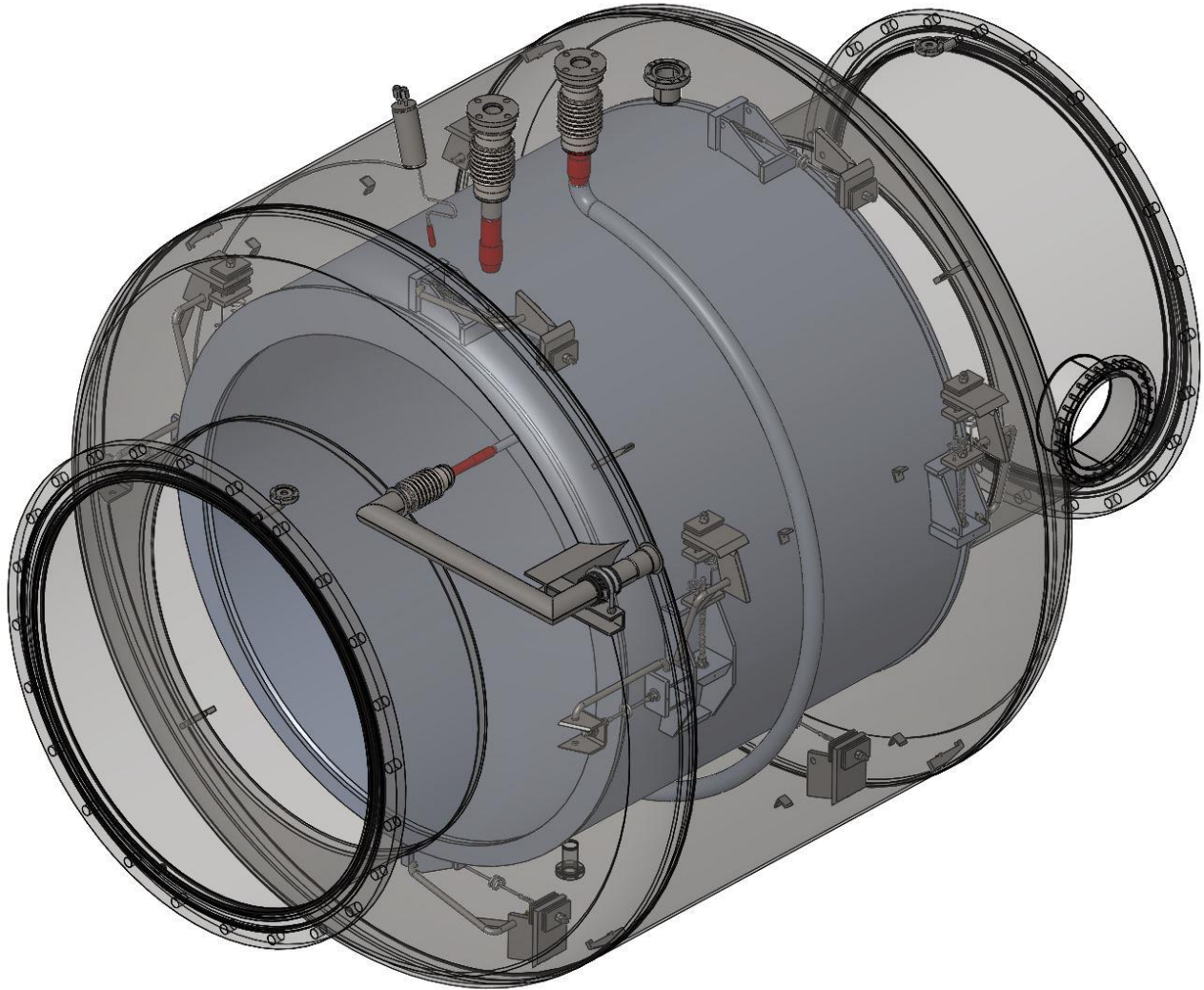

Figure 2: 80K Pump shown with radiation shields and leg assembly removed and outer vacuum shell transparent.

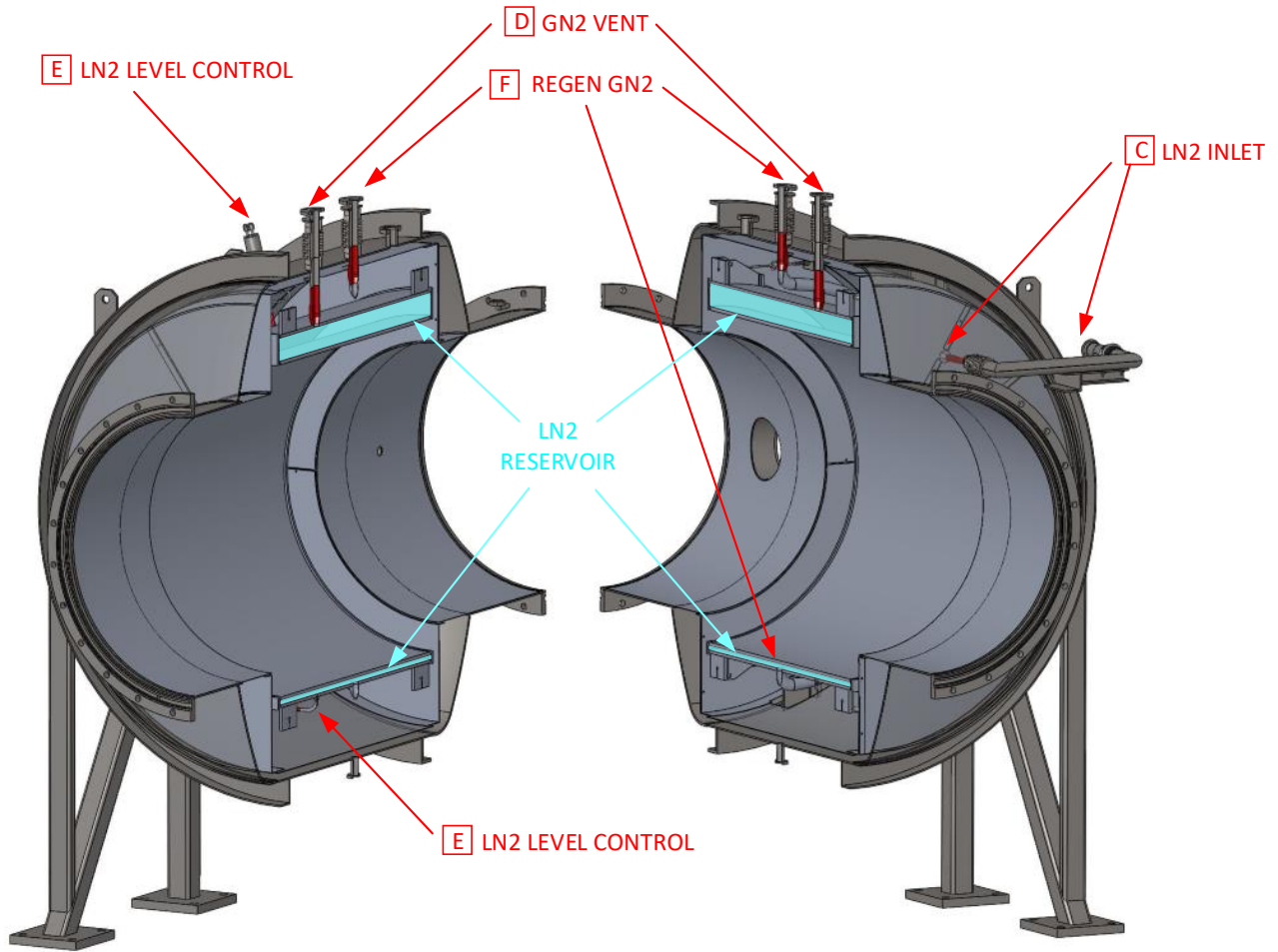

Figure 3: Cross-Sectional View of the LN2 Reservoir and Piping

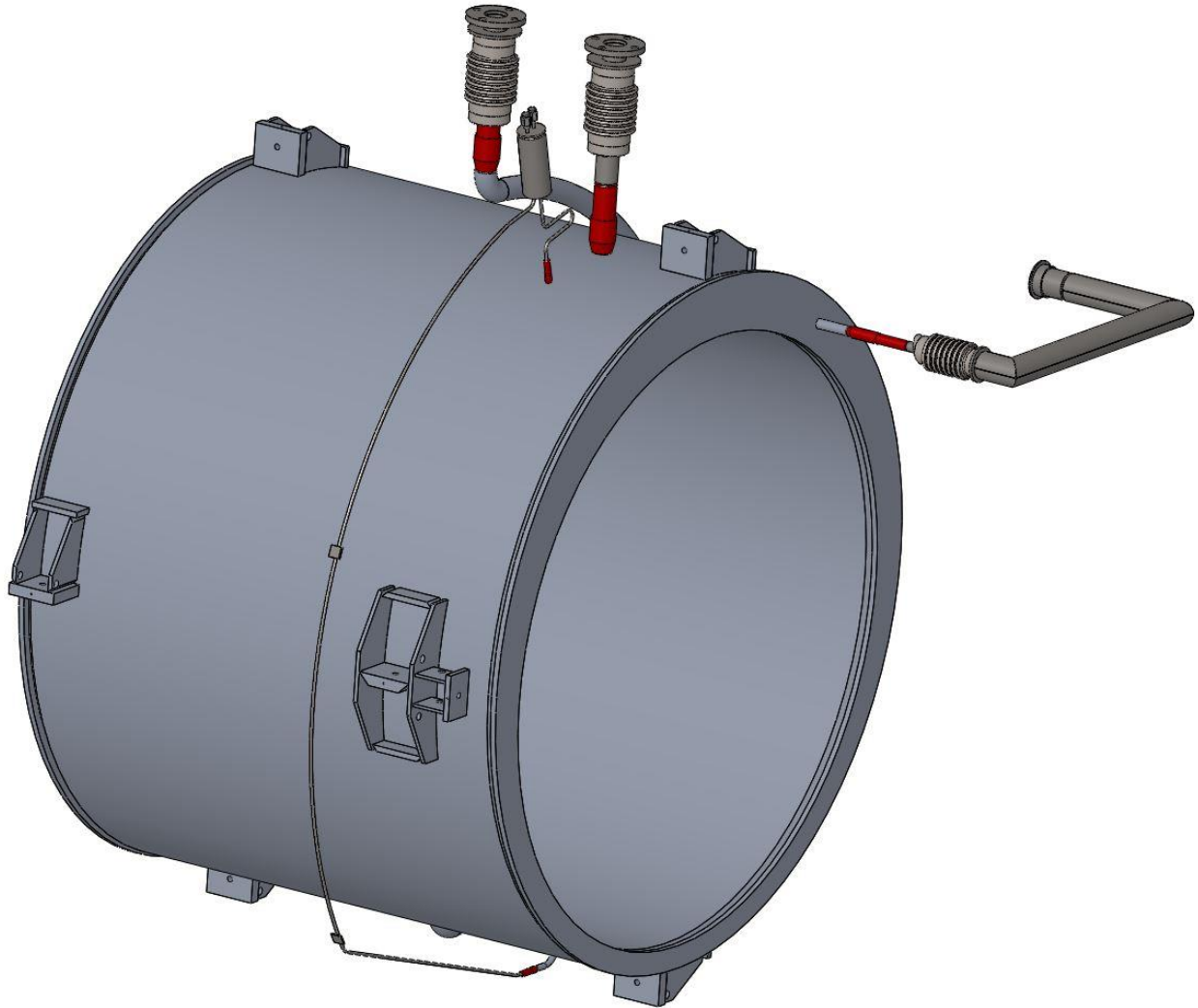

Figure 4: LN2 Reservoir and Piping (without the vacuum shell and mechanical ‘suspension’ hardware)

The welding details for the five ports into the LN2 reservoir are shown in REF???

2 Potential Technical Issues/Risks

Each of these issues is discussed below, with the VRB’s resolution/decision.

2.1 Adequate pressure without mid-station pumps

Unlike the LLO mid-stations, LHO has a number of large o-rings (in pumped annulus arrangements). Is the diffusion rate through these o-rings low enough to permit no pumping at the mid-station?

<perhaps Rai can calculate this for us.>

2.2 Bi-braze joint failure risk

Heating the pumps (e.g. via a hot gas system) may lead to failure of the bi-braze fittings or other vacuum joints. If such a failure occurred the potential repair time is excessive (> 6 months). How do we mitigate the risk to an acceptable level?

PSI had some difficulty with the bi-braze joints and elected to proof test (cryo cycle) all units before accepting and welding them into our 80k pumps. Many of the units failed this cryo cycle testing. We do not know if PSI used units that survived the cycle testing but were built with the same design & manufacturing process, or if they switched to another design/process in which all units survived the cryo cycle testing; **speack with Rich Bagley.**) The attached drawing shows how they are configured inside the pump.

The India IPR team is very nervous about Al-SS transitions for LN2 service (this comes up often in fusion machines). Manoj Kumar (LIGO India project) would much rather design an all-SS solution.

We have regenerated the LLO cryopumps without incident ca. 2003 or 2004 (maybe). LN2 consumption declined measurably afterward, presumably because the low emissivity of the cold surface was restored. Although initial testing can exhibit good tensile strength results, in service the CTE stresses between the two dissimilar materials can cause braze failure (often due to brittle intermetallic compounds)^{1,2}.

Although LLO has successfully cycled/regenerated their cryopump a couple (few?) times, this is not sufficient testing to insure that future failures will not occur. Given the significant downtime that this risk entails it is the VRB's strong recommendation that measures be taken to accommodate a failure of the b-brazed joint in case it should occur.

The bi-braze joints are shown in [D970362](#)-x0, sheet 2 (PSI drawing V049-4-090, Rev. 2, sheet 2, "80K Pump Reservoir – short-right"). This reservoir is a subassembly of the overall 80K Cryopump ([D961096](#)-x0, PSI drawing V049-4-005, "80K Pump General Arrangement – short-right").

The bi-braze specification is PSI document WI-015-004, called out in the drawing (but we don't have a copy?). Neither the PSI plan for the 80K Cryopump Fabrication (V049-2-082, Rev. 0) nor the PSI specification for the 80K Cryopump Fabrication (V049-2-096, Rev. 1), nor the PSI Welding Specification (??) mention the bi-braze.

The VRB recommends that a means of isolating the vacuum containment (envelope) in the event that a bi-braze joint fails (leaks). While it is not possible to prevent communication from the cryo reservoir to the vacuum, it should be possible to seal the LN2 inlet, LN2 level control port, the regen GN2 port, and the GN2 vent port, and pull a vacuum on the interior of the reservoir. **<conceptually how can this be accomplished?>**

The VRB recommends that a design to accomplish the isolation be pursued and implemented prior to warming up the LHO mid-station cryopumps.

¹ Roulin, M. et. al., "Strength and Structure of Furnace-Brazed Joints between Aluminum and Stainless Steel", Welding Research Supplement, May 1999

² Martin, D.C., Method of Brazing Aluminum to Stainless Steel for High-Stress-Fatigue Applications", NASA SP-5040, 1968.

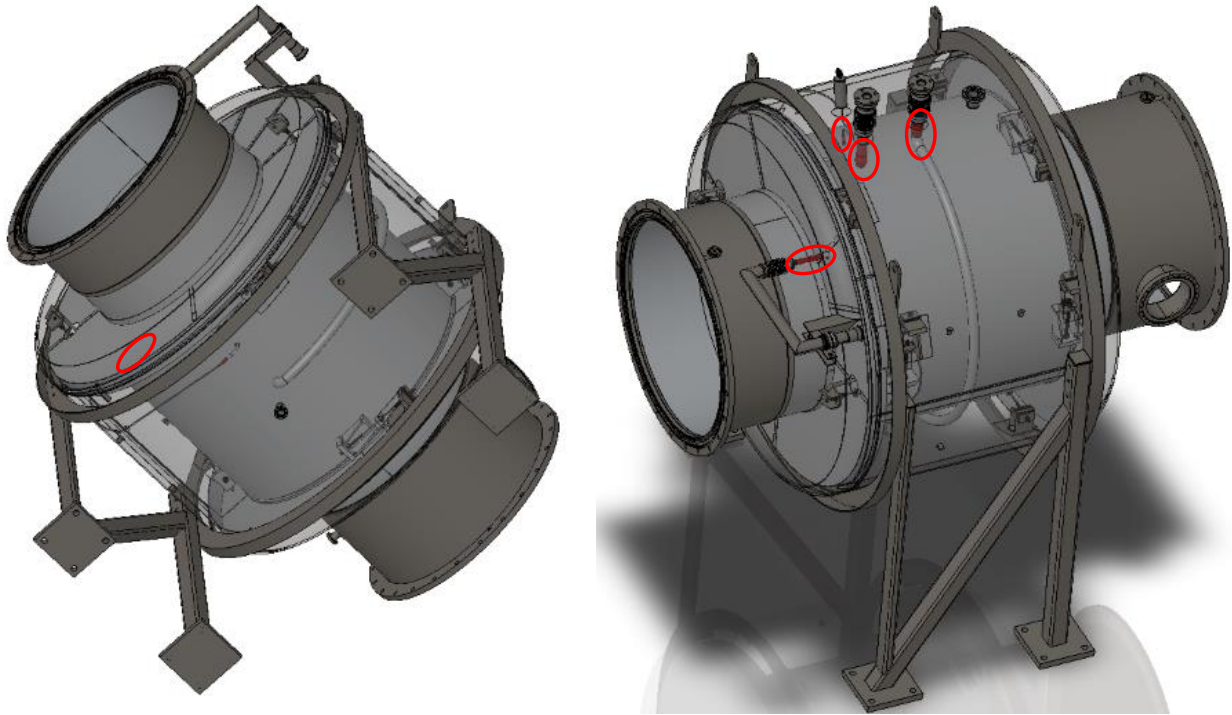

Figure 5: Bi-Braze Joints (5 bi-braze joints indicated by red ellipses)

2.3 Extent of the bake

Do we need to bake the 80K LN2 reservoir, just the 80k pumps vacuum jacket or the entire mid station?

Since the new vacuum spools installed by aLIGO are clean and have been baked prior to installation (**is this true?**), only the 80K pump needs to be baked (regenerated).

A normal regeneration process/cycle should be sufficient. However if a bi-braze joint does fail (**how will we know?**) then the condensed contaminants that may have accumulated on the interior of the reservoir may be able to leak into the main vacuum, even if we pull a vacuum on the interior of the reservoir.

2.4 Gate valve cycles and bake stress

When the mid-station cryopumps are warmed up and baked out to remove condensed contaminants that have accumulated, the 4 gate valves in each mid-station will be closed. Once the system is back to low pressure, the inner gate valves will be opened again, and an RGA measurement made of the mid-station vacuum volume (including the now warm cryopumps). If the RGA shows a clean system, then the outer gate valves will be opened to the beam tubes. This subjects each of 8 gate valve to a minimum of one cycle each.

The bake out of the 80K pump will subject the adjacent gate valves to some thermally induced stresses. Although these gate valves were designed to be baked, it was for a different bake condition. The design condition was for the beam tube to be at 150C and the gate valve insulated. For the case under consideration here, the cryopump will be heated and the beam tube will be cold. We should insulate the gate valve to minimize gradients.

There is a small, but finite risk that one of the 8 gate valves will not re-open, or will cause a leak (such as the one currently being repaired at LLO). These risks, and the consequent impact on interferometer commissioning, must be considered against the reduction in cryogen costs.

Perhaps an adjacent section of the BT should also be heated?

<what more to say? What can we do in the way of analysis?>

3 Proposed solution

We assume that one (or more) of the bi-braze joints will fail, and prepare for this eventuality by connecting evacuating the LN2 reservoir volume. Two approaches could be employed:

- 1) Evacuate the LN2 reservoir volume with a separate pumping system: This approach has the disadvantage of requiring maintenance of a separate vacuum system. If the LN2 reservoir is anticipated to be contaminated by the condensed contaminants of the LN2 which has been pumped into the reservoir over many years of operation, then this approach isolates these contaminants from the main vacuum, except for that fraction which might diffuse through the (hypothesized) cracks in the bi-braze joint(s).
- 2) Connect the LN2 reservoir volume to the main vacuum system. This approach directly communicates the LN2 reservoir volume with the main vacuum volume. If contamination within the reservoir is a concern, then this would likely require an elevated temperature bake out of the 80K pump assembly.

For either approach the five ports into the LN2 reservoir must be sealed (by plugging or connecting to each other and/or a vacuum source). Two of the LN2 reservoir ports are FPT (female pipe thread) fittings. Pipe thread joints are not appropriate for ultra-high vacuum systems and their use should be avoided in high-vacuum systems^{3,4}. A potential solution to the leak reliability of the NPT fitting is to silver solder the threaded joint (using capillary action to draw the solder into the threaded interface). However this approach will not reduce the potentially significant volume of trapped gas volume in the threads. A better approach is to silver solder a plug to the face of the FPT fitting without resorting to a mating thread fit. A soldered joint is preferred over a weld or braze because less heat input is required. As a consequence there is less risk of damage to the threaded joint, or the nearby bi-braze joint.

The three other ports into the LN2 reservoir (LN2 Inlet, GN2 Vent and Regen GN2) are ASA-5-200N type fittings. The ASA flange is an ANSI flange standard with an elastomeric o-ring seal and can be used for vacuum applications⁵. The LN2 Inlet and Regen GN2 ports can be capped with an ASA blankoffs. Without the LN2 there is no longer a need for the Rupture Disk (4.5" OD CF), so this can be removed and the port connected with a UHV flexible hose to the GN2 Vent port (which has the least resistance into the reservoir). In order to accomplish this connection the following parts are needed:

³ Christopher David, Michael Coplan, *Building Scientific Apparatus*, Cambridge University Press, pg. 118.

⁴ I.R. Walker, *Reliability in Scientific Research: Improving the Dependability of Measurements, Calculations, Equipment, and Software*, Cambridge University Press

⁵ Although rated for pressures of $\sim 10^{-7}$ torr (lesker.com) to $\sim 10^{-8}$ torr (mdcvacuum.com), these o-ring sealed joints should be no worse than the o-ring sealed viewports that we employ for high optical quality windows. The LIGO vacuum system can handle the air diffusion from a few more o-rings.

- One (1) ASA-5 to CF275 Conical Adaptor Nipple (e.g. [Lesker PN AF0275XAS5G](#))
- One (1), braided stainless steel hose 36” long with 2.75” OD CF fittings (e.g. [MDC PN 440030](#))
- One (1) CF450 to CF275 straight tube, nipple reducer (e.g. [MDC PN 402013](#))
- Two (2) ASA-5 blankoff fittings (e.g. [MDC PN 160022](#))
- Two (2) Plugs

4 Work Plan

After the issues are resolved, the following work must be accomplished:

1. Assign staffing to conduct the effort. Develop a resource loaded plan and schedule.
2. Perform a Failure Modes and Effects Analysis (FMEA) for the work to be performed, especially the heating of the pumps and the potential for bi-braze joints to fail.
3. Repair regeneration system - known and unknown problems. Ambient air vaporizer has broken welds.
4. Design the control measures and tooling to be employed to isolate the vacuum in the event of a bi-braze joint failure. Conduct a design review prior to fabrication and procurement.
5. Fabricate and procure the required tooling, components and equipment.
6. Design a vacuum piping tree to allow for mounting an RGA to the mid-station volume and procure the parts.
7. Conduct an RGA scan of the current condition of the cleanliness of the mid-station vacuum volume.

5 Implementation concerns

We need a fail-safe method for decommissioning/warming the cryopumps before proceeding, as outlined above, before proceeding

We need to consider the potential impact of a gate valve failure causing an unscheduled stop work on aLIGO commissioning activities at LHO