

# ALS CHALLENGE

## STUDY OF GREEN LASER TRANSMITTED POWER DECAY



BY NUTSINEE KIJBUNCHOO • THOMAS ABBOTT • GABRIELA GONZÁLEZ

ALS = "Arm Length Stabilisation"

### WHAT'S THE PROBLEM?

The power of the green laser (532nm wavelength) transmitted through the x-arm cavity quickly decays after the interferometer locking loops are turned off (no locking activity), and no one knows why.

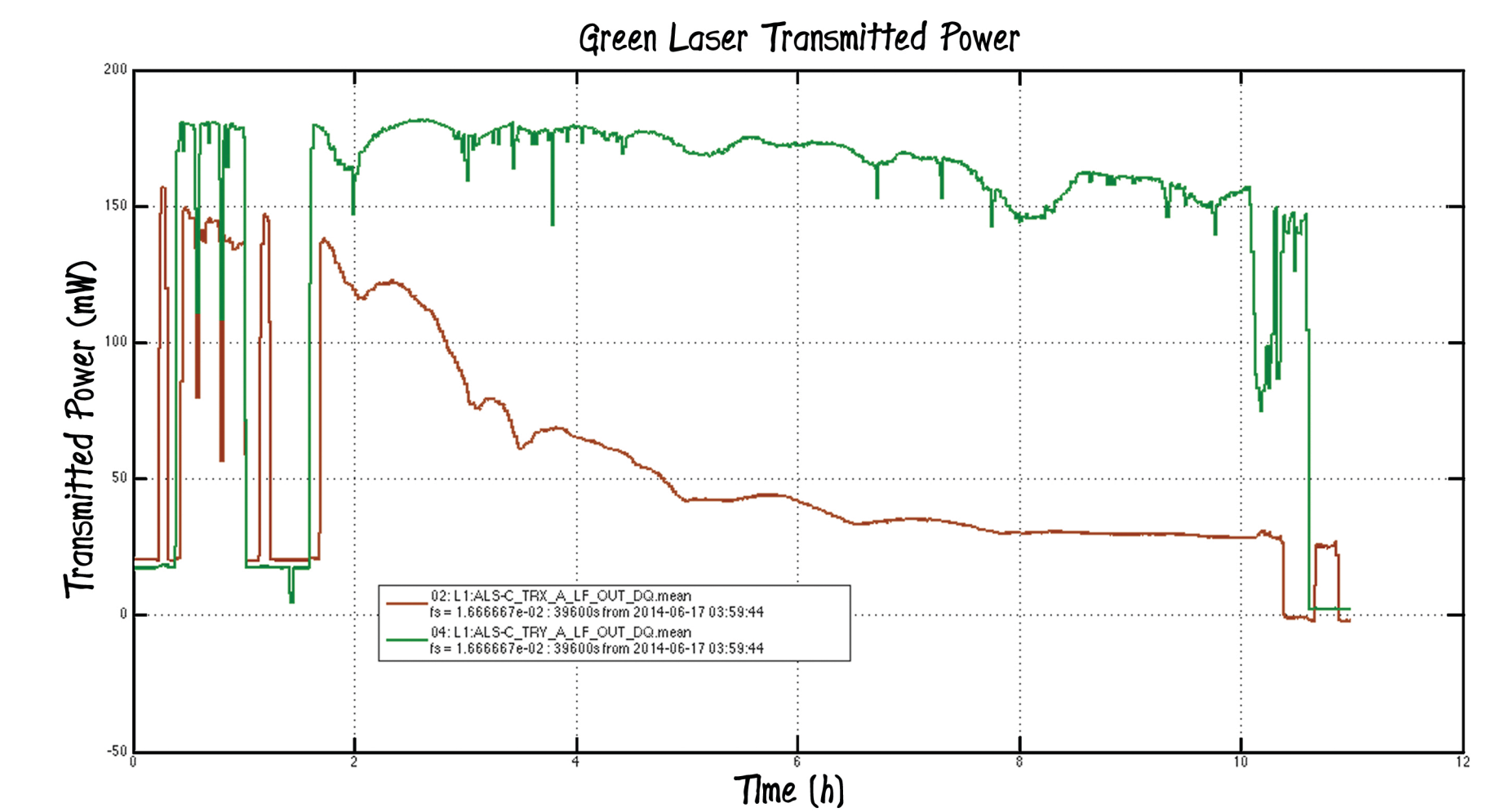
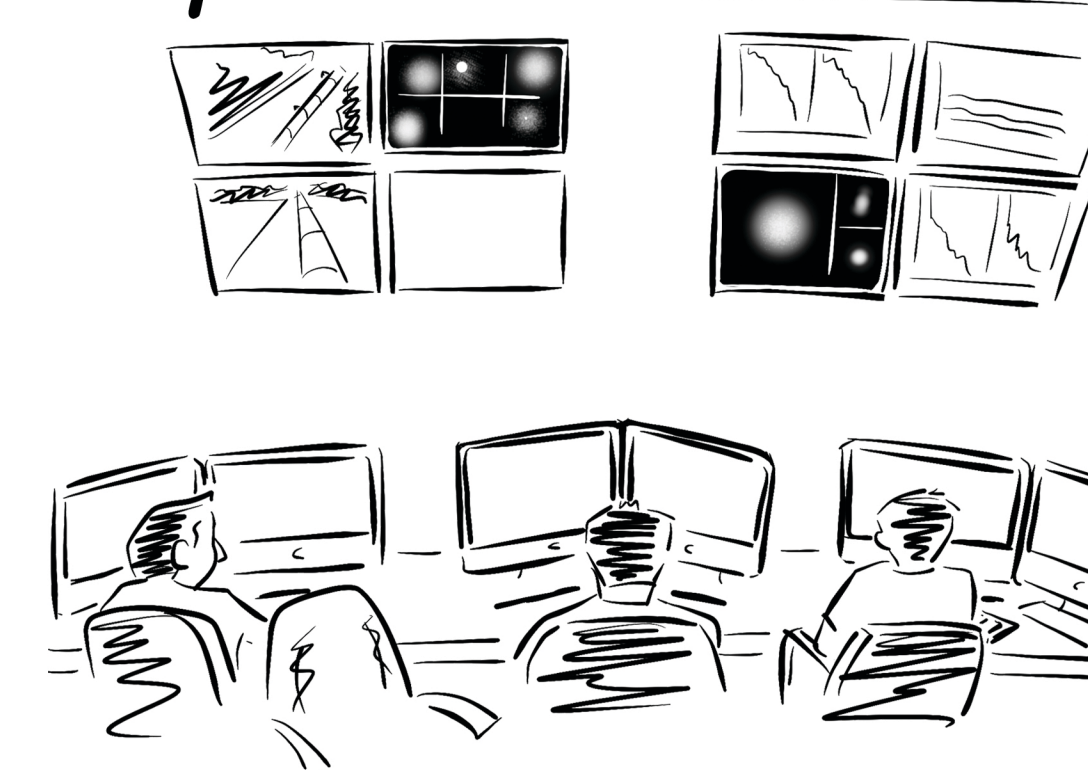

### WHY DO WE CARE?

Figuring out what causes this will help us understand the sources of alignment drift, which is important for the alignment and locking process.

### IT'S NOT THE INPUT POWER!

At any instant in time, the power transmitted from the arm cavities will be proportional to the power inputted

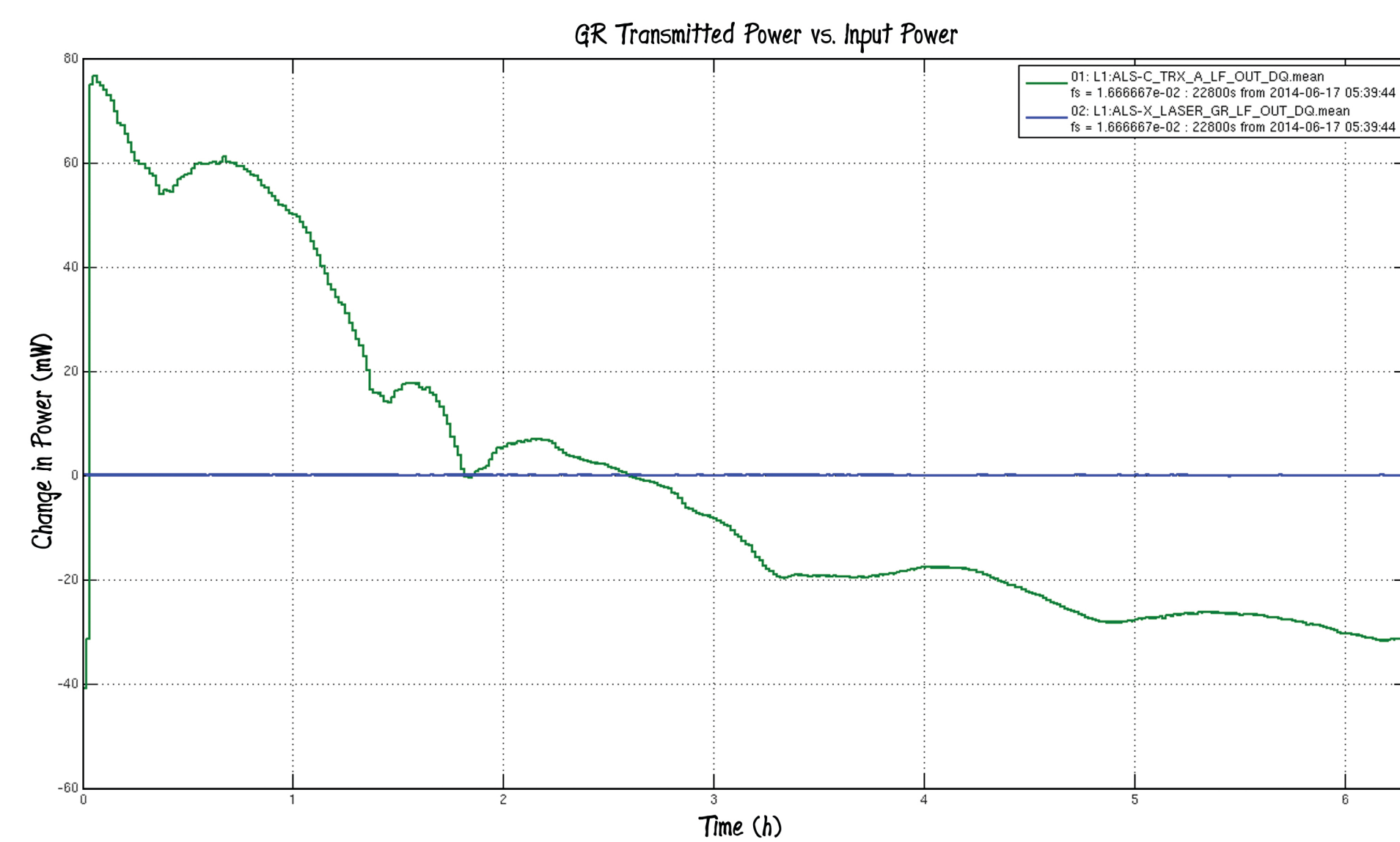

This plot shows the power from the laser vs time on June 17th. It can be seen that the power does not decay, so we can rule out the input power.

### AND IT IS NOT THE TEMPERATURE...

Decay persists even after temperature in corner station and end stations were stabilized.

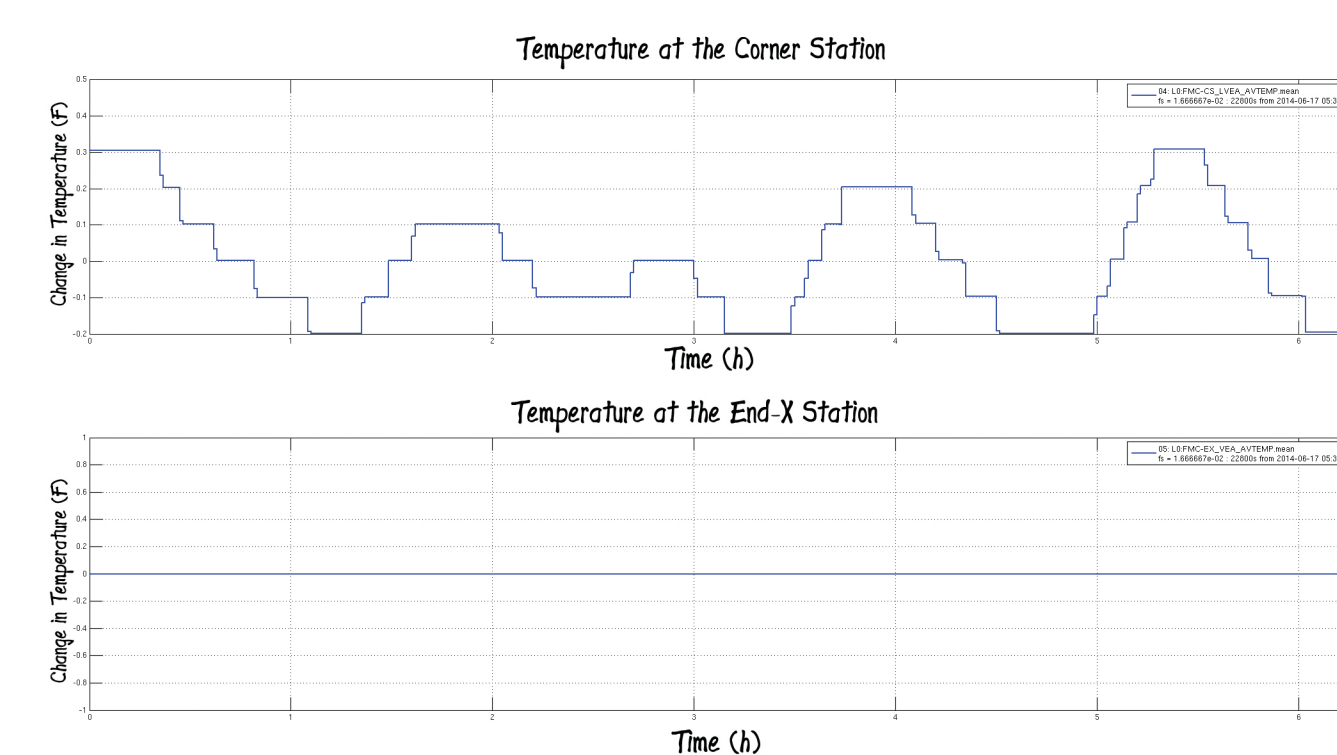

Temperature fluctuates with roughly 30 min period, yet transmitted power takes 2-4 hours to decay.

The vertical sag of optics from thermal expansion of suspension blade springs that we observe is consistently only a couple of microns.

How do we know vertical sag is not the cause of the transmitted power decay we observe? On July 17th, both the TMSX and the ETMX suspensions sag about 3um, while the transmitted power drops to ~30%. Likewise on July 20th, both the TMSX and the ETMX suspensions sag only 0.5um, but the transmitted power again drops to ~30%.

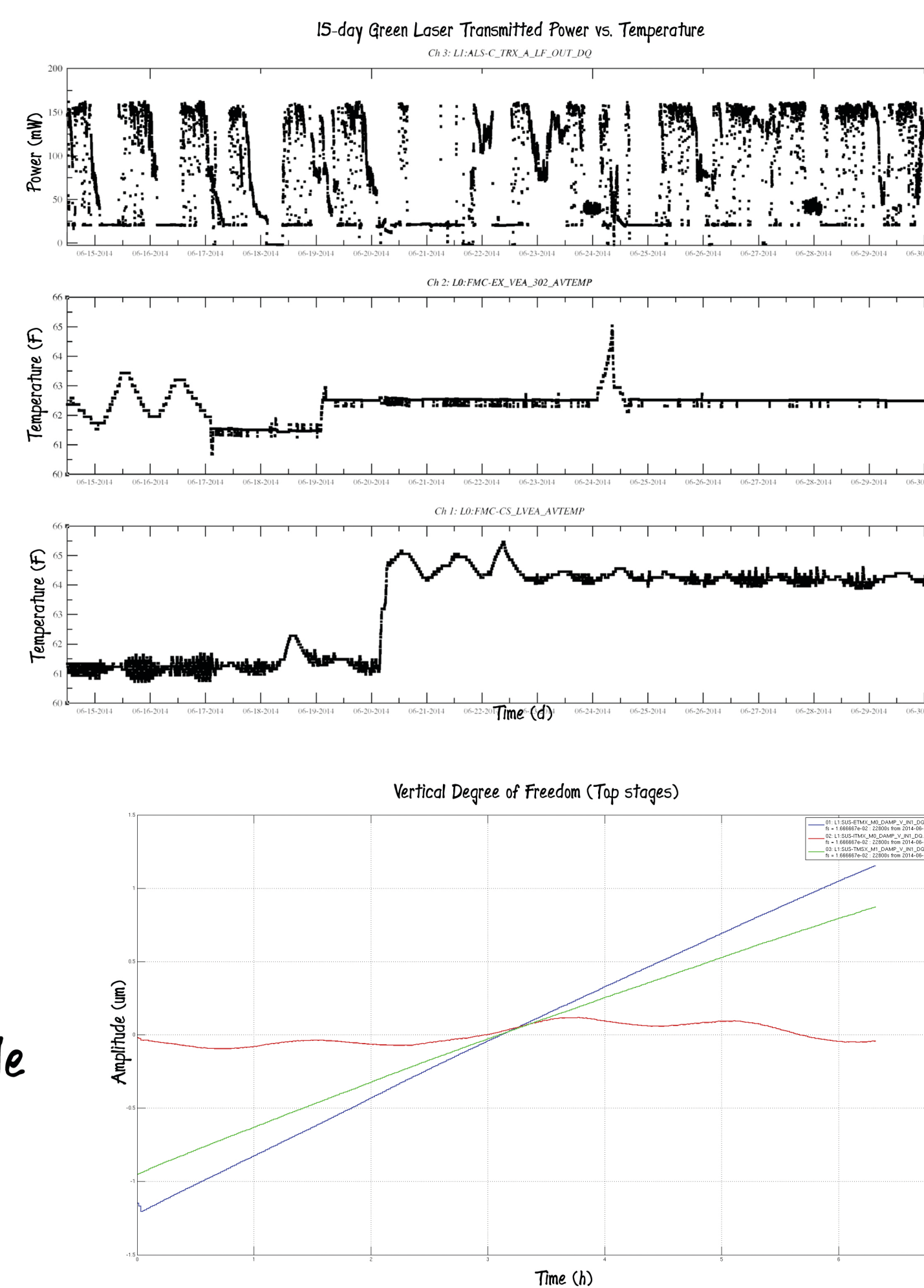

### OUR SUSPECTS

Since the problem clearly occurs within the cavity before the green beam reaches the photodetector at the corner station, we have narrowed down our suspects to systems within BSC 3 and BSC 4.

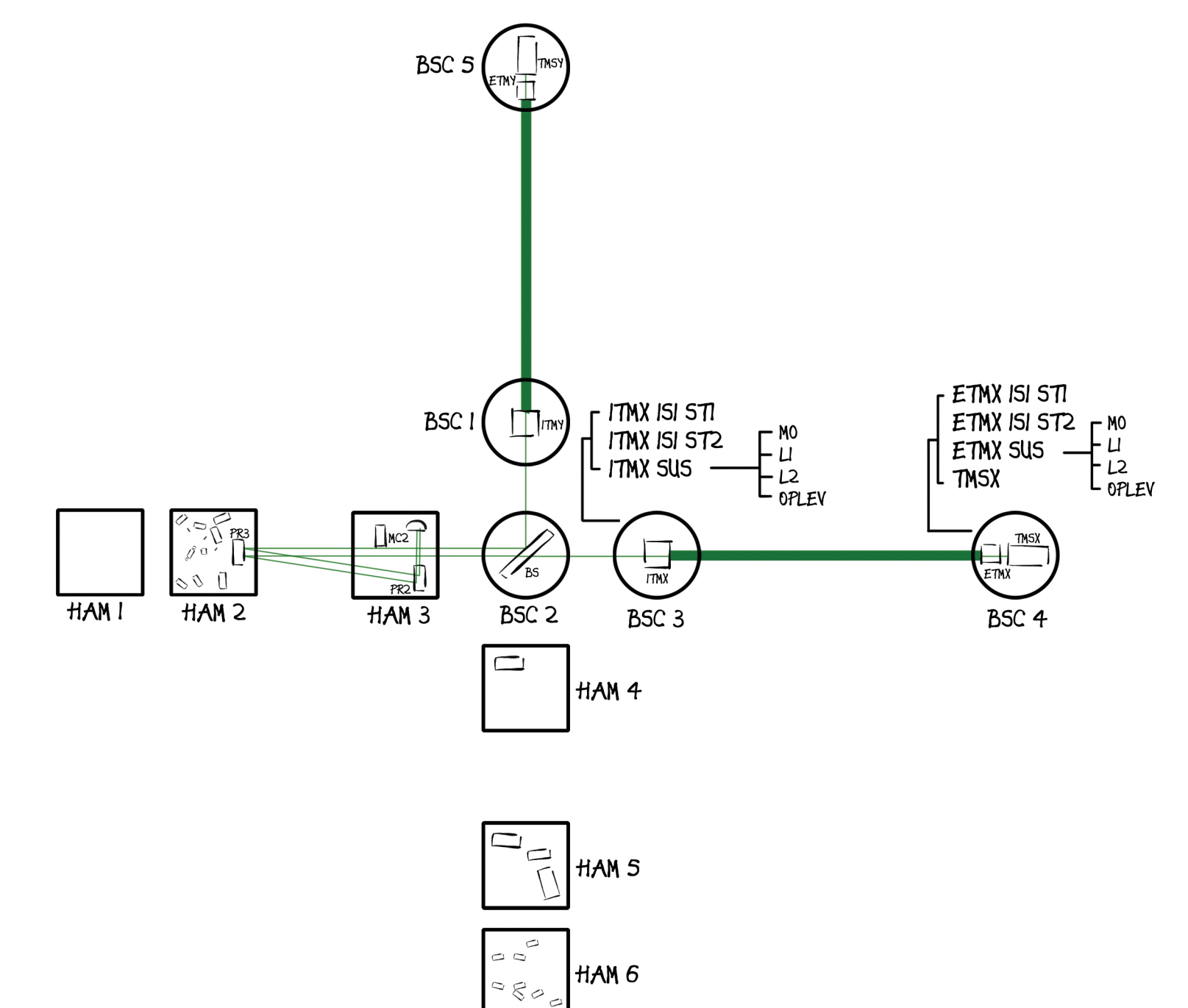

### SOMETHING INTERESTING WE HAVE FOUND

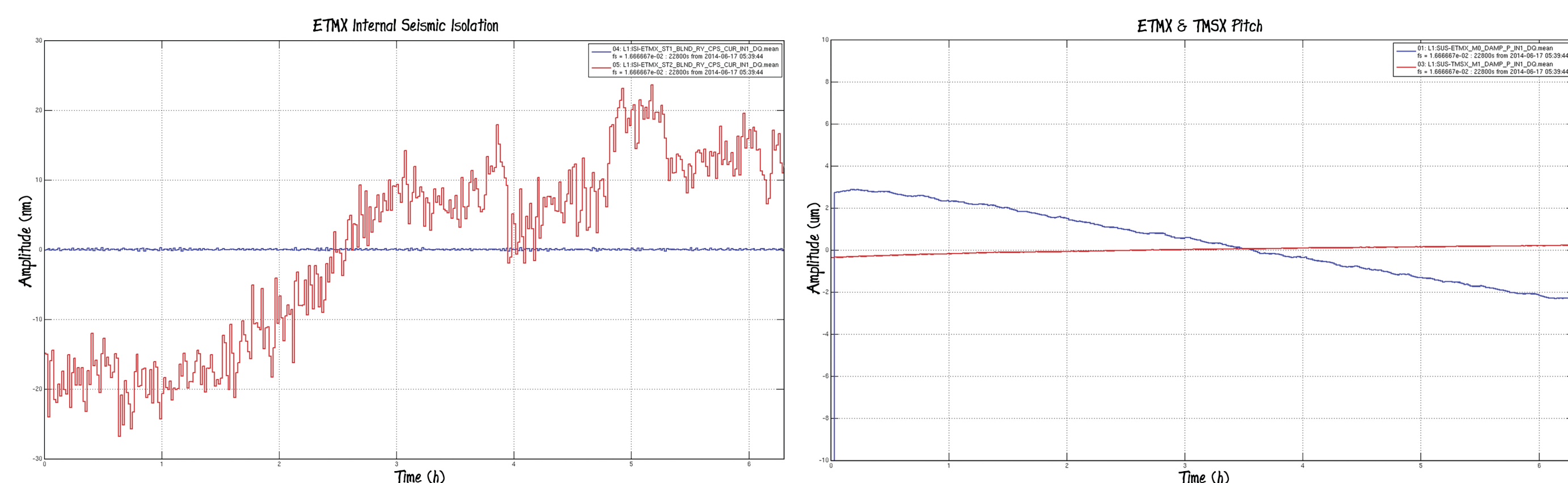

(Left) Internal Seismic Isolation (ISI) stage 1 (ST1) and stage 2 (ST2) rotation about the y-axis, which along the x-arm corresponds to the pitch degree of freedom of the test mass. (Right) Pitch of the top stage of the x-end test mass quadrupel suspension (ETMX) and the x-end trans-monitor double suspension (TMSX). Notice ISI ST1 is stable throughout the time of green laser transmitted power decay while ISI ST2 steadily pitches upward, and similarly the TMSX stays relatively stable while the ETMX pitches downward. Or does it? Appearances can be deceiving as we explain in the next panel...

### WHAT WE THINK IS HAPPENING

The quadrupel suspensions that hold the test masses are hung from two wires separated transversally to the beam path, so when the ISI pitches gravity keeps the suspension chain vertical. However, since pitch of the top stage is measured relative to the frame surrounding the suspension, the sensors record a change in pitch opposite to the pitch of the ISI.

The transmon double suspensions, which inject the green laser into the cavity through the end test mass, are hung from two wires that are separated longitudinally to the beam path, so when the ISI pitches, the transmon pitches along with it.

This effect would cause an initial misalignment of the laser entering the arm cavity, and we suspect it is causing the decay in transmitted power that we observe on a regular basis.

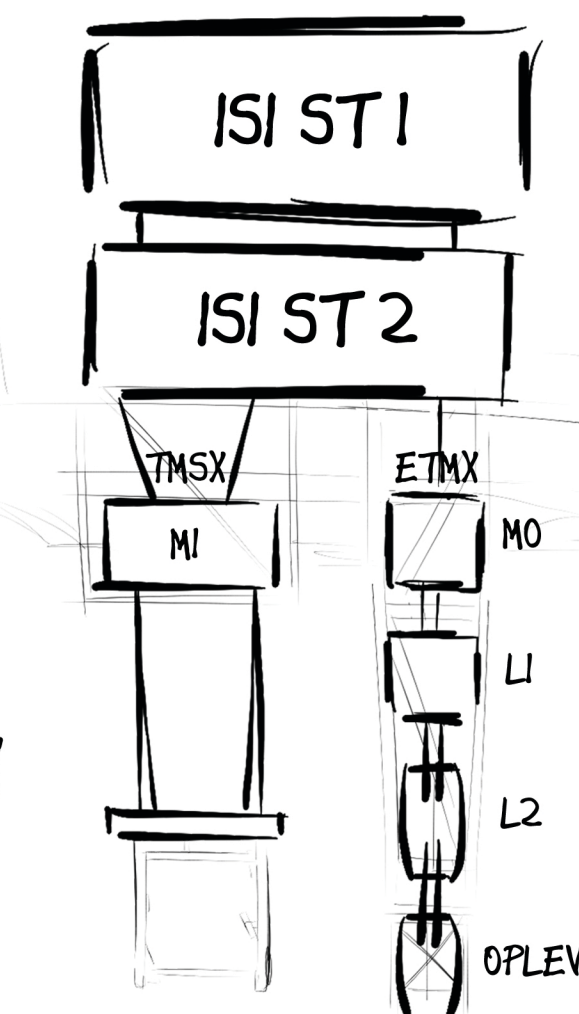
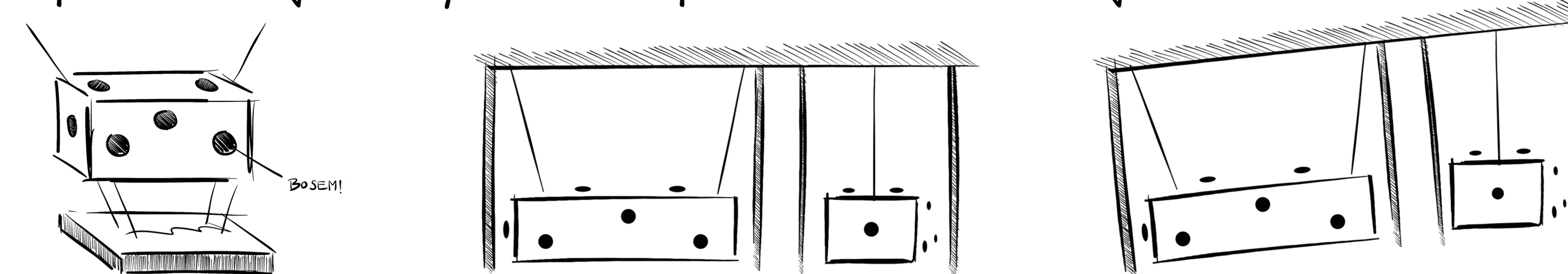

### WHAT'S NEXT?

We have been working on untangling this problem more quantitatively by modeling the transmitted power of the arm cavities by inputting the angular misalignment of the test masses using optical lever data.



I would like to acknowledge the Detector Characterization Group, Brian Lantz and the SEI group, LIGO-Livingston, and everyone who has been putting up with us. And thank you NSF support with award PHY-1205882

