

LASER INTERFEROMETER GRAVITATIONAL WAVE OBSERVATORY

-LIGO-

CALIFORNIA INSTITUTE OF TECHNOLOGY

MASSACHUSETTS INSTITUTE OF TECHNOLOGY

Document Type	DCC Number	Aug 31, 2014
Test Procedure	T1400260-v4	
TCS CO2 Laser Photodiode Preamp Test Procedure		
B. Abbott		

Distribution of this draft:
This is an internal working note of the LIGO Laboratory

California Institute of Technology
LIGO Project – MS 18-33
Pasadena, CA 91125
Phone (626) 395-2129
Fax (626) 304-9834
E-mail: info@ligo.caltech.edu

Massachusetts Institute of Technology
LIGO Project – MS 20B-145
Cambridge, MA 01239
Phone (617) 253-4824
Fax (617) 253-7014
E-mail: info@ligo.mit.edu

<http://www.ligo.caltech.edu/>

Performed by: _____

Date: _____

Board Serial Number: _____

1. Overview

The Thermal Compensation System (TCS) CO₂ Laser Photodiode Preamp is part of the Intensity Stabilization Servo loop. The tests below are intended to determine that the photodiode preamp is functional before inserting a photodiode.

2. Test Equipment

- 2.1 Power Supply capable of +/- 15V
- 2.2 Digital Multimeter (DMM)
- 2.3 SR785 network analyzer, or equivalent
- 2.4 Voltage Calibrator, or adjustable power supply

3. Preliminaries

- 3.1 Perform visual inspection on board to check for missing components or solder deficiencies
- 3.2 Before connecting the power to the chassis, set power supplies to +/- 15 Volts then turn them off. Connect the power supplies to the back panel 9-pin Dsub connector with +15V (VCC) attached to Pin3, -15V (VEE) attached to Pin8, and GND attached to Pin4 (see Figure 1, below).

Figure 1.

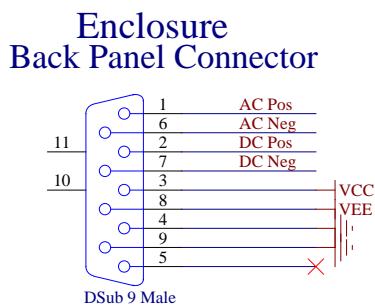

4. DC Tests

4.1 Turn on the +/- 15V power supplies to the PD Box. Record the total current.

Measure	Expected Current	Observed Current
+15V Supply	60mA +/- 10mA	
-15V Supply	60mA +/- 10mA	

4.2 Using a voltage calibrator and digital multimeter verify the DC gain on the monitor SMA and the back panel DSub pins in the table below.

Input 40mV	Output	Expected Value	Voltage Correct?
“Test In” SMA 40mV	“DC Mon” SMA	-10.2V +/- .2V	
“Test In” SMA 40mV	Dsub Pins 2(+) and 7(-)	+20.4V +/- .4V	

5. Frequency Response and Noise Tests

5.1 **DC Coupled Frequency Response:** Using a Network Analyzer, do a swept sine measurement from 10Hz to 100KHz. Set the source to 1mV, and read the output on the monitor SMA, and the differential Dsub pins as shown in the table below.

Input 10mV	Output	Expected Value	Function Correct?
“Test In” SMA 1mV	“DC Mon” SMA	A flat 48.1dB (+/- 0.1dB) gain from 10 Hz out to 100KHz	
“Test In” SMA 1mV	Dsub Pins 2(+) and 7(-)	A flat 54.15dB (+/- 0.2dB) gain from 10 Hz out to 100KHz	

5.2 AC Coupled Frequency Response: Change the source to 1.0mV, and pass it through 60dB of attenuation. Set the marker to “Normal” width, and seek “Mean”. First, take the output of the attenuators, and loop it back to Channel 2A, and read the actual amount of attenuation in Swept Sine mode.

Enter attenuation in dB: _____

Now hook up the output of the attenuators to the PD Test Input (see Figure 2, below). Read the output on the monitor SMA, and the differential Dsub pins as shown in the table below. When filling out the table below, remember to add the attenuation recorded above to the numbers read from the Network Analyzer screen. The transfer function should look like Figure 3, below.

Input (1.0mV)	Output	Expected Value	Function Correct?	Gain at 500Hz?
“Test In” SMA 1.0mV	“AC Mon” SMA	A zero at DC, Pole at 20Hz, a gain of 99dB (+/- 1 dB) between 400Hz and 5KHz, and a HF pole		
“Test In” SMA 1.0mV	Dsub Pins 1(+) and 6(-)	A zero and DC, Pole at 20Hz, a gain of 105dB (+/- 1dB) between 400Hz and 5KHz, and a HF pole		

SR785 Setup:

(Be sure to tie both black leads of The test leads to GND on the Board)

Figure 2.

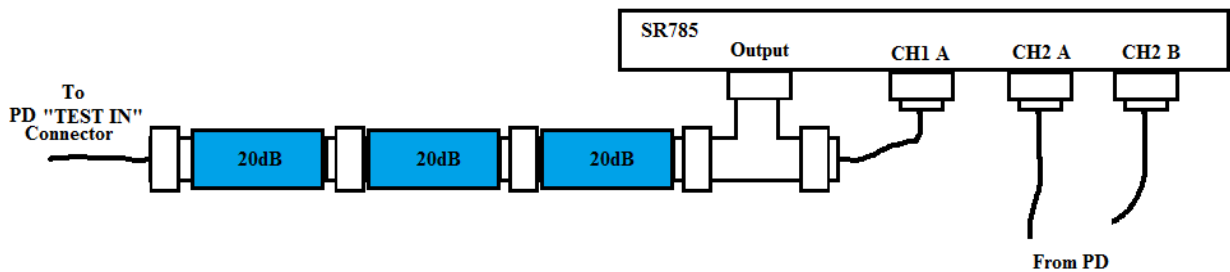

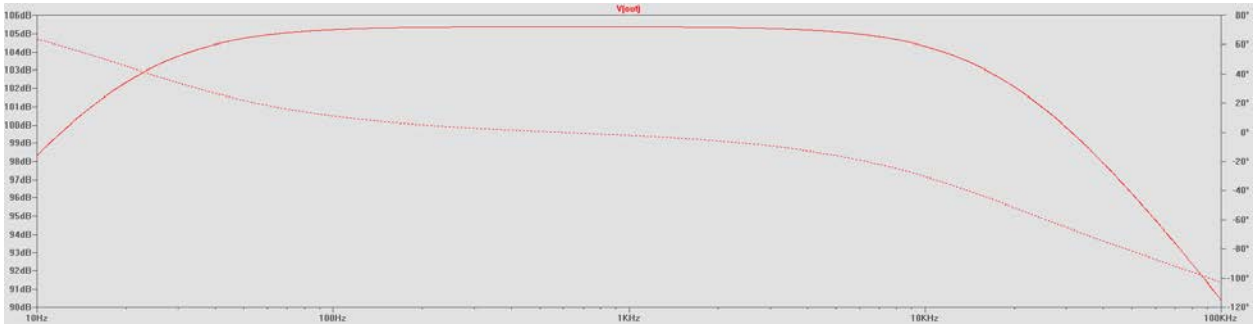

Figure 3.

5.3 Noise Levels: Change the Network Analyzer to do an FFT measurement, and keep the marker set to “Normal” width, and seek “Mean”. Put an SMA termination (short to GND) the “Test Input”, and measure the noise (excluding 60Hz, and its harmonics) differentially at pins 1(+) and 6(-), and 2(+) and 7(-) from 4Hz to 3.2KHz.

Input Shorted	Output	Expected Value	Function Correct?
“Test In” SMA	Dsub Pins 1(+) and 6(-) (AC Coupled Path)	Less than $100\mu\text{V}_{\text{rms}}/\sqrt{\text{Hz}}$ above 90Hz that should be flat with frequency.	
“Test In” SMA	Dsub Pins 2(+) and 7(-) (DC Coupled Path)	Less than $300\text{nV}/\sqrt{\text{Hz}}$ above 80Hz	