



LIGO Laboratory

California Institute of Technology
MS 18-34, 1200 E. California Blvd.
Pasadena CA 91125 USA
TEL: 626.395.2129
FAX: 626.304.9834
www.ligo.caltech.edu

LIGO Livingston Observatory
P.O. Box 940
Livingston LA 70754 USA
TEL: 225.686.3100
FAX: 225.686.7189
www.ligo-la.caltech.edu

LIGO Hanford Observatory
P.O. Box 159
Richland WA 99352 USA
TEL: 509.372.8106
FAX: 509.372.8137
www.ligo-wa.caltech.edu

Massachusetts Institute of Technology
MIT NW22 – 295, 185 Albany St.
Cambridge MA 02139 USA
TEL: 617.253.4824
FAX: 617.253.7014
www.ligo.mit.edu

Date:	February 9th, 2014	Refer to:	T1400028-v2
Subject:	HLTS/HSTS Status update		
To:			
From:	Harrison Miller (plus edits from Norna Robertson)		

Introduction:

Triple suspensions, incorporating two stages of vertical springs, are used to provide seismic isolation for various optics in Advanced LIGO, including the optics in the signal recycling cavity. In the current Advanced LIGO design, noise in the signal recycling cavity (SRC) length, coupling into the gravitational wave readout through radiation pressure, may be a greater noise source than we would like. In particular vertical noise in the SRC suspensions which couples into horizontal motion is expected to give noise higher than our technical noise limit. This is due to the fact that the highest vertical mode of the SRC triple suspensions is relatively high—approximately 28 Hz—and is in the gravitational wave band. This noise source could be addressed with the modification of adding an additional stage of cantilever blade springs into the triple suspension, to bring the highest vertical mode to below 10 Hz. This requires a new design of the middle mass to incorporate the new blade springs.

Completed Work:

There are 3 suspensions used in the signal recycling cavity: two HAM Small Triple Suspension (HSTS) and one HAM Large Triple Suspension (HLTS), all of which contribute to the noise in the cavity. Initial work was focused on reducing the noise of the HLTS. Substantial work has already been done by Kristen Holtz in redesigning the middle mass of the HAM Large Triple Suspension (HLTS). The new mass was essentially a copy of the top mass, with major modifications to allow for the connection of four wires from above rather than two (fig. 1). However, these modifications made major changes to the mechanical parameters of the middle mass such moment of inertia and size. The most notable changes were the new lengths of the wires running to and from the middle mass, the angles of the wires from middle to bottom mass, their separation in the direction orthogonal to the face of the optic, and the change in vertical compliance from the addition of a new set of blades. We calculated the parameters for the new blades using a spreadsheet calculator based on those used for modeling the aLIGO blades (e.g. T1000353 for HLTS).

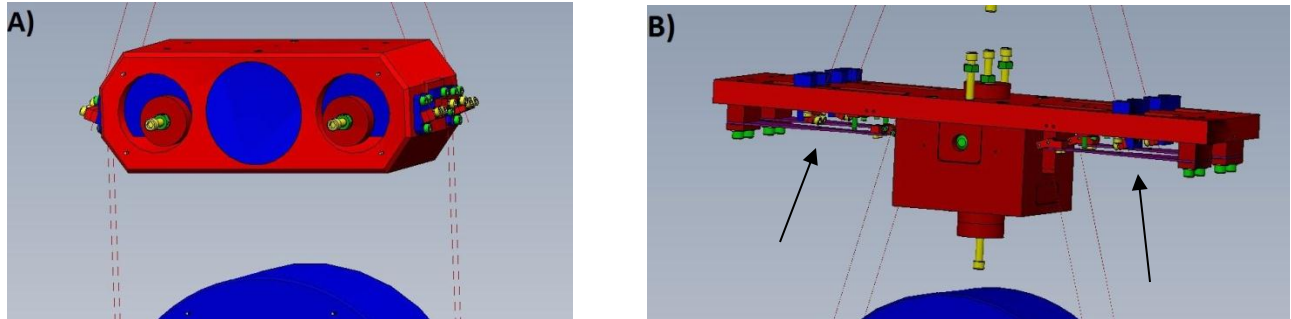

Figure 1: Original middle mass (A) and updated middle mass (B) for the HLTS. Note the added blade springs (labeled with arrows) and drastic changes in size, shape, wire length, etc.

The next step was to then model the seismic noise transfer functions of the new suspension in MATLAB, using the new parameters, to ensure that adding the extra set of blade springs would have the desired effect of bringing the vertical mode to below 10 Hz. Transfer functions for the new model were plotted with ones for the old model for comparison. As seen in the plots below (Fig. 2), the addition of the new stage of blades successfully lowered the vertical mode down to about 5 Hz.

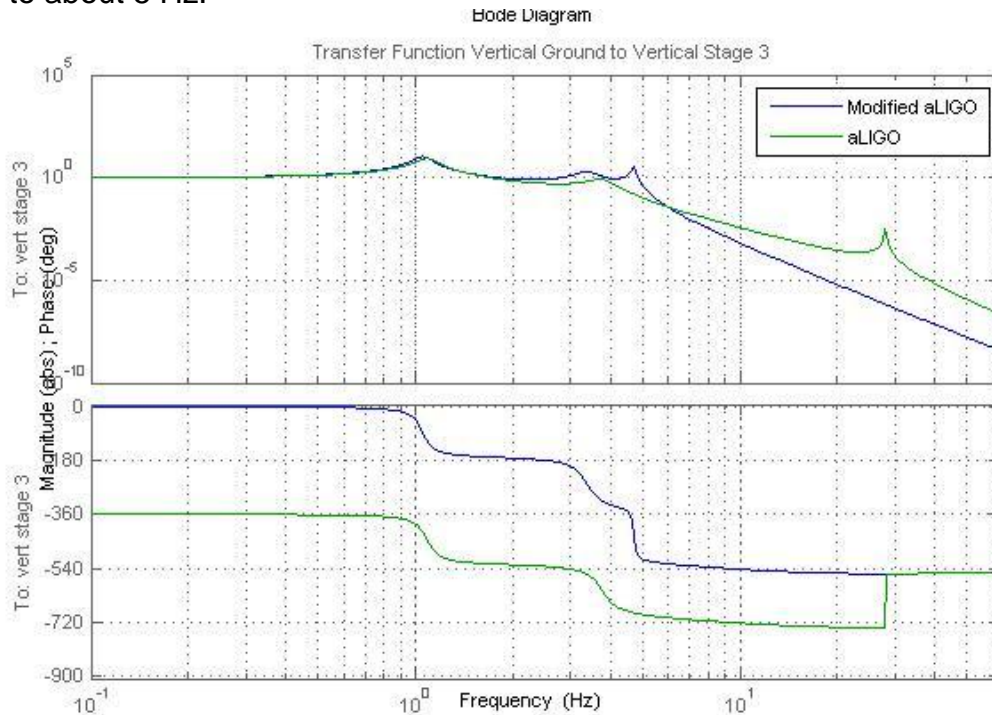

Figure 2: Transfer function of Vertical Suspension Point to Vertical Stage 3. Note that the peak for the highest vertical mode has been pushed back under 10 Hz.

After this work on the HLTS was completed, it was recognized that it would be more important to focus our redesign work on the HSTS because one if the HSTS mirrors in the cavity is pitched to align the cavity and this increases the vertical to horizontal coupling. Hence motion of this suspension introduces more vertical noise into the cavity than the other two suspensions. We carried the same methods used in redesigning the HLTS over to the

HSTS by first copying the design of the top mass for a new middle mass. However, the top mass as it stood would not allow for the use of actuators on the middle mass as currently positioned. So, it was clear that some modifications needed to be done. As a proof of concept, we added a bottom plate that would allow for the same actuator placement as the old middle mass. We also changed the material of the bottom pieces from steel to aluminum in an attempt to keep a similar total mass as well as center of mass (fig. 3). It became apparent that, not only were there various ways to allow for the proper actuator placement, but accommodations also needed to be made for the attachment of two new wires on top as well as the blades on the bottom.

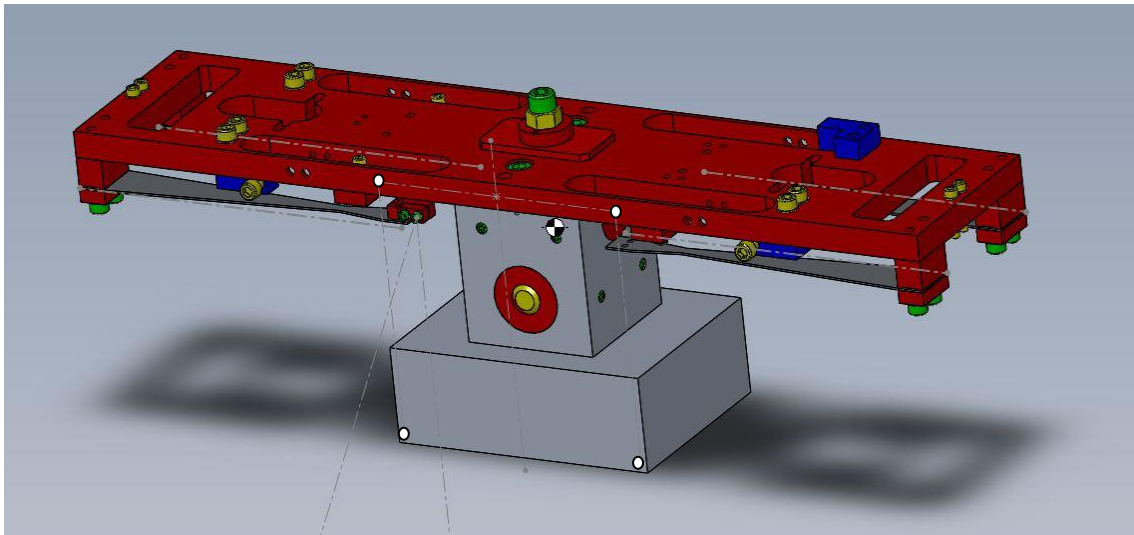

Figure 3: Proof of concept for new HSTS middle mass. Grey lines mark position of wires and white dots marking OSEM magnets

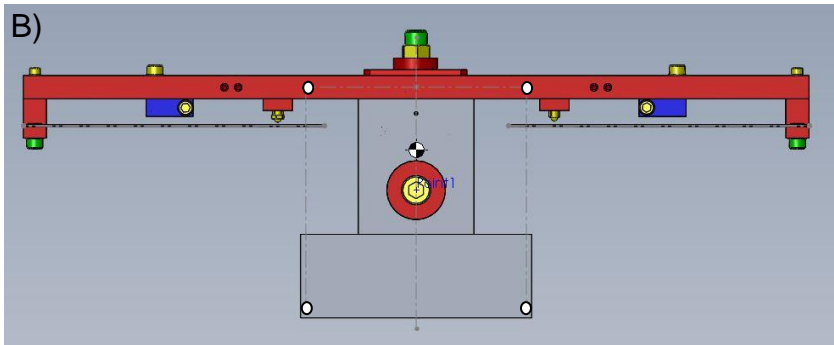
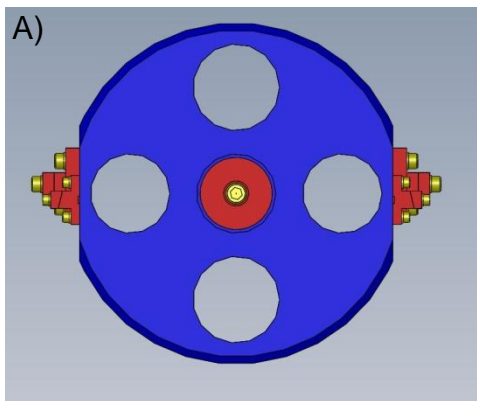

Figure 4: A) Old middle mass

B) new middle mass

	Original			New		
Moment of Inertia (g*mm ²)	Lxx = 8237.979	Lxy = 0.001	Lxz = 0.000	Lxx = 4840892.64	Lxy = 1816.01	Lxz = 0.21
	Lyx = 0.001	Lyy = 9851.735	Lyz = 0.003	Lyx = 1816.01	Lyy = 19436438.90	Lyz = 227.89
	Lzx = 0.000	Lzy = 0.003	Lzz = 13777.077	Lzx = 0.21	Lzy = 227.89	Lzz = 21778907.19
Mass (Kg)	2.981743			2.5312		

Figure 5: data from original middle mass and new middle mass. This first redesign has drastically changed the mass properties of the mass

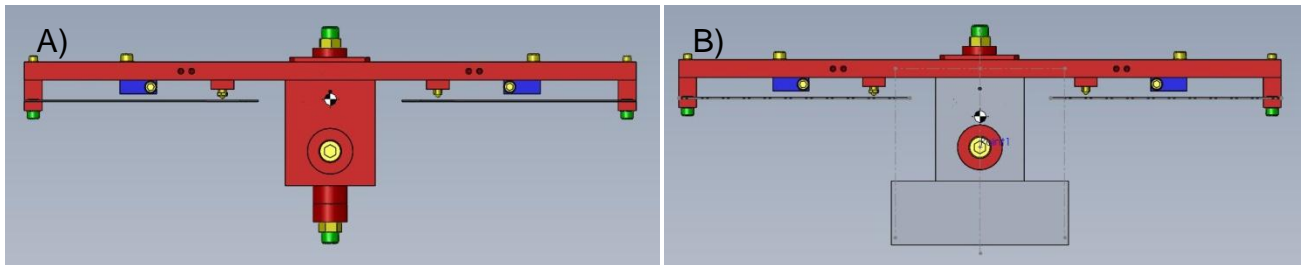

Figure 6: A) Original top mass and B) redesigned middle mass. The bottom piece was added to accommodate OSEM magnets. However, even after changing the material from stainless steel (red) to aluminum (grey), the center of mass has still been shifted too far below the blades.

Work to be done:

Before settling on a design for the new middle mass of the HSTS, we must weigh all of the design options to see which will be the most beneficial. Some considerations are more crucial than others, and many interfere and coincide with others. One solution is to use a design matrix to determine the design that fulfills all of the requirements with the least amount of redesign work.

Considerations include:

- **Mass of new design**
 - We need the new design to have the same mass as the original so that we do not have to worry about redesigning the blades above the middle mass
- **The shape and resulting moment of inertia of the mass**
 - Changing the moment of inertia can have an effect on the mode frequencies, so we need to make sure the resulting damping and transfer functions are still sufficient
- **The placement of OSEM magnets**
 - Ideally, we would want to have a design that allows for the original placement of OSEMs.
 - However, due to the constraints on moment of inertia and, in turn, shape, this may prove difficult.
- **The center of mass with respect to the OSEM magnets and wire break-offs**
 - Having the center of mass an appropriate distance above the bottom wire break-offs and below the top wire break-offs is important for the stability of the new mass (Fig. 7)
 - In addition, the placement of the center of mass with relation to the OSEMs is important for small adjustments to the location of the middle mass, which in turn control the cavity length. We ideally want the center of mass in the middle of the Four OSEM magnets, equidistant from each.

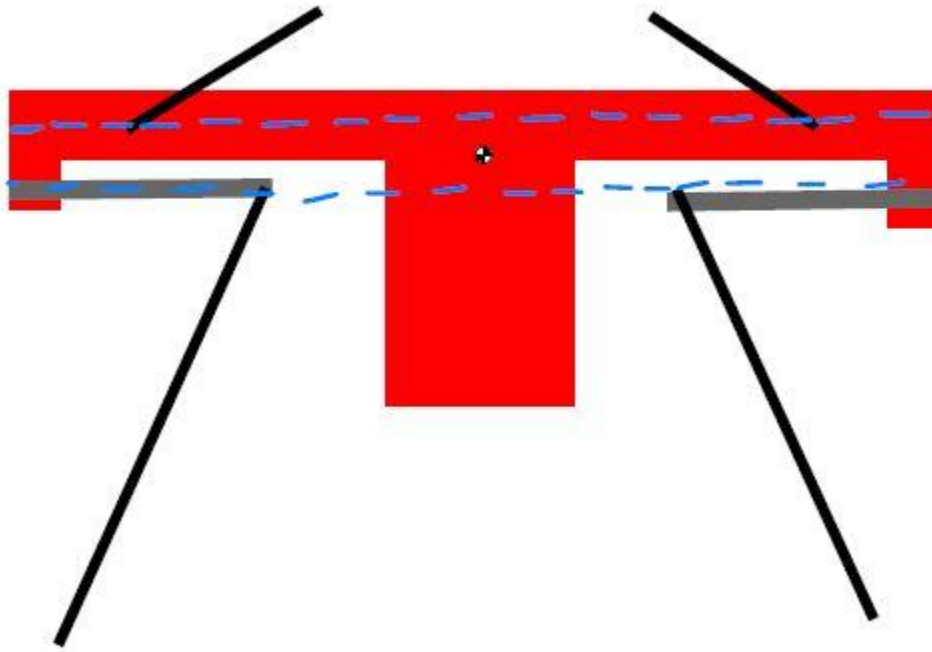

Figure 7: Sketch showing the center of mass in between the two wire break-off planes

- **The wire separation in the direction orthogonal to the face of the optic**
 - Keeping the original wire separation would mean redesign on the bottom mass would be unnecessary
 - This creates a problem with the placement of the newly-added blades
 - We could feasibly add two new blades instead of four
- **Using two blades instead of four**
 - This would allow us to keep the original wire separation
 - This would in turn require a new clamp design to suspend two wires from one blade
- **the vertical frequency of the bottom stage**
 - We need to find a good working frequency for the bottom stage that **a)** still leads to reasonable transfer functions and **b)** can be achieved with a blade of reasonable thickness, length, etc.
- **the new positioning (mainly angle) of the bottom wires**
 - Wires cannot interfere with either the middle or bottom mass (Fig. 8)



Figure 8: The example on the left is unacceptable, because the wires do not have a clean break-off from the prism, as they do in the example on the right