

# aLIGO Output Mode Cleaner: Design, Fabrication, and Installation

Rich Abbott<sup>1</sup>, Koji Arai<sup>1</sup>, Stuart Aston<sup>2</sup>, Sam Barnum<sup>3</sup>, Jeffrey Bartlett<sup>4</sup>, Derek Bridges<sup>2</sup>, Peter Fritschel<sup>3</sup>, Jeffrey Kissel<sup>3</sup>, William Korth<sup>1</sup>, Jeffrey Lewis<sup>1</sup>, Charles Osthelder<sup>1</sup>, Norna Robertson<sup>1</sup>, Sam Waldman<sup>3</sup>

LIGO Laboratory: California Institute of Technology<sup>1</sup>, LIGO Livingston Observatory<sup>2</sup>, Massachusetts Institute of Technology<sup>3</sup>, LIGO Hanford Observatory<sup>4</sup>

LIGO-G1300952



## Abstract

Advanced LIGO employs a DC Readout scheme for sensing of GW signals in order to mitigate laser technical noises. Filtering of undesired optical modes by the output mode cleaner (OMC) is indispensable in order to exploit the benefit of DC readout. The aLIGO OMC was designed based on the success and experience of the eLIGO OMC. The first OMC was built at Caltech and installed in the HAM6 chamber at LLO. The design, fabrication, and installation, as well as the results of the table top performance test, are described in this poster.

## Design of the aLIGO output mode cleaner

### Functions of the OMC

- Remove carrier higher-order modes (HOMs) and RF sidebands from the interferometer output beam => higher cavity finesse preferred
- Transmit carrier TEM<sub>00</sub> mode as much as possible => lower cavity finesse preferred
- Fast shutter action at lock losses of the interferometer.

### aLIGO OMC optical design [1]

- Semi-monolithic structure: "glass prisms glued on a plate" enables fine adjustment of the optical parameters

### Cavity design

4-mirror bowtie ring cavity:  
even mirror cavity for simpler HOM structure

Finesse: ~400 for ~98% transmission  
Length: 1.312m (round-trip) from the breadboard size  
Curved mirror radius: 2.575m  
=> Transverse Mode Spacing (TMS): 0.219 x FSR  
avoids 4th, 5th, as well as 9th HOMs

### Expected filtering performance & tolerance of the cavity length and the mirror RoC

- Based on the eLIGO performance of the IFO optics/TCS Modeled by power laws (details in [2])  
- Expected amount of junk light on the OMC DC PD => turned out to be ~1mW for 100W input  
Well with in the PD capability. Even could be better due to mode healing and better optics in aLIGO

- Cavity length tolerance:  $L=1.132 \pm 0.005$  [m]  
Mirror RoC tolerance:  $R=2.575 \pm 0.015$  [m]

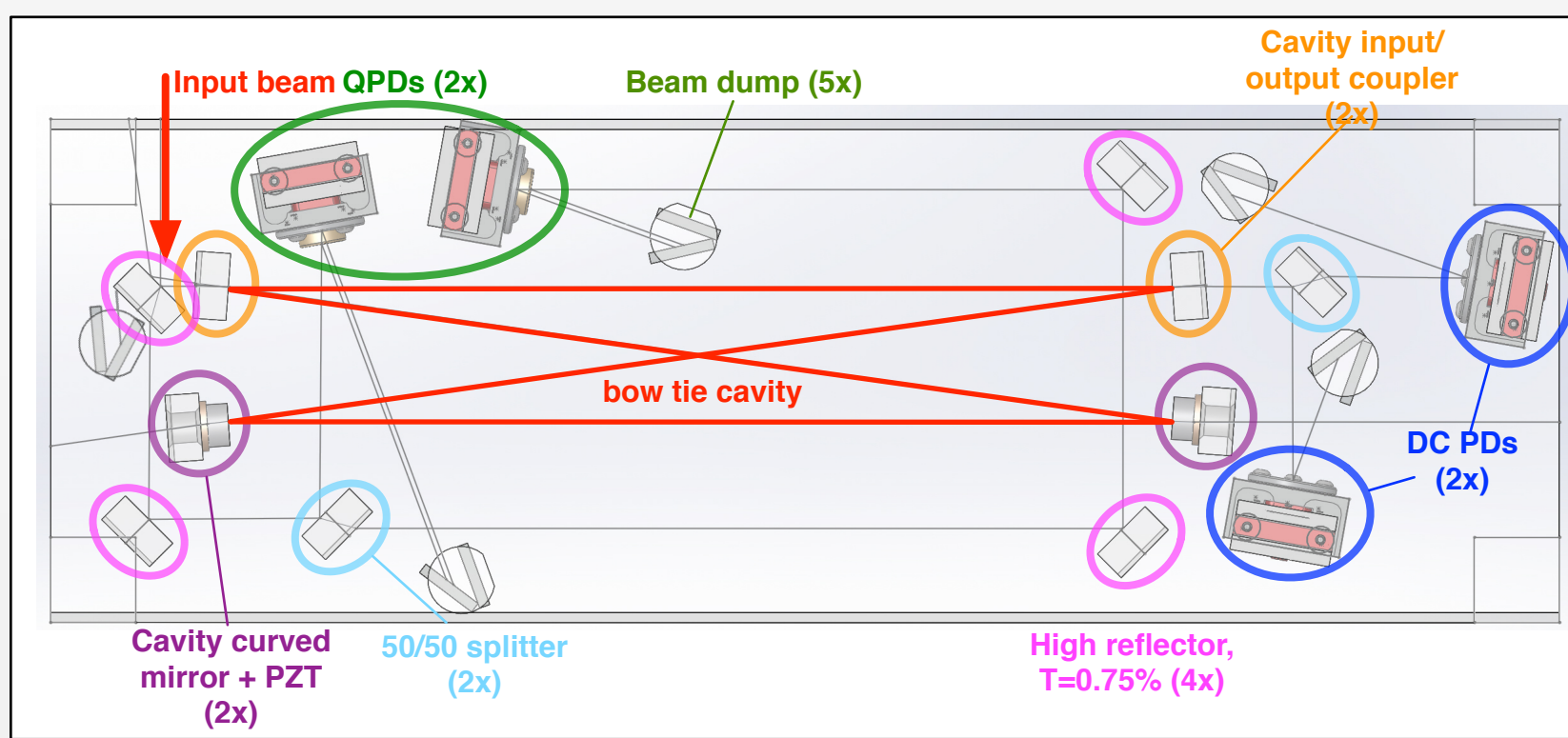

### Comparison between eLIGO -> aLIGO

- Breadboard material:** ULE -> Fused Silica  
=> Easier to manufacture, temperature drift not significant (of the order of 0.1K =  $dL \sim 60$ nm)
- Optics:** Glued on the backside of fused silica prisms  
-> Directly coated on the fused silica prisms (curved mirrors: glued on the front side of the prisms)  
=> Reflecting surfaces easier to clean and observe
- Transverse mode spacing:** 0.235 (Unit: FSR) -> 0.219  
=> More precisely adjusted during the gluing
- Actuators:** A heater on an Al tube and a PZT -> two PZTs  
=> eLIGO experience indicated large actuation range not necessary. One PZT moves more than 5 fringes. Two PZTs increases redundancy.

- Suspension: Double stage OMC suspension -> same  
=> eLIGO suspension is reused with minor modifications

### Peripheral optics and electronics

- DCPDs:  
Two InGaAs photodiodes (Excelitas C3065GH dia. 3mm) at the cavity transmission. **They are where we obtain the GW signals!**  
The housing is mounted on an invar block glued on the breadboard via a height shim. The housing is coated with Alumina for higher emissivity.

- QPD / QPD path:  
0.75% of the incident beam is sacrificed for coarse beam alignment with QPDs. Two QPDs (OSI InGaAs-Q3000) are mounted on the breadboard, same as the PDs.

- Beam dumps:  
Black-glass beam dumps blocks the reflection from the PDs and a stray beam on the QPD path.

### Suspension / Electronics Interface

- Located on the top side of the breadboard
- Wire hooks: Four suspension wires with conical clamps are hooked into glass brackets
- Weight balance: Adjusted by adding weights. Total weight of the breadboard is 7.0 kg.
- Cable stay / cable harness

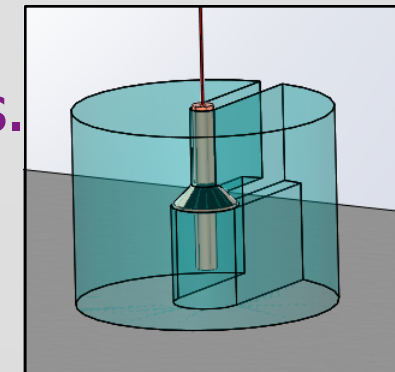

### Estimated contribution of the HOMs and modulation sidebands to the OMC transmission

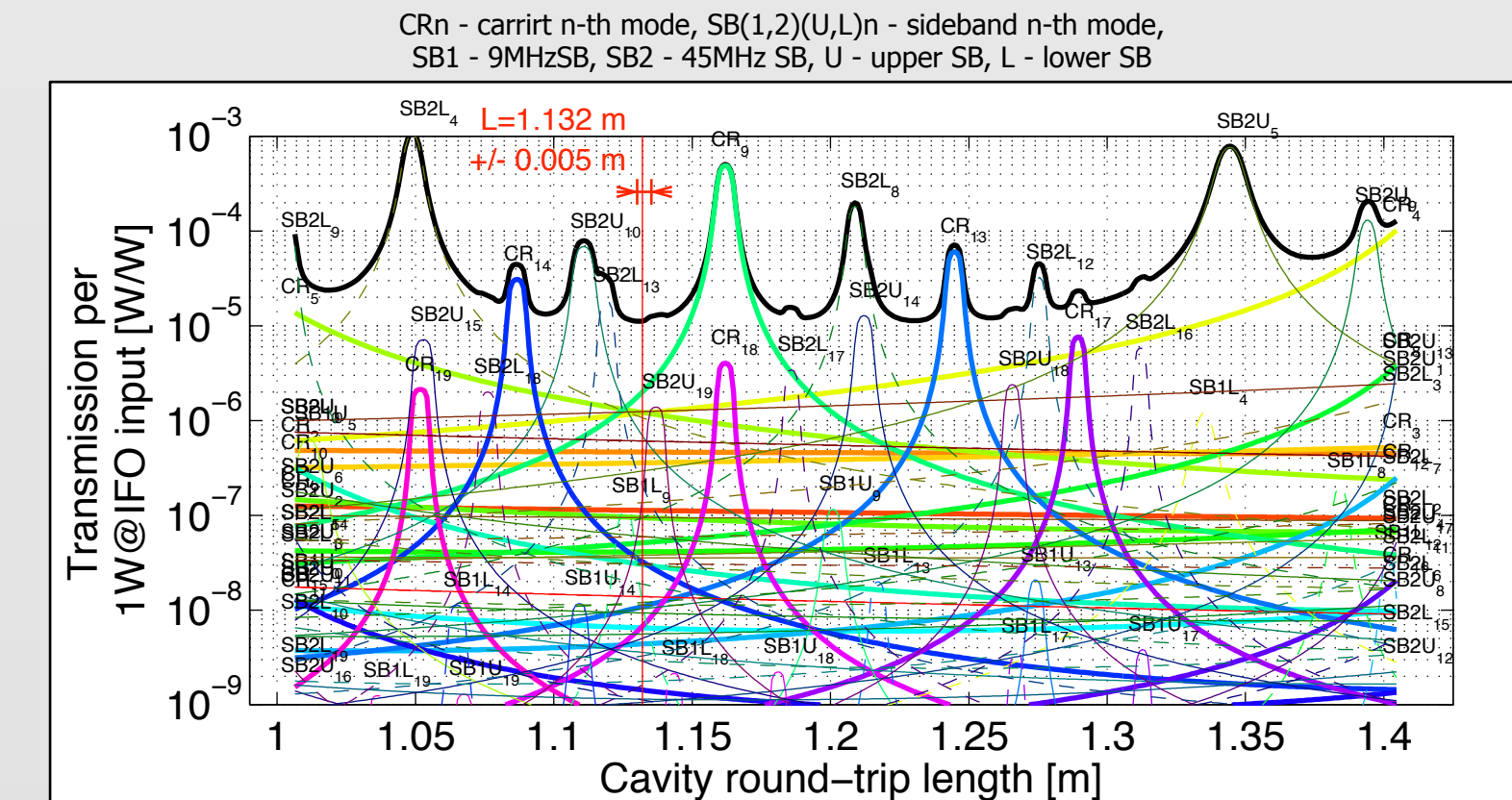

▲ Cavity length tolerance

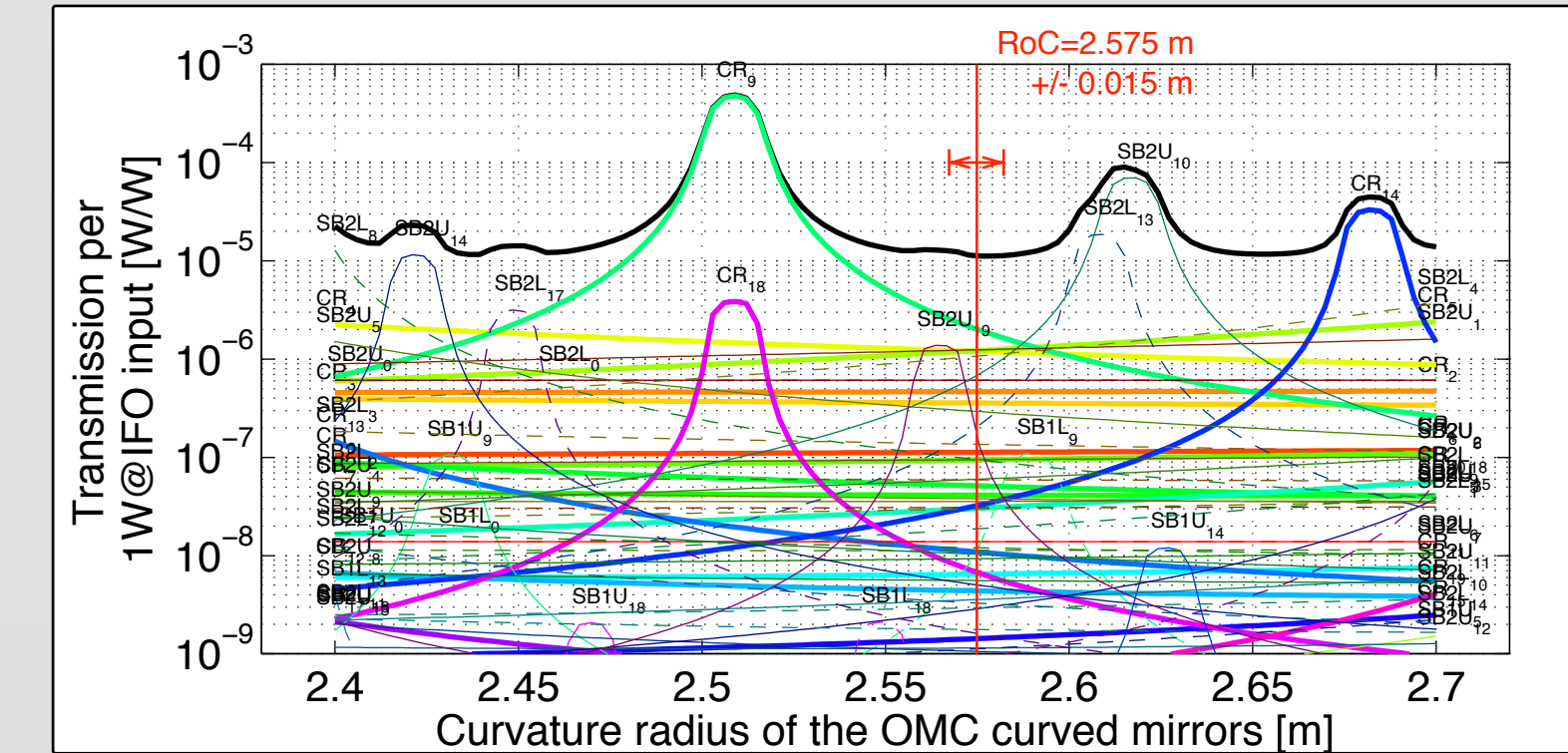

▲ Curvature tolerance for the curved mirrors

## Fabrication

### PZT sub-assembly

- 1/2" curved mirror:  
Glued on a mounting prism together with a PZT
- Bonding:  
Epoxy (Master Bond EP30-2) with borosilicate glass spheres (MO-SCL GL0179B5, 75-90um dia.)
- Wedging of the prisms, PZTs, and curved mirrors:  
Characterized by mechanical or optical techniques  
Arranged to minimize pitch misalignment with regard to the OMC bread board

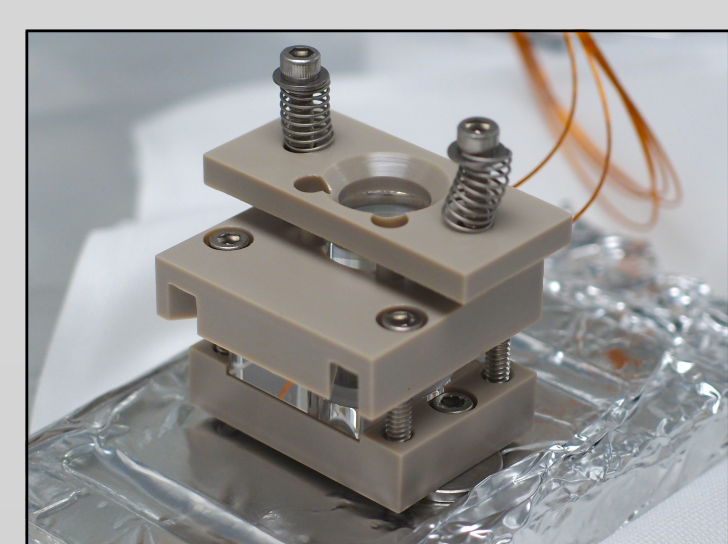
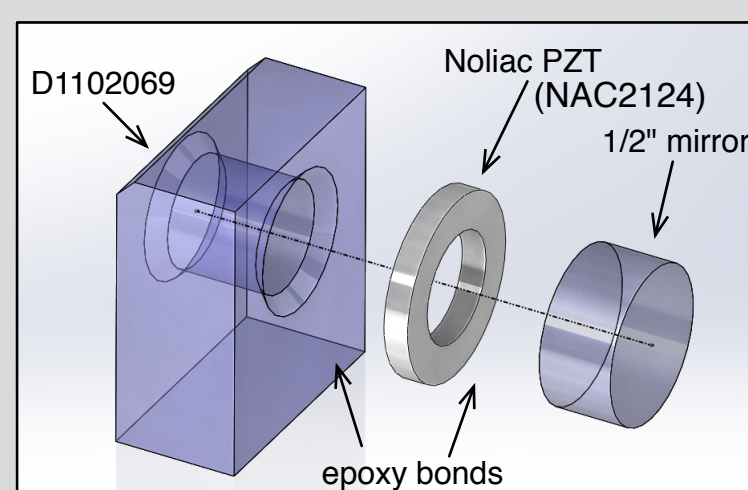

▲ PZT sub-assy gluing fixture

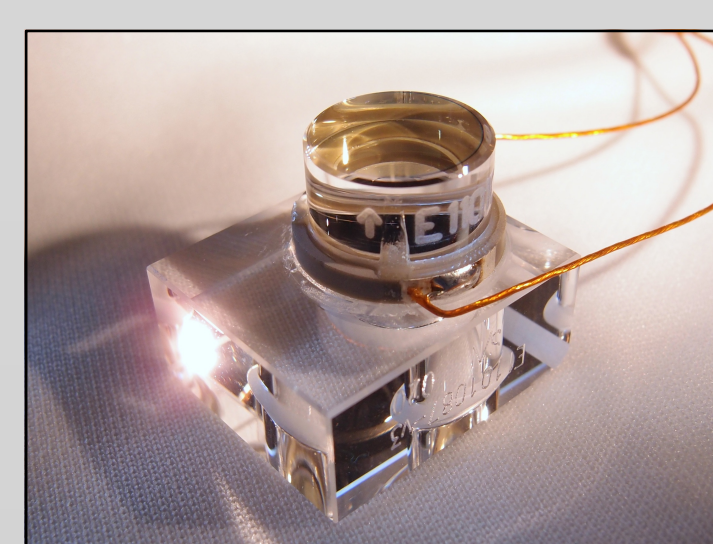

▲ Glued sub-assy

### Baking

- Baking for epoxy curing and de-outgassing: After the breadboard bonding, the OMC on the transport fixture was vacuum-baked for 48hours. The bake temp. of 80degC was determined not to exceed the glass transition temperature of the epoxies.

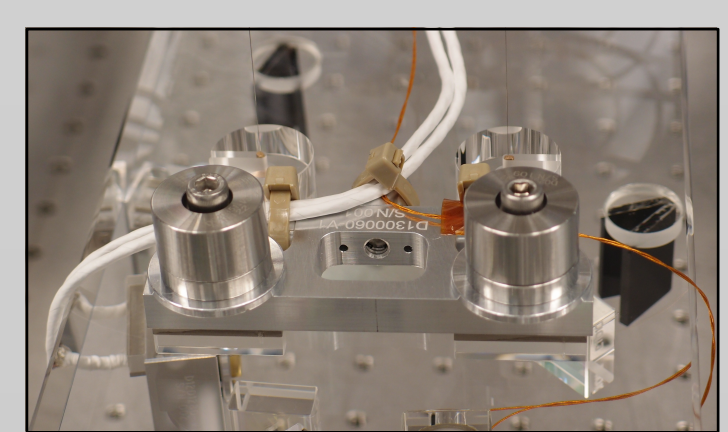

▲ Cable stay (top side)

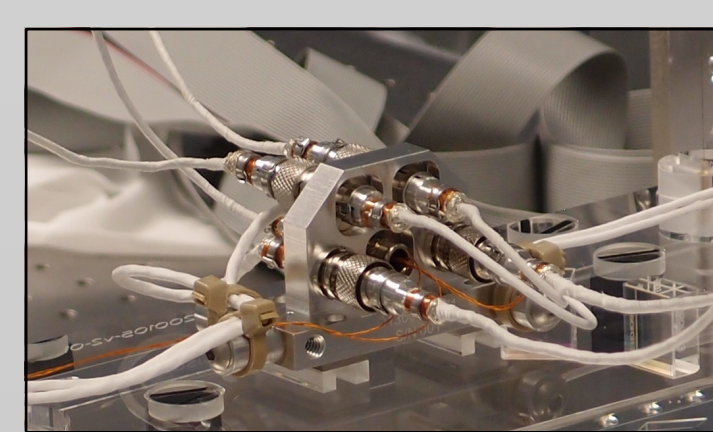

▲ Cable harness (top side)

### Breadboard gluing

- Bonding: Low viscous UV-cure epoxy (EMI OPTOCAST 3553-LV UTF-HM) was used for all of glass-glass joints, otherwise EP30 was used. UVA light was provided from a fiber coupled UV light source (LESCO Super Spot MK III).
- Fixtures: The breadboard was held with a transport fixture. The objects to be glued were aligned along with gluing templates.
- Cavity mirrors: Glued while the cavity parameters were monitored with the optical test setup. The position and alignment of the two curved mirrors can be adjusted by micrometers on the template.

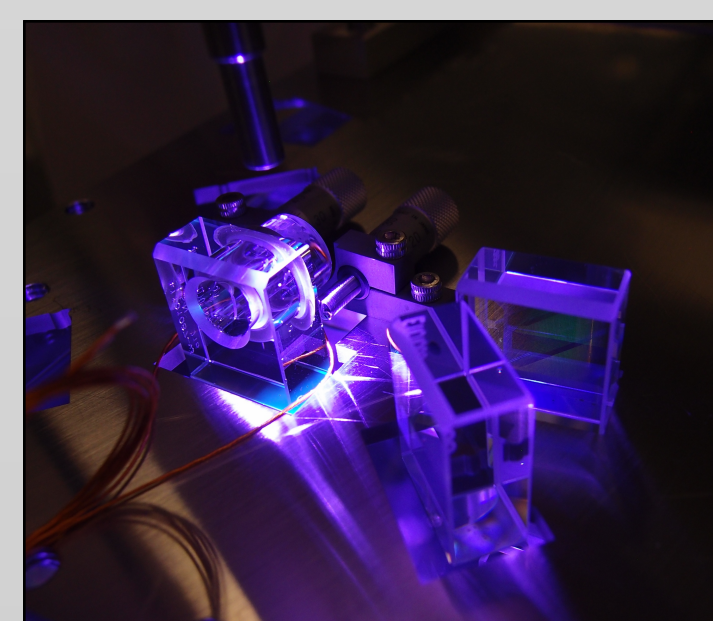

▲ UV illumination

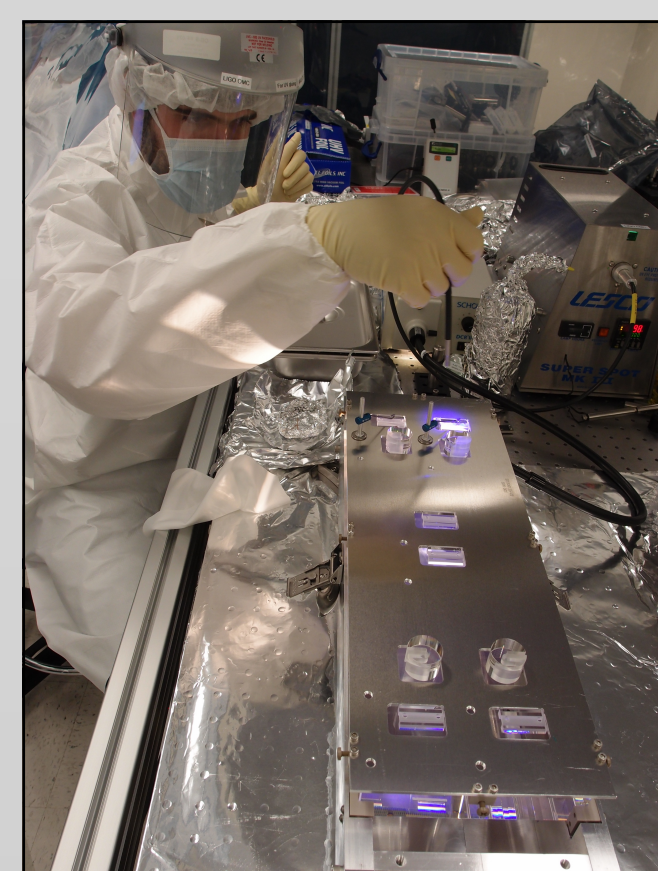

▲ Top-side gluing

### Electrical wiring

- PZT, DCPD, QPD cables:  
All of the cables are routed from the cavity side to a cable harness via cable stays.

GORE's high flex cables (GSC-02-26942-00 & GSC-02-26962-00) are employed except for the UHV compatible wires on the PZTs.

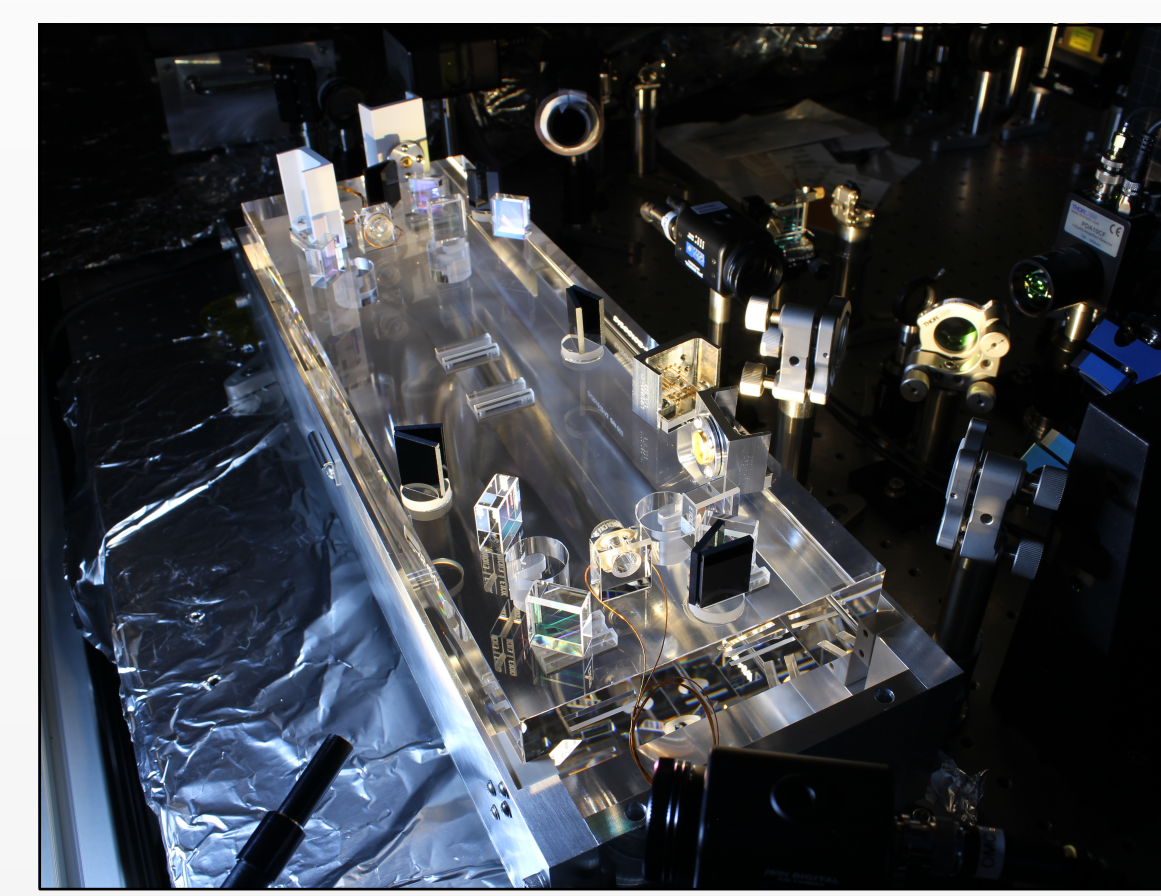

▲ OMC breadboard in the transport fixture

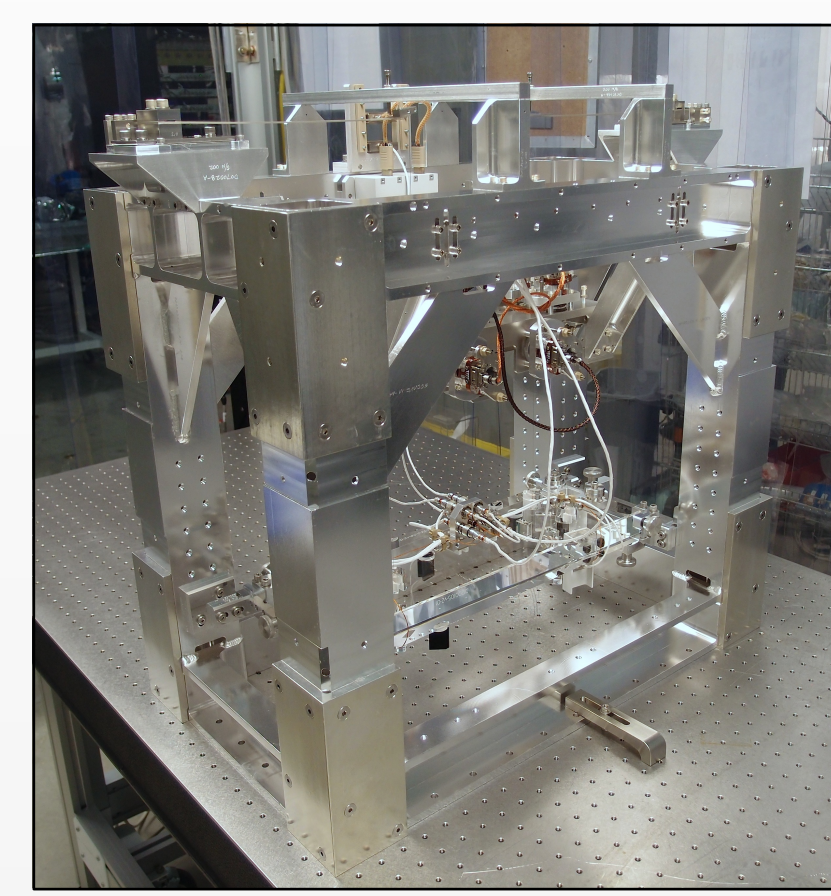

▲ OMC loaded on the suspension

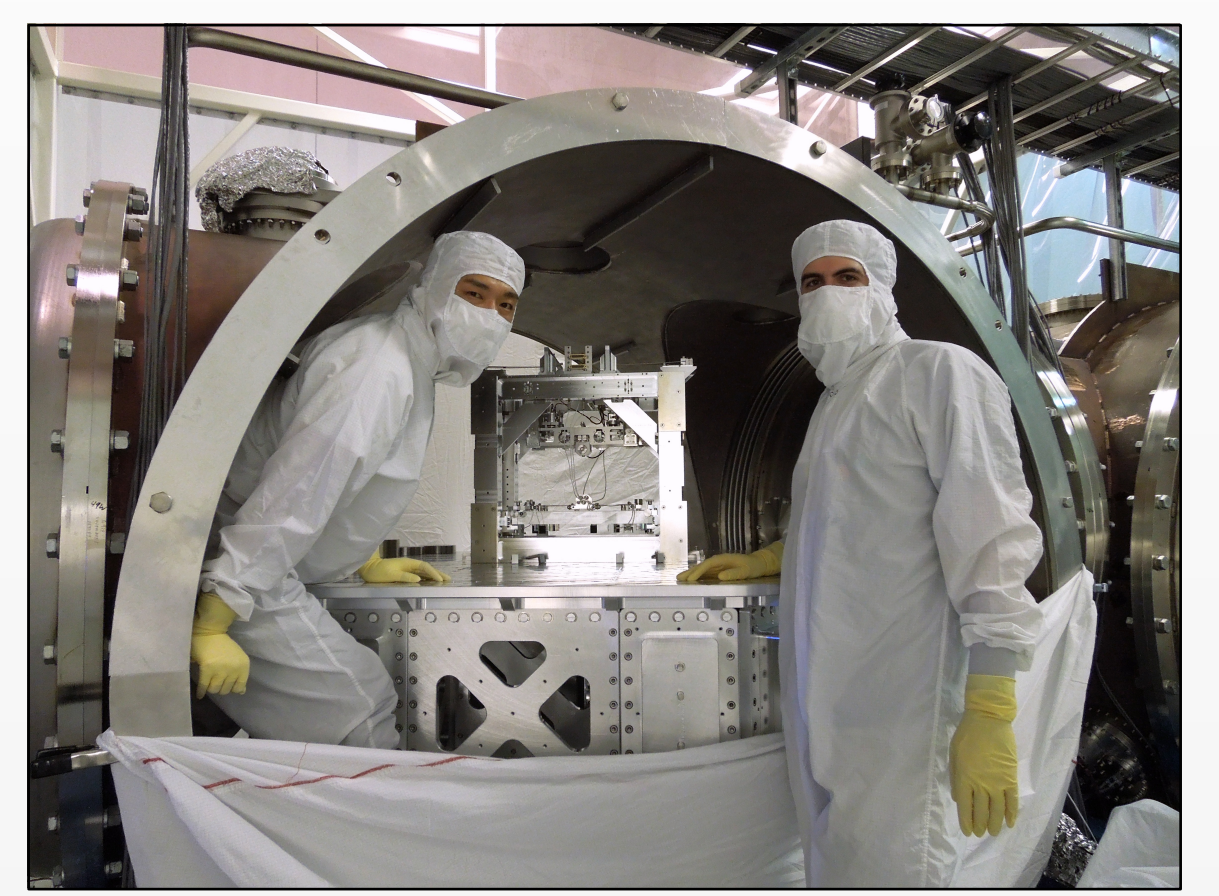

▲ OMC installation on the HAM6 ISI table

## Optical Testing at Caltech

### Optical characterization of the OMC cavity

- A table-top optical setup was built for locking the cavity  
=> Used not only for the characterization after the baking, but also for the fine parameter adjustment during the gluing
- The power budget and the PZT responses were measured
- A broadband EOM and a fast RF photodiode at the transmission to measure the free spectral range, finesse, and HOM structure

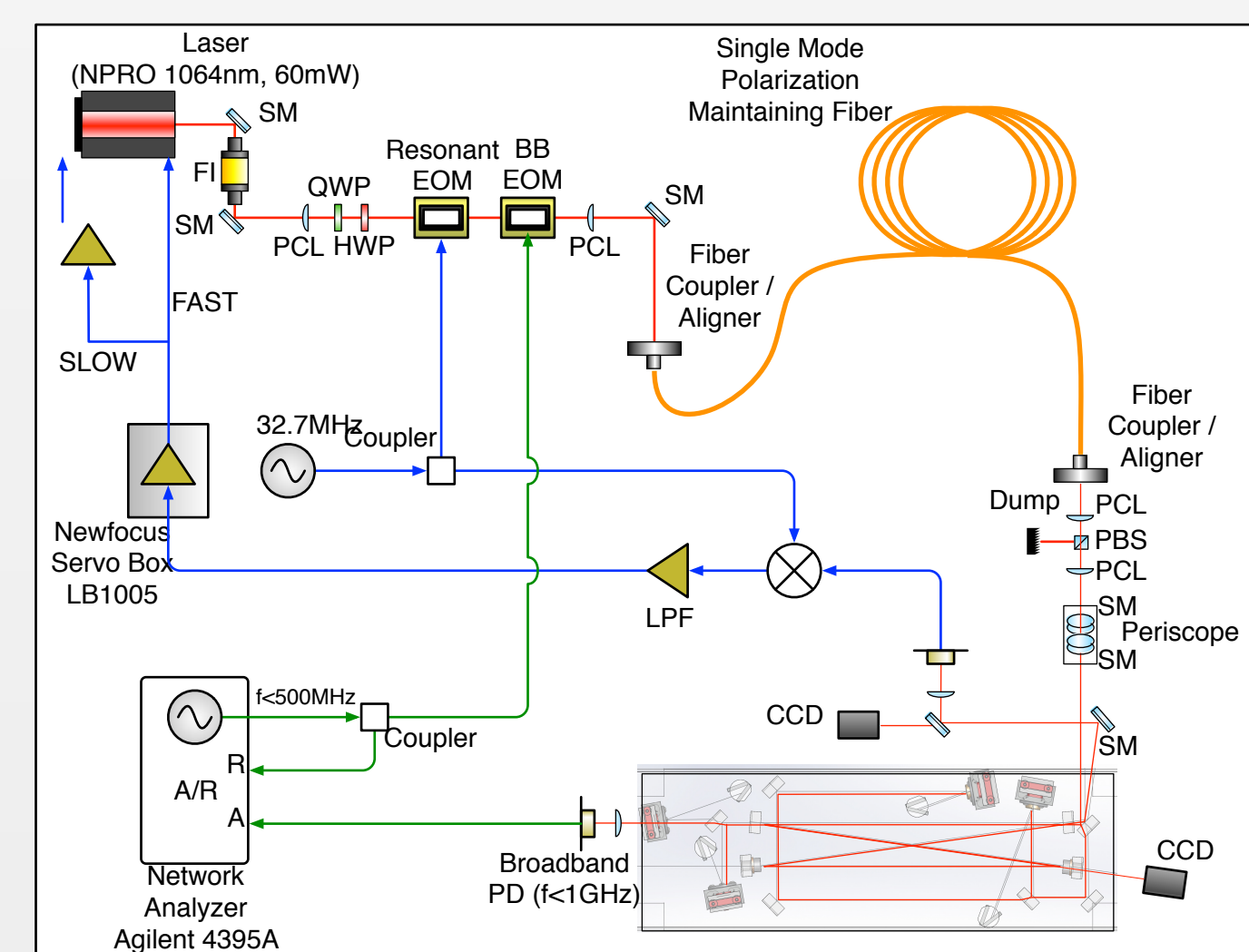

▲ Optical setup for the table top test of the OMC

### Cavity round-trip length

Determined from two measurements:

- 1) FM-AM conversion associated with the locking offset [3]  
An offset in PDH locking induces the FM-AM conversion at around the cavity FSR, but not at the exact FSR. Detect the beat note between the carrier and the AM sidebands at the transmission RF PD.
- 2) AM sideband injection  
AM sidebands are intentionally introduced by rotating the input polarization at the BBEOM. Detect the beat note between the carrier and the AM sidebands at the transmission RF PD. The cavity finesse is also extracted from the measurement result.

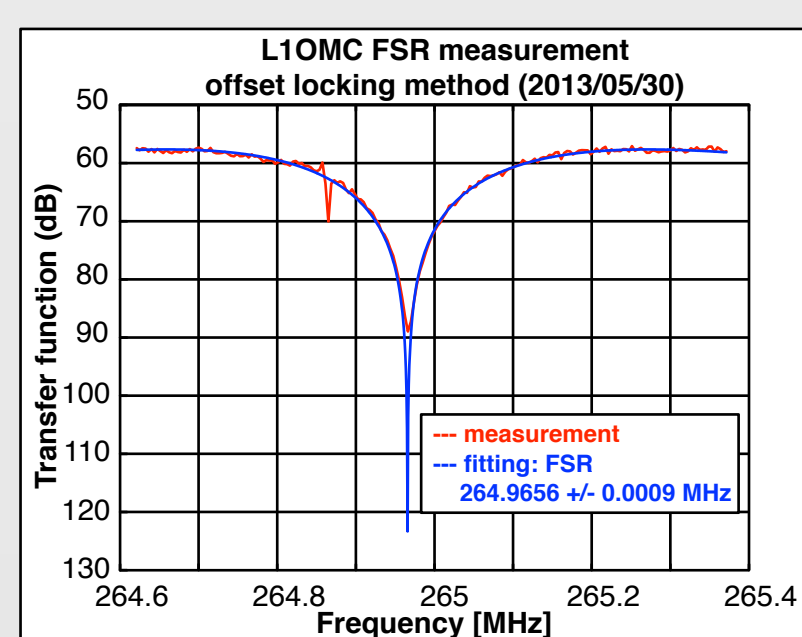

▲ Method1: FSR measurement with FM-AM conversion

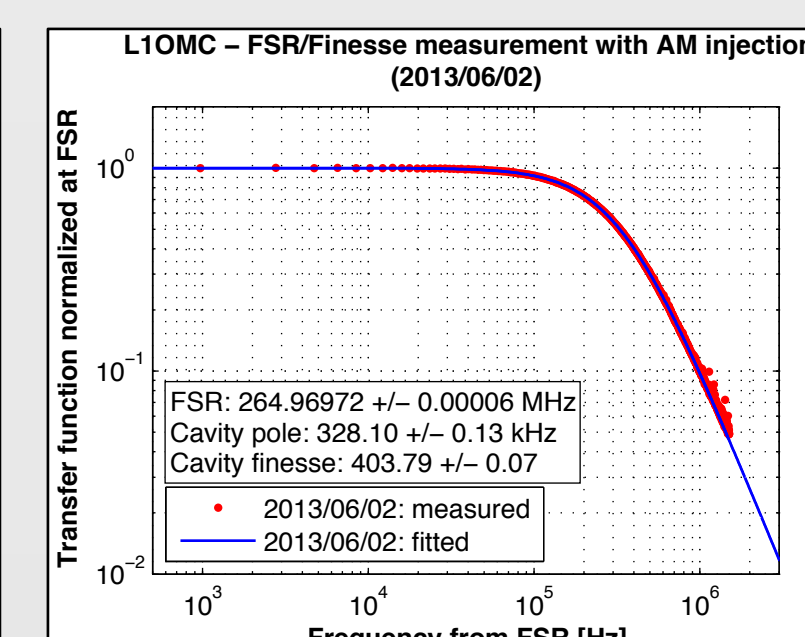

▲ Method2: FSR measurement with AM injection

### Method1 results:

Cavity FSR: 264.9658 +/- 0.0009 MHz

Cavity length: 1.131438 +/- 4x10<sup>-6</sup> m

### Method2 results:

Cavity FSR: 264.96972 +/- 0.00006 MHz

Cavity length: 1.131421 +/- 3x10<sup>-6</sup> m

Cavity finesse: 403.79 +/- 0.07

Spec. 264.8 MHz

1.132 m

390

### Power Budget

Estimated from the input power, transmitted power, visibility, and cavity finesse

	Spec.	Spec.
Mode matching:	99.2 %	N/A
Cavity transmission for TEM <sub>00</sub> :	97.8 %	98.4 %
Cavity reflectivity for TEM <sub>00</sub> :	124 ppm	59.9 ppm
Flat mirror trans. (avg.):	7664 ppm	8300 ppm
Curved mirror trans. (avg.):	42 ppm	50 ppm
Loss per bounce:	22.3 ppm	10 ppm
Loss per roundtrip:	173 ppm	140 ppm

### PZT response

The DC response: checked with free running fringes

The AC response: measured with the cavity locked

PZT1 response@DC: 13.24 +/- 0.02 nm/V (avg) Spec. 15 nm/V

PZT2 response@DC: 12.9 +/- 0.1 nm/V (avg) 15.7 kHz

First resonant freq.: 10 kHz

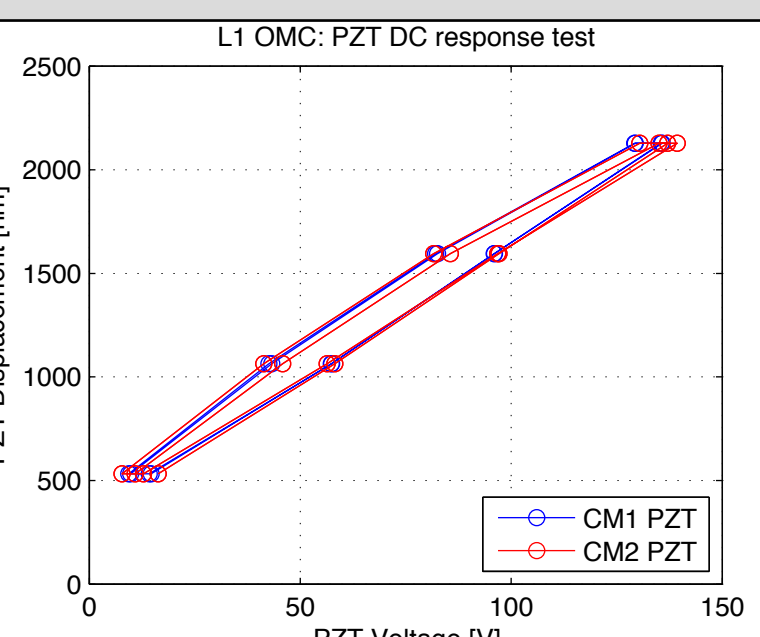

▲ PZT DC scan

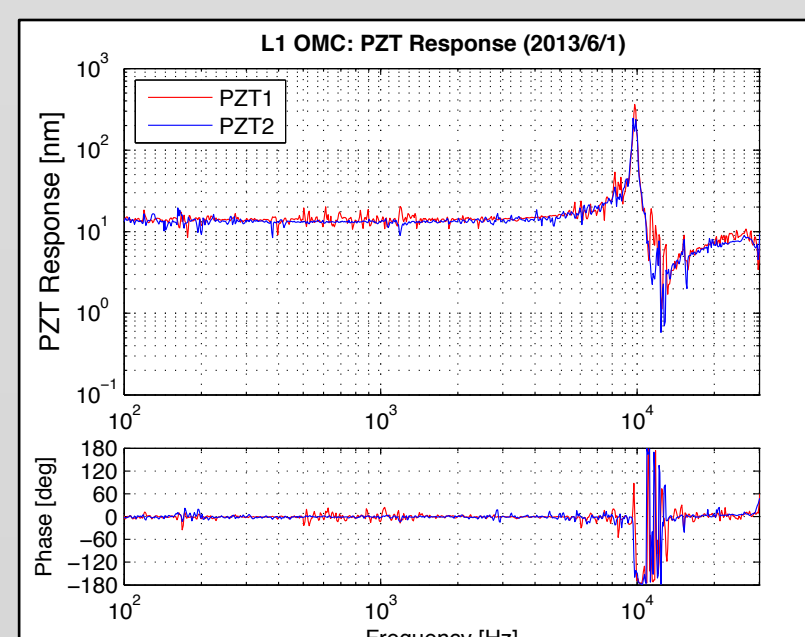

▲ PZT AC response

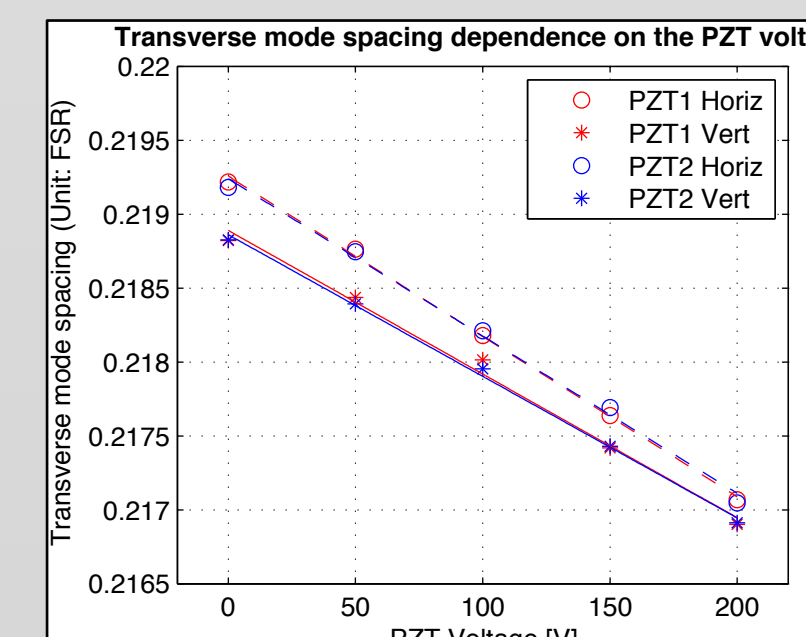

▲ Dependence of the transverse mode spacing on the PZT voltages

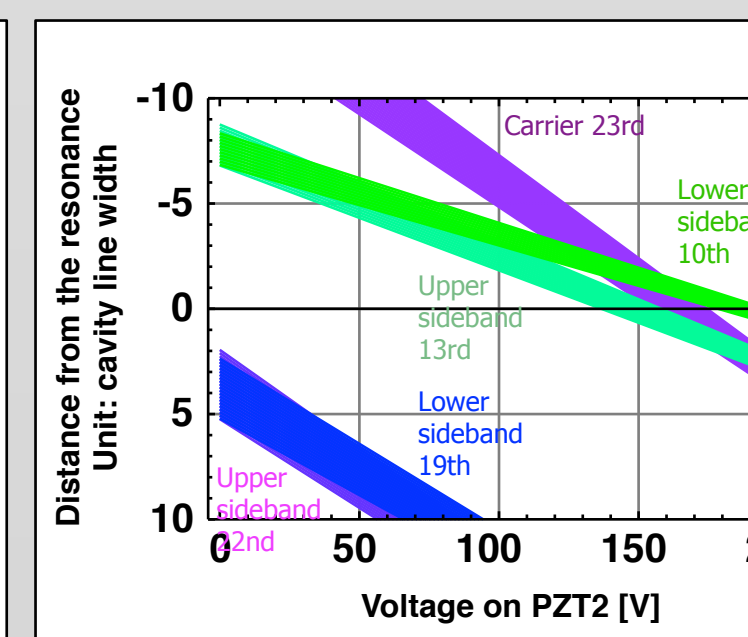

▲ Estimated HOMs coincidence

## Installation at LLO (Jun 2013)

### Integration with the OMC suspension

- OMC Suspension: Prepared at LLO with a metal dummy breadboard
- Breadboard swapping: Unhook and rehook the wires on the wire brackets. (That's it!)
- Cabling: Between the breadboard and the suspension structure
- Weight balance: Adjust the balancing weights
- Suspension tests in LVEA: transfer function measurements, active damping of the six degree of freedom

### OMCS placement on HAM6

- OMCS loading on the ISI: a compact lift truck was employed to hold the OMCS
- Suspension tests in HAM6

## Summary

- aLIGO OMC: Designed based on the eLIGO experience and lessons
- The first OMC was built: The building procedure was established
- Optical testing: Observed the cavity transmission of ~98%  
Confirmed that coincidence of the low order HOMs are successfully avoided.  
Found that the TMS is dependent on the PZT voltages.
- This OMC was installed: **Now in commission at the LLO site!**

[1] K. Arai, S. Barnum, P. Fritschel, J. Lewis, S. Waldman, "Output Mode Cleaner Design", LIGO Document T1000276

[2] K. Arai, "OMC optical design", LIGO Document G1201111

[3] N. Uehara and K. Ueda, "Accurate measurement of the radius of curvature of a concave mirror and the power dependence in a high-finesse Fabry-Perot interferometer", Appl. Opt. 34, pp. 5611-5619 (1995).