

LASER INTERFEROMETER GRAVITATIONAL WAVE OBSERVATORY
- LIGO -
CALIFORNIA INSTITUTE OF TECHNOLOGY
MASSACHUSETTS INSTITUTE OF TECHNOLOGY

Technical Note	LIGO-T1300645-v5	2016/03/07
Re-assessing HAM-ISI Performance Noise Budget Model for aLIGO		
J. S. Kissel		

California Institute of Technology
LIGO Project, MS 18-34
Pasadena, CA 91125
Phone (626) 395-2129
Fax (626) 304-9834
E-mail: info@ligo.caltech.edu

Massachusetts Institute of Technology
LIGO Project, Room NW17-161
Cambridge, MA 02139
Phone (617) 253-4824
Fax (617) 253-7014
E-mail: info@ligo.mit.edu

LIGO Hanford Observatory
Route 10, Mile Marker 2
Richland, WA 99352
Phone (509) 372-8106
Fax (509) 372-8137
E-mail: info@ligo.caltech.edu

LIGO Livingston Observatory
19100 LIGO Lane
Livingston, LA 70754
Phone (225) 686-3100
Fax (225) 686-7189
E-mail: info@ligo.caltech.edu

1 Introduction

With the addition of HEPI, as well as a few extra control paths which are possible from the addition of Stage 0 L4Cs, it is necessary to re-calculate the performance of the platform for noise-budgeting techniques originally developed in eLIGO. This document describes the details of this recalculation.

2 eLIGO Model

Section ?? is an excerpt from Chapter 5 of the author's thesis, P1000103, only slightly updated to follow newer nomenclature and to be more clear. We remind the reader that in eLIGO, the prototype HAM-ISIs were installed into HAM6, whose support stage was "rigidly" secured to the ground, i.e. no external, hydraulic pre-isolation.

The model for the X (and Y) degree of freedom optical table displacement, "Stage 1 (ST1)," or x_{ST1} , of the eLIGO HAM-ISI is shown in Figure ?. Ground motion, x_{gnd} , is suppressed by the transmission of the passive isolation system, called the "plant," P_x . Residual motion of Stage 1 is sensed by the displacement and inertial sensors. The displacement sensor signal measures the relative displacement between both Stage 1 and the support stage, "Stage 0 (ST0)," or x_{ST0} , motion which, in the case of eLIGO, we consider to be equivalent to x_{gnd} . This relative signal is corrected for motion of the support stage / ground by blending in a signal from an inertial sensor signal mounted on the ground, high-passed with a filter set F_{gnd}^{SC} , a technique known as "sensor correction (SC)." The inertial-sensor-corrected displacement sensor signal is then low-passed with F_x^{LP} . The inertial sensor signal is high-passed with a filter F_x^{HP} , complementary to F_x^{LP} . From there, the signals are added to form the super sensor. A final control filter K_x shapes the super sensor signal into a force which is fed back to the actuators, further reducing the motion of the platform.

In addition to ground motion, x_{gnd} , we include several noise sources which we measure or model. For translational degrees of freedom (X and Y), these sources are sensor noise from each of the sensors: the on-board GS13 inertial sensors, n_{GS13} , the displacement sensors n_{CPS} , and ground inertial sensor n_{STS} ; and residual tilt of the platform, ry_{ST1} . We will find that these sensor noises are those limiting the platform performance. Other, non-limiting, noise sources not considered include ground tilt coupling into the ground inertial sensor translation signal, actuator noise, ADC/DAC noise, and non-linear coupling.

The frequency response from the sensors and output from actuators have been compensated and given the appropriate gain to transfer any information in the colocated basis (e.g. sensor noise) into the cartesian basis. The raw sensor noise (Figure ??) for the on-board sensors (CPSs and GS13s) that make up a given signal in the cartesian basis (three per degree of freedom) are assumed to be independent and therefore added in quadrature. The noise for the STS is already in the cartesian basis, and is assumed to be similar for all three degrees of freedom.

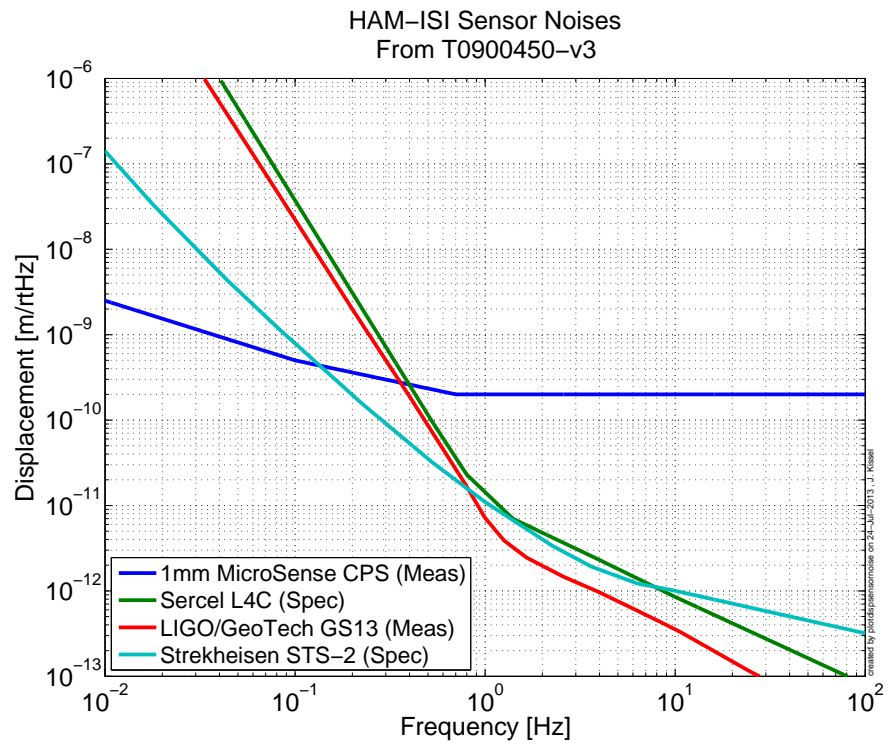

Figure 1: Displacement noise, n , for individual sensors of a given type that are used in, on, and around the HAM-ISI.

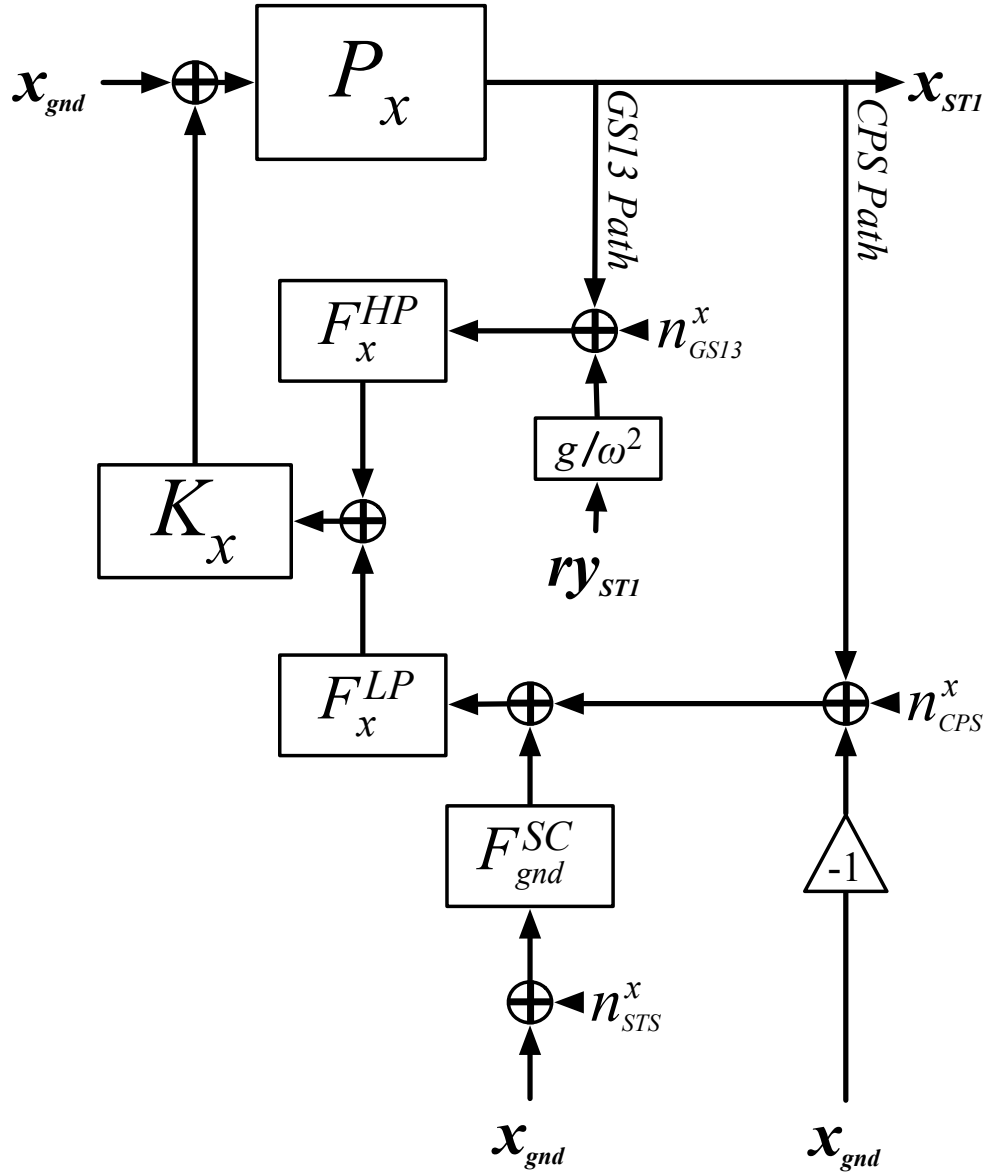

Figure 2: eLIGO Model of active control loop and noise couplings to the platform motion x_{ST1} . The loop shown is for the X translation direction, but where appropriate, noise couplings are treated to be the same for all degrees of freedom. These noise sources are input ground motion, x_{gnd} ; sensor noise from the on-board inertial sensors, n_{GS13}^x , the capacitive displacement sensors n_{CPS}^x , and ground inertial sensor n_{STS}^x ; and platform tilt noise (originating from residual ground motion or sensor noise), ry_{ST1} .

The horizontal platform motion x_{ST1} is determined by working counter-clockwise through the model

$$x_{ST1} = P_x x_{gnd} + P_x K_x \left[\begin{aligned} & F_x^{HP} \left\{ x_{ST1} + n_{GS13}^x + \frac{g}{\omega^2} ry_{ST1} \right\} \\ & + F_x^{LP} \{ x_{ST1} - x_{gnd} + n_{CPS}^x \} \\ & + F_x^{LP} F_{gnd}^{SC} \{ x_{gnd} + n_{STS} \} \end{aligned} \right]. \quad (1)$$

Defining the open loop gain transfer function, G_x , as

$$G_x = P_x K_x (F_x^{HP} + F_x^{LP}) = P_x K_x, \quad (2)$$

where we have used $(F_x^{HP} + F_x^{LP}) = 1$ because they are designed as a complementary pair, then we may solve for the platform motion in terms of the uncorrelated noise source terms,

$$x_{ST1} = \left(\frac{G_x}{1 - G_x} \right) \left(\frac{P_x}{G_x} + F_x^{LP} (F_{gnd}^{SC} - 1) \right) x_{gnd} \\ + \left(\frac{G_x}{1 - G_x} \right) F_x^{HP} \frac{g}{\omega^2} ry_{ST1} \\ + \left(\frac{G_x}{1 - G_x} \right) F_x^{HP} n_{GS13}^x \\ + \left(\frac{G_x}{1 - G_x} \right) F_x^{LP} n_{CPS}^x \\ + \left(\frac{G_x}{1 - G_x} \right) F_x^{LP} F_{gnd}^{SC} n_{STS}. \quad (3)$$

The remaining degrees of freedom are calculated in a similar fashion, but are simpler because they are insensitive to tilt of the platform. The model for vertical motion, z_{ST1} , tilt, $t_{ST1} = rx_{ST1} = ry_{ST1}$, and rotation about the Z axis, rz_{ST1} are,

$$z_{ST1} = \frac{G_z}{1 - G_z} \left(\frac{P_z}{G_z} + F_z^{LP} (F_{gnd}^{SC} - 1) \right) z_{ST0} \\ + \frac{G_z}{(1 - G_z)} F_z^{HP} n_{GS13}^z \\ + \frac{G_z}{(1 - G_z)} F_z^{LP} n_{CPS}^z \\ + \frac{G_z}{(1 - G_z)} F_z^{LP} F_{gnd}^{SC} n_{STS} \quad (4)$$

$$t_{ST1} = \frac{G_t}{(1 - G_t)} \left(\frac{P_t}{G_t} - F_t^{LP} \right) t_{gnd} + \frac{G_t}{(1 - G_t)} F_t^{HP} n_{GS13}^t + \frac{G_t}{(1 - G_t)} F_t^{LP} n_{CPS}^t \quad (5)$$

$$rz_{ST1} = \frac{G_{rz}}{(1 - G_{rz})} \left(\frac{P_{rz}}{G_{rz}} - F_{rz}^{LP} \right) rz_{gnd} + \frac{G_{rz}}{(1 - G_{rz})} F_{rz}^{HP} n_{GS13}^{rz} + \frac{G_{rz}}{(1 - G_{rz})} F_{rz}^{LP} n_{CPS}^{rz} \quad (6)$$

3 aLIGO Model

For the aLIGO HAM-ISIs, there are a few notable differences, as indicated in red in Figure ???. We will focus the model on the SRCL HAM-ISIs (i.e. HAM4 and HAM5) as they will potentially have the most complicated loop structure. To calculate the performance of other platforms such as those in HAMs 2, 3, and 6, one can simply ignore paths which are not used.

There are several clarifications in the notation in which we make the plant notation much more explicit. First, we split the generic plant P_x into the displacement response to displacement $P_x^{(0-1)}$ in [m/m], and the displacement response to force $P_x^{(1-1)}$, in [m/N]. We also explicitly include the damping path, which picks off the GS13s (after sensor and tilt noise is incorporated) and filters them with a limited-band-width control filter, K_x^D . This had not been included in the eLIGO model because it was deemed negligible, but we include it here just incase tilt noise from the GS13s is problematic at very low frequency. In order to make final terms more comparable to original eLIGO terms, we fold in the damping loop gain G_x^D separately from the isolation loop gain G_x^I , where the apostrophe is indicative that the isolation loop gain contains the *damped* plant, $P_x' = P_x/(1 - G_x^D)$.

All aLIGO HAM-ISIs are mounted on HAM-HEPIs, which create a non-negligible transfer function between the ground motion and the support stage of the HAM-ISI. Thus, we now explicitly differentiate between the two noise sources: the support stage – Stage 0 – displacement x_{ST0} , and the ground displacement x_{gnd} . An additional reason to differentiate is that x_{ST0} can be directly measured by either the HEPI L4Cs or the Stage 0 L4Cs, especially the rotation degrees of freedom. The eLIGO performance model suffered from using models the of the ground rotation.

To improve the performance around 10 [Hz], we have added an array of L4Cs on Stage 0. These are used in a feed-forward path, x_{ST0} and n_{L4C}^x are filtered by the feed-forward filter F_{ST0}^{FF} and added directly to the actuators. (Previous version of this document included the Stage 0 L4Cs potentially used in a sensor correction path, with the implicit intent to use it where there is servo loop gain at low-frequency, but given the low-frequency noise of the L4C, it does not make sense to use them as sensor correction, so it has been removed).

Note that we assume here that the ground sensor correction, through F_{GND}^{SC} , will continue to be fed to the HAM-ISI's capacitive position sensors as in eLIGO, instead of the baseline aLIGO plan to sensor correct the HAM-HEPI inductive position sensors as had been done in iLIGO.

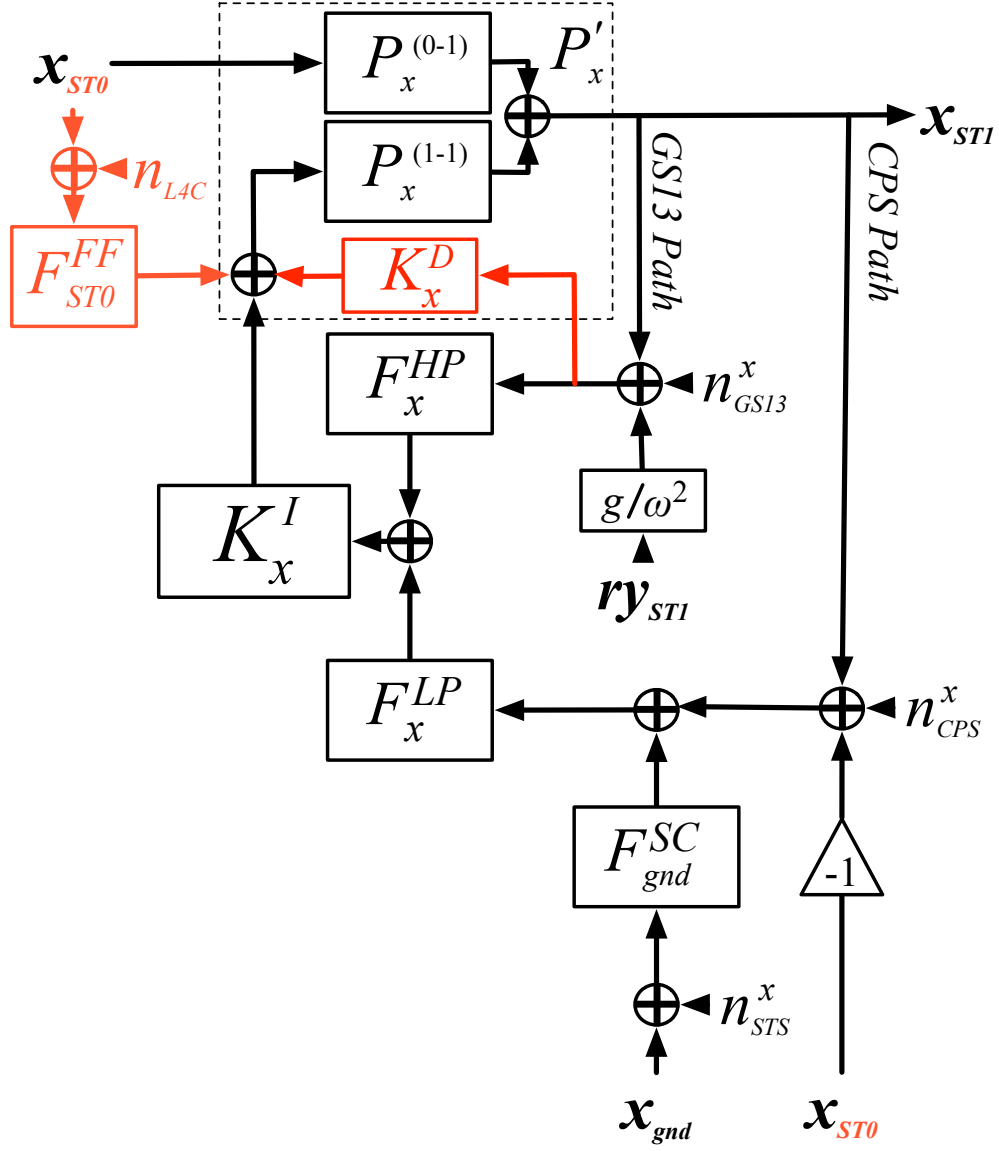

Figure 3: aLIGO Model of active control loop and noise couplings to the platform motion x_{ST1} . The differences between the eLIGO and aLIGO model are highlighted in red. These include highlighting that the input motion from the ground x_{gnd} and the support stage x_{ST0} are non-negligibly different, and the inclusion of feed-forward path using the new in-vacuum L4Cs on the support stage, through F_{ST0}^{FF} .

Under the above aLIGO topology, the horizontal performance becomes

$$\begin{aligned}
x_{ST1} = & P_x^{(0-1)} x_{ST0} + P_x^{(1-1)} \left[F_{ST0}^{FF} (x_{ST0} + n_{LAC}^x) \right. \\
& + K_x^D \left(x_{ST1} + n_{GS13}^x + \frac{g}{\omega^2} r y_{ST1} \right) \\
& + K_x^I \left(\begin{aligned} & F_x^{HP} \{ x_{ST1} + n_{GS13}^x + \frac{g}{\omega^2} r y_{ST1} \} \\ & + F_x^{LP} \{ x_{ST1} - x_{ST0} + n_{CPS} \} \\ & + F_x^{LP} F_{gnd}^{SC} \{ x_{GND} + n_{STS}^x \} \end{aligned} \right) \left. \right] \quad (7)
\end{aligned}$$

which we have to re-arrange a little bit differently and more explicitly now that we're including the damping loops. We'll pull out the damping feedback loop gain, so that we can think about the model in the same way as before. Also, because some of us like to design slightly non-complementary blend filters, we keep $F_x^{HP} + F_x^{LP}$ explicitly as ε .

$$\begin{aligned}
(1 - P_x^{(1-1)} K_D) x_{ST1} = & P_x^{(1-1)} K_x^I (F_x^{HP} + F_x^{LP}) x_{ST1} \\
& + P_x^{(0-1)} x_{ST0} + P_x^{(1-1)} F_{ST0}^{FF} x_{ST0} - P_x^{(1-1)} K_x^I F_x^{LP} x_{ST0} \\
& + P_x^{(1-1)} K_x^I F_x^{LP} F_{gnd}^{SC} x_{gnd} \\
& + P_x^{(1-1)} (K_x^D + K_x^I F_x^{HP}) \frac{g}{\omega^2} r y_{ST1} \\
& + P_x^{(1-1)} (K_x^D + K_x^I F_x^{HP}) n_{GS13}^x \\
& + P_x^{(1-1)} F_{ST0}^{FF} n_{LAC}^x \\
& + P_x^{(1-1)} K_x^I F_x^{LP} n_{CPS}^x \\
& + P_x^{(1-1)} K_x^I F_x^{LP} F_{gnd}^{SC} n_{STS}^x
\end{aligned}$$

$$\text{let } G_x^D = P_x^{(1-1)} K_x^D$$

$$\begin{aligned}
x_{ST1} = & \frac{P_x^{(1-1)}}{1 - G_x^D} K_x^I (F_x^{HP} + F_x^{LP}) x_{ST1} \\
& + \frac{P_x^{(0-1)}}{1 - G_x^D} x_{ST0} + \frac{P_x^{(1-1)}}{1 - G_x^D} F_{ST0}^{FF} x_{ST0} - \frac{P_x^{(1-1)}}{1 - G_x^D} K_x^I F_x^{LP} x_{ST0} \\
& + \frac{P_x^{(1-1)}}{1 - G_x^D} K_x^I F_x^{LP} F_{gnd}^{SC} x_{gnd} \\
& + \frac{P_x^{(1-1)}}{1 - G_x^D} (K_x^D + K_x^I F_x^{HP}) \frac{g}{\omega^2} ry_{ST1} \\
& + \frac{P_x^{(1-1)}}{1 - G_x^D} (K_x^D + K_x^I F_x^{HP}) n_{GS13}^x \\
& + \frac{P_x^{(1-1)}}{1 - G_x^D} F_{ST0}^{FF} n_{LAC}^x \\
& + \frac{P_x^{(1-1)}}{1 - G_x^D} K_x^I F_x^{LP} n_{CPS}^x \\
& + \frac{P_x^{(1-1)}}{1 - G_x^D} K_x^I F_x^{LP} F_{gnd}^{SC} n_{STS}^x \\
\text{let } & \left\{ \begin{array}{l} \frac{P_x^{(1-1)}}{1 - G_x^D} = P_x'^{(1-1)} \text{ (i.e. the damped plant)} \\ \frac{P_x^{(0-1)}}{1 - G_x^D} = P_x'^{(0-1)} \\ (F_x^{HP} + F_x^{LP}) = \varepsilon \end{array} \right.
\end{aligned}$$

$$\begin{aligned}
 x_{ST1} = & P_x'^{(1-1)} K_x^I \varepsilon x_{ST1} \\
 & + P_x'^{(0-1)} x_{ST0} + P_x'^{(1-1)} F_{ST0}^{FF} x_{ST0} - P_x'^{(1-1)} K_x^I F_x^{LP} x_{ST0} \\
 & + P_x'^{(1-1)} K_x^I F_x^{LP} F_{gnd}^{SC} x_{gnd} \\
 & + P_x'^{(1-1)} (K_x^D + K_x^I F_x^{HP}) \frac{g}{\omega^2} ry_{ST1} \\
 & + P_x'^{(1-1)} (K_x^D + K_x^I F_x^{HP}) n_{GS13}^x \\
 & + P_x'^{(1-1)} F_{ST0}^{FF} n_{LAC}^x \\
 & + P_x'^{(1-1)} K_x^I F_x^{LP} n_{CPS}^x \\
 & + P_x'^{(1-1)} K_x^I F_x^{LP} F_{gnd}^{SC} n_{STS}^x
 \end{aligned}$$

$$\text{let } P_x'^{(1-1)} K_x^I = G_x^I$$

$$\begin{aligned}
 (1 - \varepsilon G_x^I) x_{ST1} = & P_x'^{(0-1)} x_{ST0} + P_x'^{(1-1)} F_{ST0}^{FF} x_{ST0} - G_x^I F_x^{LP} x_{ST0} \\
 & + P_x'^{(1-1)} K_x^I F_x^{LP} F_{gnd}^{SC} x_{gnd} \\
 & + P_x'^{(1-1)} (K_x^D + K_x^I F_x^{HP}) \frac{g}{\omega^2} ry_{ST1} \\
 & + P_x'^{(1-1)} (K_x^D + K_x^I F_x^{HP}) n_{GS13}^x \\
 & + P_x'^{(1-1)} F_{ST0}^{FF} n_{LAC}^x \\
 & + P_x'^{(1-1)} K_x^I F_x^{LP} n_{CPS}^x \\
 & + P_x'^{(1-1)} K_x^I F_x^{LP} F_{gnd}^{SC} n_{STS}^x
 \end{aligned}$$

and after similar re-arrangement of terms, solving for the performance,

$$\begin{aligned}
 x_{ST1} = & \frac{P_x'^{(0-1)}}{(1 - \varepsilon G_x^I)} x_{ST0} + \frac{P_x'^{(1-1)}}{(1 - \varepsilon G_x^I)} F_{ST0}^{FF} x_{ST0} - \frac{G_x^I}{(1 - \varepsilon G_x^I)} F_x^{LP} (x_{ST0} - F_{gnd}^{SC} x_{gnd}) \\
 & + \left[\frac{P_x'^{(1-1)} K_x^D}{(1 - \varepsilon G_x^I)} + \frac{G_x^I}{(1 - \varepsilon G_x^I)} F_x^{HP} \right] \frac{g}{\omega^2} ry_{ST1} \\
 & + \left[\frac{P_x'^{(1-1)} K_x^D}{(1 - \varepsilon G_x^I)} + \frac{G_x^I}{(1 - \varepsilon G_x^I)} F_x^{HP} \right] n_{GS13}^x \\
 & + \frac{P_x'^{(1-1)}}{(1 - \varepsilon G_x^I)} F_{ST0}^{FF} n_{LAC}^x \\
 & + \frac{G_x^I}{(1 - \varepsilon G_x^I)} F_x^{LP} n_{CPS}^x \\
 & + \frac{G_x^I}{(1 - \varepsilon G_x^I)} F_x^{LP} F_{gnd}^{SC} n_{STS}^x
 \end{aligned}$$

which comfortably, reduces to Eq. ?? if all new terms are removed (i.e. $x_{ST0} = x_{gnd}$, $F_{ST0}^{FF} = 0$, $P_x'^{(1-1)} K_x^D / (1 - \varepsilon G_x^I) \ll 1$, and $\varepsilon = 1$), and we (incorrectly) treat the damped plant as having the same input for displacement as force $P_x'^{(0-1)} = P_x'^{(1-1)} = P_x$.

As before, the remaining degrees of freedom are calculated in the same fashion. Interestingly,

because the aLIGO HAM-ISIs have information the rotational input motion of the support stage, the performance model can include feed-forward or sensor correction for these degrees of freedom.

$$\begin{aligned}
z_{ST1} = & \frac{P_z'^{(0-1)}}{(1 - \varepsilon G_z'^I)} z_{ST0} + \frac{P_z'^{(1-1)}}{(1 - \varepsilon G_z'^I)} F_{ST0}^{FF} z_{ST0} - \frac{G_z'^I}{(1 - \varepsilon G_z'^I)} F_z^{LP} (z_{ST0} - F_{gnd}^{SC} z_{gnd}) \\
& + \left[\frac{P_z'^{(1-1)} K_z^D}{(1 - \varepsilon G_z'^I)} + \frac{G_z'^I}{(1 - \varepsilon G_z'^I)} F_x^{HP} \right] n_{GS13}^z \\
& + \frac{P_z'^{(1-1)}}{(1 - \varepsilon G_z'^I)} F_{ST0}^{FF} n_{LAC}^z \\
& + \frac{G_z'^I}{(1 - \varepsilon G_z'^I)} F_z^{LP} n_{CPS}^z \\
& + \frac{G_z'^I}{(1 - \varepsilon G_z'^I)} F_z^{LP} F_{gnd}^{SC} n_{STS}^z
\end{aligned}$$

$$\begin{aligned}
t_{ST1} = & \frac{P_t'^{(0-1)}}{(1 - \varepsilon G_t'^I)} t_{ST0} + \frac{P_t'^{(1-1)}}{(1 - \varepsilon G_t'^I)} F_{ST0}^{FF} t_{ST0} - \frac{G_t'^I}{(1 - \varepsilon G_t'^I)} F_t^{LP} t_{ST0} \\
& + \left[\frac{P_t'^{(1-1)} K_t^D}{(1 - \varepsilon G_t'^I)} + \frac{G_t'^I}{(1 - \varepsilon G_t'^I)} F_x^{HP} \right] n_{GS13}^t \\
& + \frac{P_t'^{(1-1)}}{(1 - \varepsilon G_t'^I)} F_{ST0}^{FF} n_{LAC}^t \\
& + \frac{G_t'^I}{(1 - \varepsilon G_t'^I)} F_t^{LP} n_{CPS}^t
\end{aligned} \tag{9}$$

$$\begin{aligned}
rz_{ST1} = & \frac{P_{rz}'^{(0-1)}}{(1 - \varepsilon G_{rz}'^I)} rz_{ST0} + \frac{P_{rz}'^{(1-1)}}{(1 - \varepsilon G_{rz}'^I)} F_{ST0}^{FF} rz_{ST0} - \frac{G_{rz}'^I}{(1 - \varepsilon G_{rz}'^I)} F_{rz}^{LP} rz_{ST0} \\
& + \left[\frac{P_{rz}'^{(1-1)} K_{rz}^D}{(1 - \varepsilon G_{rz}'^I)} + \frac{G_{rz}'^I}{(1 - \varepsilon G_{rz}'^I)} F_x^{HP} \right] n_{GS13}^{rz} \\
& + \frac{P_{rz}'^{(1-1)}}{(1 - \varepsilon G_{rz}'^I)} F_{ST0}^{FF} n_{LAC}^{rz} \\
& + \frac{G_{rz}'^I}{(1 - \varepsilon G_{rz}'^I)} F_{rz}^{LP} n_{CPS}^{rz}
\end{aligned}$$

4 Conclusion

Though the inclusion of several more loops into the HAM-ISI control topology may seem like noise budgeting the performance is daunting, the new topology results in performance terms which are not terribly different from the eLIGO topology, with new terms that appear rather obviously in comparison.

References

- [1] J. Kissel. “Calibrating and Improving the Sensitivity of the LIGO Detectors.” LIGO-P1000103