



*LIGO Laboratory / LIGO Scientific Collaboration*

LIGO-E1300598-V1

*Advanced LIGO*

12 JUL. 2013

**BSC4-L1 & BSC9-H1, Requirements & Procedure, Cartridge Flight  
& Insertion into BSC Chambers, aLIGO**

Sam Barnum, Calum Torrie, Eduardo Chavez

Distribution of this document:  
LIGO Science Collaboration

This is an internal working note  
of the LIGO Project.

**California Institute of Technology**  
**LIGO Project – MS 18-34**  
**1200 E. California Blvd.**  
**Pasadena, CA 91125**  
Phone (626) 395-2129  
Fax (626) 304-9834  
E-mail: info@ligo.caltech.edu

**Massachusetts Institute of Technology**  
**LIGO Project – NW17-161**  
**175 Albany St**  
**Cambridge, MA 02139**  
Phone (617) 253-4824  
Fax (617) 253-7014  
E-mail: info@ligo.mit.edu

**LIGO Hanford Observatory**  
**P.O. Box 1970**  
**Mail Stop S9-02**  
**Richland, WA 99352**  
Phone (509) 372-8106  
Fax (509) 372-8137

**LIGO Livingston Observatory**  
**P.O. Box 940**  
**Livingston, LA 70754**  
Phone (225) 686-3100  
Fax (225) 686-7189

<http://www.ligo.caltech.edu/>

## **1. Reference Documents**

BSC4-L1 D0900471, BSC9-H1 D0901150, Top Level Chamber Assembly

## **2. Rules about constructing BSC Installation Cartridges:**

1. Items hung from the BSC-ISI that break the following rules will need to be removed, Or the cartridge will needed to be maneuvered such that rules are maintained.
  - a. Items must fit within support tubes. See Clearance Zone On P2
  - b. Items must fit within all 4 Beams on the Test-Stand. Also see P2
2. MAX Cartridge weight without 3PT Lifter is 9,500 lbs. See detailed mass budget *E1000202*.
3. CG of the Cartridge in X and Y, must be in the adjustable range of the lifting bar, or masses will need to be added back on, to balance the cartridge (Keel Mass will be removed). Balance may be achieved with temp mass on sidewalls if needed. (In this case, go below 9,500 lbs/4310 kg, then add back on to achieve XY balance).
4. Listing of items on ISI, ITM, ETM, BS/FM, TMS, that will need to be locked down when the cartridge is moved. And Cartridge Install procedure.

### **Conventions:**

1. Views Labeled TOP are viewed from above looking down
2. Views Labeled Bottom are from bellow looking up.
3. Views Labeled Front are looking forwards from behind, so you see the back of the Cartridge.
4. Views Labeled Left are looking left from right side of the cartridge, so you see the right side.
5. All View Names correspond to the Views used in SolidWorks.
6. X-Y-Z Triad in each figure is relative to *G1000125*.
7. Cranes, and the direction of movement, are referred to by their compass orientation. At LHO: +X=North, +Y=West, LLO: +X=West, +Y=South.

Clearance zone layout for BSC

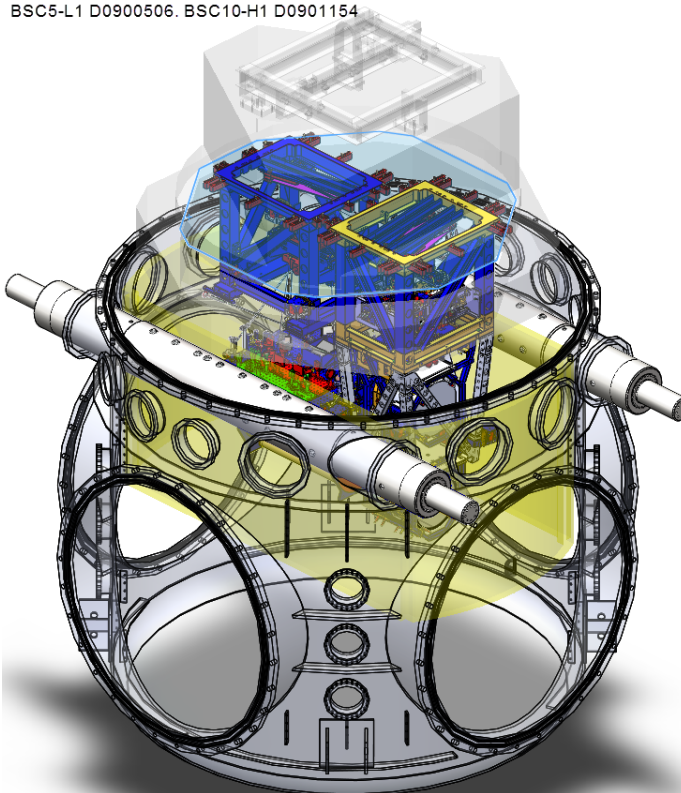
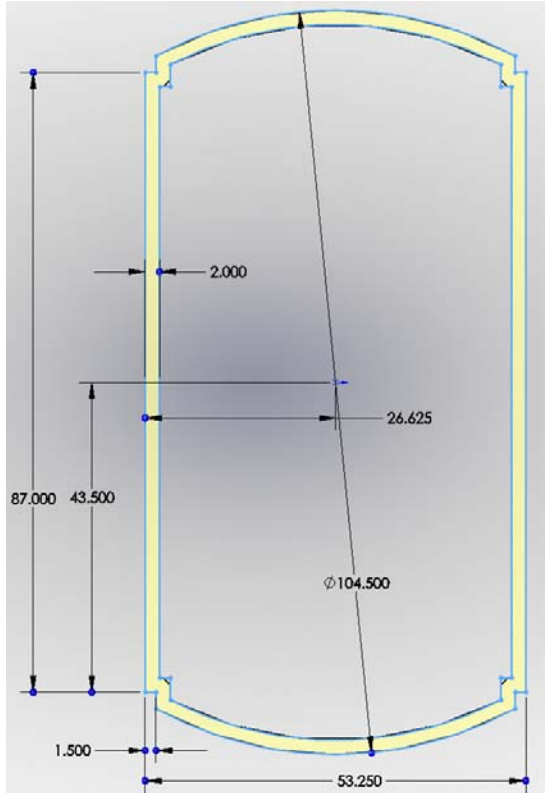

The Clearance Zone is a 2 inch wide area defined between the support tubes, and by the chamber shell. Any items on the cartridge that protrude partly into this zone should be considered for alteration or removal during install. **ANY ITEMS THAT PROTRUDE ALL THE WAY INTO, OR THRU, THE ZONE, MUST EITHER BE REMOVED OR ALTERED SO AS TO STAY CLEAR OF THE ZONE FOR INSTALL.**

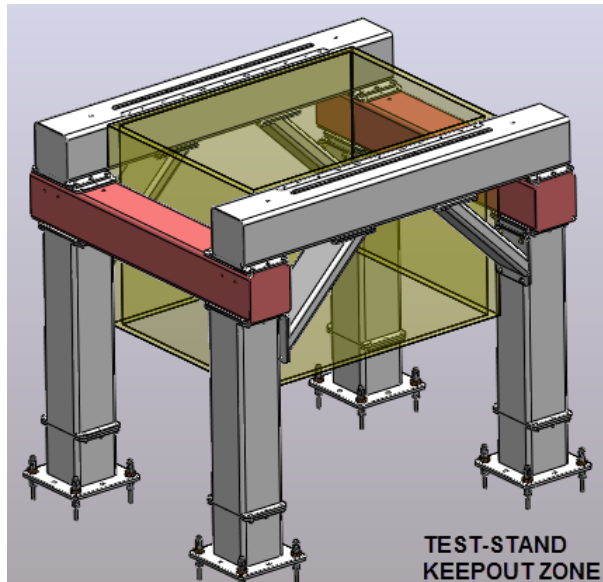
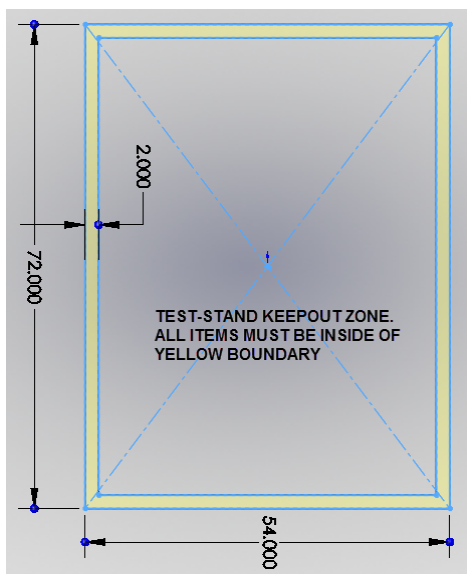

The following pages show the current expected configuration of the BSC cartridge. Any issues with items violating the Clearance Zone are flagged, and possible cartridge maneuvering with the crane during install is suggested. The locations of the CGs is also shown with reference to the lifting bar on top of the cartridge.

Start BSC4-L1 D0900471, BSC9-H1 D0901150, Considerations

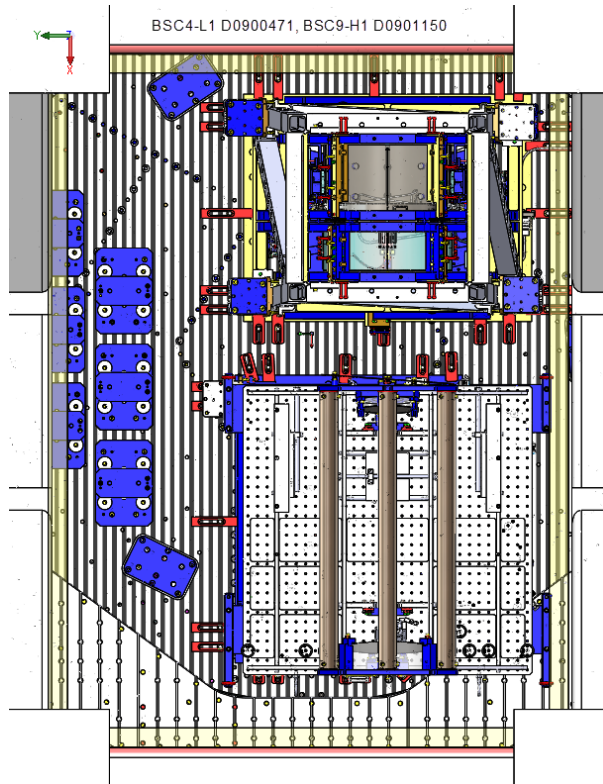
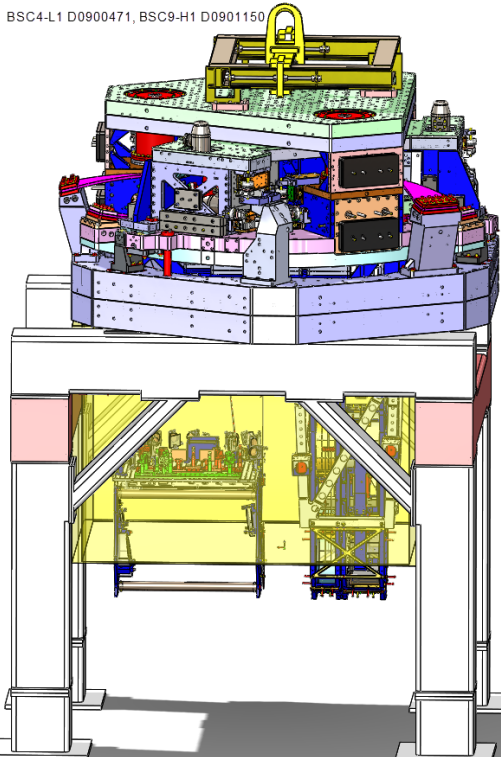
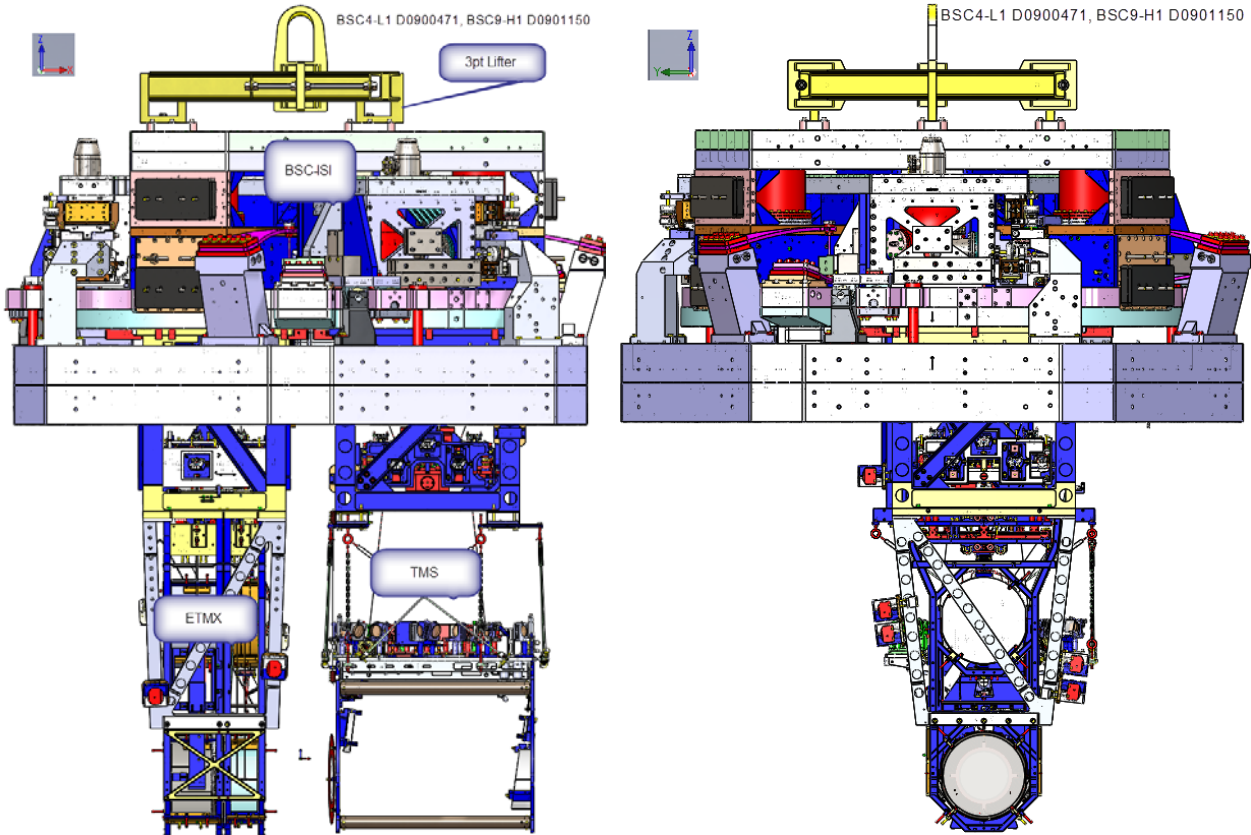

Cartridge will be offset on the Test Stand.

Cartridge installation of BSC. 3pt Lifting bar can cover the range of locations for the XY CG

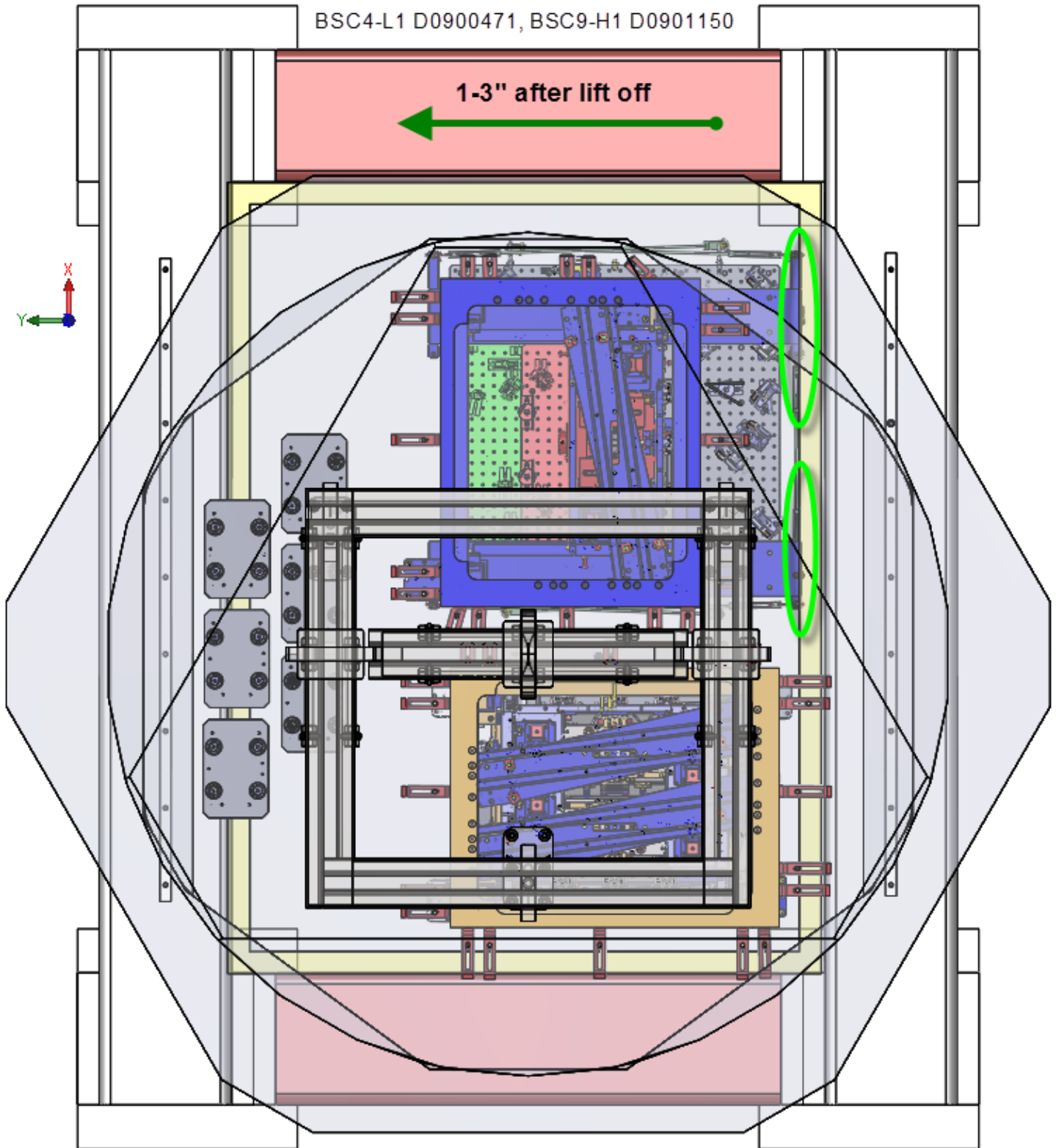

Circles in green indicate any protrusion into the keep out zone. Any global XY moves relative to the Test-Stand will depend on the orientation of the Test-Stand.



BSC4-L1 D0900471, BSC9-H1 D0901150, will not need to be rotated before insertion into the chamber because the test stand is oriented parallel to the support tubes in the BSC chamber.

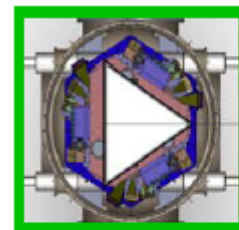
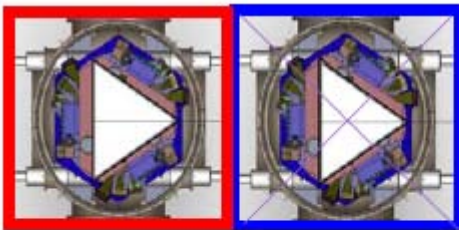
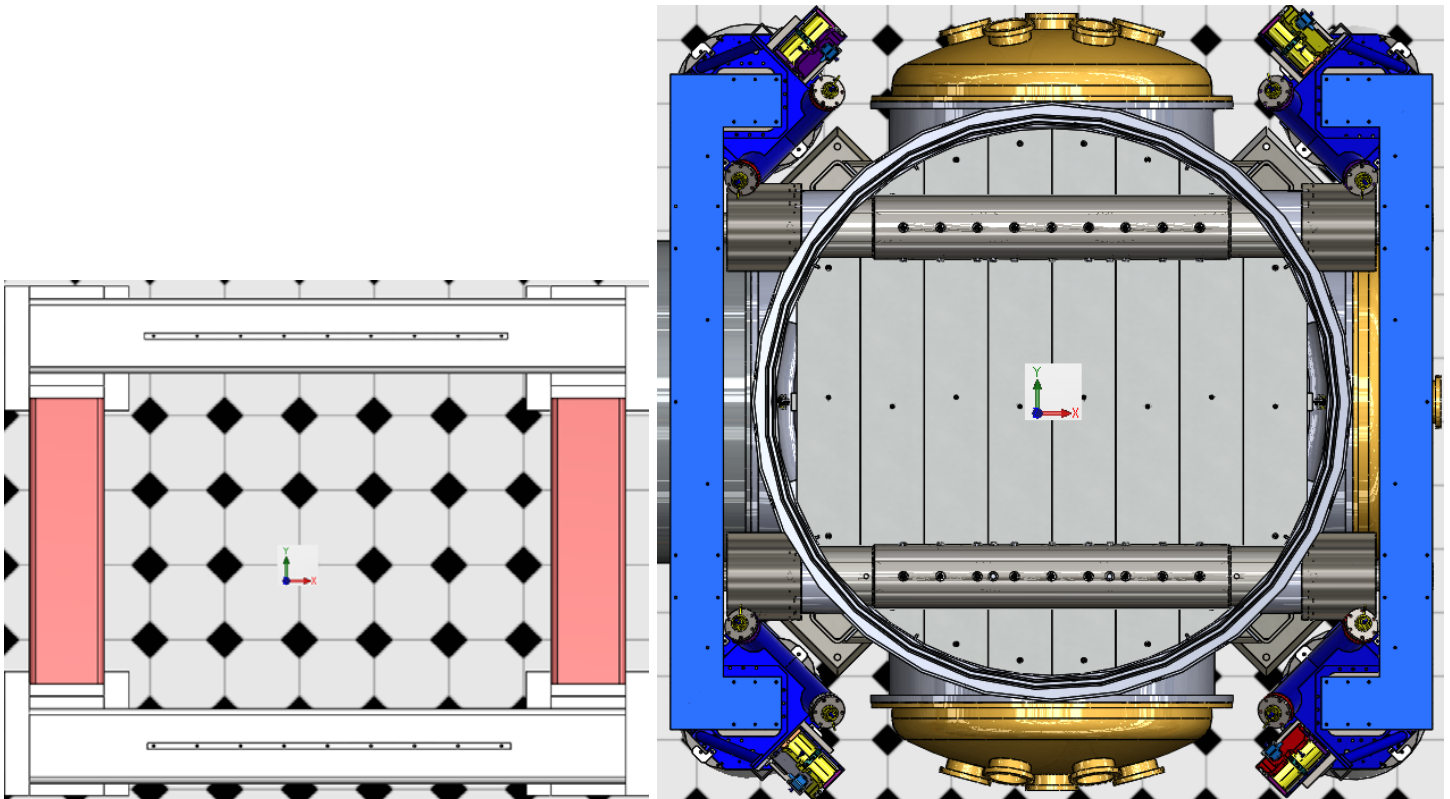

BSC9  
H1:ISI-ETMX  
h1isietmx.mdl  
BSC-ISI/H1/ETMX/

~~BSC5~~  
~~H2:ISI-ETMX~~  
~~h2isietmx.mdl~~  
~~BSC-ISI/H2/ETMX/~~

BSC4  
L1:ISI-ETMX  
l1isietmx.mdl  
BSC-ISI/L1/ETMX/

Orientations are from G1000125

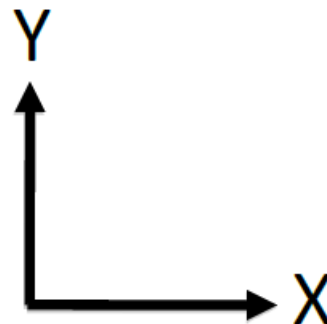

BSC4-L1 D0900471, BSC9-H1 D0901150,, Crane moves need to clear the Chamber Clearance Zone. (NONE)

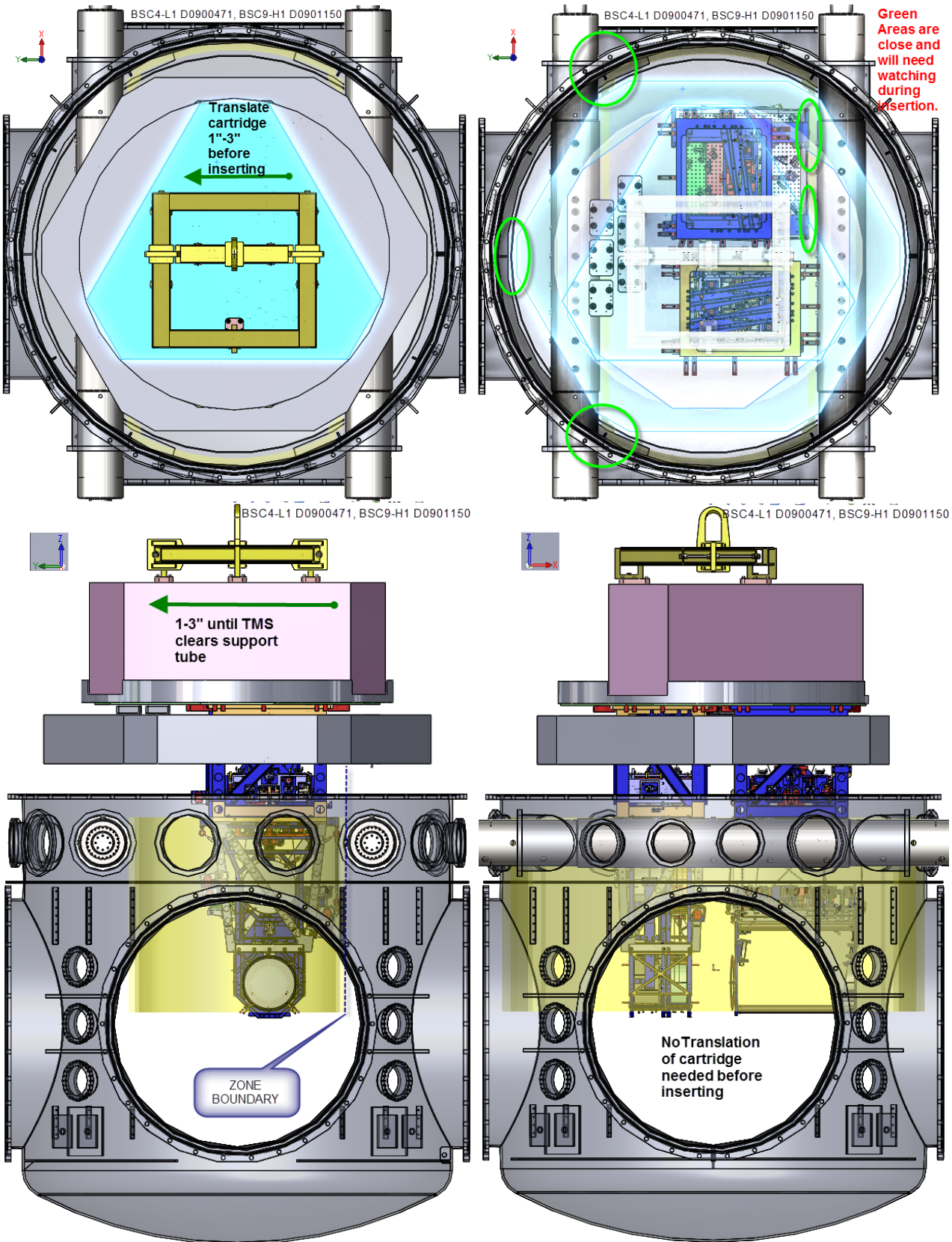

Locating the Bale pre-lift of the cartridge (Some adjustment will be needed)

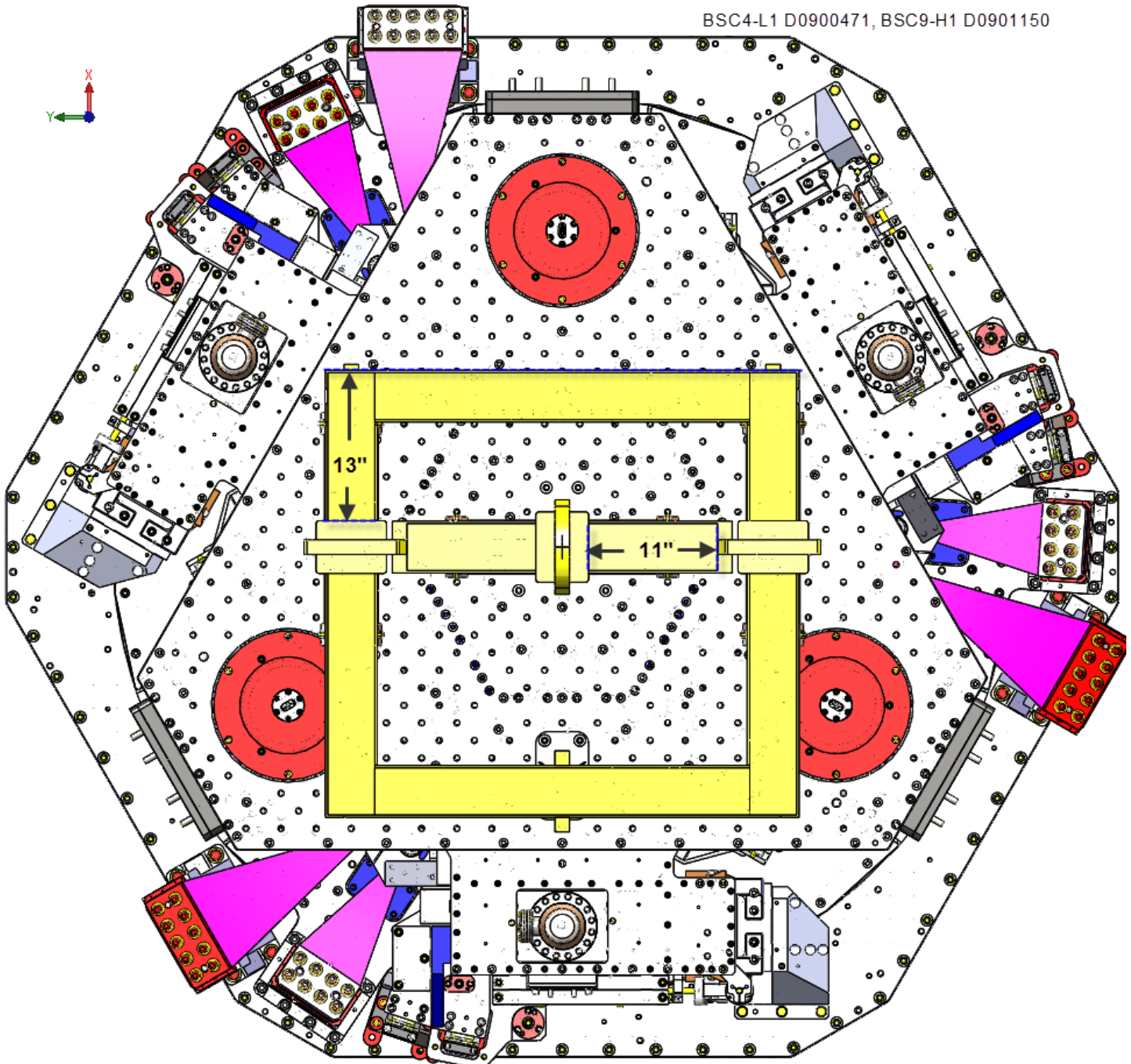



**Items that will need to be locked down when the cartridge is moved:**

1. **BSC-ISI:** (see [E1200344](#) sections 4.2)

<i>completed, approved or checked by:</i> <i>date:</i> <i>comments (optional):</i>
--

2. **ITMY:** Final checks before moving ([T1100406](#)):

<i>completed, approved or checked by:</i> <i>date:</i> <i>comments (optional):</i>
--

**Cartridge: Preparation for, and installation into Chamber:**

aLIGO BSC ISI/Quad Install Procedure: (see [E1200344](#))

<i>completed, approved or checked by:</i> <i>date:</i> <i>comments (optional):</i>
--