



LIGO Laboratory / LIGO Scientific Collaboration

LIGO-E1300597-V1

Advanced LIGO

12 JUL. 2013

**BSC5-L1 & BSC10-H1, Requirements & Procedure, Cartridge
Flight & Insertion into BSC Chambers, aLIGO**

Sam Barnum, Calum Torrie, Eduardo Chavez

Distribution of this document:
LIGO Science Collaboration

This is an internal working note
of the LIGO Project.

California Institute of Technology
LIGO Project – MS 18-34
1200 E. California Blvd.
Pasadena, CA 91125
Phone (626) 395-2129
Fax (626) 304-9834
E-mail: info@ligo.caltech.edu

Massachusetts Institute of Technology
LIGO Project – NW17-161
175 Albany St
Cambridge, MA 02139
Phone (617) 253-4824
Fax (617) 253-7014
E-mail: info@ligo.mit.edu

LIGO Hanford Observatory
P.O. Box 1970
Mail Stop S9-02
Richland, WA 99352
Phone (509) 372-8106
Fax (509) 372-8137

LIGO Livingston Observatory
P.O. Box 940
Livingston, LA 70754
Phone (225) 686-3100
Fax (225) 686-7189

<http://www.ligo.caltech.edu/>

1. Reference Documents

D0900506, D0901154, aLIGO Systems, BSC5-L1 BSC10-H1 Top Level Chamber Assembly

2. Rules about constructing BSC Installation Cartridges:

1. Items hung from the BSC-ISI that break the following rules will need to be removed, Or the cartridge will needed to be maneuvered such that rules are maintained.
 - a. Items must fit within support tubes. See Clearance Zone On P2
 - b. Items must fit within all 4 Beams on the Test-Stand. Also see P2
2. MAX Cartridge weight without 3PT Lifter is 9,500 lbs. See detailed mass budget *E1000202*.
3. CG of the Cartridge in X and Y, must be in the adjustable range of the lifting bar, or masses will need to be added back on, to balance the cartridge (Keel Mass will be removed). Balance may be achieved with temp mass on sidewalls if needed. (In this case, go below 9,500 lbs/4310 kg, then add back on to achieve XY balance).
4. Listing of items on ISI, ITM, ETM, BS/FM, TMS, that will need to be locked down when the cartridge is moved. And Cartridge Install procedure.

Conventions:

1. Views Labeled TOP are viewed from above looking down
2. Views Labeled Bottom are from bellow looking up.
3. Views Labeled Front are looking forwards from behind, so you see the back of the Cartridge.
4. Views Labeled Left are looking left from right side of the cartridge, so you see the right side.
5. All View Names correspond to the Views used in SolidWorks.
6. X-Y-Z Triad in each figure is relative to *G1000125*.
7. Cranes, and the direction of movement, are referred to by their compass orientation. At LHO: +X=North, +Y=West, LLO: +X=West, +Y=South.

Clearance zone layout for BSC

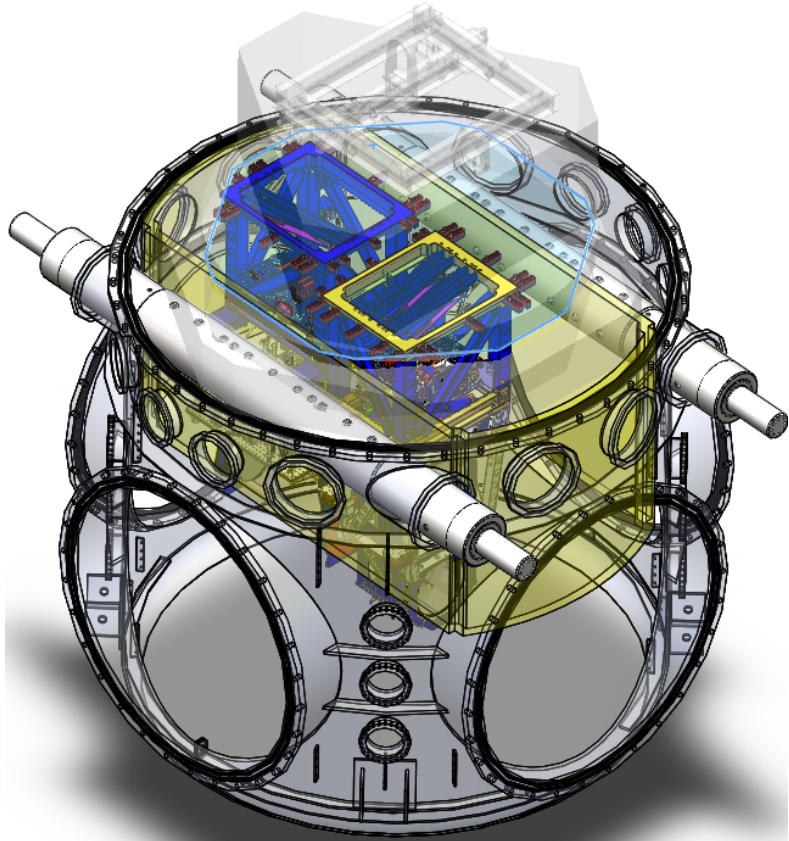
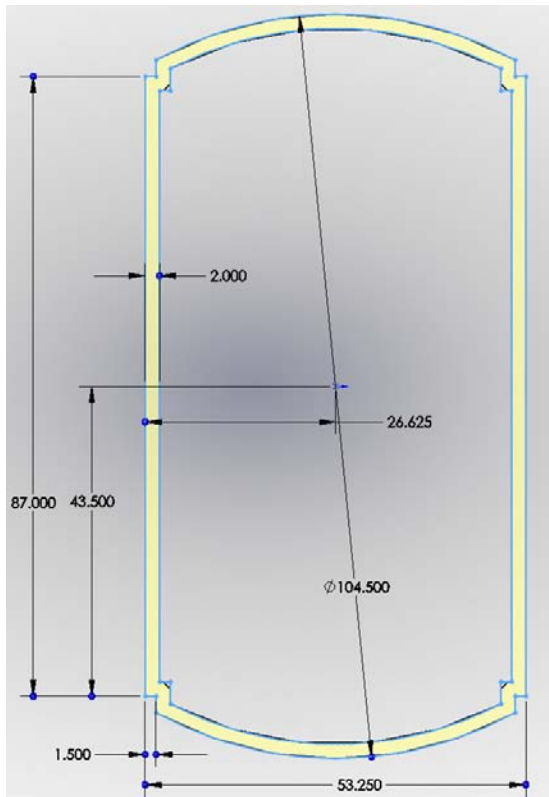

The Clearance Zone is a 2 inch wide area defined between the support tubes, and by the chamber shell. Any items on the cartridge that protrude partly into this zone should be considered for alteration or removal during install. **ANY ITEMS THAT PROTRUDE ALL THE WAY INTO, OR THRU, THE ZONE, MUST EITHER BE REMOVED OR ALTERED SO AS TO STAY CLEAR OF THE ZONE FOR INSTALL.**

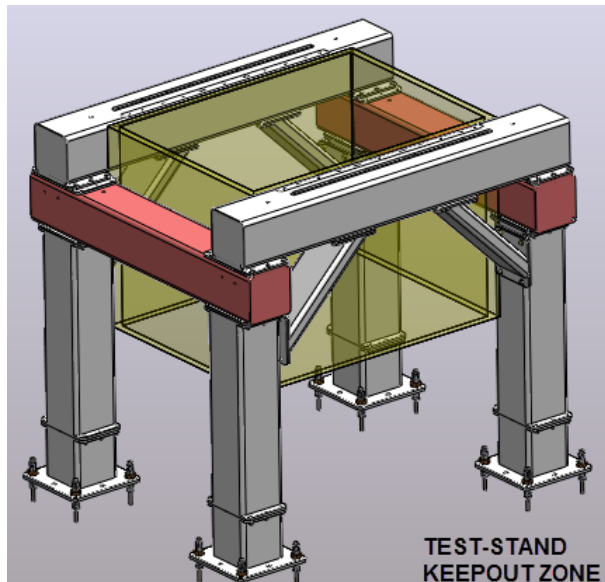
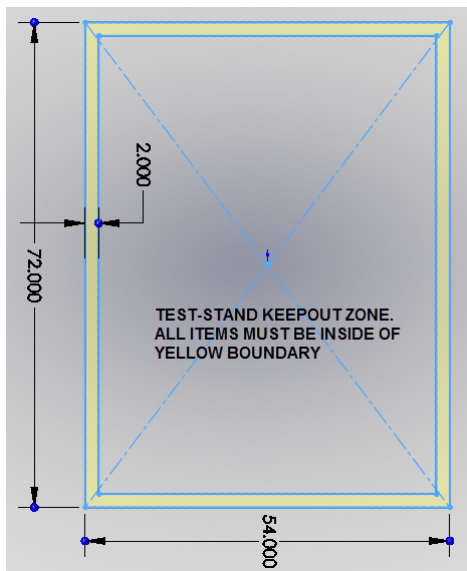

The following pages show the current expected configuration of the BSC5-L1-BSC10-H1 cartridge. Any issues with items violating the Clearance Zone are flagged, and possible cartridge maneuvering with the crane during install is suggested. The locations of the CGs is also shown with reference to the lifting bar on top of the cartridge.

Start BSC5-L1 D0900506, BSC10-H1 D0901154 Considerations

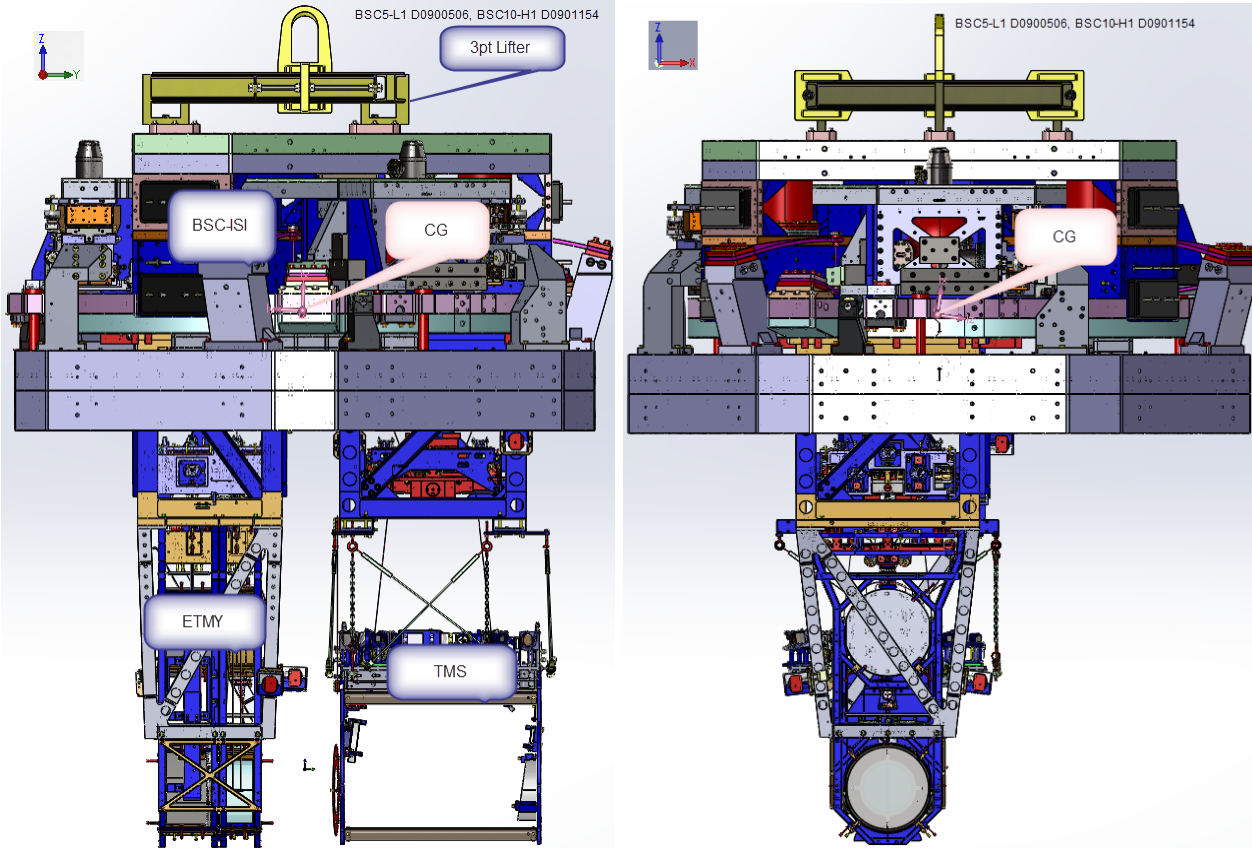

Cartridge installation of BSC. 3pt Lifting bar can cover the range of locations for the XY CG

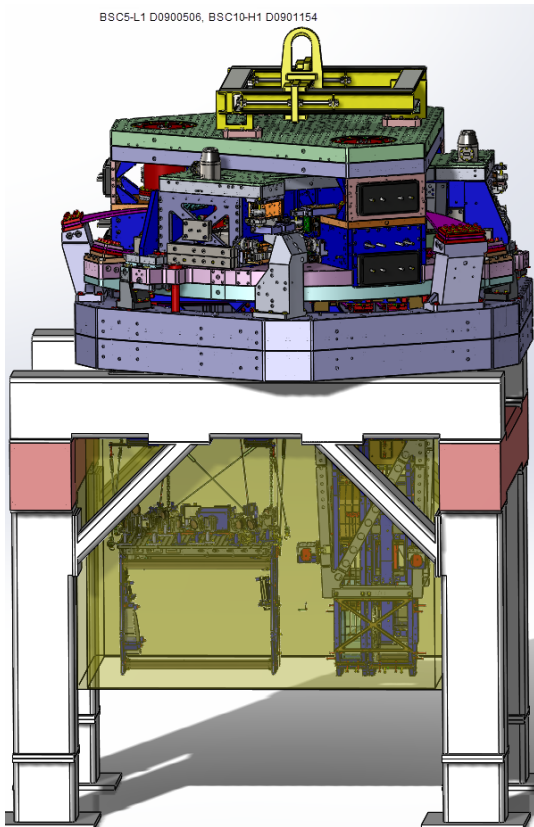

Cartridge will be offset on the Test Stand.

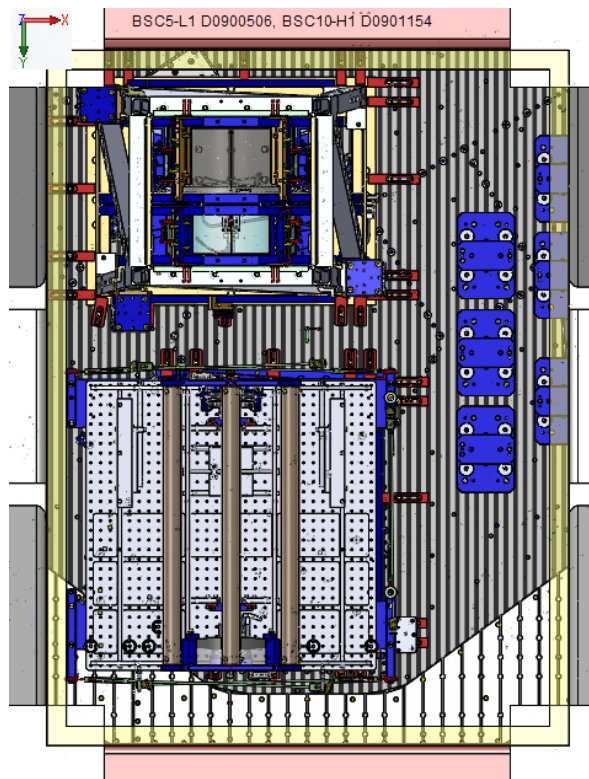

BSC5-L1 D0900506, BSC10-H1 D0901154, Crane moves need to clear the Test Stand Clearance Zone. (NONE)

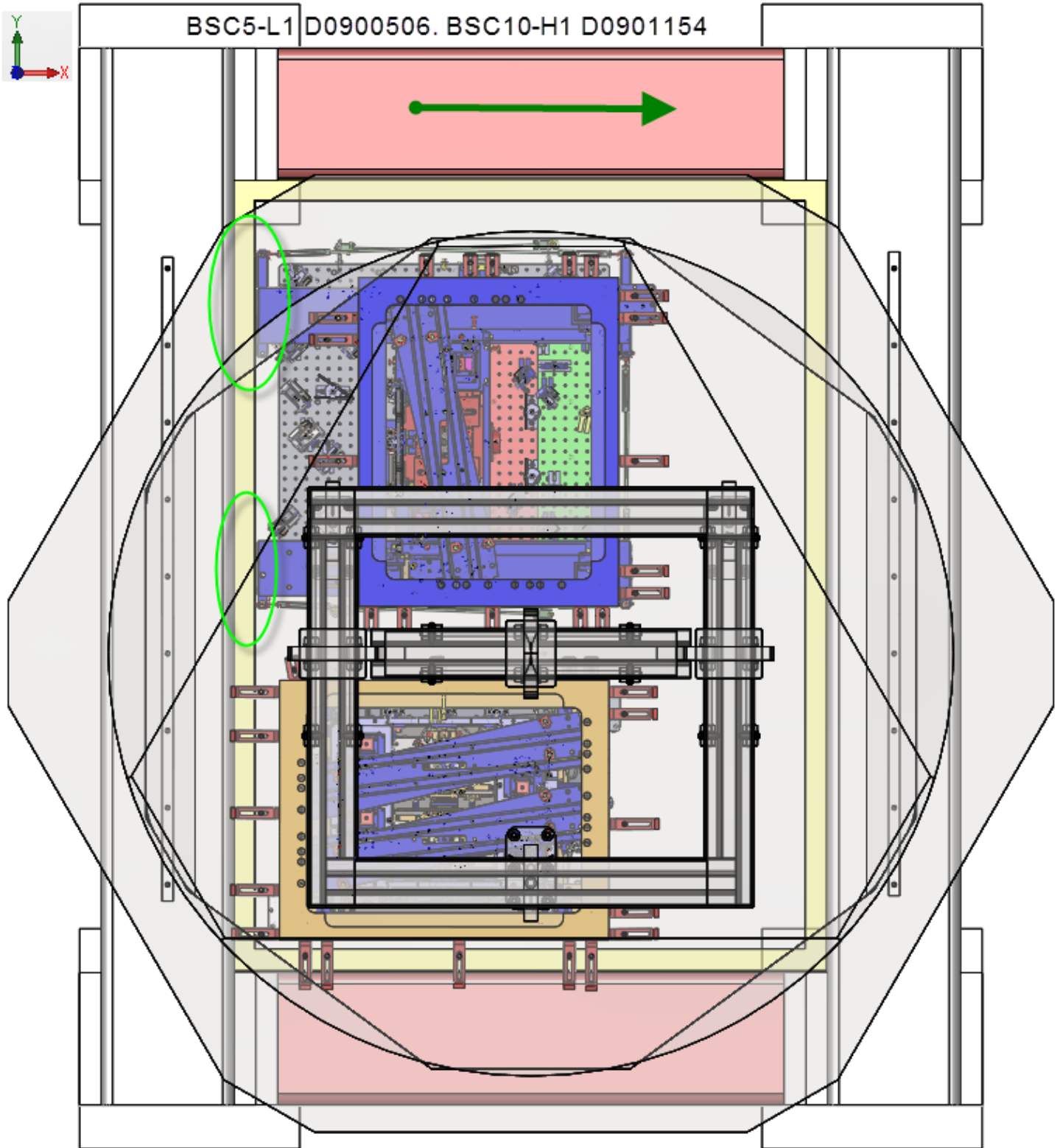

Circles in green indicate any protrusion into the keep out zone. Any global XY moves relative to the Test-Stand will depend on the orientation of the Test-Stand.

BSC5-L1 D0900506, BSC10-H1 D0901154, will not need to be rotated before insertion into the chamber because the test stand is oriented parallel to the support tubes in the BSC chamber.

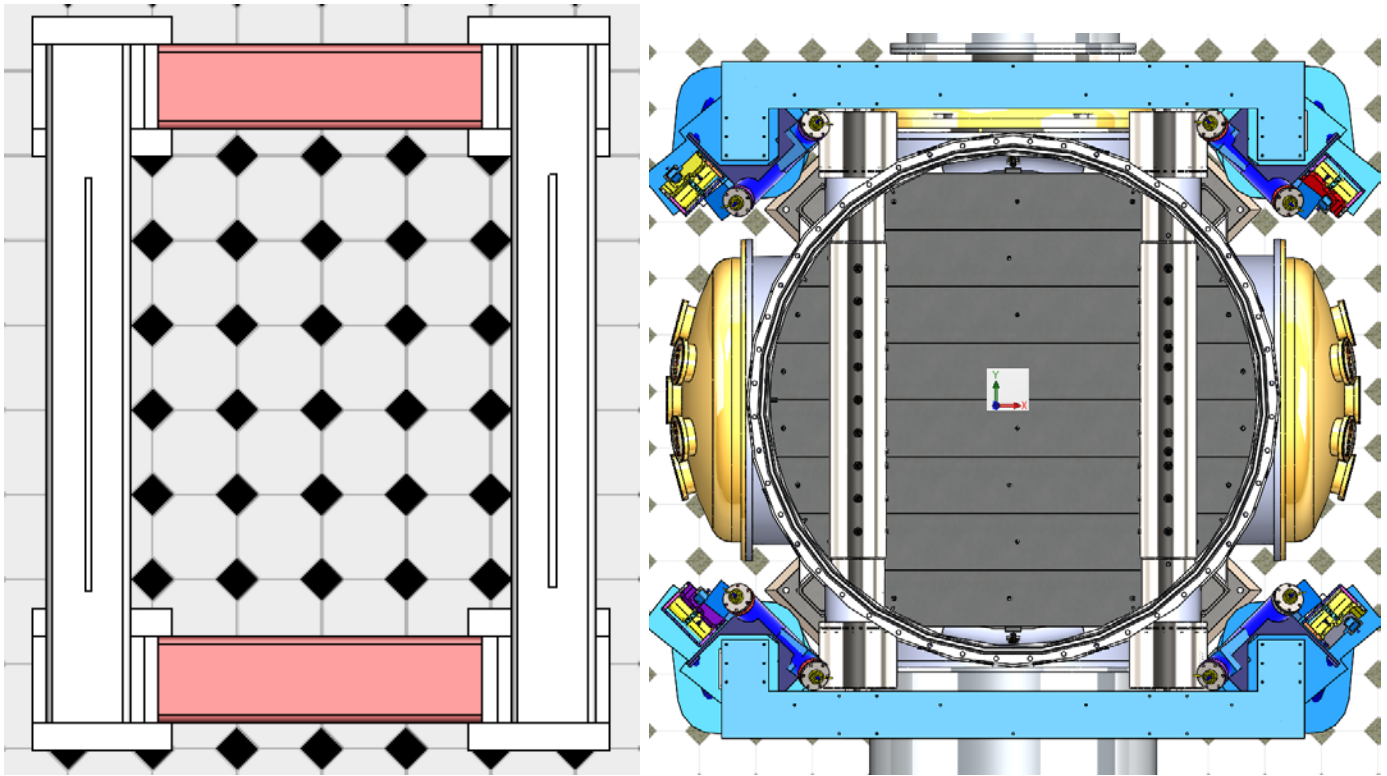

BSC6
 H2:ISI-ETMY
 h2isietmy.mdl
 BSC-ISI/H2/ETMY/



BSC10
 H1:ISI-ETMY
 h1isietmy.mdl
 BSC-ISI/H1/ETMY/



BSC5
 L1:ISI-ETMY
 l1isietmy.mdl
 BSC-ISI/L1/ETMY/

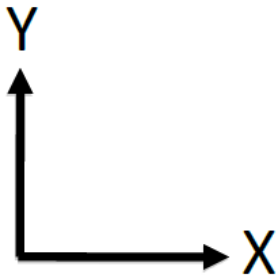
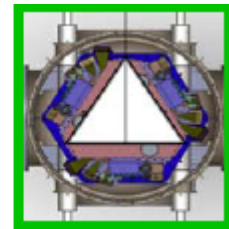

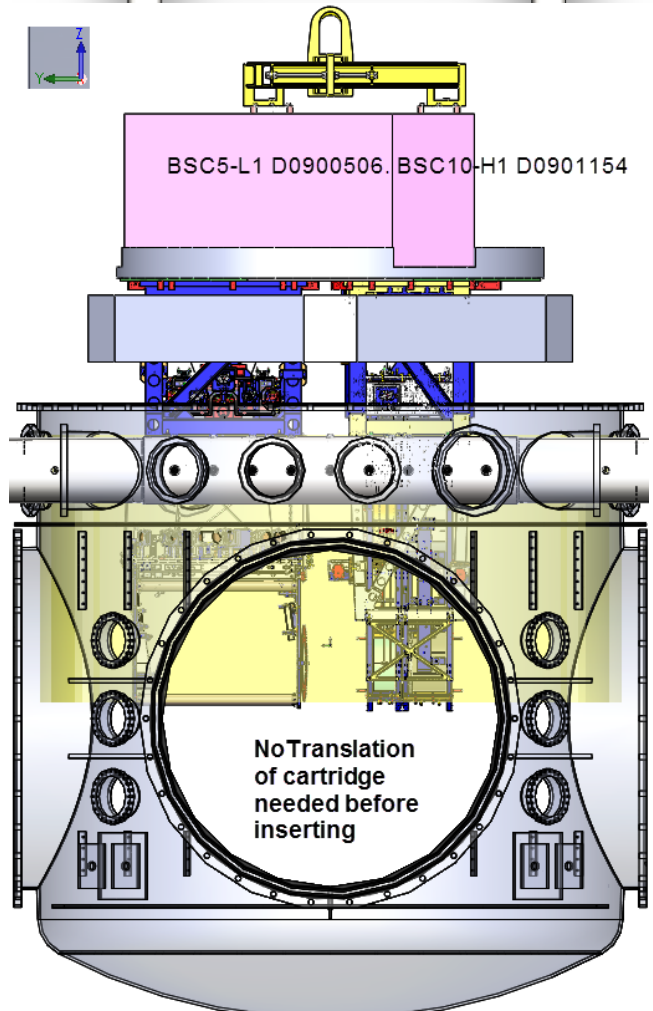
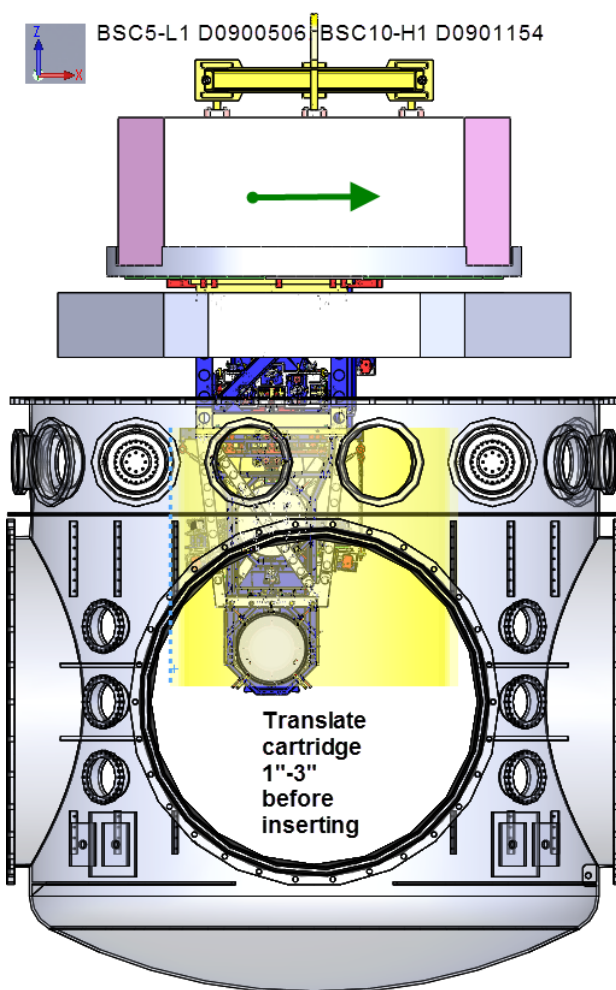
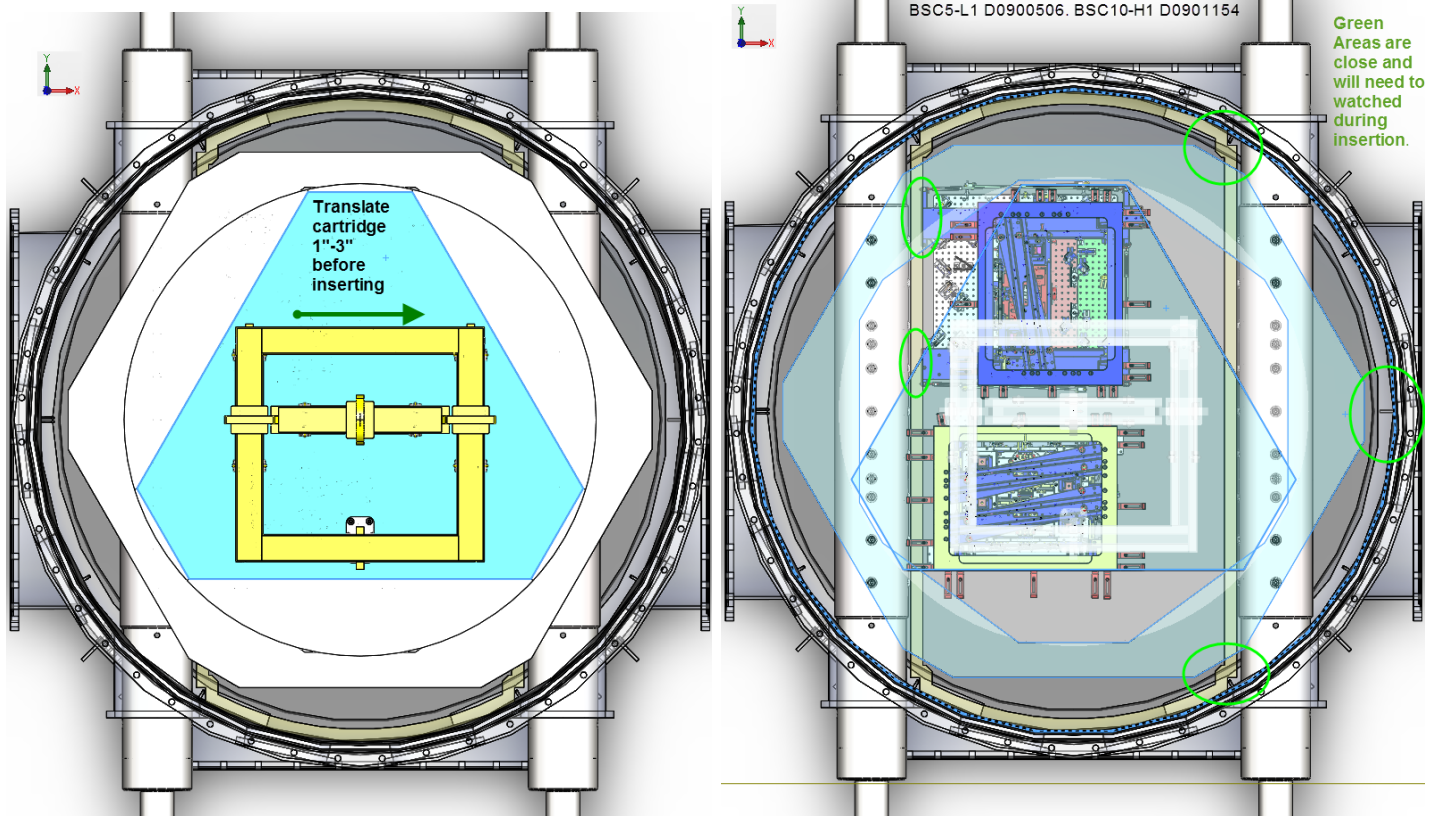

Locating the Bale pre-lift of the cartridge (Some adjustment will be needed)

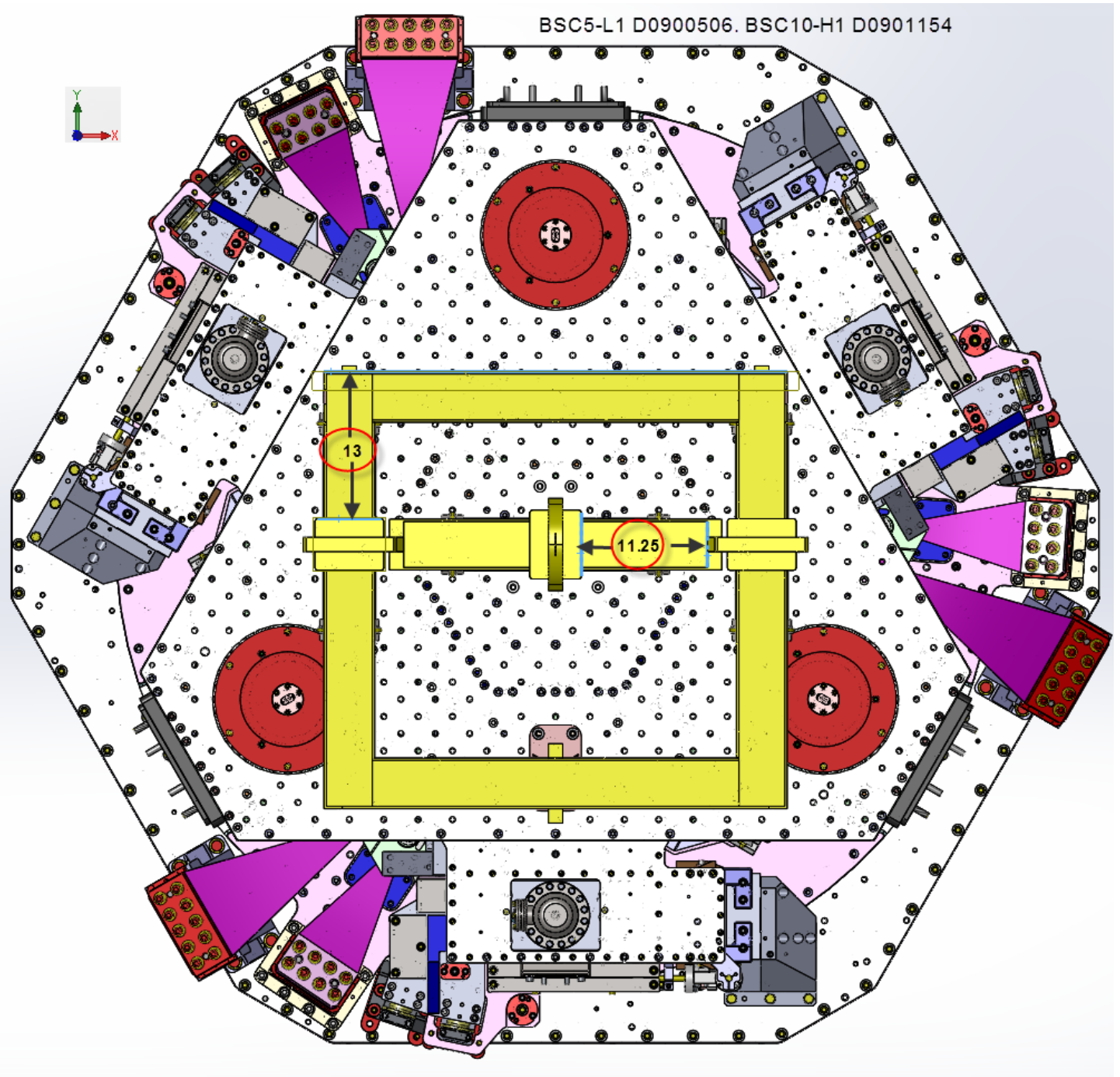

Items that will need to be locked down when the cartridge is moved:

1. **BSC-ISI:** (see [E1200344](#) sections 4.2)

completed, approved or checked by:

date:

comments (optional):

2. **ITMY:** Final checks before moving ([T1100406](#)):

completed, approved or checked by:

date:

comments (optional):

Cartridge: Preparation for, and installation into Chamber:

aLIGO BSC ISI/Quad Install Procedure: (see [E1200344](#))

completed, approved or checked by:

date:

comments (optional):