

6 5 4 3 2 1

BILLING NUMBERS

PROJECT: LIGO5F600
 TASK: 1.4
 AWARD: NSFLIGO.5F6000

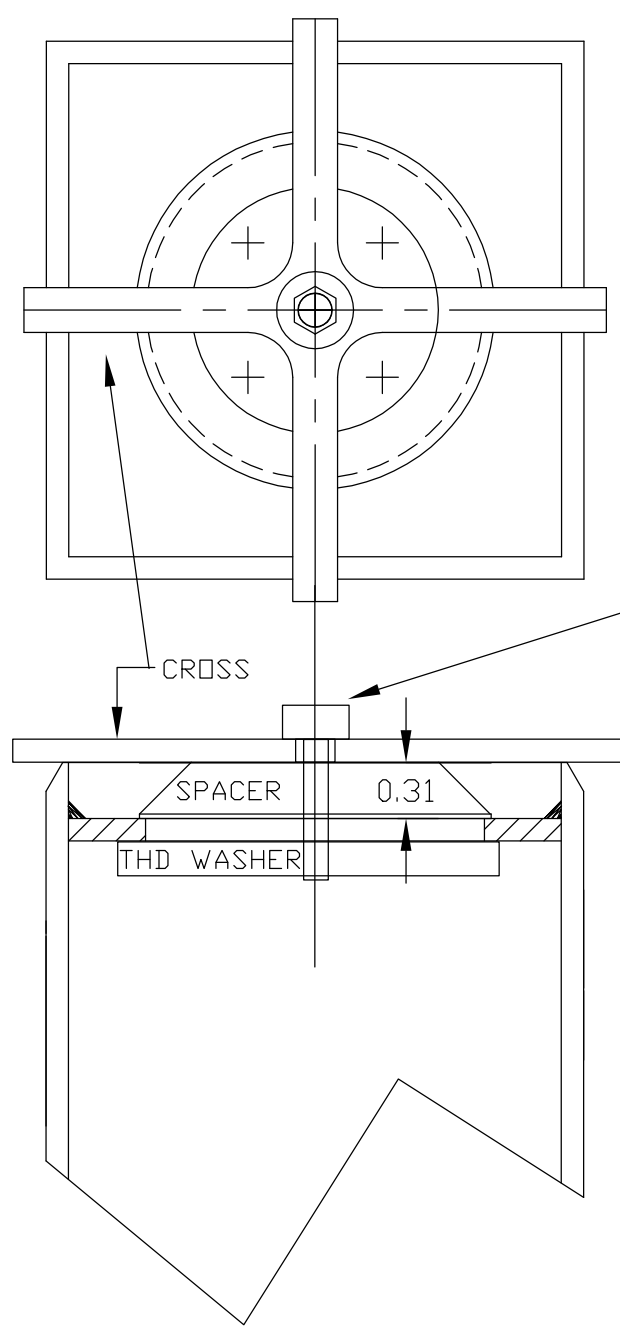

10-24 CAP SCREW .75 LONG

CROSS

SPACER

0.31

THD WASHER

TOP CAP WELD FIXTURE ASSEMBLY

4	1	-	-	-
3	2	-	-	-
2	1	-	-	-
1	1	-	-	-
REF.	QTY.	PART or DRWG No.	NOMENCLATURE or DESCRIPTION	MATERIAL

PARTS and MATERIAL LIST

		UNLESS OTHERWISE SPECIFIED DIMENSIONS ARE IN INCHES								LIGO CALIFORNIA INSTITUTE OF TECHNOLOGY MASSACHUSETTS INSTITUTE OF TECHNOLOGY	
		TOLERANCES: FRACTIONAL ± / ANGULAR ± 2 deg. ANGULARMACH ± BEND ± / TWO PLACE DECIMAL ± .02		THREE PLACE DECIMAL ± .005 FINISHED SURFACE RMS / BREAK CORNERS IN: OUT: / REMOVE ALL BURRS /						TOP CAP WELD FIXTURE	
		MATERIAL: 6061-T6 alum	HEAT TREAT: /	FINISH: /	00	RELEASE	E010214-00-D	kenm	10/31/01	CAD FILE: D010255-A B SIZE/DWG. NO. D010255-A	
DWG. NO.	DESCRIPTION	USED ON: XXX	NEXT ASS'Y: XXX	REV	DESCRIPTION	DCN NUMBER	APPR'D	CHECK	DRWN	DATE	SHEET SHEET#
REFERENCE DRAWINGS				ISSUE DESCRIPTION						SCALE: 4X	

6 5 4 3 2 1