

D1300075 - Cable Harness Routing Configuration - HAM1, PART PDM REV: X-006, DRAWING PDM REV: X-004

REV.	DATE	DCN #	DRAWING TREE #
v1	31 JAN 2013	-	-
v3	30 SEP 2013	E1300736-x0	-
v4	30 OCT 2013	E1300820-x0	-

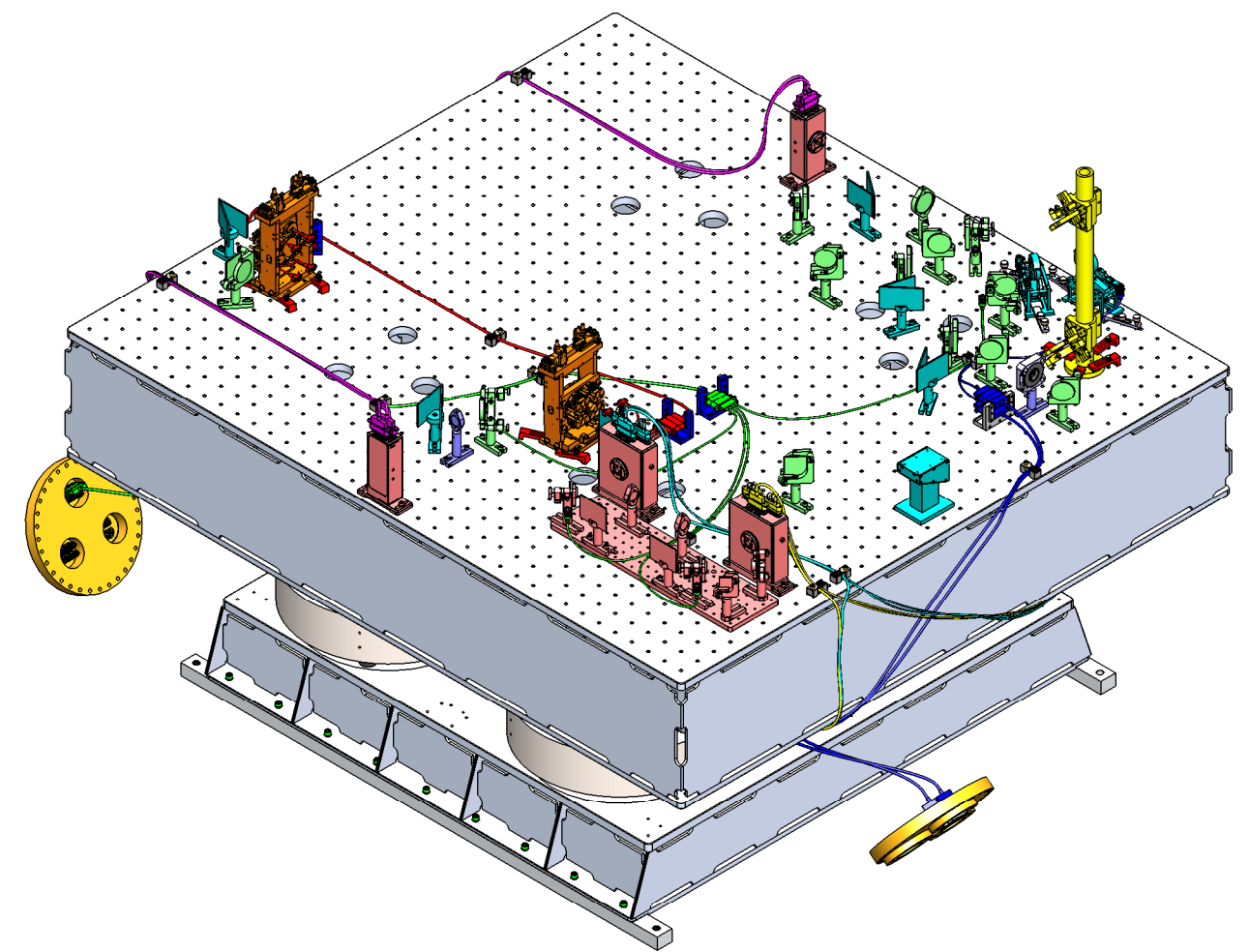
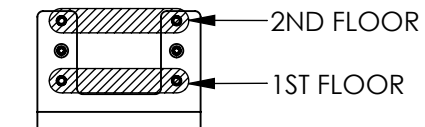
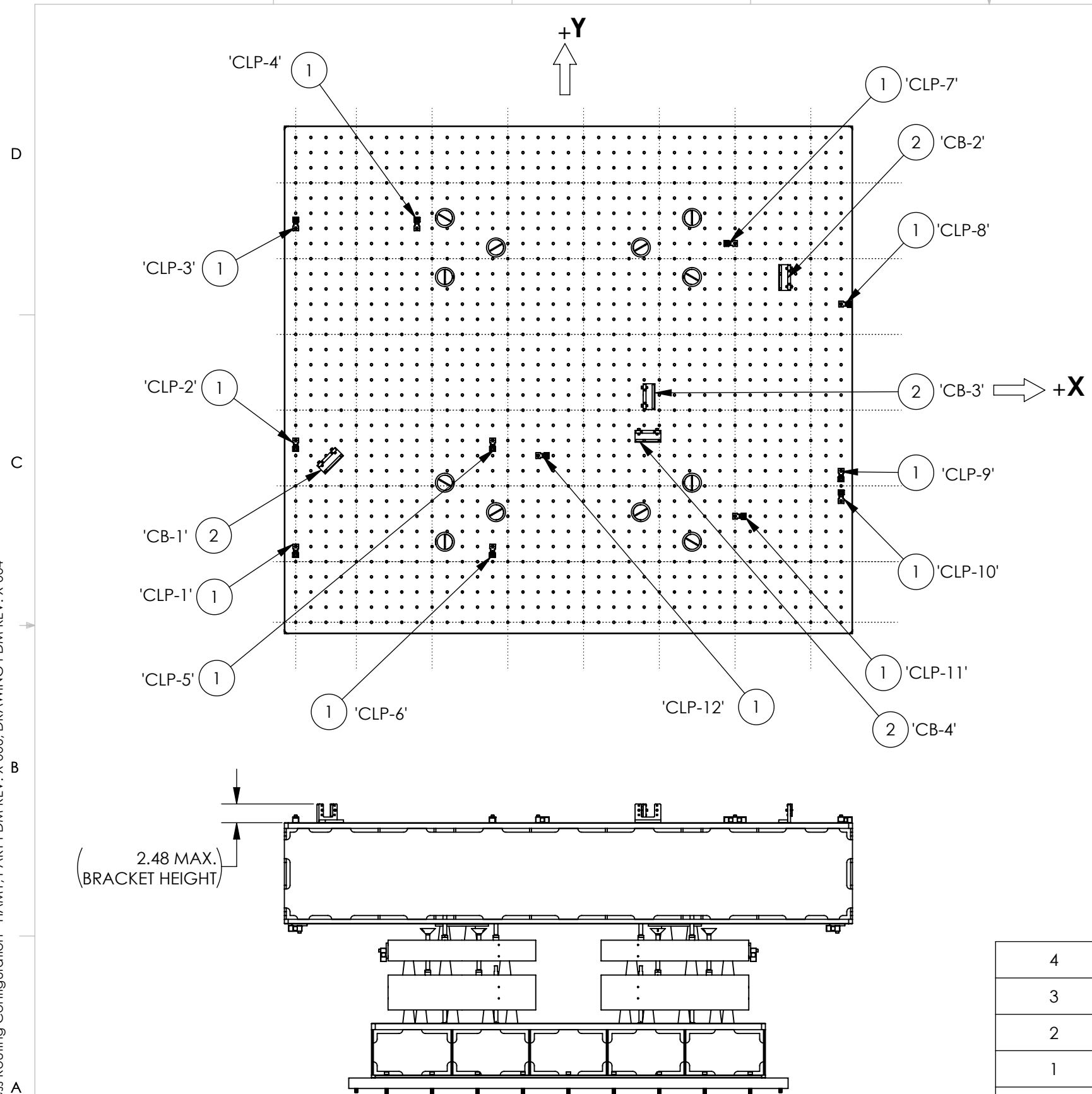

ISOMETRIC VIEW

ITEM NO.	PART NUMBER	DESCRIPTION	QTY.
4	92210A302 MCMaster-CARR OR EQ.	SCREW, FSHC, 10-32 X .50 LG.	16
3	TBD	CABLE CLAMP MT., INTERFACE PLATE	8
2	D1001346-1	αLIGO, ASSY, CABLE BRACKET, HAM TABLE	4
1	D0902462	CABLE CLAMP ASSY., UHV COMPATIBLE	20

PARTS LIST

- FOR A DETAILED DESCRIPTION OF ISC HAM1 IN VACUUM COMPONENTS, SEE D1000313
- FOR END STATION ISC ELECTRONICS WIRING, SEE D1100670
- FOR ISC HAM 1 BLOCK DIAGRAM, SEE D1000313

NOTES AND TOLERANCES: (UNLESS OTHERWISE SPECIFIED)

MATERIAL	N/A	FINISH	N/A μinch
----------	-----	--------	-----------

CALIFORNIA INSTITUTE OF TECHNOLOGY MASSACHUSETTS INSTITUTE OF TECHNOLOGY		PART NAME		CABLE HARNESS ROUTING, HAM 1	
SYSTEM	ADVANCED LIGO	SUB-SYSTEM	SUS	DESIGNER	ESANCHEZ
DRAFTER	ESANCHEZ	DATE	JAN 31 2013	SIZE	DWG. NO.
CHECKER	SEE DCC			<b>B</b>	<b>D1300075</b>
APPROVAL	SEE DCC			REV.	v4
NEXT ASSY				SCALE:	1:24
D0901809, D0901821				PROJECTION:	1ST ANGLE
					SHEET 1 OF 12

# ROUTE NO. 1

+Y  
↑

+X  
→

⑤ IN-VAC CABLES SHALL BE CLAMPED ON BOTH STAGES OF PROOF MASS BETWEEN THE SPRINGS TO AVOID POTENTIALLY SHORTING THE SEISMIC ISOLATION OF THE HAM STACK. HOWEVER, IF CABLE LENGTH IS NOT LONG ENOUGH THEN ROUTING VIA ONE MASS IS SUFFICIENT. IF THE LATTER IS FOLLOWED, ONE MUST NOTE THIS ON THE DRAWING AND SUPPLY ALT. TO SYSTEMS.

D

C

B

A

D

C

B

A

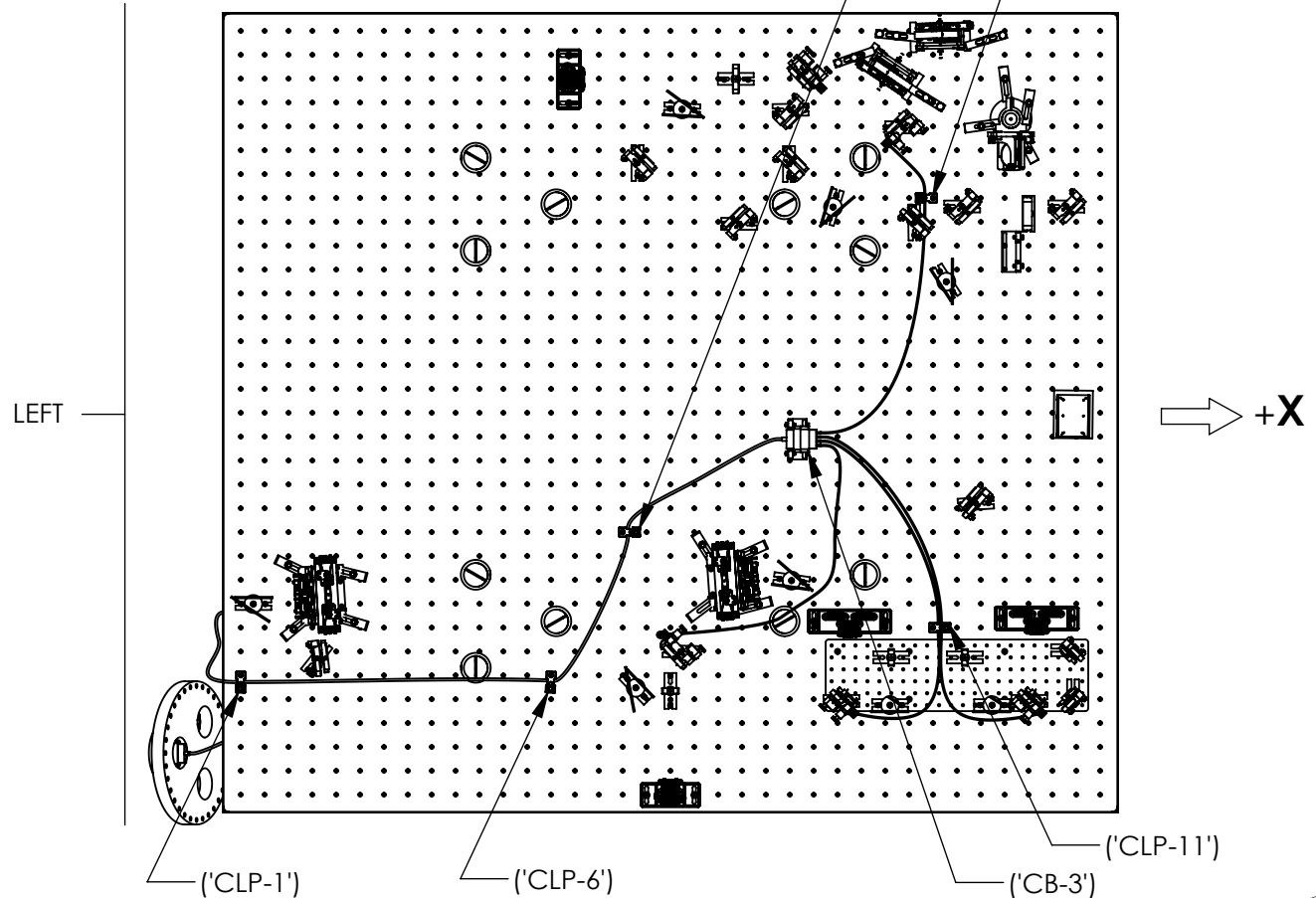

TOP VIEW

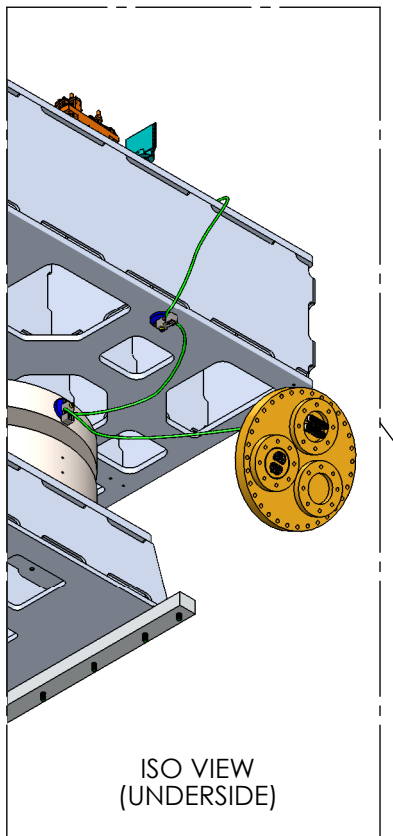

ISO VIEW (UNDERSIDE)

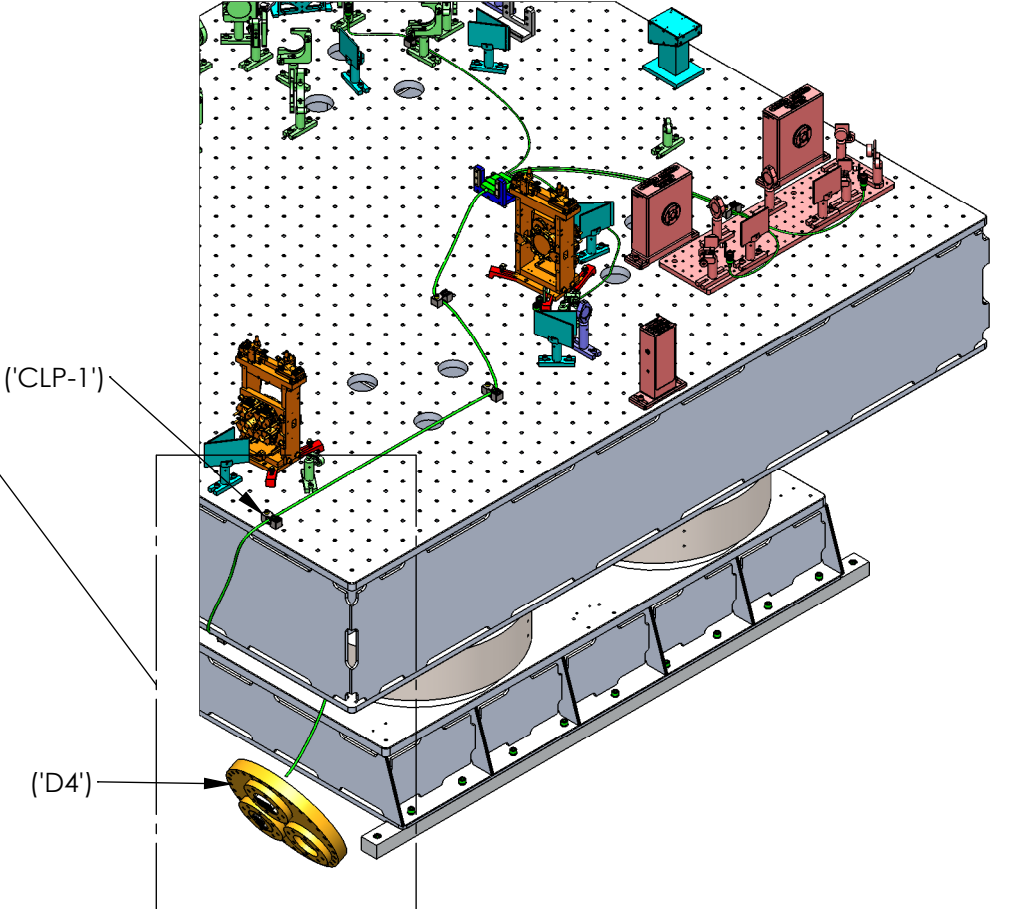

ISO VIEW, FRONT - LEFT

- 1 'CLP-13'
- 4 2X
- 3 MT. TO BOTTOM OF HAM OPTICS TABLE

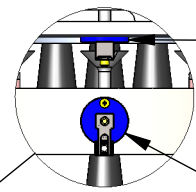

DETAIL A  
SCALE 1 : 8

- 3 MT. ON PASSIVE STACK
- 4 2X
- 1 'CLP-14'

ROUTING DOWN THE HAM ISI SHOWN ONLY FOR REF. BEST POSSIBLE ROUTE TBD AT TIME OF INSTALLATION

⑤

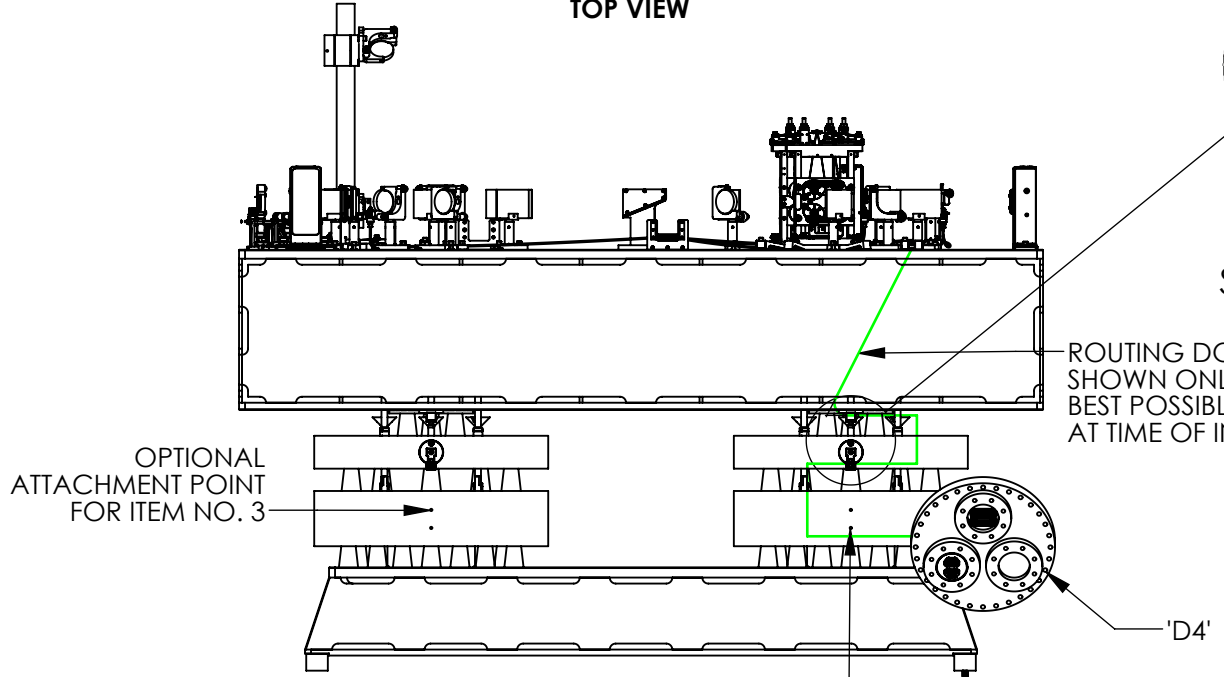

LEFT SIDE (ROTATED 90 DEGREES CCW)

OPTIONAL ATTACHMENT POINT FOR ITEM NO. 3

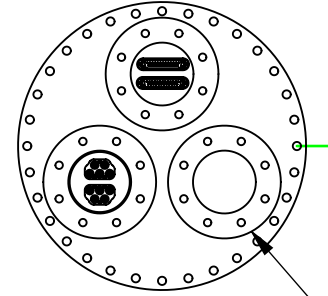

D4\* AS VIEWED FROM THE AIRSIDE

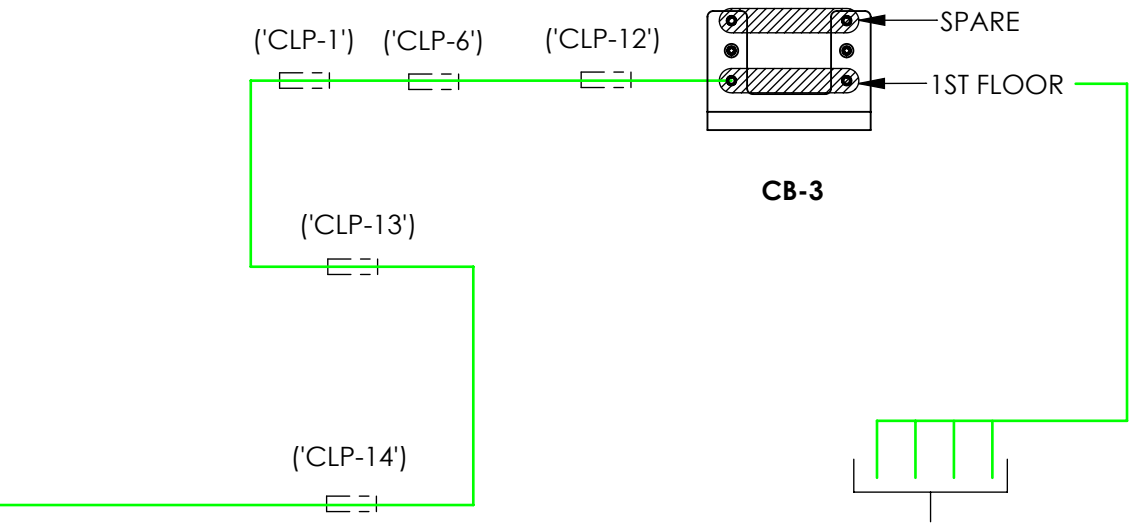

ROUTE NO.1  
SEE TABLE 1 FOR CABLING SPECS.  
(ROUTE CABLE/ CABLES THROUGH REFERENCED CABLE CLAMPS)  
CABLE QTY.: 1

TO PICOMOTORS (SEE SHEET 7)

\*SEE D1101775, FOR FLANGE/SUBFLANGE PORT DESIGNATION.

**LIGO** CALIFORNIA INSTITUTE OF TECHNOLOGY  
MASSACHUSETTS INSTITUTE OF TECHNOLOGY

SIZE DWG. NO. <b>B</b>	D1300075	REV. <b>v4</b>
SCALE: 1:24	PROJECTION:	SHEET 2 OF 12

D1300075 - Cable Harness Routing Configuration - HAM1, PART PDM REV: X-006, DRAWING PDM REV: X-004

D1300075 - Cable Harness Routing Configuration - HAM1, PART PDM REV: X-006, DRAWING PDM REV: X-004

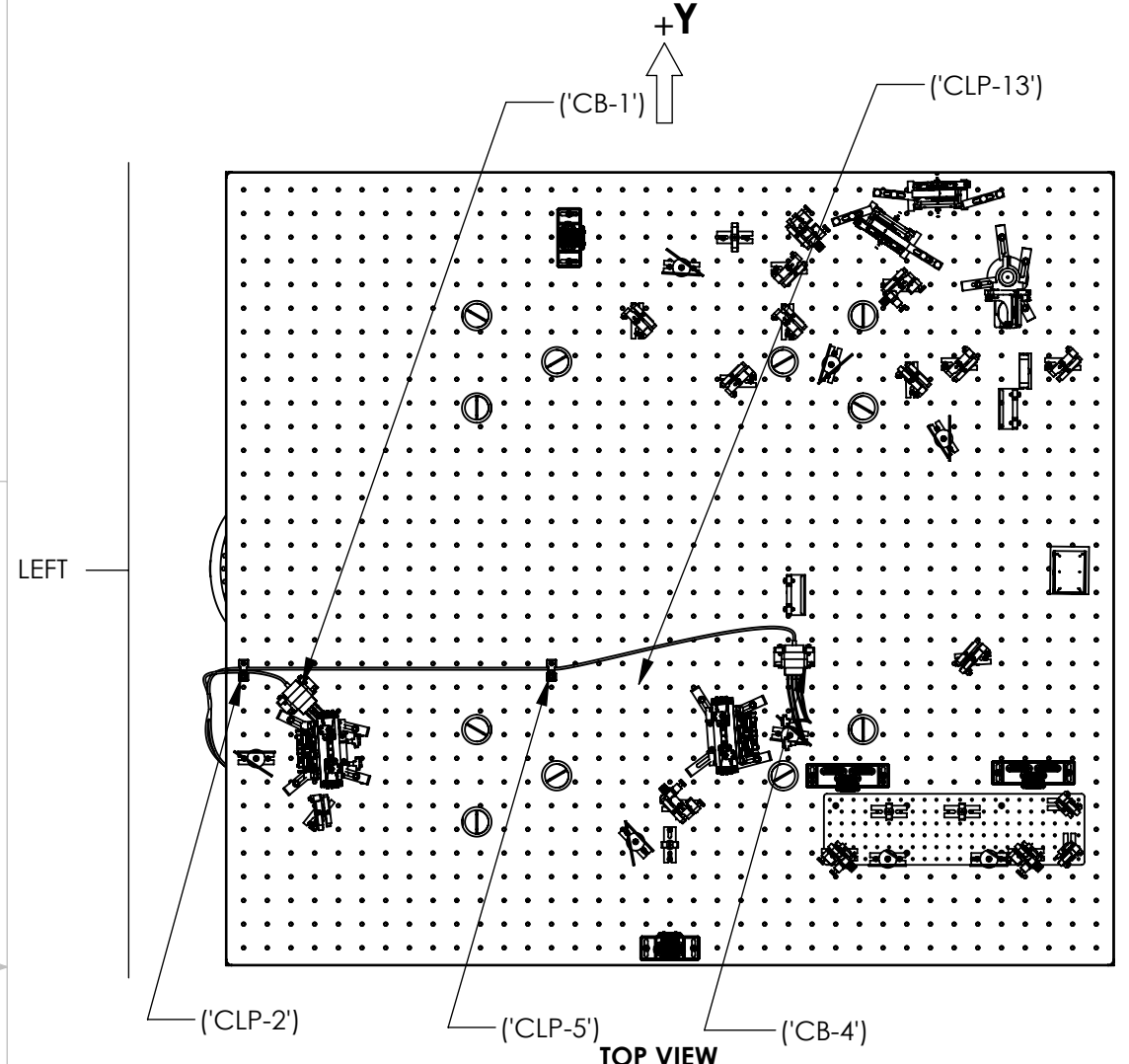

⑤ IN-VAC CABLES SHALL BE CLAMPED ON BOTH STAGES OF PROOF MASS BETWEEN THE SPRINGS TO AVOID POTENTIALLY SHORTING THE SEISMIC ISOLATION OF THE HAM STACK. HOWEVER, IF CABLE LENGTH IS NOT LONG ENOUGH THEN ROUTING VIA ONE MASS IS SUFFICIENT. IF THE LATTER IS FOLLOWED, ONE MUST NOTE THIS ON THE DRAWING AND SUPPLY ALT. TO SYSTEMS.

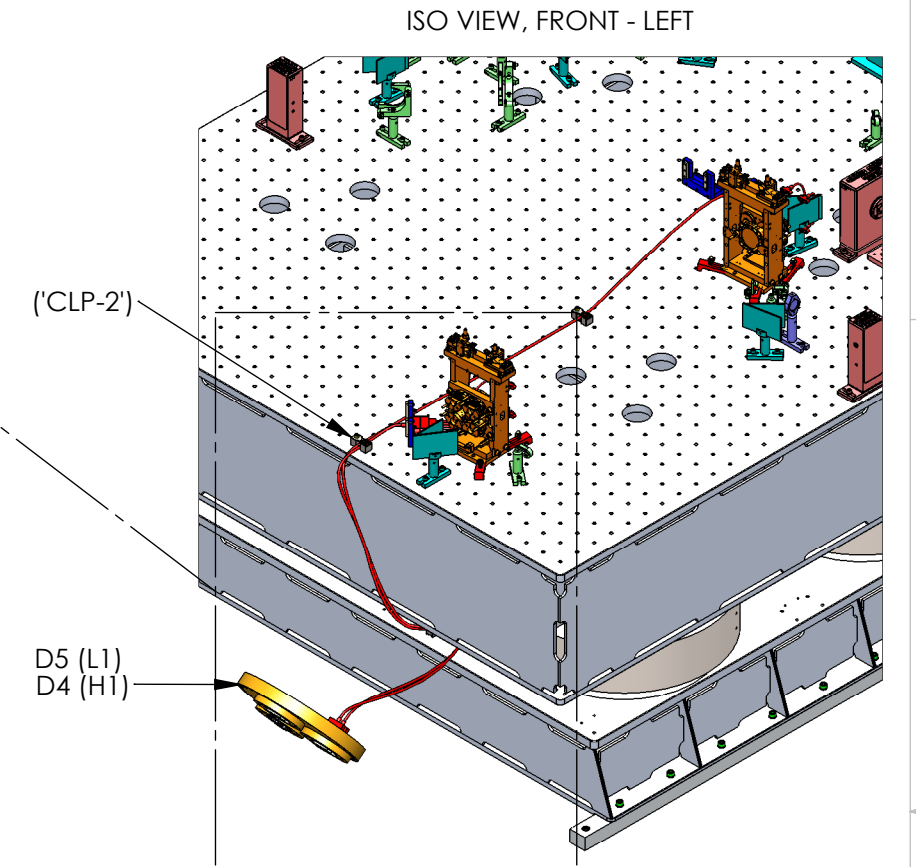
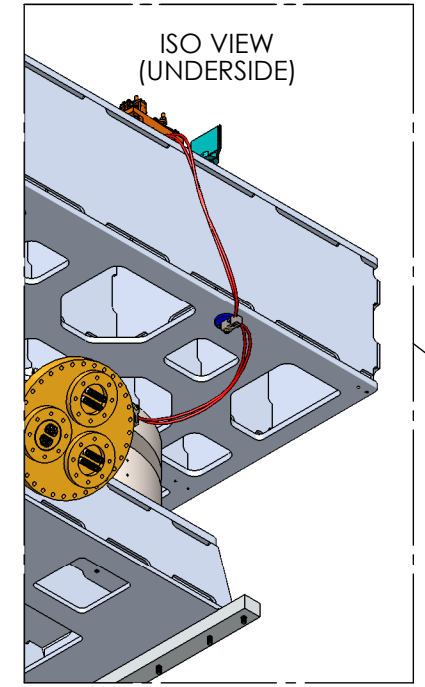

ROUTE NO.2  
SEE TABLE 1 FOR CABLING SPECS.  
(ROUTE CABLE/ CABLES THROUGH REFERENCED CABLE CLAMPS)  
CABLE QTY.: 2

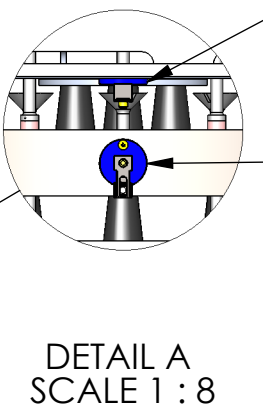
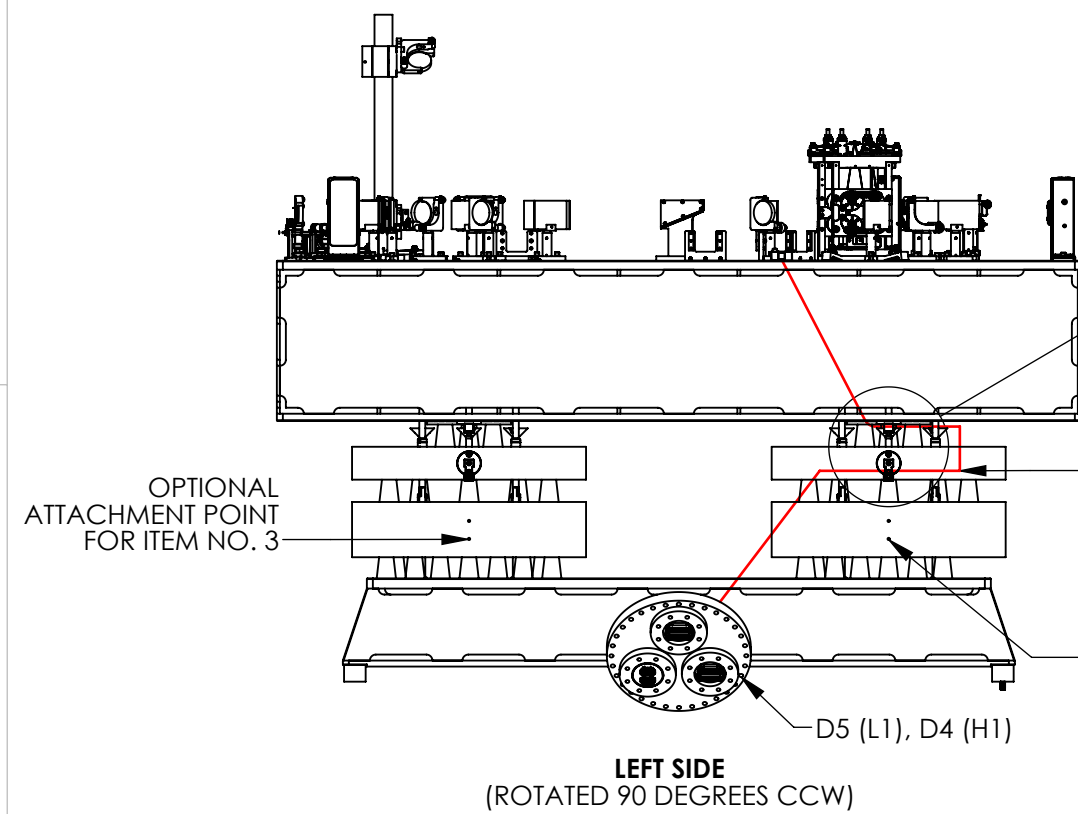

- ① 'CLP-13'
- ④ 2X
- ③ MT. TO BOTTOM OF HAM OPTICS TABLE
- ③ MT. ON PASSIVE STACK
- ④ 2X
- ① 'CLP-14'

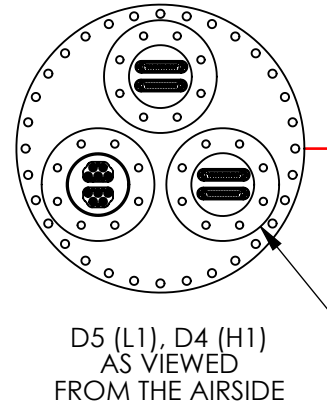

D5: PURGE AIR PORT  
D4: TIP/TILT MIRRORS

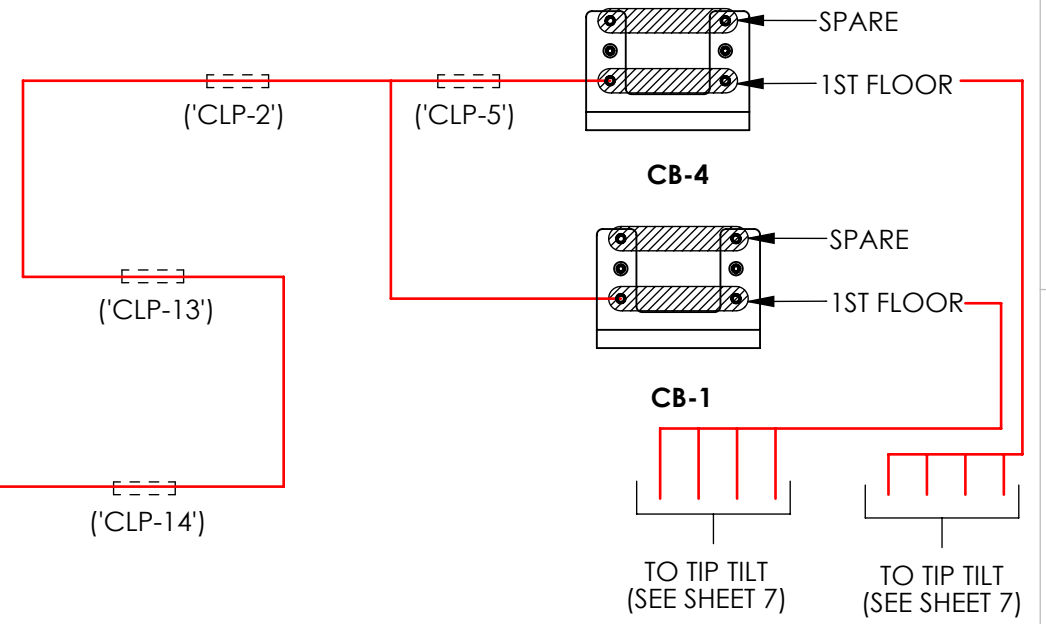

\*SEE D1101775, FOR FLANGE/SUBFLANGE PORT DESIGNATION.

## ROUTE NO. 2

**LIGO** CALIFORNIA INSTITUTE OF TECHNOLOGY  
MASSACHUSETTS INSTITUTE OF TECHNOLOGY

SIZE DWG. NO.	D1300075	REV.	v4
SCALE: 1:24		PROJECTION:	
		SHEET 3 OF 12	

# ROUTE NO. 3

+Y  
↑

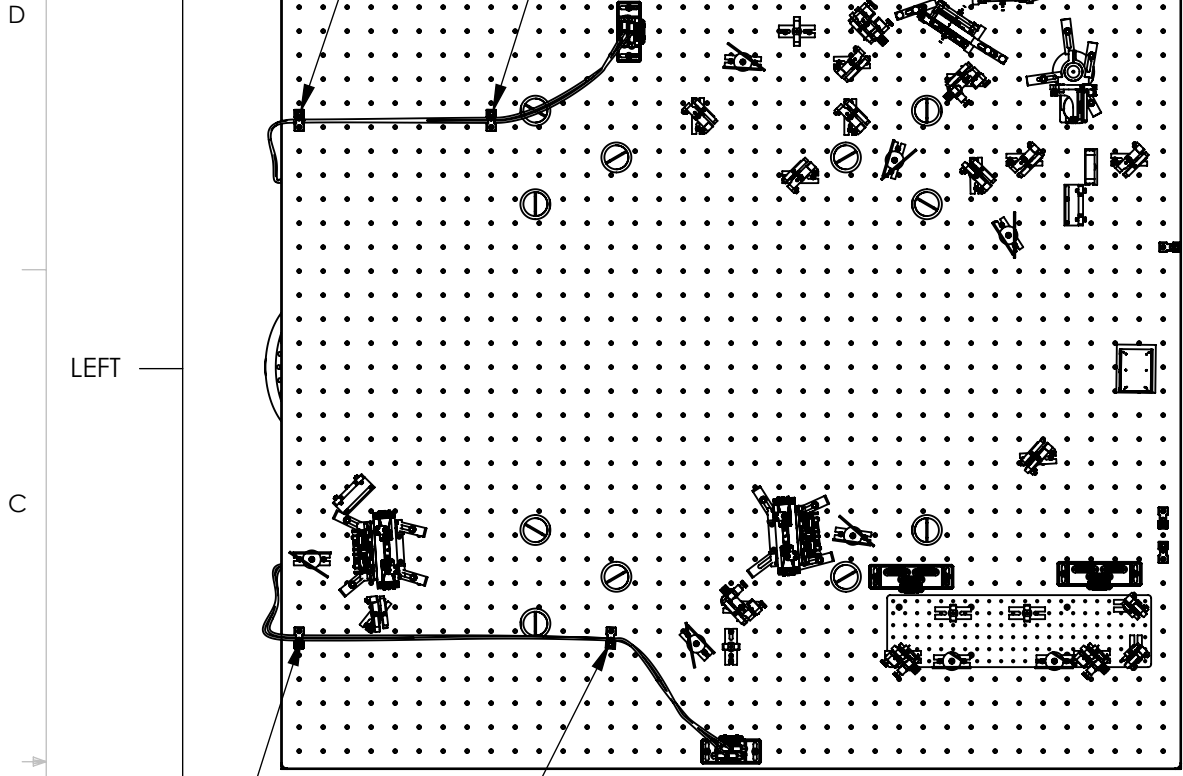

+X  
→

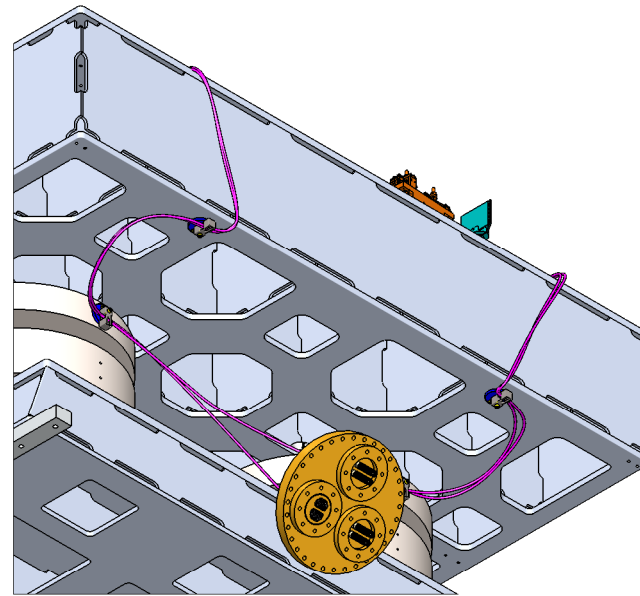

ISO VIEW  
(UNDERSIDE)

⑤ IN-VAC CABLES SHALL BE CLAMPED ON BOTH STAGES OF PROOF MASS BETWEEN THE SPRINGS TO AVOID POTENTIALLY SHORTING THE SEISMIC ISOLATION OF THE HAM STACK. HOWEVER, IF CABLE LENGTH IS NOT LONG ENOUGH THEN ROUTING VIA ONE MASS IS SUFFICIENT. IF THE LATTER IS FOLLOWED, ONE MUST NOTE THIS ON THE DRAWING AND SUPPLY ALT. TO SYSTEMS.

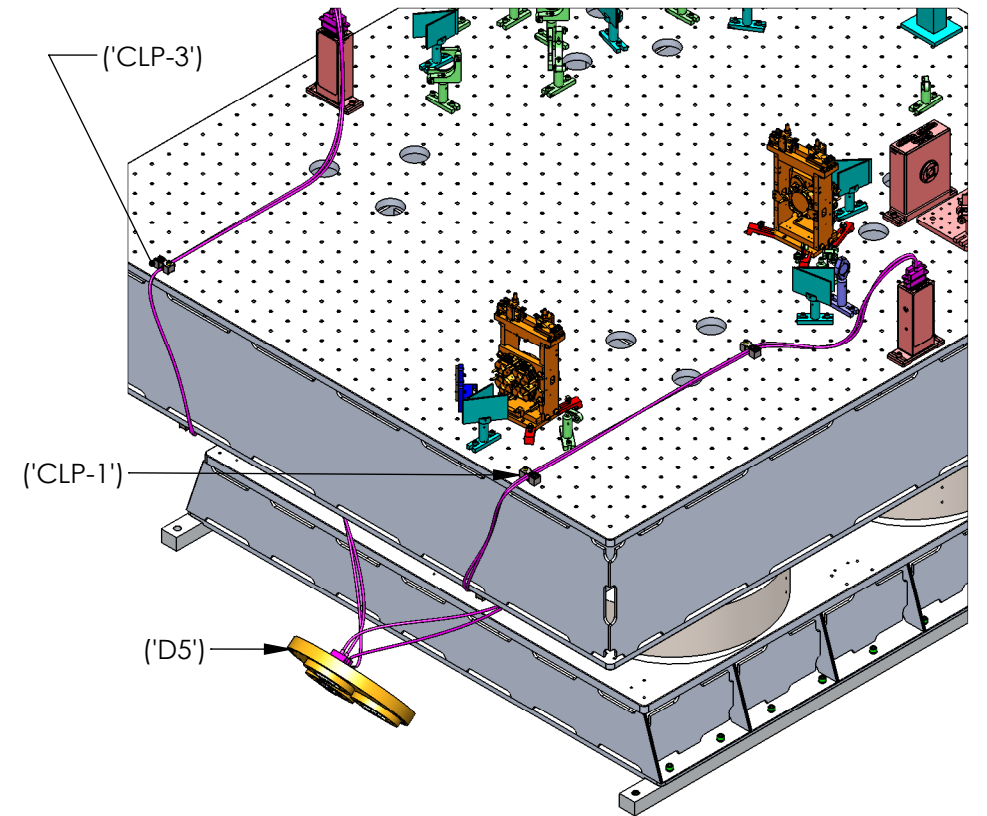

ISO VIEW, FRONT - LEFT

TOP VIEW

ROUTING DOWN THE HAM ISI  
SHOWN ONLY FOR REF.  
BEST POSSIBLE ROUTE TBD  
AT TIME OF INSTALLATION

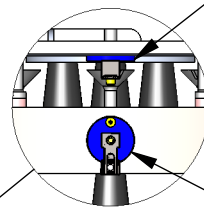
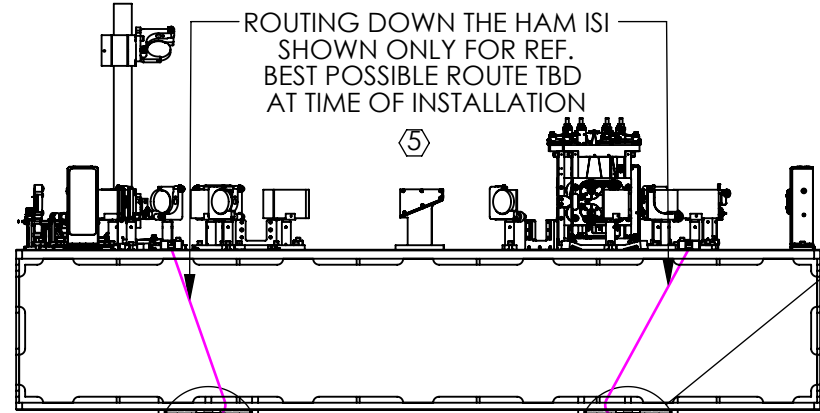

DETAIL A  
SCALE 1 : 8

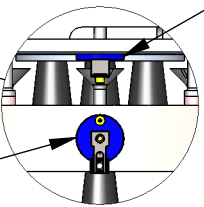

DETAIL B  
SCALE 1 : 8

- 1 'CLP-13'
- 4 2X
- 3 MT. TO BOTTOM OF HAM OPTICS TABLE

- 3 MT. ON PASSIVE STACK
- 4 2X
- 1 'CLP-14'

- 1 'CLP-15'
- 4 2X
- 3 MT. TO BOTTOM OF HAM OPTICS TABLE

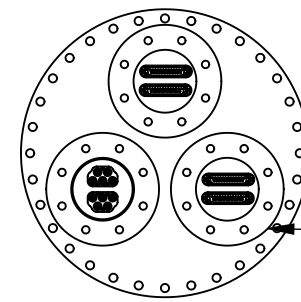

D5\*  
AS VIEWED  
FROM THE AIRSIDE

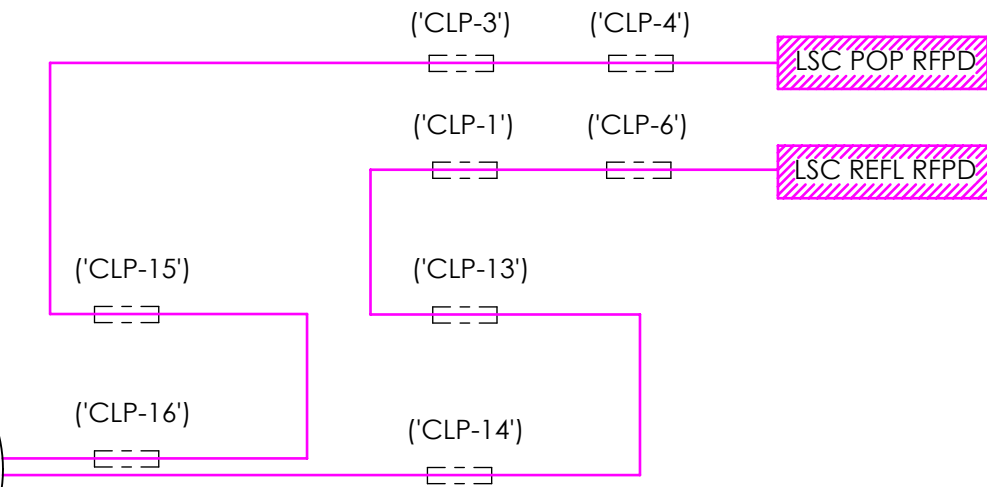

ROUTE NO.3  
SEE TABLE 1 FOR CABLING SPECS.  
(ROUTE CABLE/ CABLES THROUGH REFERENCED CABLE CLAMPS)  
CABLE QTY.: 4

OPTIONAL  
ATTACHMENT POINT  
FOR ITEM NO. 3

OPTIONAL  
ATTACHMENT POINT  
FOR ITEM NO. 3

'D5'  
LEFT SIDE  
(ROTATED 90 DEGREES CCW)

MT. ON  
PASSIVE STACK  
2X

'CLP-16'  
1

\*SEE D1101775, FOR FLANGE/SUBFLANGE PORT DESIGNATION.

# ROUTE NO. 4



⑤ IN-VAC CABLES SHALL BE CLAMPED ON BOTH STAGES OF PROOF MASS BETWEEN THE SPRINGS TO AVOID POTENTIALLY SHORTING THE SEISMIC ISOLATION OF THE HAM STACK. HOWEVER, IF CABLE LENGTH IS NOT LONG ENOUGH THEN ROUTING VIA ONE MASS IS SUFFICIENT. IF THE LATTER IS FOLLOWED, ONE MUST NOTE THIS ON THE DRAWING AND SUPPLY ALT. TO SYSTEMS.

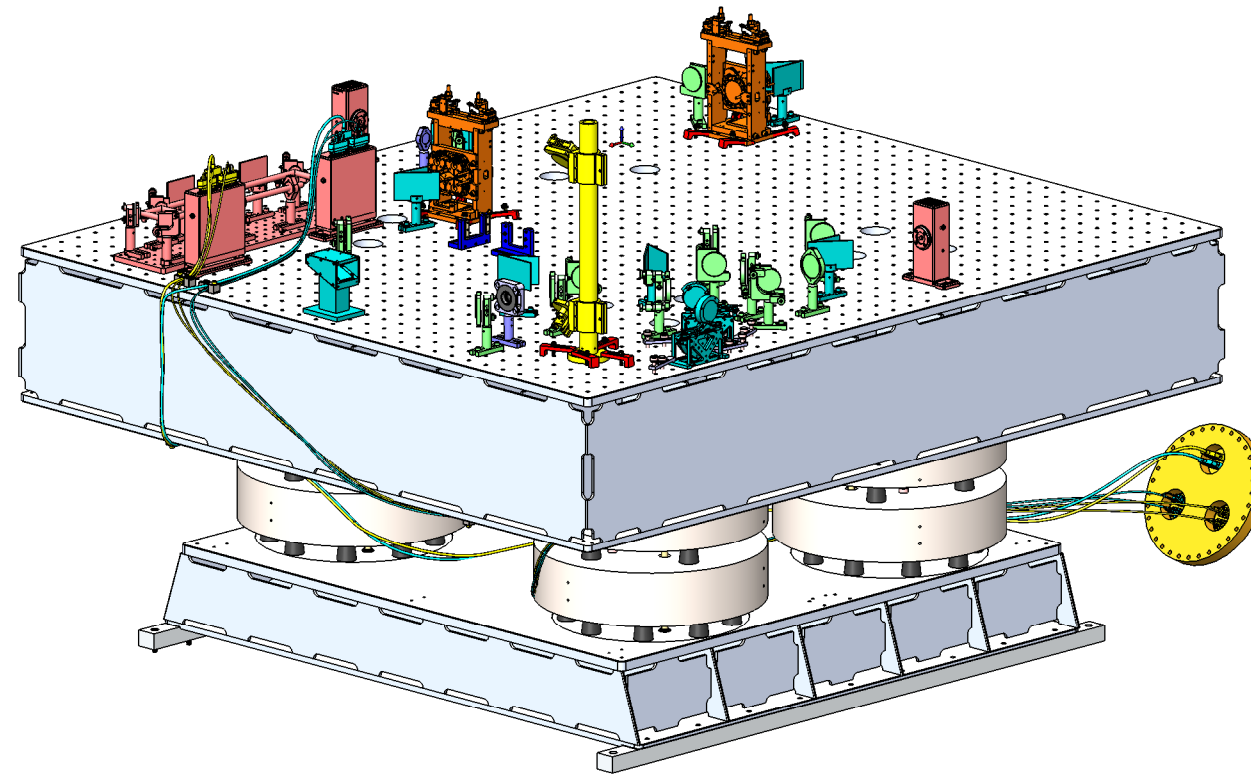
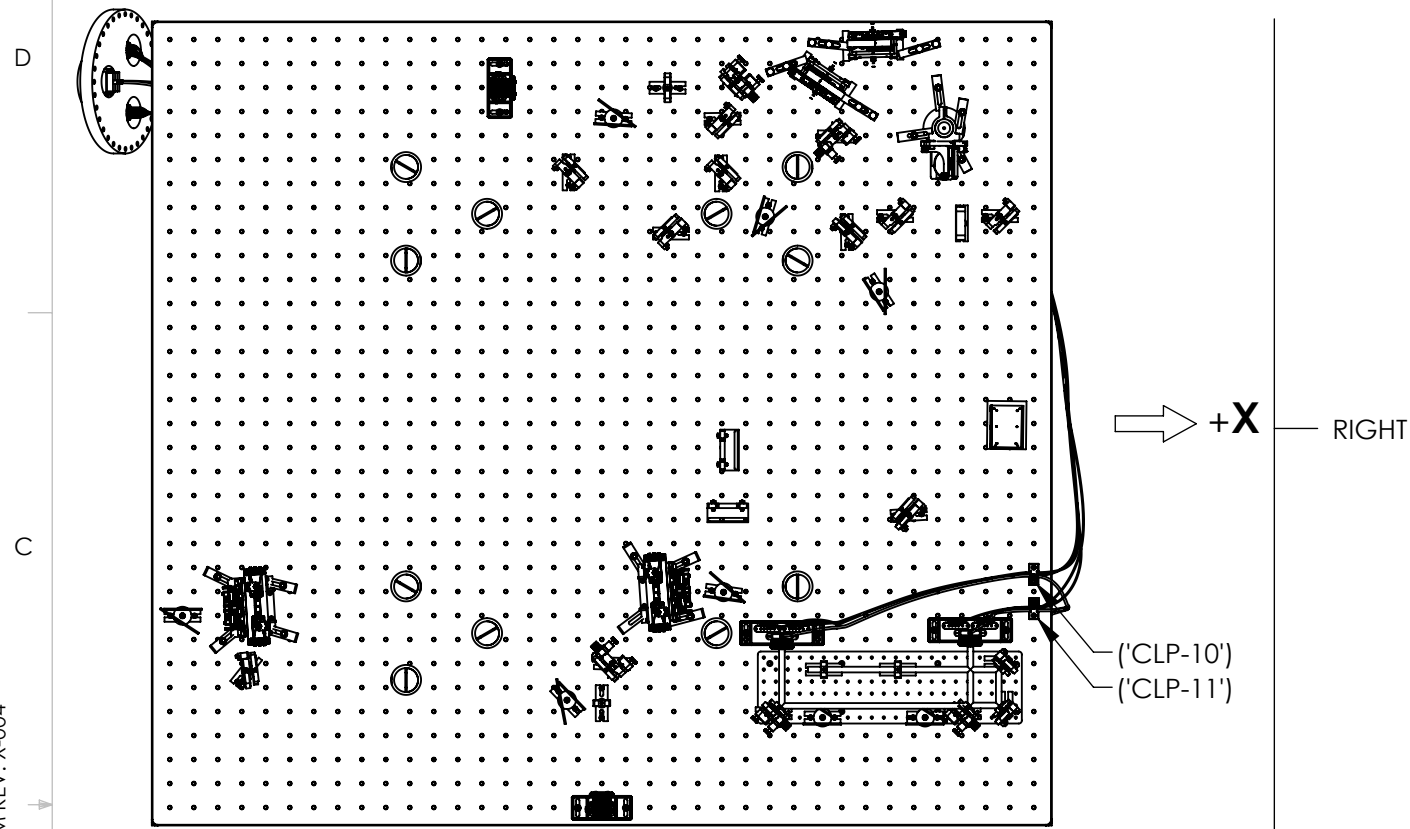

ISO VIEW, REAR-RIGHT

TOP VIEW

ROUTE NO.4  
SEE TABLE 1 FOR CABLING SPECS.  
(ROUTE CABLE/ CABLES THROUGH REFERENCED CABLE CLAMPS)  
CABLE QTY.: 6

ROUTING DOWN THE HAM ISI  
SHOWN ONLY FOR REF.  
BEST POSSIBLE ROUTE TBD  
AT TIME OF INSTALLATION

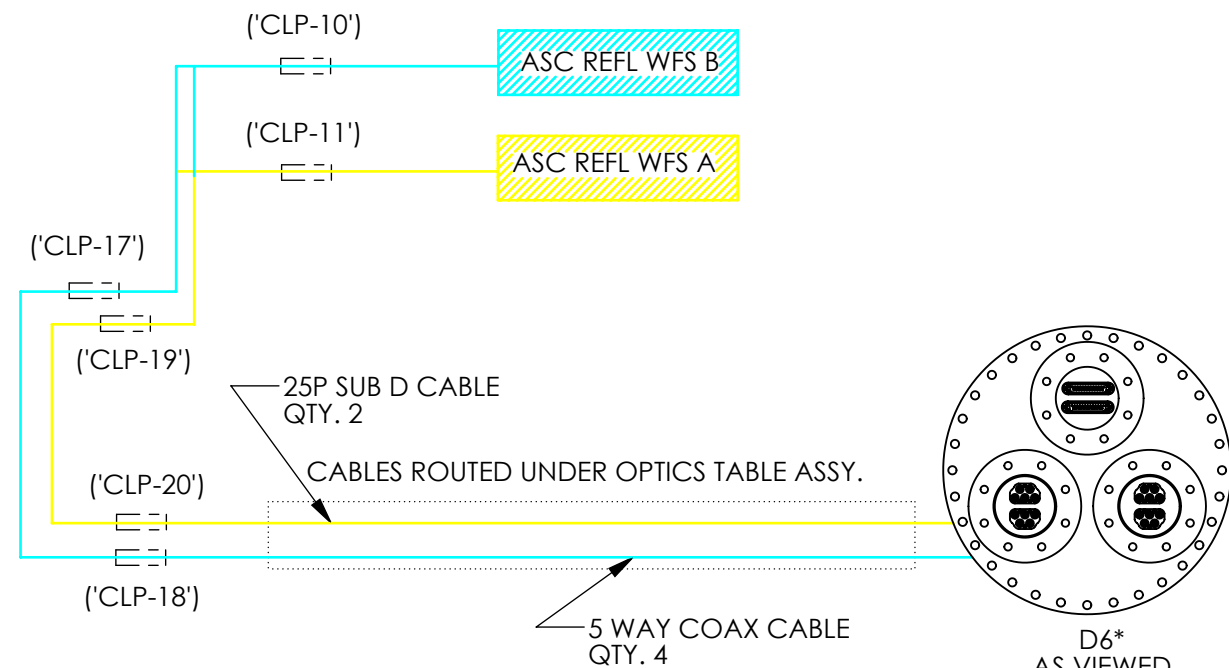
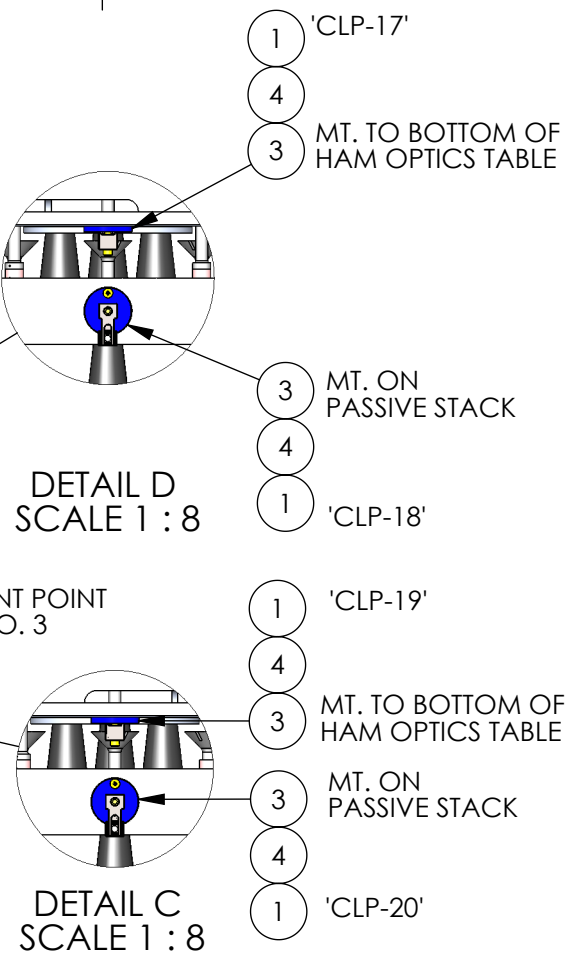
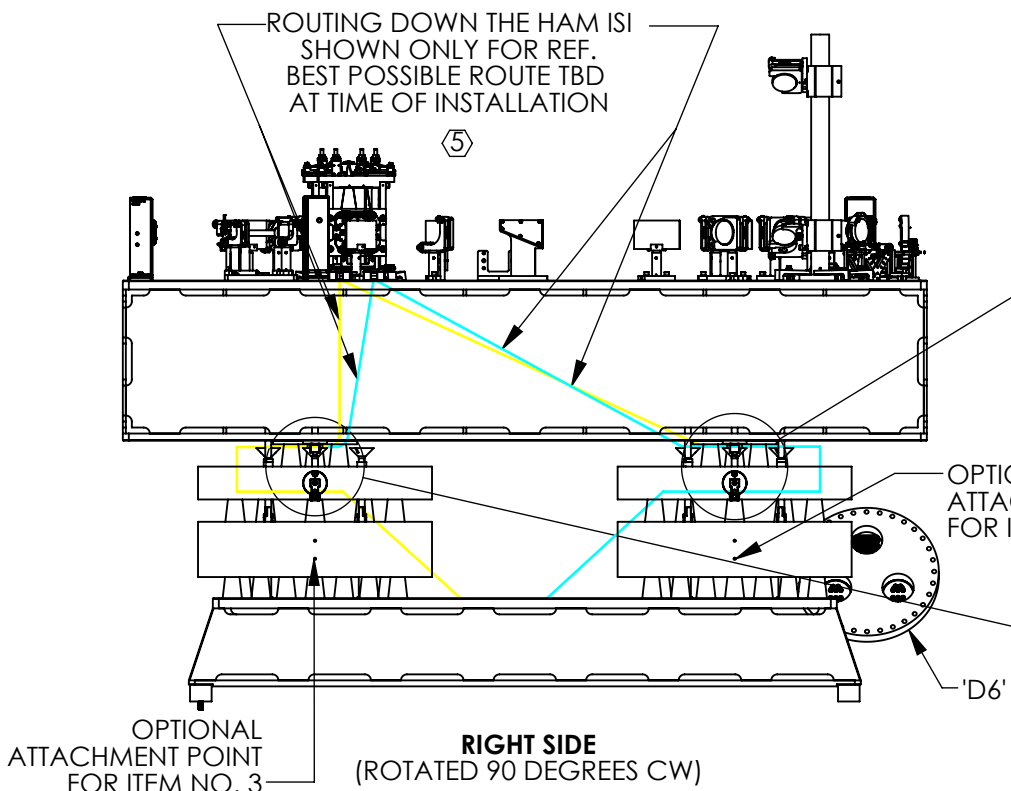

D6\*  
AS VIEWED  
FROM THE AIRSIDE

**LIGO** CALIFORNIA INSTITUTE OF TECHNOLOGY  
MASSACHUSETTS INSTITUTE OF TECHNOLOGY

SIZE	DWG. NO.	REV.
B	D1300075	v4
SCALE: 1:24	PROJECTION:	SHEET 5 OF 12

# ROUTE NO. 5

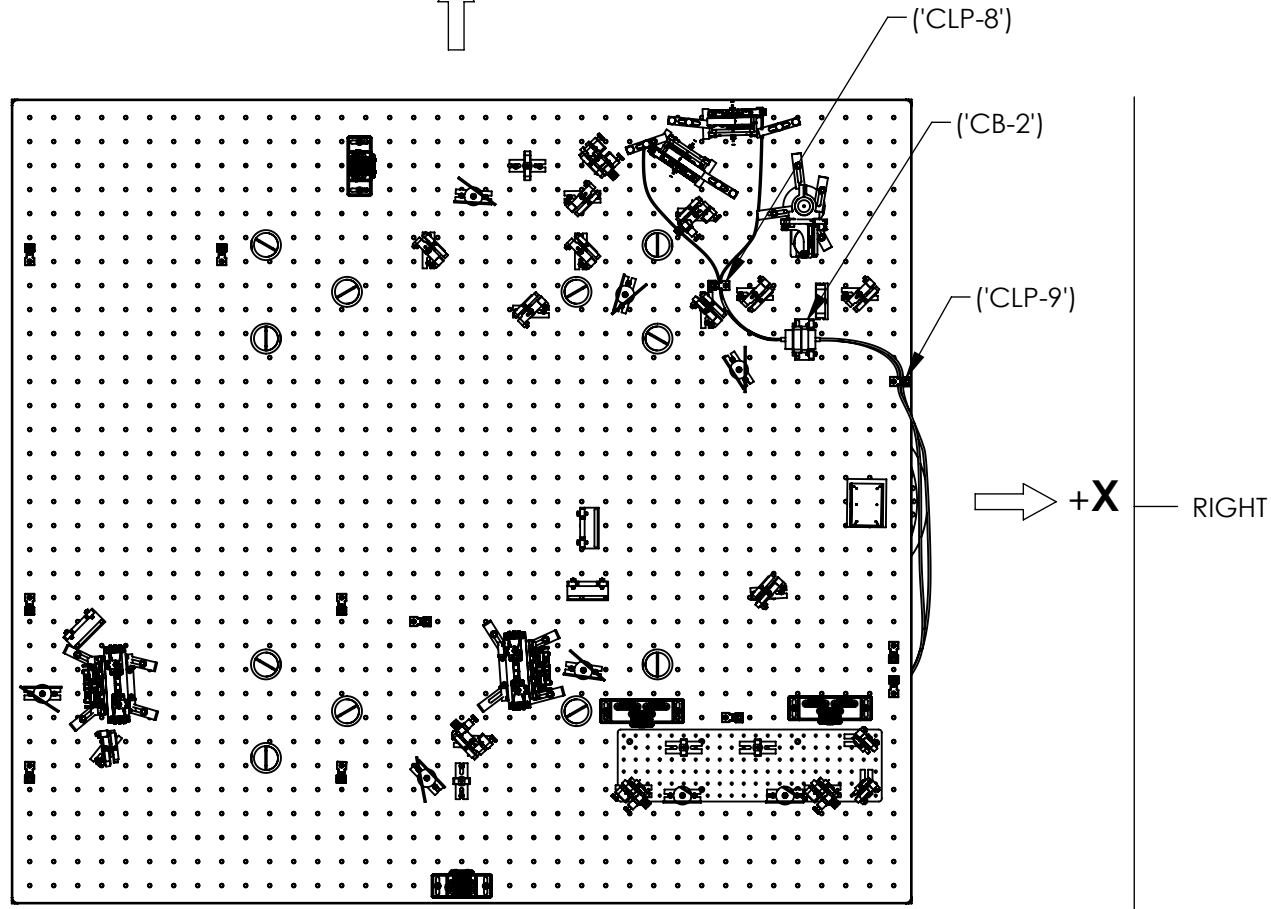

TOP VIEW

⑤ IN-VAC CABLES SHALL BE CLAMPED ON BOTH STAGES OF PROOF MASS BETWEEN THE SPRINGS TO AVOID POTENTIALLY SHORTING THE SEISMIC ISOLATION OF THE HAM STACK. HOWEVER, IF CABLE LENGTH IS NOT LONG ENOUGH THEN ROUTING VIA ONE MASS IS SUFFICIENT. IF THE LATTER IS FOLLOWED, ONE MUST NOTE THIS ON THE DRAWING AND SUPPLY ALT. TO SYSTEMS.

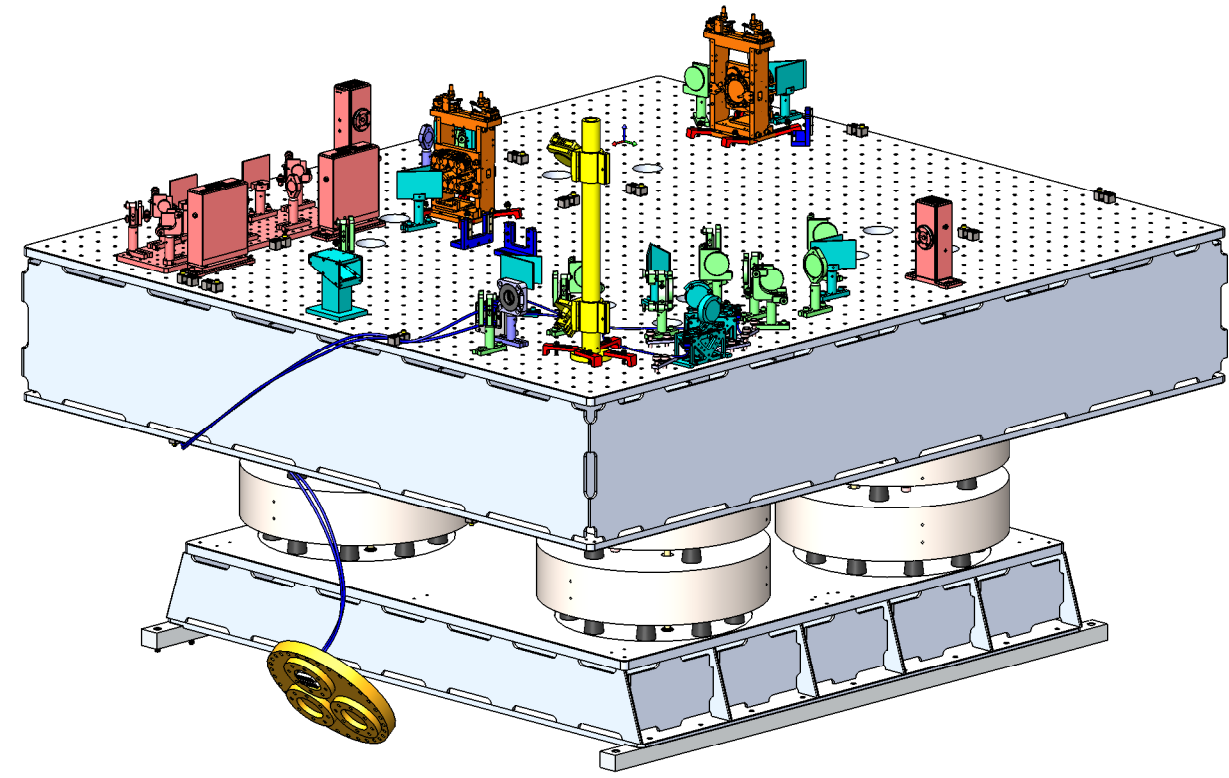

ISO VIEW, REAR-RIGHT

⑤ ROUTING DOWN THE HAM ISI SHOWN ONLY FOR REF. BEST POSSIBLE ROUTE TBD AT TIME OF INSTALLATION

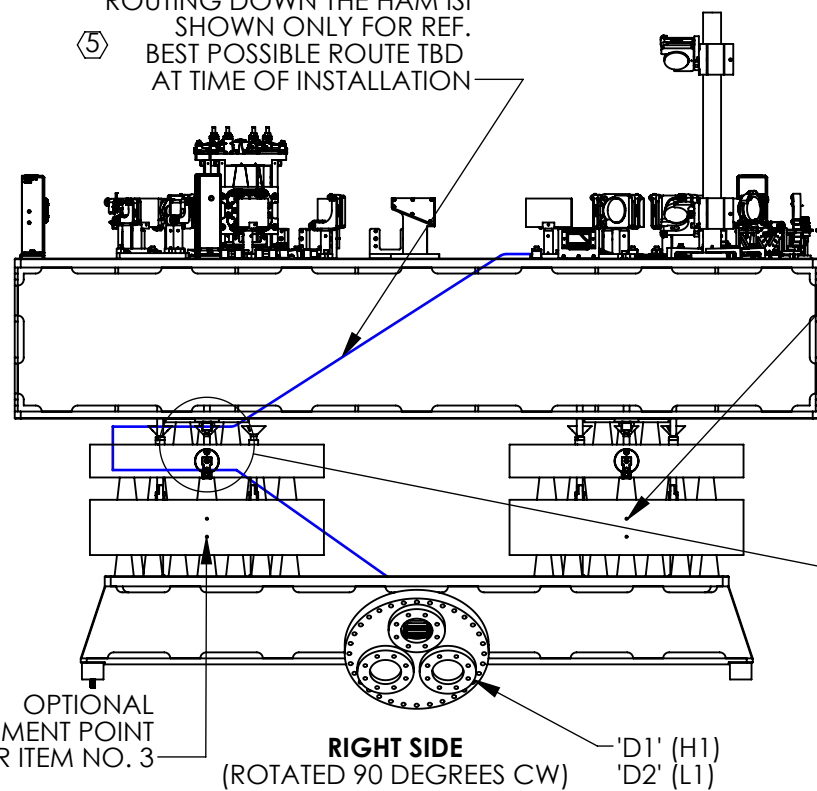

RIGHT SIDE (ROTATED 90 DEGREES CW) 'D1' (H1) 'D2' (L1)

OPTIONAL ATTACHMENT POINT FOR ITEM NO. 3

- ① 'CLP-19'
- ④
- ③ MT. TO BOTTOM OF HAM OPTICS TABLE
- ③ MT. ON PASSIVE STACK
- ④
- ① 'CLP-20'

DETAIL C SCALE 1 : 8

ROUTE NO.5  
SEE TABLE 1 FOR CABLING SPECS.  
(ROUTE CABLE/ CABLES THROUGH REFERENCED CABLE CLAMPS)  
CABLE QTY.: 3

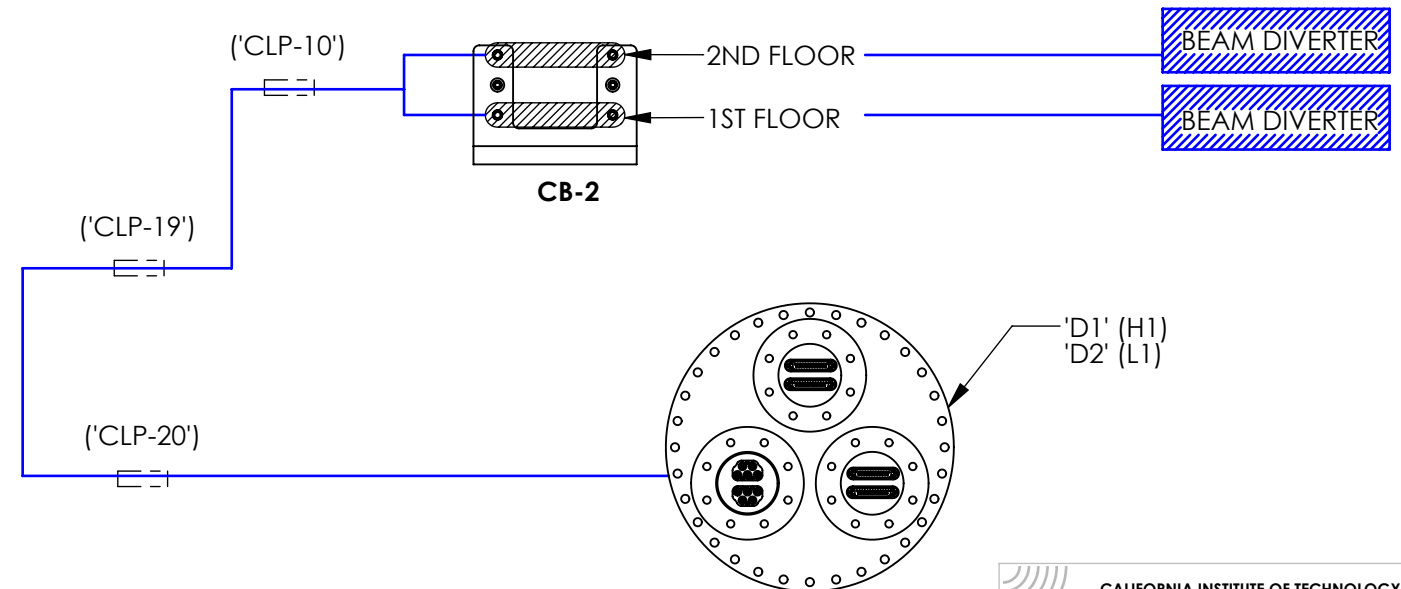

D1\* AS VIEWED FROM THE AIRSIDE

\*SEE D1101775, FOR FLANGE/SUBFLANGE PORT DESIGNATION.

D1300075 - Cable Harness Routing Configuration - HAM1, PART PDM REV: X-006, DRAWING PDM REV: X-004

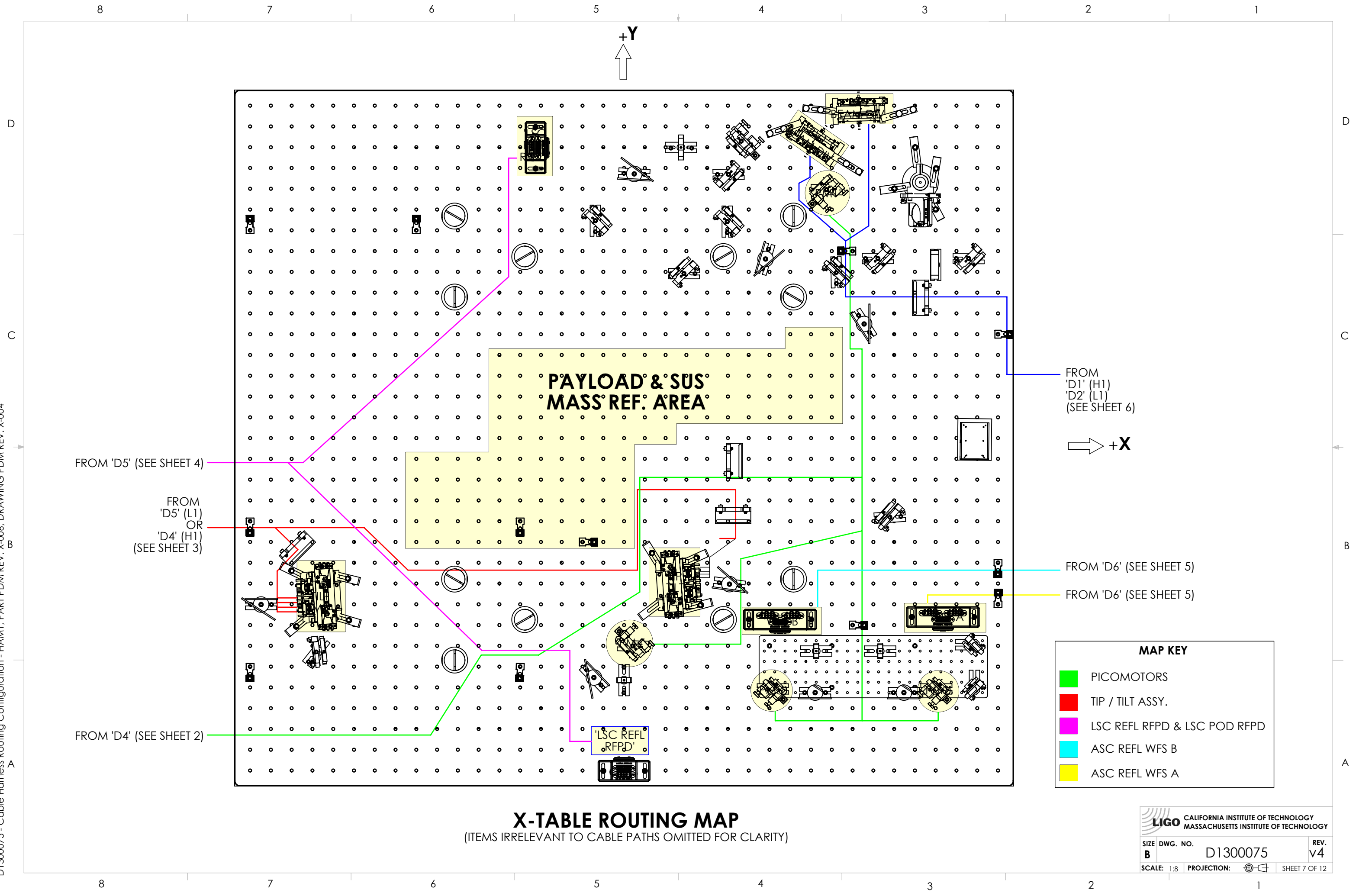

**X-TABLE ROUTING MAP**  
 (ITEMS IRRELEVANT TO CABLE PATHS OMITTED FOR CLARITY)

**MAP KEY**

- PICOMOTORS
- TIP / TILT ASSY.
- LSC REFL RFPD & LSC POD RFPD
- ASC REFL WFS B
- ASC REFL WFS A

**LIGO** CALIFORNIA INSTITUTE OF TECHNOLOGY  
 MASSACHUSETTS INSTITUTE OF TECHNOLOGY

SIZE	DWG. NO.	REV.
B	D1300075	v4
SCALE: 1:8	PROJECTION:	SHEET 7 OF 12

**TABLE 1- HAM 1 CABLING SPECIFICATIONS: ROUTES, BRACKETS DES., SUBSYSTEM AND CABLE DESCRIPTIONS.**

CABLE NO.	CABLE ROUTE	TOTAL CABLE QTY.	CABLE LENGTH (IN)	CABLE NO.	FROM FLANGE DES./PORT	TO ASSIGNED CABLE BRACKET REF.DES.	CABLE BRACKET FLOOR	X-TABLE CABLING SPECS.				CMPNT. REF. DES. (SEE SHEET 7)	DESCRIPTION		
								CABLE NO.	CABLE LENGTH (IN)	FROM	TO				
1	ROUTE NO. 1	1	90/ 120 (H1)	D1000223	D4-1C1	CB-3	1ST	D1000238	36	CB-3 (1ST)	PICOMOTORS	PM	PICOMOTORS		
2	ROUTE NO. 2	2	108	D1000225	D5-3C1 (L1) D4-3C1 (H1)	CB-1	1ST	D1000228	8/5	CB-1 (1ST)	TIP / TILT ASSY.	M3	REFL TIP / TILT ASSY 1		
3				D1000225	D5-3C2 (L1) D4-3C2 (H1)	CB-4	1ST	D1000228	8/5	CB-4 (1ST)	TIP / TILT ASSY.	M4	REFL TIP / TILT ASSY 2		
4	ROUTE NO. 3	2	108	D1000225	D5-1C1	-	-	-	-	-	LSC REFL RFPD	-	-		
5				D1000225	D5-1C2	-	-	-	-	-	-	-	LSC POP RFPD	-	-
6	ROUTE NO. 3	2	106	D1300278	D5-2D1	-	-	-	-	-	LSC REFL RFPD	-	IN VACUUM COAXIAL CABLE ASSY.		
7				D1300278	D5-2D2	-	-	-	-	-	-	-	LSC POP RFPD	-	IN VACUUM COAXIAL CABLE ASSY.
8	ROUTE NO. 4	2	156 / 180 (H1)	D1000225	D6-1C1	-	-	-	-	-	ASC REFL A WFS	'WFS A'	-		
9				D1000225	D6-1C2	-	-	-	-	-	-	-	ASC REFL B WFS	'WFS B'	-
10	ROUTE NO. 4	4	156	D1300278	D6-2D1	-	-	-	-	-	ASC REFL A WFS	'WFS A'	IN VACUUM COAXIAL CABLE ASSY.		
11				D1300278	D6-2D2	-	-	-	-	-	-	-	ASC REFL A WFS	'WFS A'	IN VACUUM COAXIAL CABLE ASSY.
12				D1300278	D6-3D1	-	-	-	-	-	-	-	ASC REFL B WFS	'WFS B'	IN VACUUM COAXIAL CABLE ASSY.
13				D1300278	D6-3D2	-	-	-	-	-	-	-	ASC REFL B WFS	'WFS B'	IN VACUUM COAXIAL CABLE ASSY.
14	ROUTE NO. 5	2	110 / 216 (H1)	D1000223	D2-1C1 (L1) D1-1C1 (H1)	CB-2	1ST	D1000237	36	CB-2 (1ST)	BEAM DIVERTER	'BV2'	REFL IN-VAC BEAM BLOCKER		
15				D1000223	D2-1C2 (L1) D1-1C2 (H1)	CB-2	2ND	D1000237	36	CB-2 (2ND)	BEAM DIVERTER	'BV1'	POP IN-VAC BEAM BLOCKER		

FOR INTERCONNECT CABLING DIAGRAM, SEE SHEETS 9 - 12

CABLE COUNT (SUPPLIED FOR REF. ONLY)	
CABLE DCC NO.	QTY. NEEDED
D1000223	3
D1000225	6
D1000228	2
D1000237	2
D1000238	1
D1300278-106	2
D1300278-156	4

SEE E1100730 FOR DETAILED IN-VACUUM CABLE DATA (i.e.: STATUS AND AVAILABILITY)

④ INDICATED ITEMS ROUTED DIRECTLY FROM FLANGE TO DEVICE & SECURED W/ CABLE CLAMPS.

**LIGO** CALIFORNIA INSTITUTE OF TECHNOLOGY  
MASSACHUSETTS INSTITUTE OF TECHNOLOGY

SIZE DWG. NO. **B** D1300075 REV. **v4**

SCALE: 1:24 PROJECTION: SHEET 8 OF 12

D1300075 - Cable Harness Routing Configuration - HAM1, PART PDM REV: X-006, DRAWING PDM REV: X-004



D1300075 - Cable Harness Routing Configuration - HAM1, PART PDM REV: X-006, DRAWING PDM REV: X-004

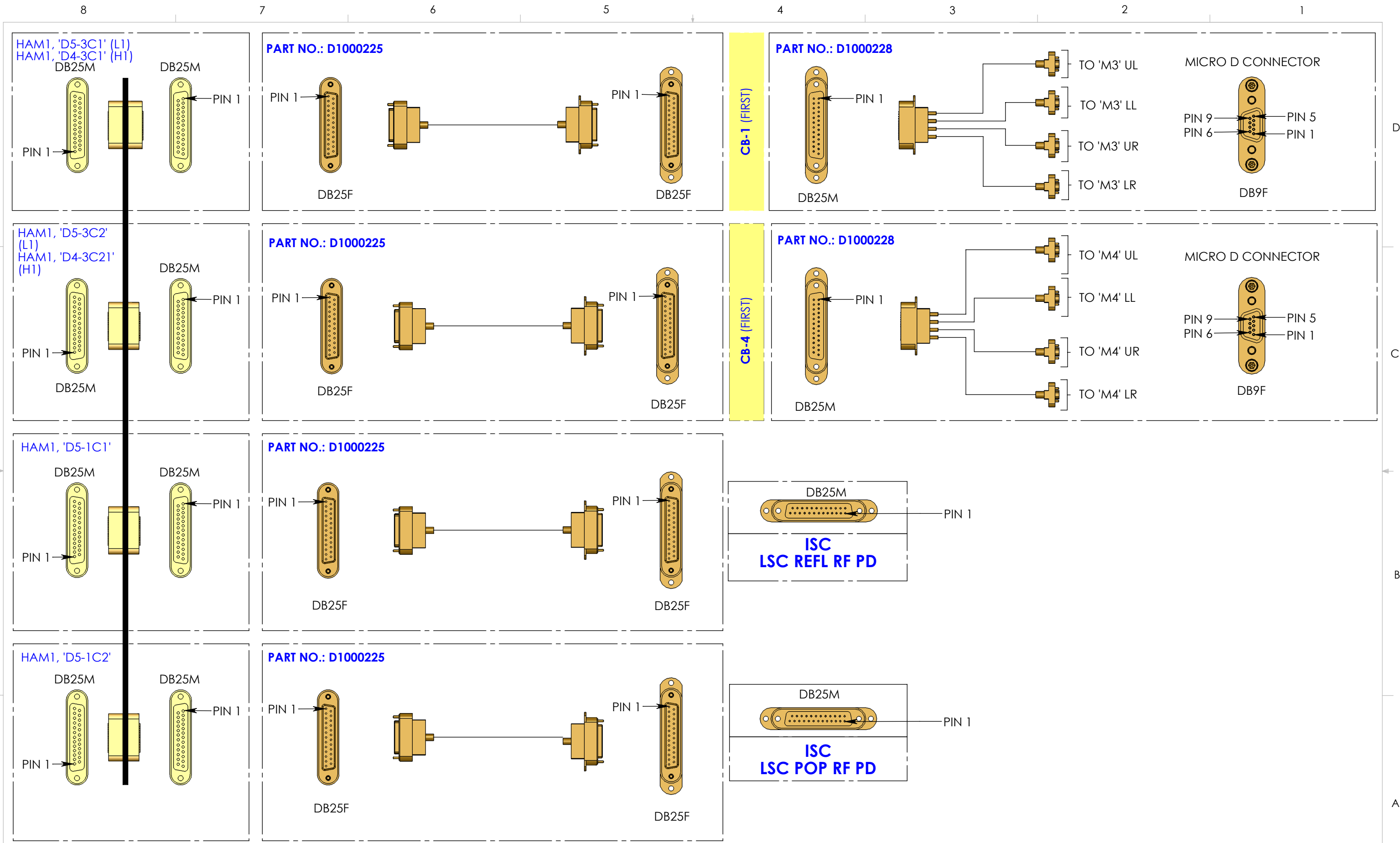

**HAM1, INTERCONNECT CABLING DIAGRAM**  
(CONTINUED ON SHEET 10)

PART NO. & REF. DES. SHOWN ARE FOR REFERENCE ONLY, AND DO NOT APPEAR ON CABLE ASSEMBLIES.

CALIFORNIA INSTITUTE OF TECHNOLOGY MASSACHUSETTS INSTITUTE OF TECHNOLOGY	
SIZE DWG. NO.	REV.
B D1300075	v4
SCALE: 1:4 PROJECTION:	SHEET 9 OF 12

D1300075 - Cable Harness Routing Configuration - HAM1, PART PDM REV: X-006, DRAWING PDM REV: X-004

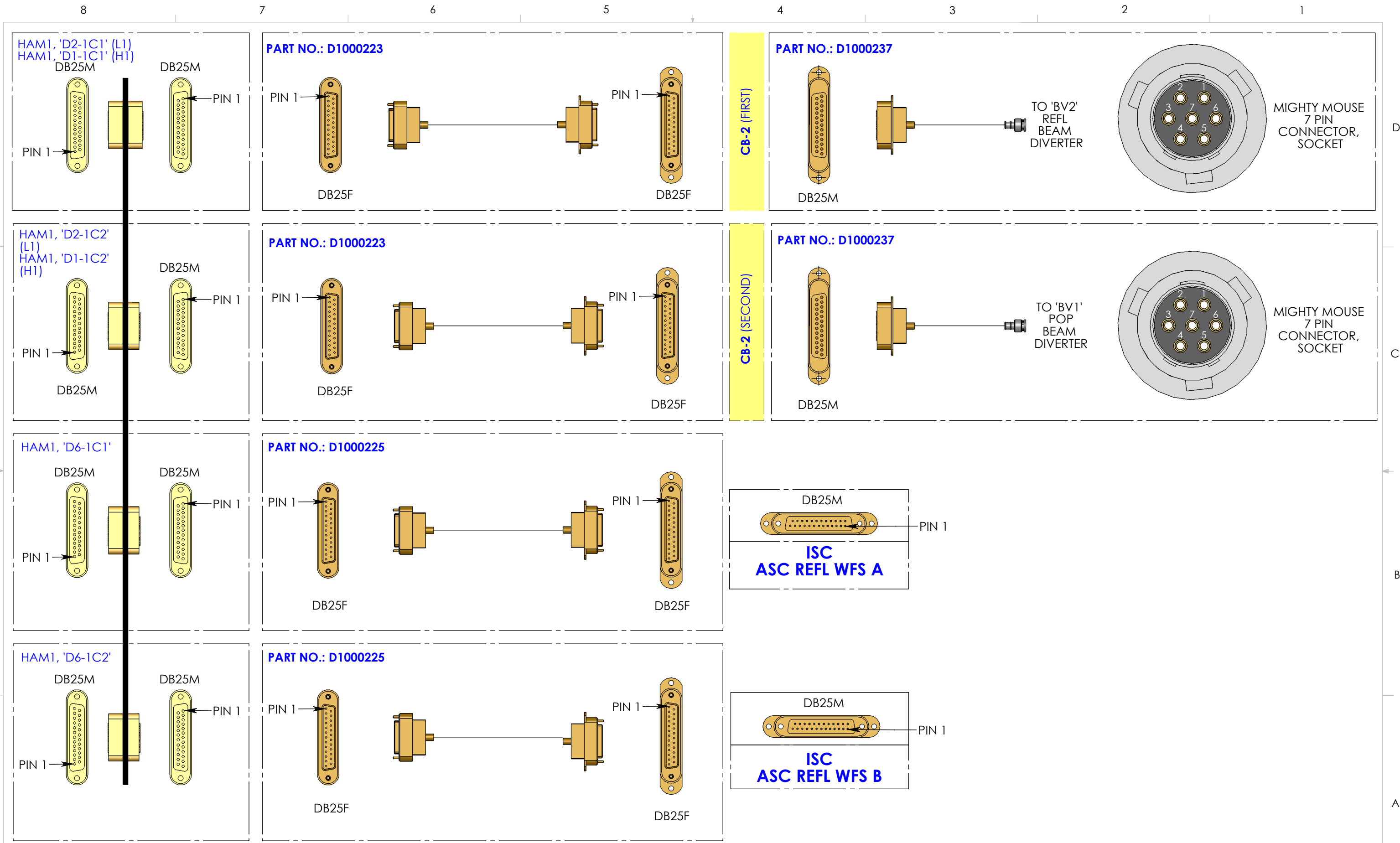

**HAM1, INTERCONNECT CABLING DIAGRAM**  
(CONTINUED ON SHEET 11)

PART NO. & REF. DES. SHOWN ARE FOR REFERENCE ONLY, AND DO NOT APPEAR ON CABLE ASSEMBLIES.

CALIFORNIA INSTITUTE OF TECHNOLOGY MASSACHUSETTS INSTITUTE OF TECHNOLOGY	
SIZE DWG. NO.	REV.
B D1300075	v4
SCALE: 1:4	PROJECTION:
SHEET 10 OF 12	

D1300075 - Cable Harness Routing Configuration - HAM1, PART PDM REV: X-006, DRAWING PDM REV: X-004

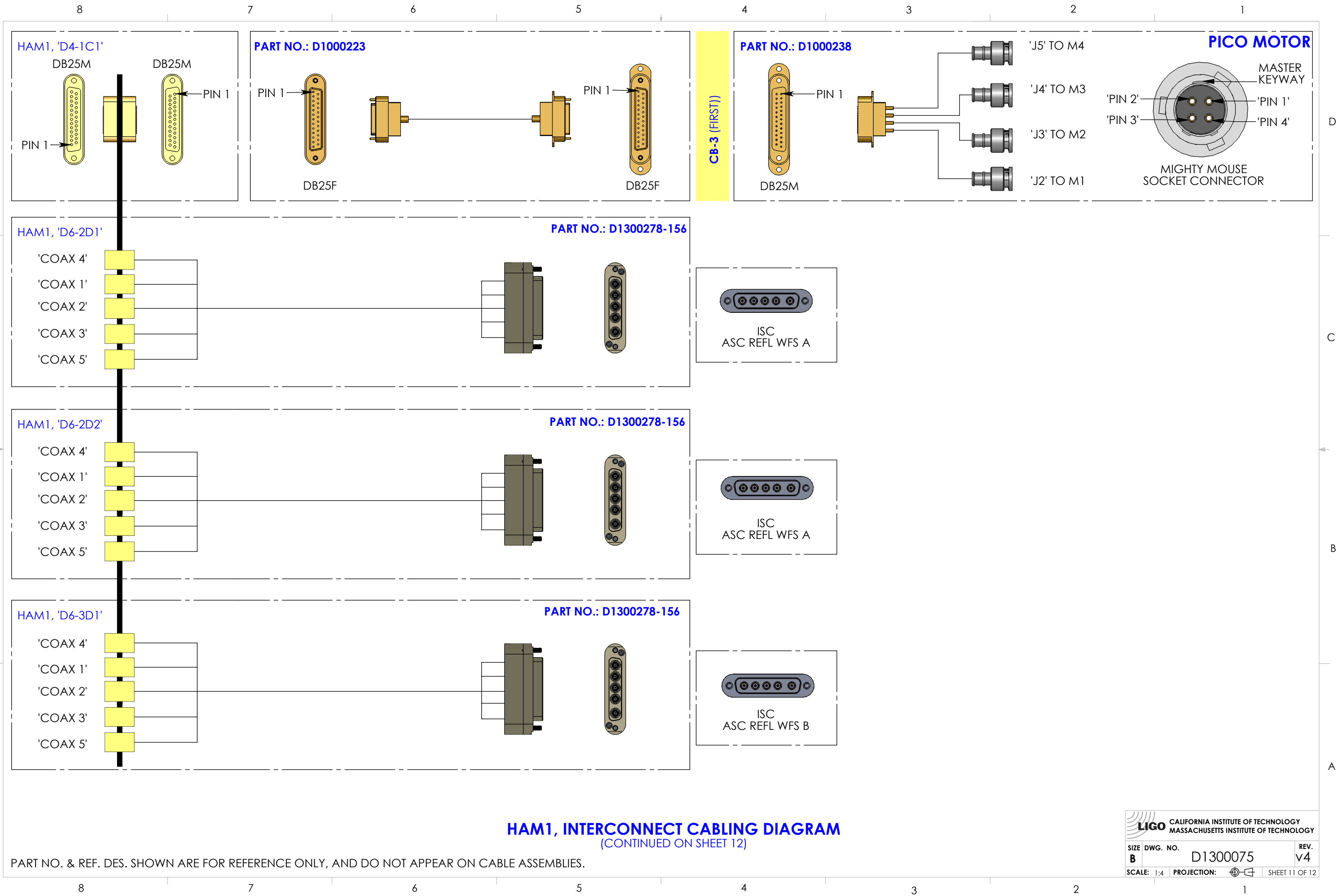

**HAM1, INTERCONNECT CABLING DIAGRAM**  
(CONTINUED ON SHEET 12)

PART NO. & REF. DES. SHOWN ARE FOR REFERENCE ONLY, AND DO NOT APPEAR ON CABLE ASSEMBLIES.

CALIFORNIA INSTITUTE OF TECHNOLOGY MASSACHUSETTS INSTITUTE OF TECHNOLOGY	
SIZE DWG. NO. <b>B</b> D1300075	REV. <b>v4</b>
SCALE: 1:4 PROJECTION:	SHEET 11 OF 12

D1300075 - Cable Harness Routing Configuration - HAM1, PART PDM REV: X-006, DRAWING PDM REV: X-004

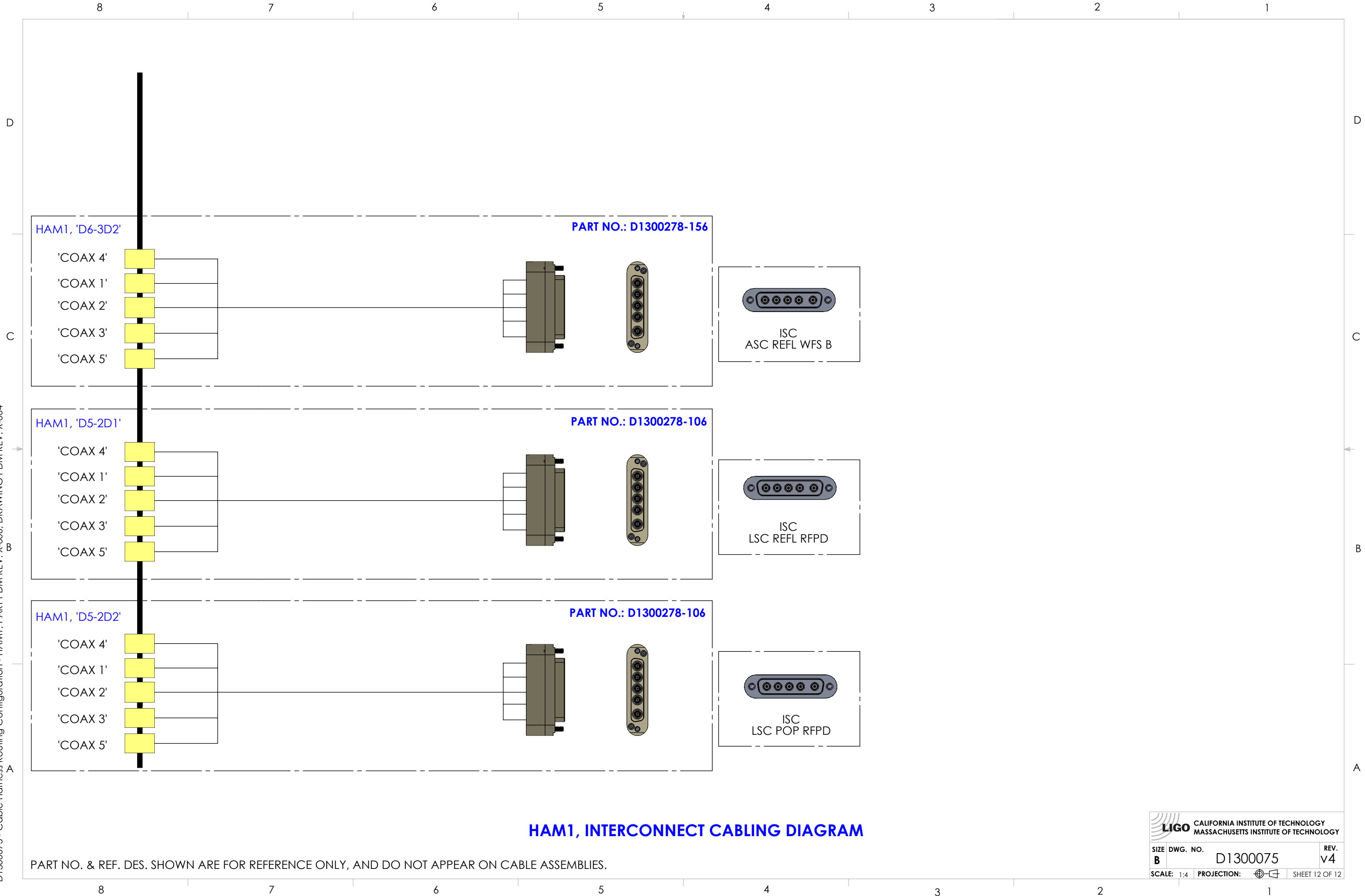

### HAM1, INTERCONNECT CABLING DIAGRAM

PART NO. & REF. DES. SHOWN ARE FOR REFERENCE ONLY, AND DO NOT APPEAR ON CABLE ASSEMBLIES.

 CALIFORNIA INSTITUTE OF TECHNOLOGY MASSACHUSETTS INSTITUTE OF TECHNOLOGY	
SIZE <b>B</b>	DWG. NO. D1300075
SCALE: 1:4	PROJECTION:  SHEET 12 OF 12
REV. v4	