

*LIGO Laboratory / LIGO Scientific Collaboration*

LIGO- E1300056-v4

*LIGO*

5/23/2013

---

Output Faraday Isolator Installation and Final Alignment  
Procedure

---

Mike Smith

Distribution of this document:  
LIGO Scientific Collaboration

This is an internal working note  
of the LIGO Laboratory.

**California Institute of Technology**  
**LIGO Project – MS 18-34**  
**1200 E. California Blvd.**  
**Pasadena, CA 91125**  
Phone (626) 395-2129  
Fax (626) 304-9834  
E-mail: info@ligo.caltech.edu

**Massachusetts Institute of Technology**  
**LIGO Project – NW22-295**  
**185 Albany St**  
**Cambridge, MA 02139**  
Phone (617) 253-4824  
Fax (617) 253-7014  
E-mail: info@ligo.mit.edu

**LIGO Hanford Observatory**  
**P.O. Box 159**  
**Richland WA 99352**  
Phone 509-372-8106  
Fax 509-372-8137

**LIGO Livingston Observatory**  
**P.O. Box 940**  
**Livingston, LA 70754**  
Phone 225-686-3100  
Fax 225-686-7189

<http://www.ligo.caltech.edu/>

## Table of Contents

<b>1</b>	<b>Introduction.....</b>	<b>4</b>
<b>2</b>	<b>OFI Assembly.....</b>	<b>4</b>
<b>2.1</b>	<b>Overview of the D0900136 OFI Assembly .....</b>	<b>4</b>
<b>3</b>	<b>OFI Installation onto HAM5.....</b>	<b>4</b>
<b>3.1</b>	<b>Preparation of OFI and HAM5.....</b>	<b>4</b>
3.1.1	Attachment OFI Spacer .....	4
3.1.2	Attaching Transport Brackets and Locking Shims .....	7
3.1.3	Placement of AOS-FI Pre-Installation Plate D1200047 on HAM5 Optical Table.....	8
<b>3.2</b>	<b>Transport of OFI.....</b>	<b>9</b>
3.2.1	Mounting onto Genie Lift .....	9
<b>3.3</b>	<b>Insertion of OFI with Spacer into HAM Chamber .....</b>	<b>10</b>
3.3.1	Preparation .....	10
3.3.2	HAM Door Installation Arm.....	11
3.3.3	OFI Mate to Template.....	11
3.3.4	Placement of Mover Tooling .....	12
<b>4</b>	<b>OFI Optical Alignment in HAM5 .....</b>	<b>13</b>
<b>4.1</b>	<b>Equipment List .....</b>	<b>14</b>
<b>4.2</b>	<b>Optical Alignment Procedure .....</b>	<b>14</b>
4.2.1	Preparation .....	14
4.2.2	Horizontal Alignment .....	16
4.2.3	Vertical Alignment .....	17
4.2.4	OFI Damper Holder Height Alignment .....	20
4.2.5	Nominal Height of OFI above HAM5 Table.....	22

## Table of Contents

<i>Table 1: Nominal Height of IFO Beam at OFI.....</i>	<i>22</i>
--	-----------

## Table of Figures

Figure 1: Spacer attached to Bottom of OFI Weldment ..... 6  
 Figure 2: OFI Structure in Transport State..... 7  
 Figure 3: Pre-Installation Plate on HAM5 Optical Table ..... 8  
 Figure 4: OFI on Genie Lift Ready for Transport to HAM ..... 9  
 Figure 5: Locking Transport Shim ..... 10  
 Figure 6: OFI mounted to Installation Arm ..... 11  
 Figure 7: OFI mated to Pre-Installation Plate..... 12  
 Figure 8: Placement of Mover Tooling ..... 13  
 Figure 9: OFI Assembly on HAM Table with Dog Clamps and BS Movers ..... 16  
 Figure 10: Vertical Height Adjustment ..... 18  
 Figure 11: Guitar Tuner to set Wire Tension ..... 19  
 Figure 12: Earthquake Stop Posts Centered within Crossbar Plate..... 20  
 Figure 13: Use the Damper Plate Height Gauge to verify that the Damper Holder Assy bracket is 0.515 in above the Optics Table ..... 21

### CHANGE LOG

Date, version	Summary of Changes
V2 4/9/13	<ul style="list-style-type: none"> <li>• Update installation drawings</li> </ul>
V3 5/17/13	<ul style="list-style-type: none"> <li>• Add sec 4.2.5</li> <li>• Add dog clamp detail</li> <li>• Added hazard analysis reference</li> </ul>
V4 5/23/13	<ul style="list-style-type: none"> <li>• Add sec 4.2.5 Height Table</li> <li>• Add Earthquake Stop Post D1300136, update Figure 12</li> <li>• Added OFI beam heights</li> </ul>

## 1 Introduction

This document details the installation procedure for the AOS Faraday Isolator (OFI) Assembly, D0900136. The OFI is one element of the Stray Light Control (SLC) subsystem.

The OFI will be installed in HAM5 chamber under Class A clean room standards: for a clean assembly all LIGO standards should be followed, as presented in the latest version of the **LIGO Contamination Control Plan (E0900047)**. Clean room garb including UHV gloves should be worn when working with parts. All tools that come in contact with the OFI assembly will be cleaned to class B standards.

Refer to [E1300283-v1 OFI Hazard Analysis](#) before beginning the installation procedure.

These procedures must be read before beginning the installation and final alignment of the OFI.

## 2 OFI Assembly

### 2.1 Overview of the D0900136 OFI Assembly

The OFI is comprised of the following sub-assemblies, as shown in **Error! Reference source not found.**

D0900048 DAMPER HOLDER ASSEMBLY

D0900623 FARADAY ISOLATOR TABLE ASSY

D0900586 UPPER WIRE ASSY

D0900170 EARTHQUAKE CROSSBAR ASSY

D1002256 EARTHQUAKE CROSSBAR\_IN ASSY

D0900579 BLADE GUARD ASSY

D0900655 STRUCTURAL WELDMENT ASSY, OMC

## 3 OFI Installation onto HAM5

### 3.1 Preparation of OFI and HAM5

#### 3.1.1 Attachment OFI Spacer

Equipment List:

- ¼-20x 1.00 SHCS
- Flat washer 0.25

Attach the OFI Spacer to the bottom of the OFI Weldment with ¼-20 SHCS and flat washers before the OFI is placed in the HAM chamber--D1100208 Spacer for HAM5 LLO IFO, D1100171 Spacer for HAM5 LHO IFO.

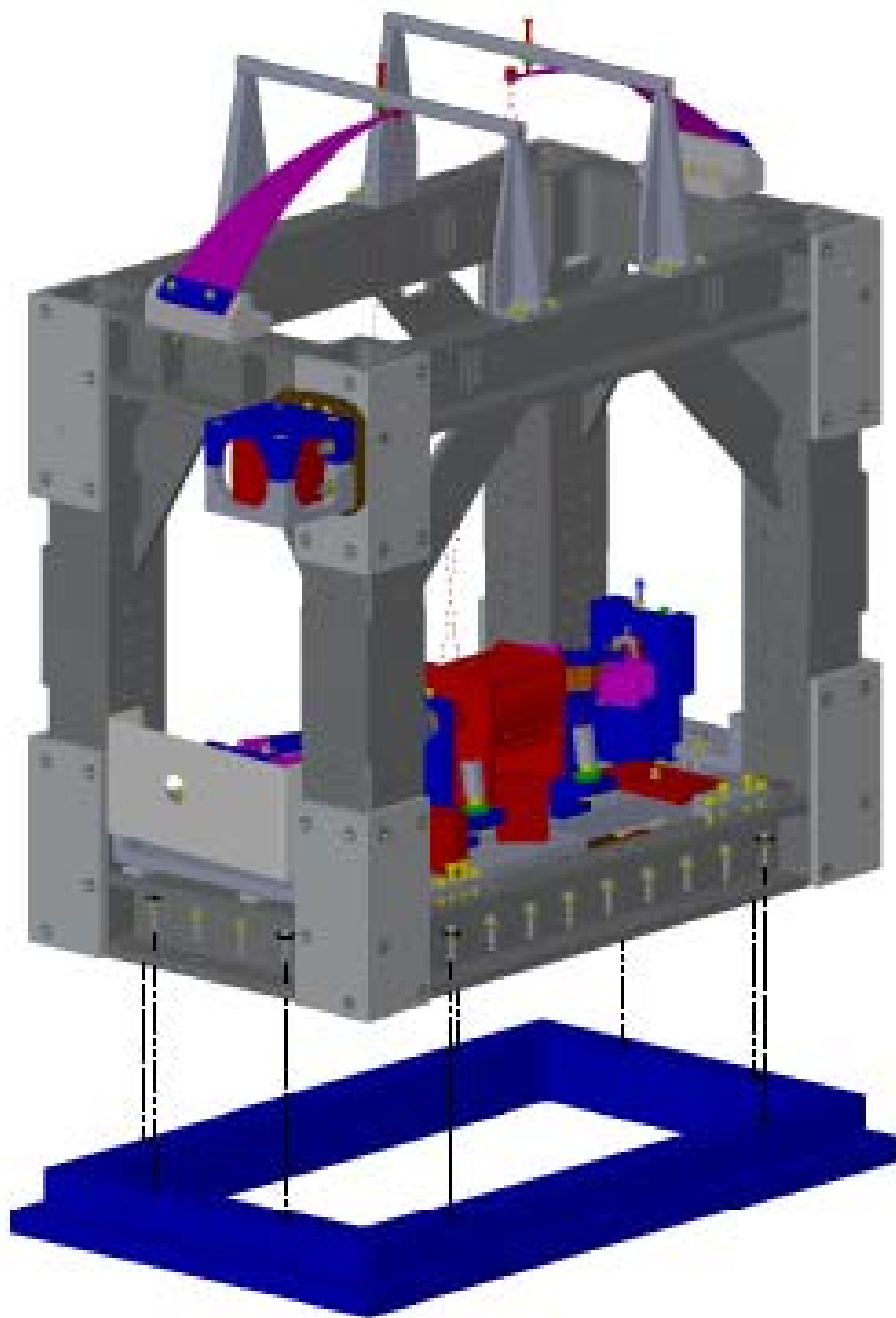

① INSTALLATION ASSEMBLY  
OF I AND SPACER

**Figure 1: Spacer attached to Bottom of OFI Weldment**

### 3.1.2 Attaching Transport Brackets and Locking Shims

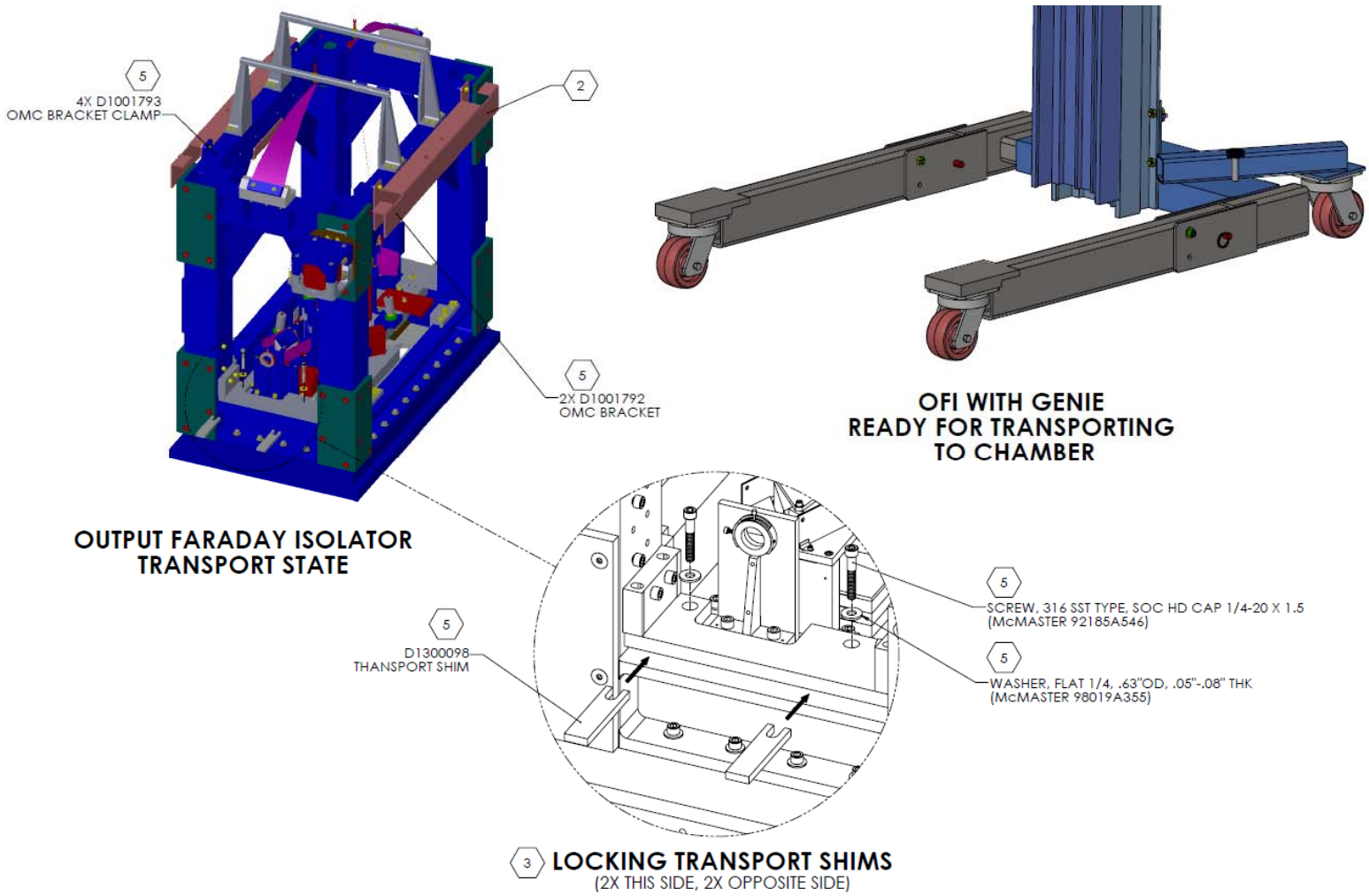

Figure 2: OFI Structure in Transport State

### 3.1.3 Placement of AOS-FI Pre-Installation Plate D1200047 on HAM5 Optical Table

Mount the AOS-FI Pre-Installation Plate on the HAM5 ISI table, at the location shown in D0900527.

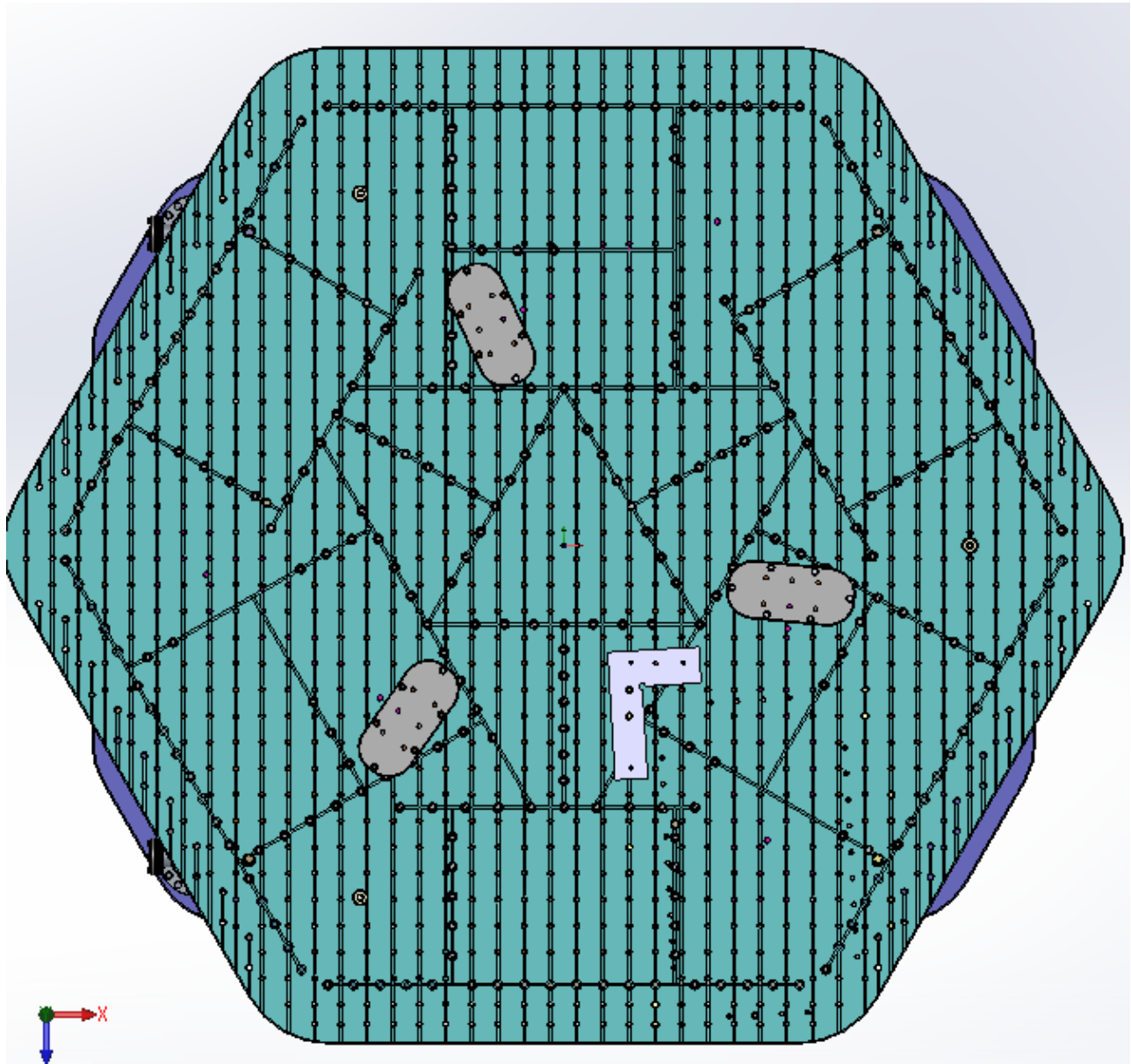

Figure 3: Pre-Installation Plate on HAM5 Optical Table



## 3.2 Transport of OFI

### 3.2.1 Mounting onto Genie Lift

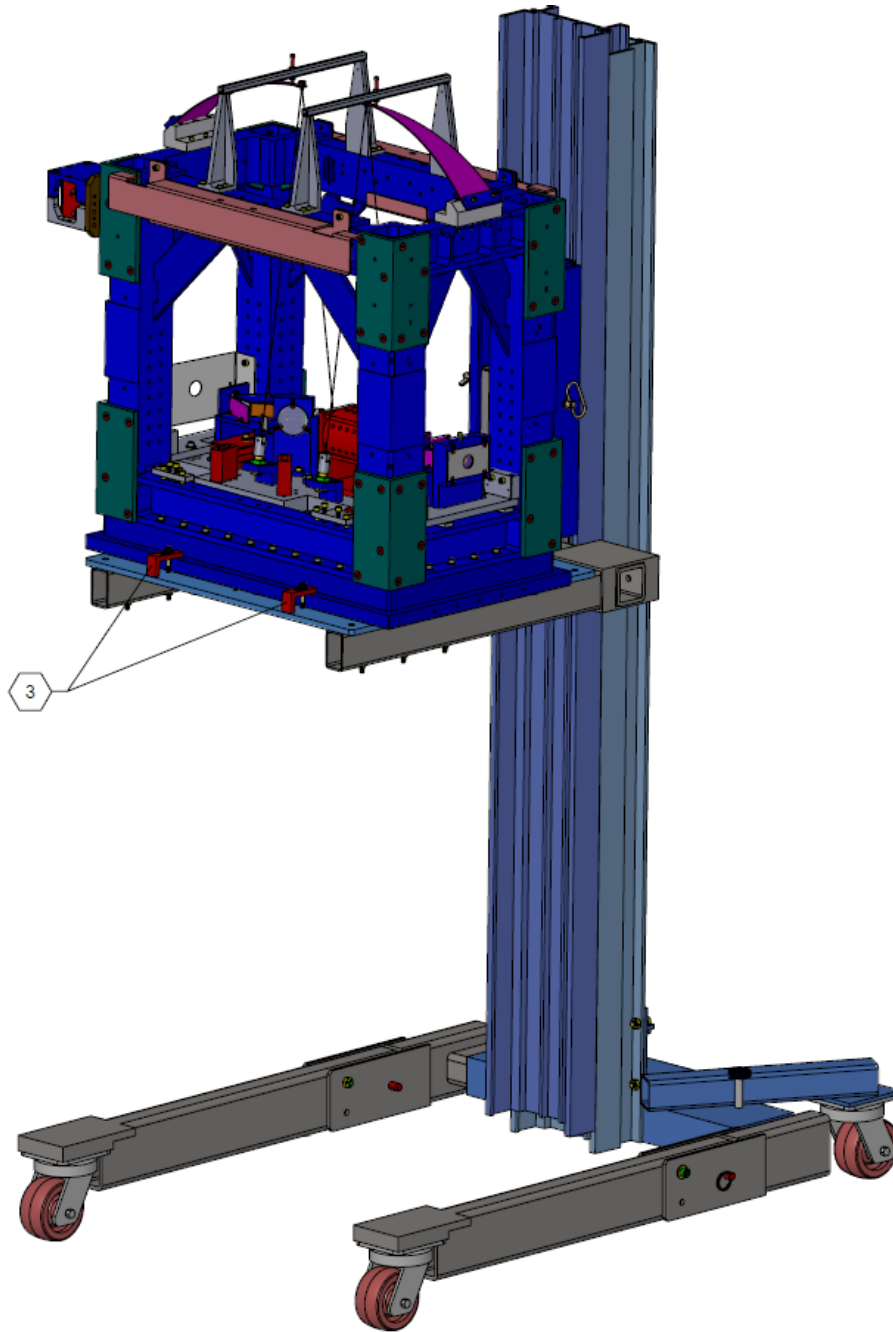

Figure 4: OFI on Genie Lift Ready for Transport to HAM

### 3.3 Insertion of OFI with Spacer into HAM Chamber

Equipment List:

- Quad BS Mover Assemblies D1100018

#### 3.3.1 Preparation

- Teflon Highway on HAM5 Optical Table

Place a thin sheet of Teflon on the HAM5 Optical table; the Teflon should extend from the location where the OFI will be placed with the Installation Arm to the final footprint of the OFI, so that the OFI can be dragged across the Teflon sheet to its final position.

- Transport Shim

Verify that the OFI suspended optical table is locked to the Crossbar Plate D0900170 by sandwiching the Transport Shim Down D1200098 between them and locking with the 0.25-20 x 1.5 SHCS and washer.

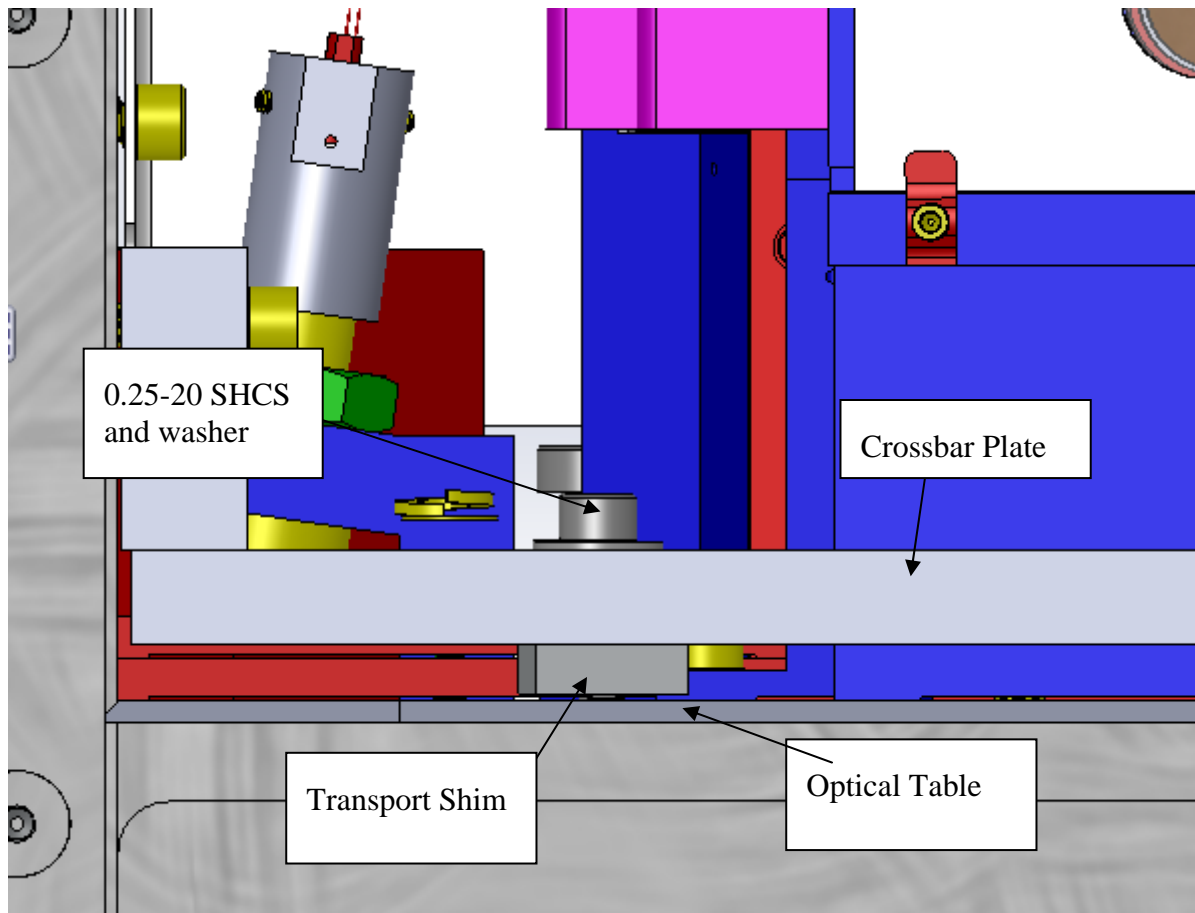

**Figure 5: Locking Transport Shim**

- Prepare the Genie Lift
- Two Persons will lift the OFI onto the prepared Genie Lift.
- Transport the OFI by means of the Genie Lift to the open door of HAM5
- Two persons will lift the OFI off of the Genie Lift and place it onto the HAM Door Installation Arm.

### 3.3.2 HAM Door Installation Arm

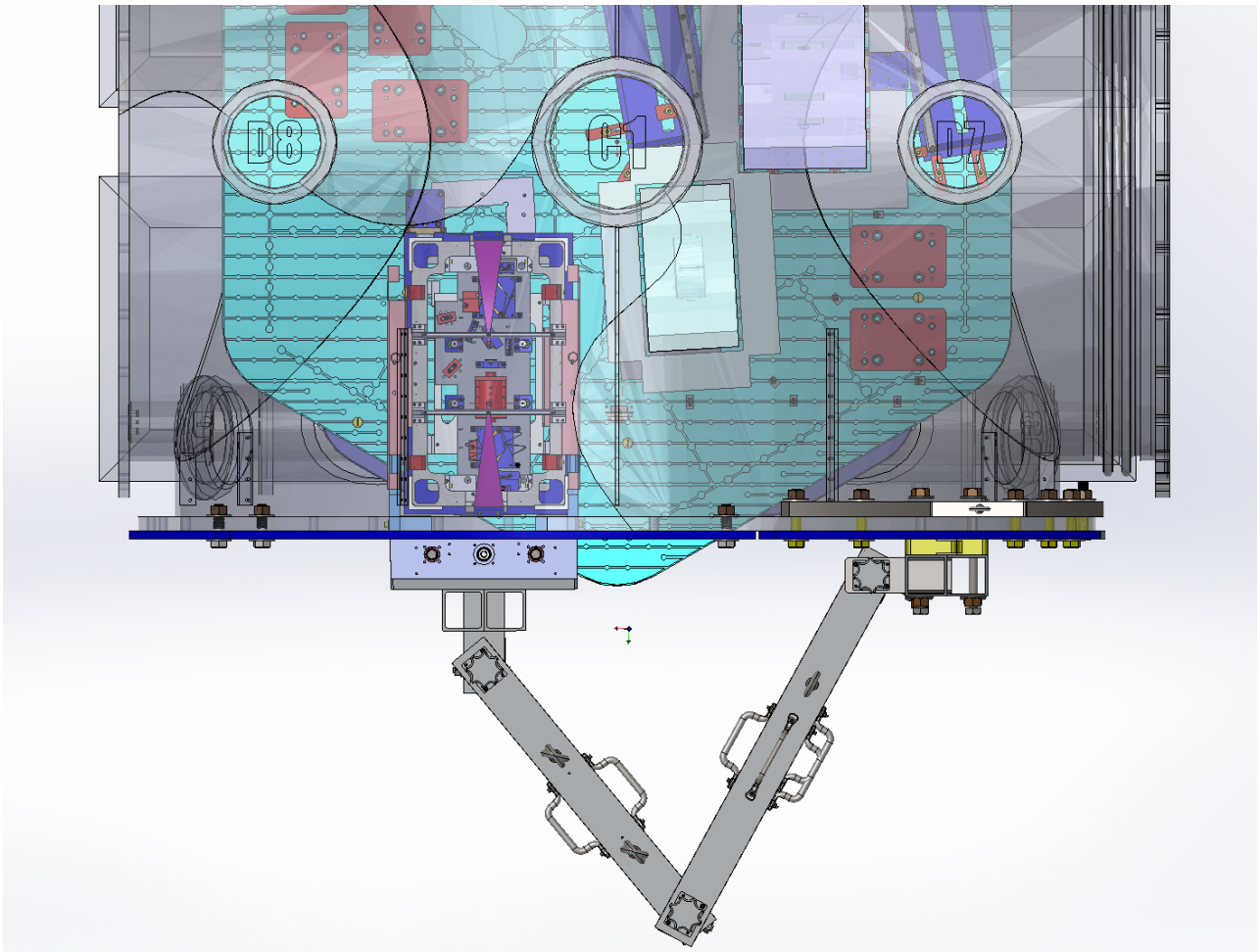
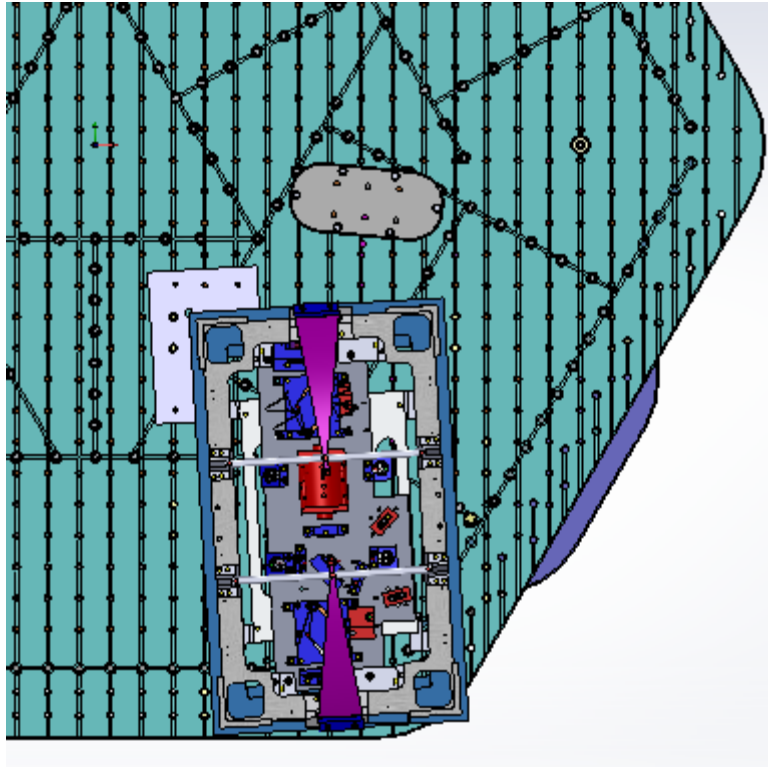

**Figure 6: OFI mounted to Installation Arm**

- Use the Installation Arm to place the OFI onto the Teflon sheet.
- Retract the Installation Arm

### 3.3.3 OFI Mate to Template

- Slide the OFI across the Teflon sheet and orient the forward left-hand corner of the OFI Spacer into the corner of the AOS-FI Pre-Installation Plate D1200047.

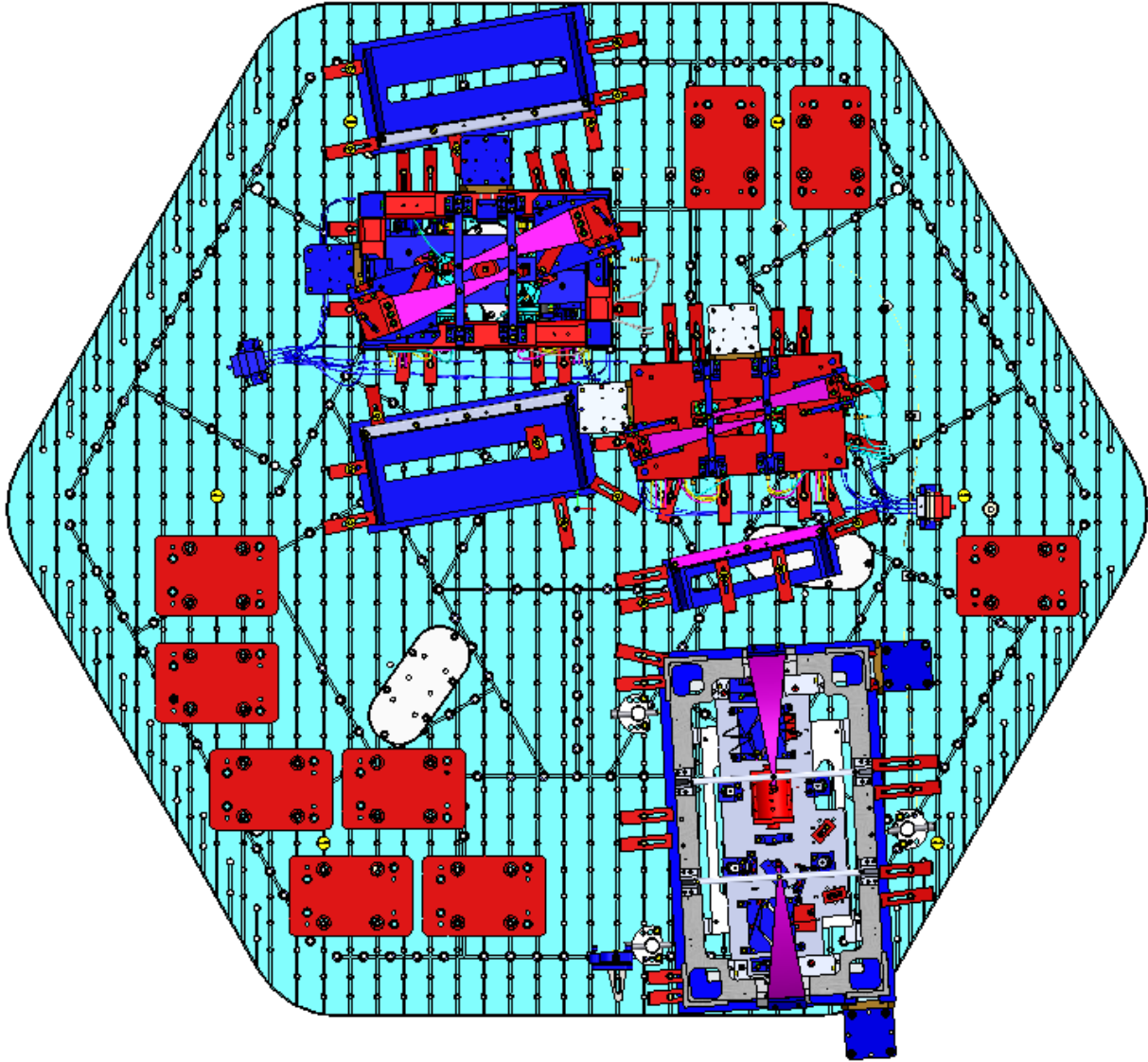

**Figure 7: OFI mated to Pre-Installation Plate**

- Pull the Teflon sheet from under the OFI Spacer and remove from the HAM.
- Remove the AOS-FI Pre-Installation Plate clamp the OFI Spacer temporarily with dog clamps until the OFI Final Alignment procedure commences.

### 3.3.4 Placement of Mover Tooling

- Place two Quad BS Mover Assemblies D1100018 on the inboard side of the OFI, and a third Quad BS Mover Assembly on the outboard side.
- Loosen the Dog Clamps so that the OFI is free to move laterally to the OFI beam direction that will transmit through PRM.



**Figure 8: Placement of Mover Tooling**

#### **4 OFI Optical Alignment in HAM5**

The OFI final optical alignment in HAM5 assumes that the Preliminary Optical alignment is complete (see E1201074-v2 Advanced LIGO Output Faraday Isolator Assembly and Alignment Procedure).

### 4.1 Equipment List

- 1) Input Alignment Aperture, Diaphragm D20S OFI
- 2) Output Alignment Aperture, Diaphragm D20S OFI
- 3) IR fluorescent sensor card
- 4) Pliers
- 5) wrench

### 4.2 Optical Alignment Procedure

#### 4.2.1 Preparation

- Prepare the PSL laser to flash and provide an aligned beam transmitted through the SRM mirror.
- Install the Input Alignment Aperture and Output Alignment Aperture
- Release and remove the Transport Shims so that the OFI Table hangs freely
- Install the Earthquake Stop Post D1300136 to the four corners of the optics table

See [D0900527](#) AdvLIGO SUS HAM5-L1, XYZ Local CS for AOS OFI

10	D0900136	FARADAY ISOLATOR ASSEMBLY	--	1
9	D1001376-03	AdvLIGO HAM Optics Table Dog Clamp 1.1L	304 SSSL	2
8	98017A660	Washer, Flat. 1/4 size, .5" OD, .057-.069 Thk		26
7	C-2016-N	Screw, Soc HD Cap, 1/4-20 x 1.00, 18-8 Stainless Steel	Material <not specified>	26
6	D1201149	AdvLIGO AOS Output Faraday Isolator Spacer Assembly	N/A	1
5	D1001376-01	AdvLIGO HAM Optics Table Dog Clamp 1.1S	304 SSSL	4
4	D1001376-02	AdvLIGO HAM Optics Table Dog Clamp 1.1M	304 SSSL	6
4	TWP450-2032-N	SCREW, 12PT, 450, 1/4-20X2" (UC COMP)	450 SSSL	12
2	D1100785-530	WASHER, FLAT, .25 X .530 O.D.	NITRONIC 60	12
1	D1000846	Vibration Absorber Assembly	N/A	2
<b>ITEM NO.</b>	<b>PART NUMBER</b>	<b>DESCRIPTION</b>	<b>MATERIAL</b>	<b>REQ</b>

PARTS LIST



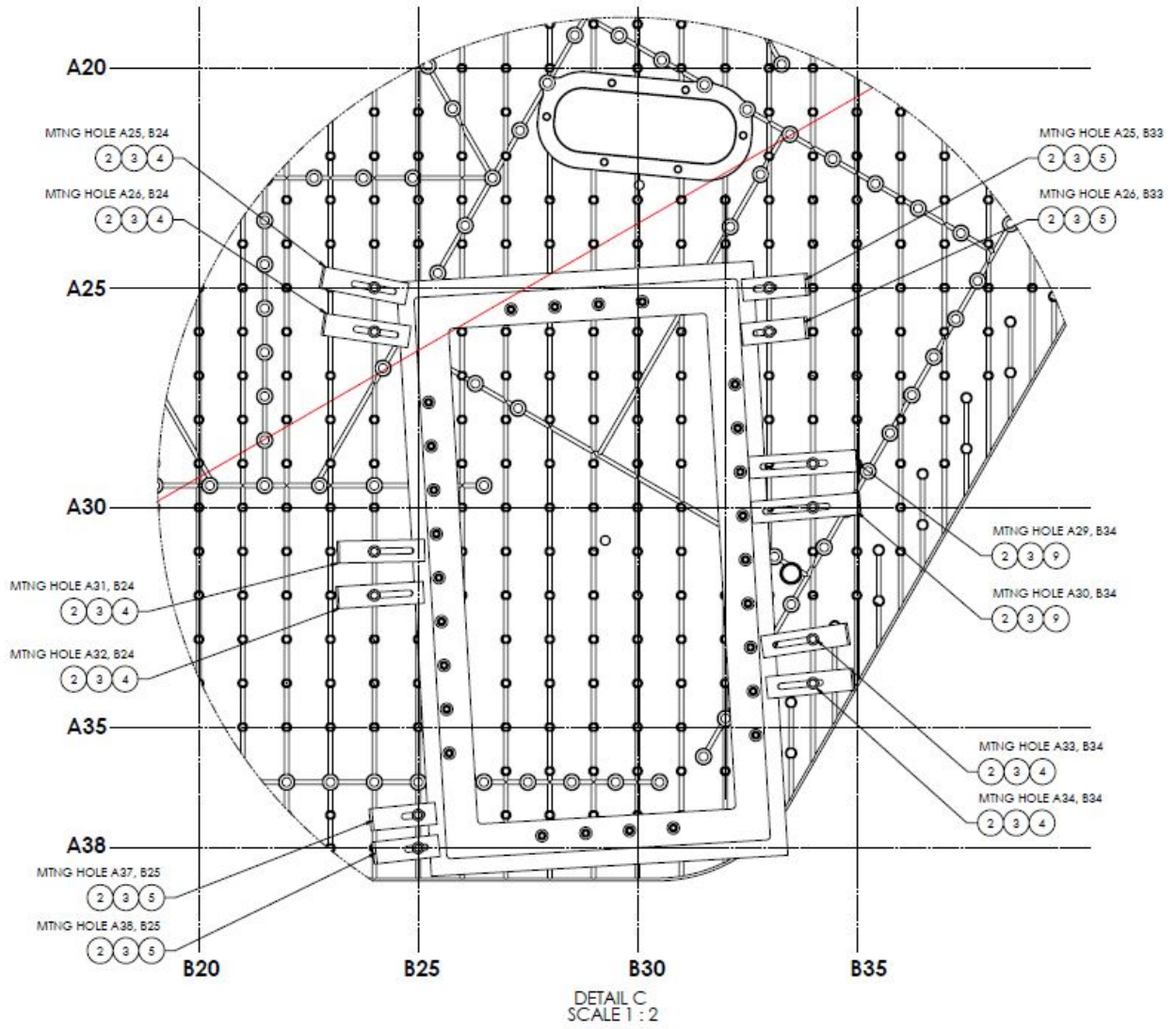

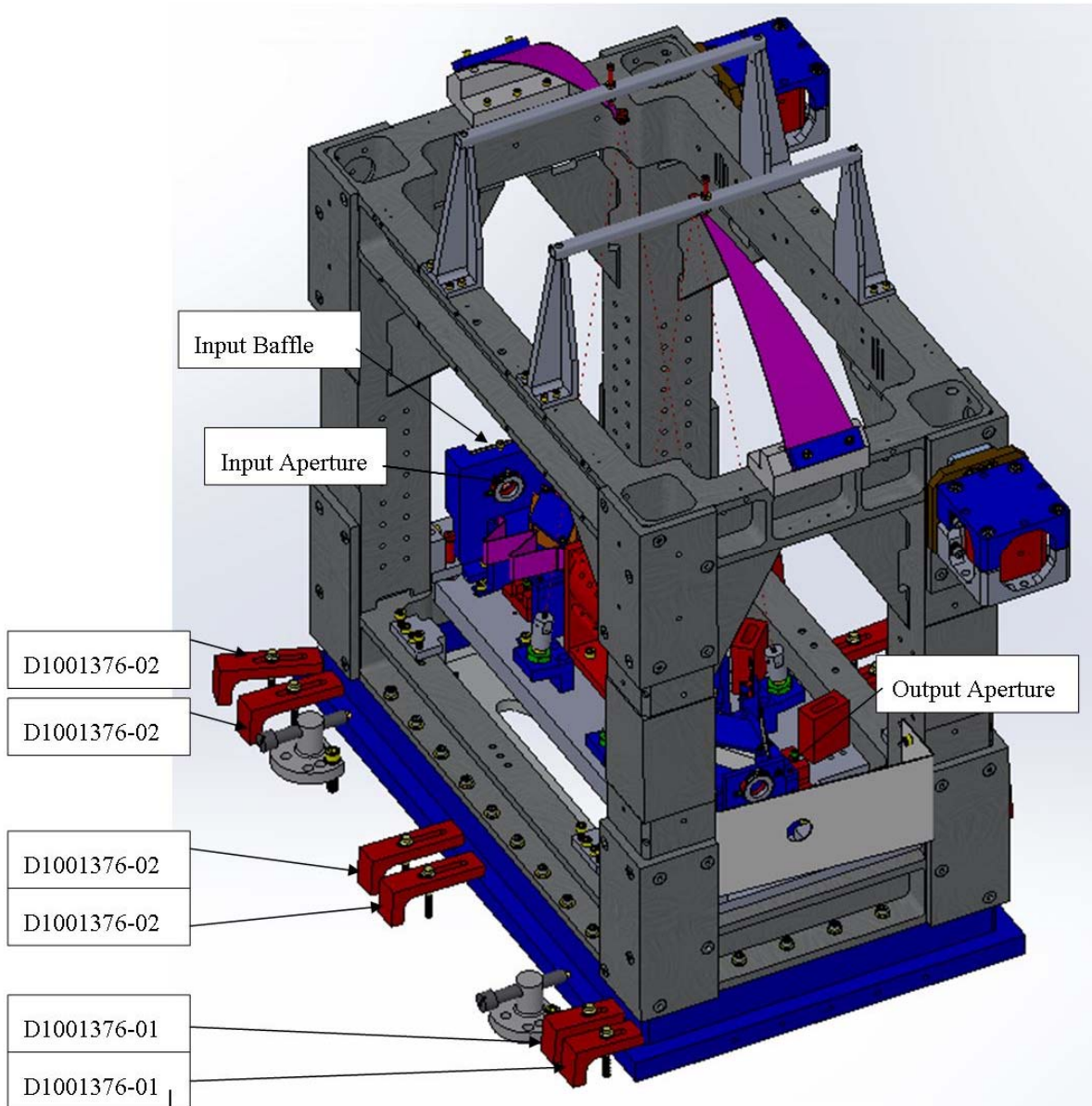

**Figure 9: OFI Assembly on HAM Table with Dog Clamps and BS Movers**

#### 4.2.2 Horizontal Alignment

- Place the IR fluorescent sensor card behind the SRM AR surface; flash the PSL laser, and view the beam spot on the card.



- Continue to flash the PSL laser and follow the beam through the SRM AR Baffle and to the OFI Beam Dump Wedge Window Input Baffle D1001920.
- Open the input aperture iris so that the beam passes through the iris and is seen on the IR card placed behind the iris.
- Translate the input side of the OFI Weldment by pushing with the BS Mover Assemblies so that the PSL beam is centered with the input iris in the transverse (horizontal) direction.
- Continue to flash the PSL laser and try to follow the beam along the OFI optical centerline through the Faraday Rotator, and out the open output iris.
- Translate the output side of the OFI Weldment (without laterally moving the input side) by pushing with the BS Mover Assemblies so that the PSL beam is centered with the output iris in the transverse (horizontal) direction. The input and output side alignment may need to be iterated.

If the beam is excessively misaligned vertically through the Input Aperture and vignettes along the OFI optical path, then proceed to the Vertical Alignment procedure.

### **4.2.3 Vertical Alignment**

- Adjust the height of the input side of the suspended OFI Table by turning the Wire Adjustable Adapters D0900586 to lengthen or shorten the input-side suspension wires until the PSL is centered on the input aperture.

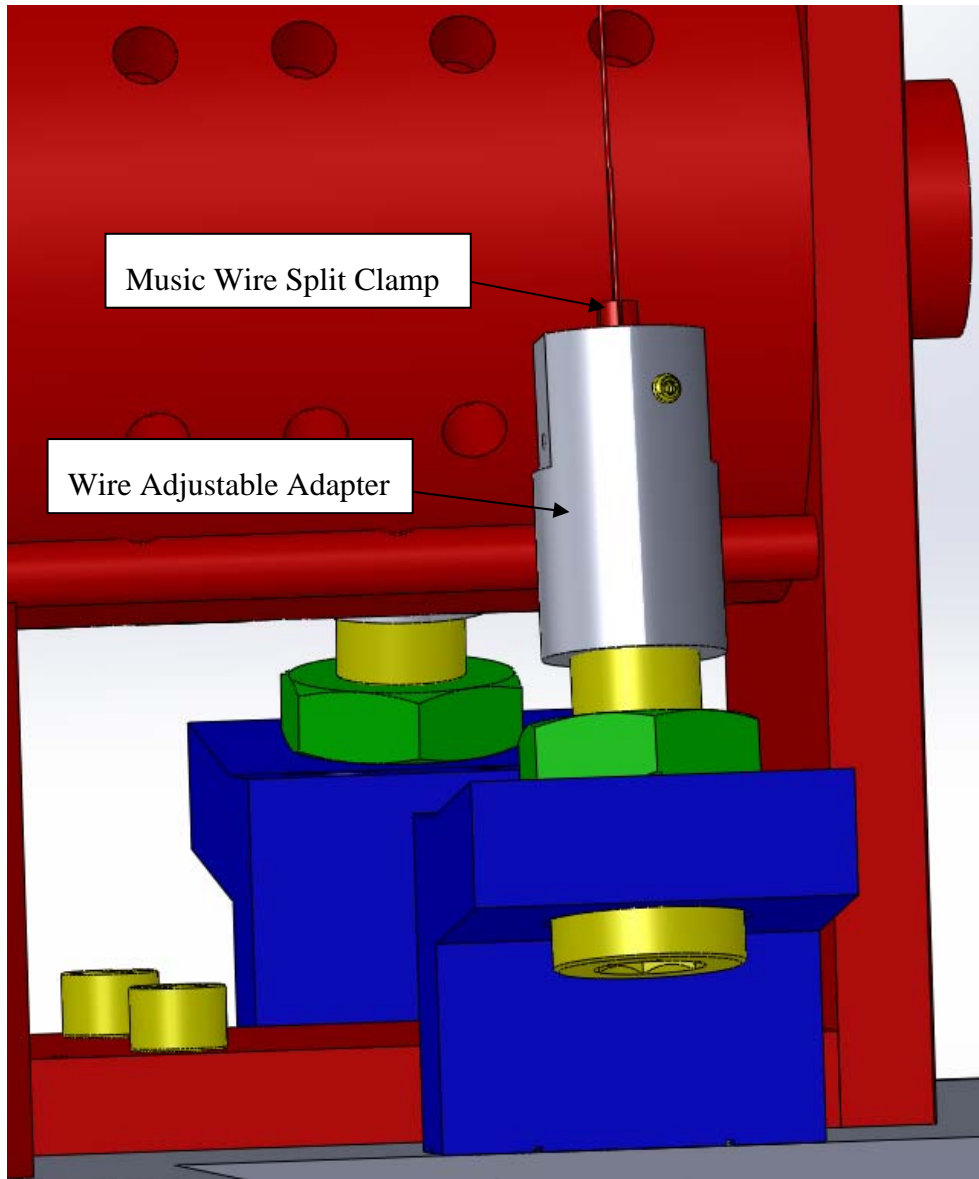

**Figure 10: Vertical Height Adjustment**

- The wire lengths of the input pair of wires must be matched so that the wires have approximately the same tension, as evidenced by the pitch they make when plucked. Place the guitar tuner against the base of the blade spring so that it will pick up the vibration of the wire when plucked. Pluck the wire as you would a guitar string and watch the frequency on the guitar tuner. Tension the wire by turning the Wire Adjustable Adapter while holding the Music Wire Split Clamp with a pair of pliers so that the Music Wire Split Clamp does not rotate within the Wire Adjustable Adapter, until the desired frequency is displayed on the guitar tuner. The objective is to match the frequencies of the two wires connected to the same blade spring. In general, the wire pairs from the front and back blade springs will have different frequencies because the blade springs may have different stiffness.

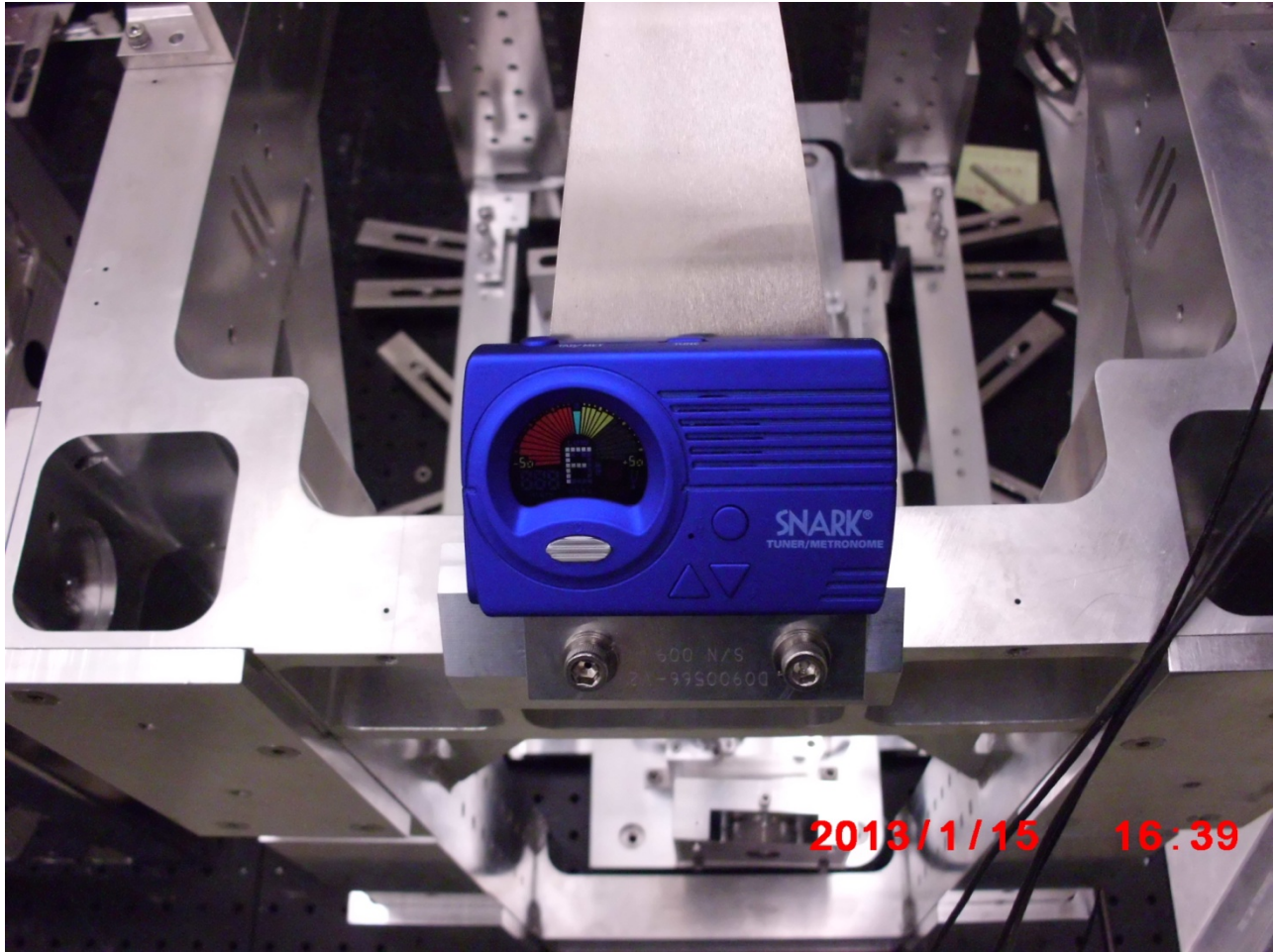
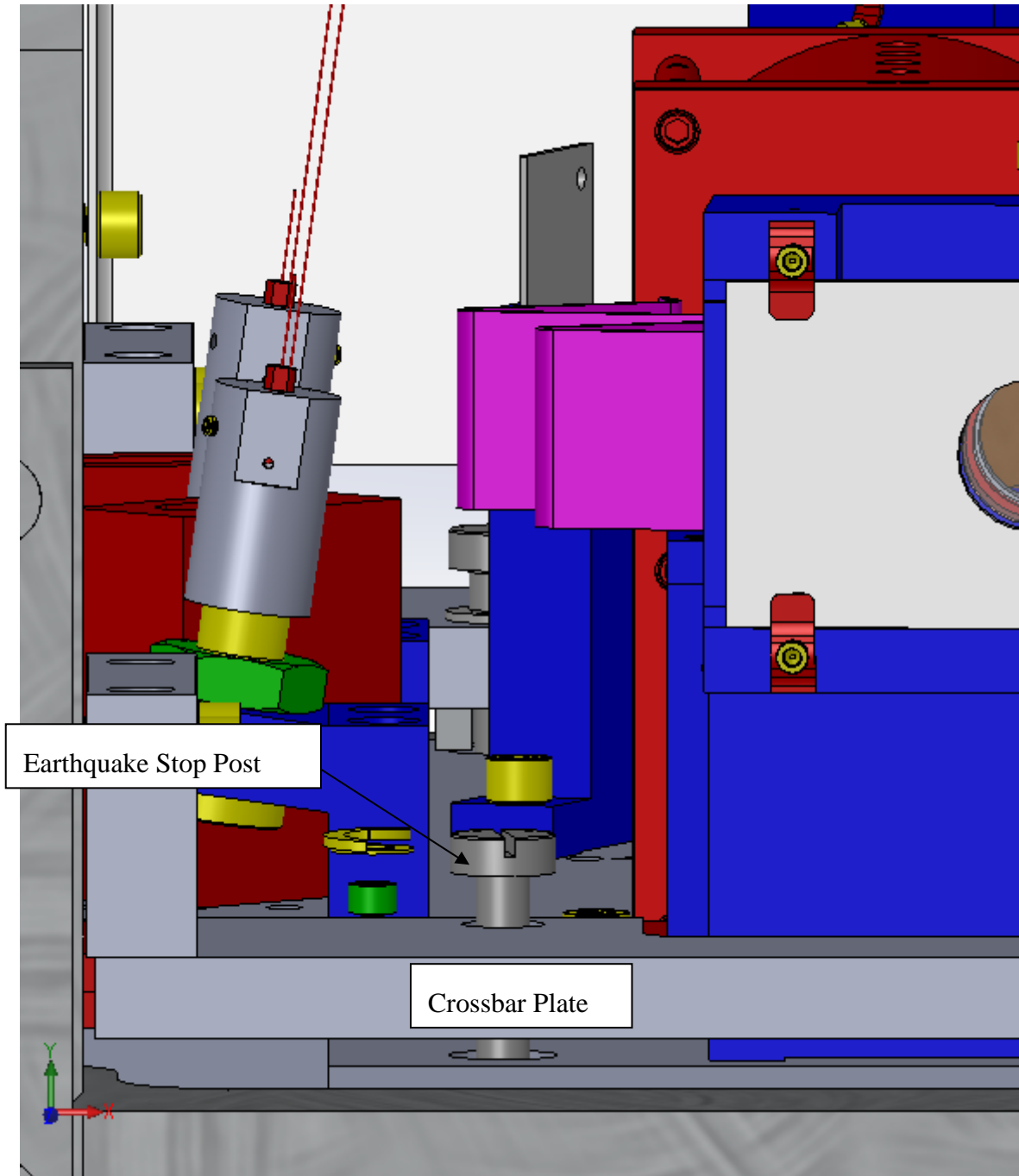

**Figure 11: Guitar Tuner to set Wire Tension**

- Adjust the height of the output side of the suspended OFI Table in the same manner until the PSL beam passes through the OFI and is centered vertically on the output alignment aperture.
- Iterate between the Horizontal and Vertical Alignment procedures until the beam is accurately centered on both the input and output alignment apertures.

- Verify that the earthquake stop posts are approximately centered within the Crossbar Plates. If they are not, then the suspension wire tensions may need to be re-adjusted to change the hanging orientation of the OFI Table.

□



□

**Figure 12: Earthquake Stop Posts Centered within Crossbar Plate**

#### 4.2.4 OFI Damper Holder Height Alignment

- Verify that the Damper Plate Mounting Bracket is 0.515 in above the Optics Table by placing the Damper Plate Height Gauge on each of the four Mounting Brackets and using the end of the height gauge with the 0.515 inch step.
- Raise or lower the Damper Holder Assembly at the four corners of the OFI structure by turning the 1/4-20 SHCS height adjustment screws to set it to the correct height, and then fasten the locking screws.

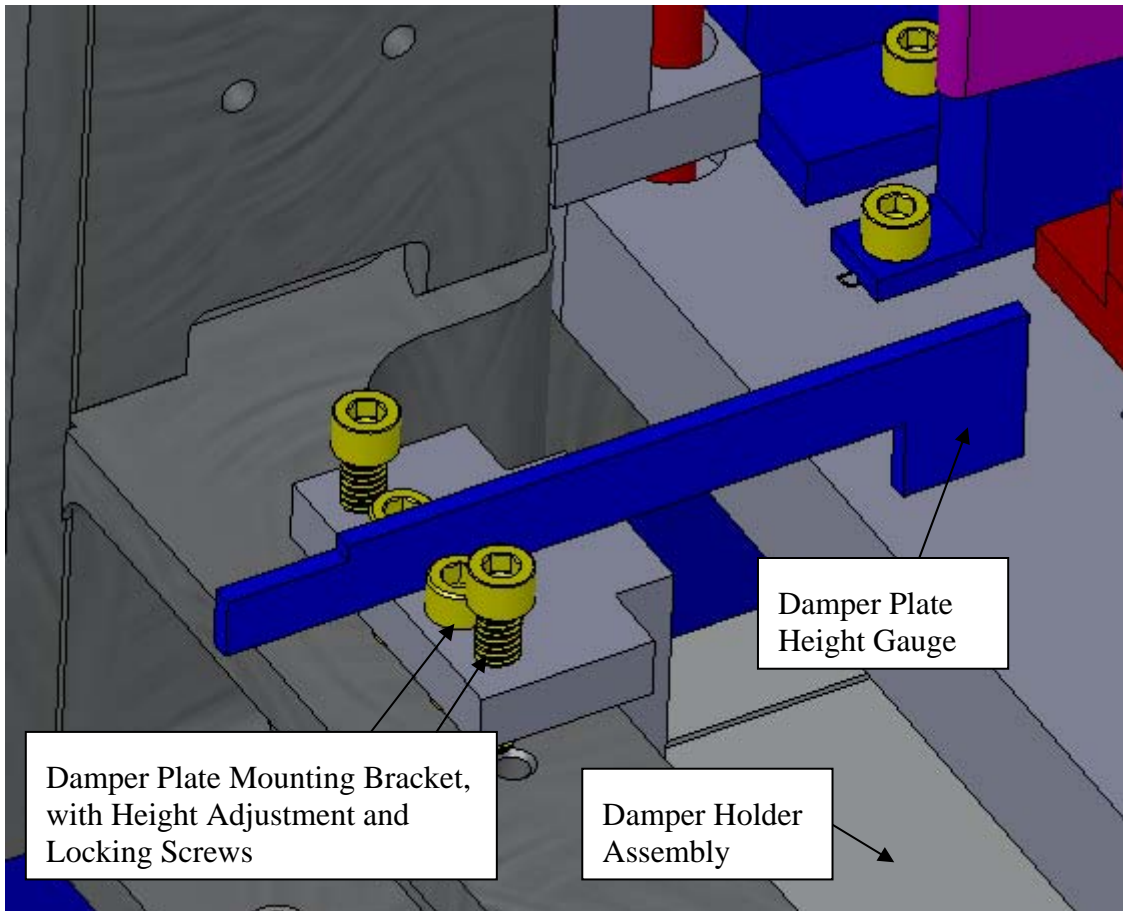

**Figure 13: Use the Damper Plate Height Gauge to verify that the Damper Holder Assy bracket is 0.515 in above the Optics Table**

- When the OFI alignment is complete, fasten the dog clamps securely to the OFI spacer, and remove all alignment tooling from the HAM chamber, including the input and output apertures, and BS Mover Assemblies.

#### 4.2.5 Nominal Height of OFI above HAM5 Table

The height of the IFO beam at the entrance aperture of the OFI is dependent upon the as-installed wedges of the ITMs. The following table provides nominal heights for a range of ITM wedges.

**Table 1: Nominal Height of IFO Beam at OFI**

IFO	ITMy Wedge Angle	height, mm	
		local	above HAM table
LLO	0.076	-98.8	226.2
LLO	0.072	-95.6	229.4
LLO	0.08	-102.12	222.9
max height difference		-6.563	
LHO	0.076	-117.19	207.8
LHO	0.072	-113.668	211.3
LHO	0.08	-120.706	204.3
max height difference		-7.038	