



LIGO Laboratory / LIGO Scientific Collaboration

LIGO-E1200839-v2

Advanced LIGO

12/12/12

Test Procedure for RF Preamplifier

Daniel Sigg, Maxim Factourovich

Distribution of this document:
LIGO Scientific Collaboration

This is an internal working note
of the LIGO Laboratory.

California Institute of Technology
LIGO Project – MS 18-34
1200 E. California Blvd.
Pasadena, CA 91125
Phone (626) 395-2129
Fax (626) 304-9834
E-mail: info@ligo.caltech.edu

Massachusetts Institute of Technology
LIGO Project – NW22-295
185 Albany St
Cambridge, MA 02139
Phone (617) 253-4824
Fax (617) 253-7014
E-mail: info@ligo.mit.edu

LIGO Hanford Observatory
P.O. Box 159
Richland WA 99352
Phone 509-372-8106
Fax 509-372-8137

LIGO Livingston Observatory
P.O. Box 940
Livingston, LA 70754
Phone 225-686-3100
Fax 225-686-7189

<http://www.ligo.caltech.edu/>

Serial number: S 1203934

1 Introduction

The following Test Procedure describes the test of proper operation of the RF Preamplifier. The unused outputs should always be properly terminated.

2 Test Equipment

- Voltmeter
- Tektronix TDS-30 series oscilloscope (or similar)
- Stanford Research SR785 analyzer (or similar)
- Wenzel 500-14928 33.289 MHz OCXO (or similar)
- Mini-Circuits ZSC-2-1 splitter & ZAD-3H mixer (or similar)
- Mini-Circuits CAT-6/HAT-6/HAT-3 attenuators (or similar)
- RF Power Meter HP E4418A
- DCC [D0900128](#) delay line (or similar)
- Board Schematics -- [D1201294](#)
- 50Ω terminators

3 Tests

The RF Preamplifier comes with the Low Noise Power Module ([D0901846](#)).

- 1) **Verify the proper current draw.** Using a bench DC supply apply ± 24 Volts to P7 and ± 17 Volts to P6 of the low noise power Module ([D0901846](#)). Measure the current draw of the board.

TEST POINT	Current, mA	
	Observed	Nominal
+24V	20	< 100
-24V	20	< 50
+17V	100	< 200
-17V	30	< 100

2) On the low noise power module check the voltage on TP 1-13.

TEST POINT	Voltage, V	
	Observed	Nominal
TP1	+17.2	+17.0
TP2	-17.1	-17.0
TP3, TP4	0.0	0.0
TP5	+5.0	+5.0
TP6	-15.0	-15.0
TP7	+24.0	+24.0
TP8	0.0	0.0
TP9	-24.1	-24.0
TP10	0.0	0.0
TP11	+15.0	+15.0
TP12	+10.0	+10.0 (+V _{REF})
TP13	-10.0	-10.0 (-V _{REF})

3) If TP 1 , 2, 7 , 9 and 8 are correct, then Pin 5 on U1 and U7, TP14 (OK) should be logic HIGH (~3Volts). The front panel LED should be on. Verify:

YES:

NO:

Value: +3.7V

4) The noise on TP 12, 13, 11 and 6 should be measured with a SR785 using an RMS power spectrum.

TEST POINT	Noise levels @ 144 Hz nV_{RMS} / \sqrt{Hz}	
	Observed	Nominal
TP6	20	< 1000
TP11	13	< 1000
TP12	9	< 200
TP13	14	< 900

5) Test the RF output powers by applying a 40 MHz/-13dBm RF signal to J1. With a RF power meter measure the power at the three outputs. Nominal output power is -14 dBm for the direct and 0 dBm for outputs 1 and 2.

OUTPUT	Power, dBm	
	Measured	Nominal
Direct	-13.7	-14
1	+1.7	0
2	+1.9	0

7) Measure the phase noise of the RF Oscillator Source driving the RF Preamplifier.

A suggested setup is depicted in the diagram below. A single RF source (e.g. Wenzel crystal oscillator) provides carrier signal for measuring the phase noise added by the Preamplifier. A variable delay unit is used to adjust the relative phase to 90°, as well as for calibration purposes. The available delay range must be sufficient for the frequency of the oscillator chosen. Usage of attenuators might be necessary to limit the input of the Preamplifier to -10dBm and to ensure that the reference input to the mixer exceeds the DUT output by about 6dB. A MHz-range low-pass filter is needed to reject the additive term of the mixer output that may affect the readings.

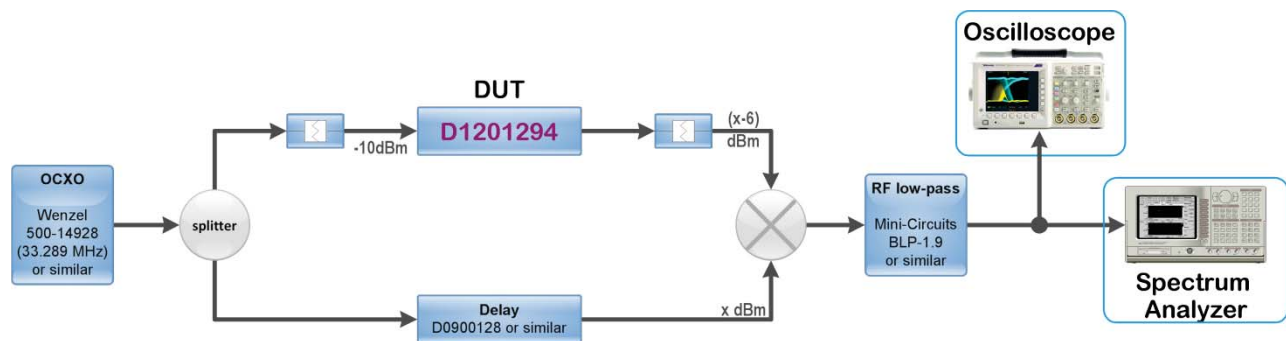

For initial testing, the following components were used:

- Wenzel 500-14928 crystal oscillator mounted on DCC [D0902708](#) board;
- Mini-Circuits ZSC-2-1 splitter/combiner;
- Mini-Circuits CAT-6, HAT-6 and HAT-3 attenuators;
- DCC D0900128 delay board;
- Mini-Circuits ZAD-3H multiplier/mixer;
- Mini-Circuits BLP-1.9 low-pass RF filter;
- Tektronix TDS3034 oscilloscope & Stanford Research SR785 spectrum analyzer

To calibrate the measurements, it is necessary to find the slope of the "beat-note". One of the ways of doing that is to have the two signals in-phase and measure the power output of the mixer. Monitor the output on the scope and use the delay unit to maximize the signal. Record the level (in Volts) and calculate the correction factor by taking the logarithm:

$$C = -20 \log V$$

For example, an observed [maximized] level of 260mV yields:

$$C = -20 \log(0.260) = 11.7$$

The calibrated phase noise value, in units of dBc/Hz , is simply

$$\Lambda = [PSD] - G + C$$

where $[PSD]$ is the level observed on the spectrum analyzer and G is the gain factor (in dB), if the signal is amplified.

Use the delay line to minimize the level of the mixer output, ideally – to zero. This is equivalent to setting the relative phase to 90° . **NOTE:** The phases of both, J3 and J4 outputs need to be adjusted individually. Then disconnect the scope in order to minimize unwanted noise. Set up the spectrum analyzer for a full-span FFT measurement in units of $\text{dBV}_{\text{RMS}}/\sqrt{\text{Hz}}$, and to the highest possible sensitivity. Averaging can also be used to smoothen out the noise curve.

Terminate the input of the spectrum analyzer with a 50Ω resistor and measure the device' noise floor. Then connect the Preamplifier and record the levels for both outputs at 1, 3, 10, 30 and 100 kHz. Make sure they are considerably above the noise floor. Otherwise use a low-noise amplifier and adjust the values for the gain factor. Then terminate the RF Preamplifier input with a 50Ω resistor and measure the noise levels for the same frequencies again. Fill in the table below. All the levels should stay below the reference, while the levels with the driven input should be about 3dB lower than those with the terminated one.

Offset frequency, kHz	J3		J4		Reference level, dBc/Hz
	OCXO	50 Ω	OCXO	50 Ω	
1	-142	-139	-142	-141	-130
3	-144	-141	-144	-140	-130
10	-143	-141	-144	-140	-130
30	-143	-141	-144	-141	-130
100	-144	-142	-144	-142	-130

[THE END]