



LIGO Laboratory / LIGO Scientific Collaboration

LIGO-E1200660-v3

LIGO

7/30/12

AOS SLC BS Elliptical Baffle Installation Procedure

Michael Smith, Lisa C. Austin, Kurt Buckland

Distribution of this document:
LIGO Scientific Collaboration

This is an internal working note
of the LIGO Laboratory.

California Institute of Technology
LIGO Project

Massachusetts Institute of Technology
LIGO Project

LIGO Hanford Observatory

LIGO Livingston Observatory

<http://www.ligo.caltech.edu/>

CHANGE LOG

Date, version	Summary of Changes
7-30-12	<ul style="list-style-type: none">• Added reference to M1200268, RODA
	<ul style="list-style-type: none">•

Table of Contents

1	<i>Scope</i>	5
1.1	Related Documents	5
1.2	BS Elliptical Baffle Installation Summary	5
2	<i>Assembly Procedure</i>	6
3	<i>Installation Preparation</i>	7
3.1	Requirements for Installation	7
3.2	Items required for installation	7
3.3	Tools required for Installation	7
4	<i>Installation Procedure</i>	7
4.1	Installation Set-up	7
4.2	Baffle Installation	7
5	<i>Alignment Procedure</i>	9
5.1	Elliptical baffle alignment tool installation	9
5.2	Baffle Alignment	10
5.3	Baffle removal	10
7	<i>Removal of Fixtures and Tooling</i>	12

Table of Figures

<i>Figure 1:</i>	<i>Model of BS Elliptical Baffles Installed on the BS SUS</i>	<i>5</i>
<i>Figure 2:</i>	<i>Exploded View of BS Elliptical Baffle Installation</i>	<i>6</i>
<i>Figure 3:</i>	<i>Installed View of BS Elliptical Baffles</i>	<i>8</i>
<i>Figure 4:</i>	<i>Installed View of BS Elliptical Baffles, Showing Upper Fasteners</i>	<i>9</i>
<i>Figure 5:</i>	<i>Alignment Tooling</i>	<i>10</i>
<i>Figure 6:</i>	<i>BS Elliptical Baffle Removal</i>	<i>11</i>

1 Scope

This document describes the installation and alignment procedures for the BS Elliptical Baffle.

1.1 Related Documents

T1200376 aLIGO Beam Splitter Elliptical Baffle Installation Instructions

D1200750-v1 BS ELLIPTICAL BAFFLE ASSEMBLY

D1200901-v1 BS ELLIPTICAL BAFFLE ALIGNMENT TOOL

D0900431 AdvLIGO SUS BSC2-L1, XYZ Local CS for BS HR

D0900484 AdvLIGO SUS BSC4-H2, XYZ Local CS for BS HR

D0901445 AdvLIGO SUS BSC2-H1, XYZ Local CS for BS HR

E1200392-v5 Initial Alignment Procedure LBSC2

1.2 BS Elliptical Baffle Installation Summary

A model of the Installed BS Elliptical Baffle is shown in Figure 1.

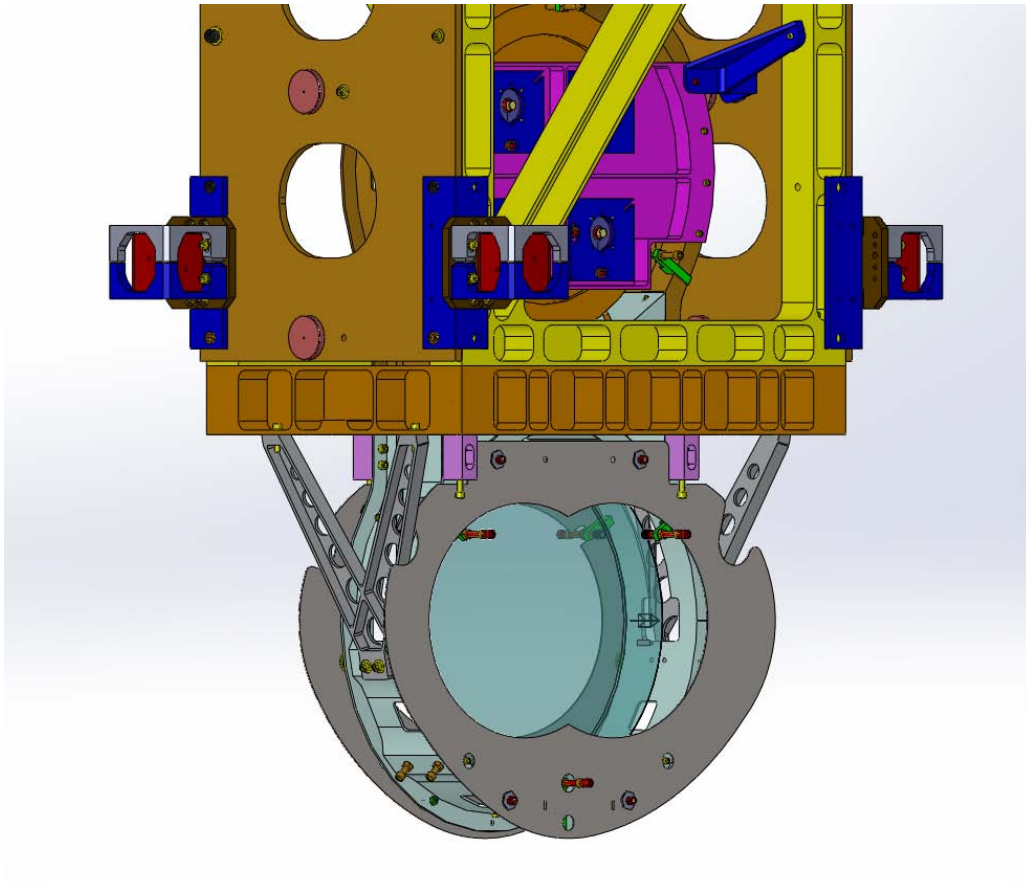

Figure 1: Model of BS Elliptical Baffles Installed on the BS SUS

The 5 lb BS Elliptical Baffle (both baffles plus hardware) is attached to the BS SUS lower frame, as shown in Figure 1. Installation and alignment will occur on the Cartridge assembly.

The Baffles will be attached, using special mounting hardware, after the BS mirror and suspension structure have been installed and aligned on the BSC ISI optical platform.

The IAS theodolite, aligned perpendicular and centered on the BS mirror, will sight on the crosshairs of the alignment target mounted at the center of the BS Elliptical Baffle elliptical hole; the Baffle will be translated within the oversize mounting holes until the mounted target is aligned with the Theodolite.

2 Assembly Procedure

Pre-assemble BS X ELLIPTICAL BAFFLE (D1200703) and BS Y ELLIPTICAL BAFFLE (D1200704), with the following mounting hardware loosely attached—BS ELLIPTICAL BAFFLE SPACER (D1200748); HEX NUT #3/8-16 X .257 SILVER PLATED, UC CO. (N-3816-A); FLAT WASHER, 3/8, MS15795-814, MC#98019A399 (98019A399). See the exploded view below.

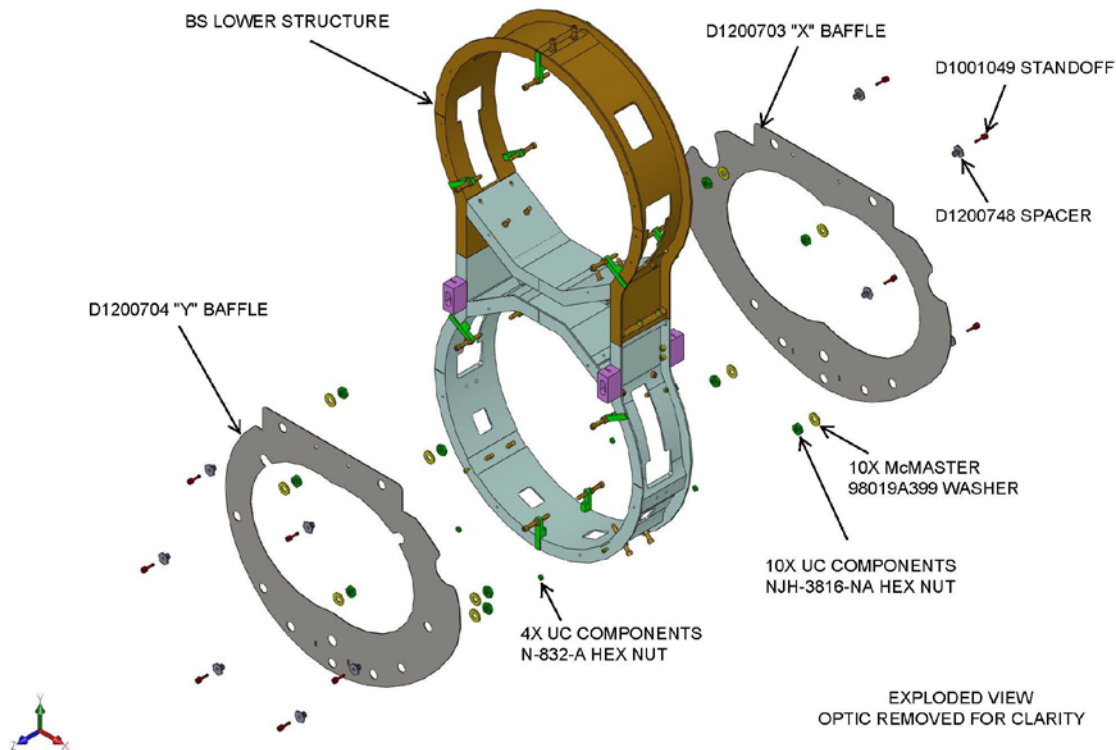

Figure 2: Exploded View of BS Elliptical Baffle Installation

3 Installation Preparation

3.1 Requirements for Installation

BS mirror must be aligned on the Cartridge assembly.

BS SUS and BS mirror must be secured and protected (ask SUS) – at least the penultimate and final masses should be on their stops.

Place a protective barrier between the BS surface and the BS Elliptical Baffle.

3.2 Items required for installation

2, Pre-assembled BS X ELLIPTICAL BAFFLE (D1200703) and BS Y ELLIPTICAL BAFFLE (D1200704), with the following mounting hardware loosely attached—BS ELLIPTICAL BAFFLE SPACER (D1200748); HEX NUT #3/8-16 X .257 SIVER PLATED, UC CO. (N-3816-A); FLAT WASHER, 3/8, MS15795-814, MC#98019A399 (98019A399)

SLC FM ELLIPTICAL BAFFLE STANDOFF ADAPTER #8-32 (D1001049) with HELI-COIL INSERT #8-32 X 1 DIA (1185-2EN 164), NITRONIC 60

4, HEX NUT #8-32 SIVER PLATED; UC CO. (N-832-A), Ag Plated 18-8 SSTL

BS Elliptical Baffle Alignment Tool Assy (D1200901)

3.3 Tools required for Installation

1 – 7/64 Hex L-Key tool for 6-32 SHCS

1 – 9/64 Hex L-Key tool for 8-32 SHCS

1 – 11/32 Wrench for 8-32 Hex Nut

1 – 11/16 Wrench for 3/8-16 Hex Nut

1 – Emhart # 7551-2 Helicoil Insertion Tool for 8-32 Helicoil

4 Installation Procedure

4.1 Installation Set-up

Pre-assemble the items in Section 2.2 per [D1200750](#), [D1200901](#), [T1200376-v1](#).

Verify that IAS has completed the BS mirror alignment and has removed the alignment corner cube and any attachment hardware that uses the shared holes in the BS SUS to which the BS Elliptical baffle will be attached.

4.2 Baffle Installation

Place each pre-assembled Baffle against the BS SUS and insert the SLC FM ELLIPTICAL BAFFLE STANDOFF ADAPTER #8-32 (D1001049) with HELI-COIL INSERT #8-32 X 1 DIA (1185-2EN 164), NITRONIC 60 into the tapped hole or through the clearance hole in the BS SUS. Fasten the standoff adapter into the tapped hole with the prescribed torque value; fasten the HEX NUT #8-32 SIVER PLATED; UC CO. (N-832-A), Ag Plated 18-8 SST to the standoff adapters that pass through the clearance holes in the BS SUS with the prescribed torque value.

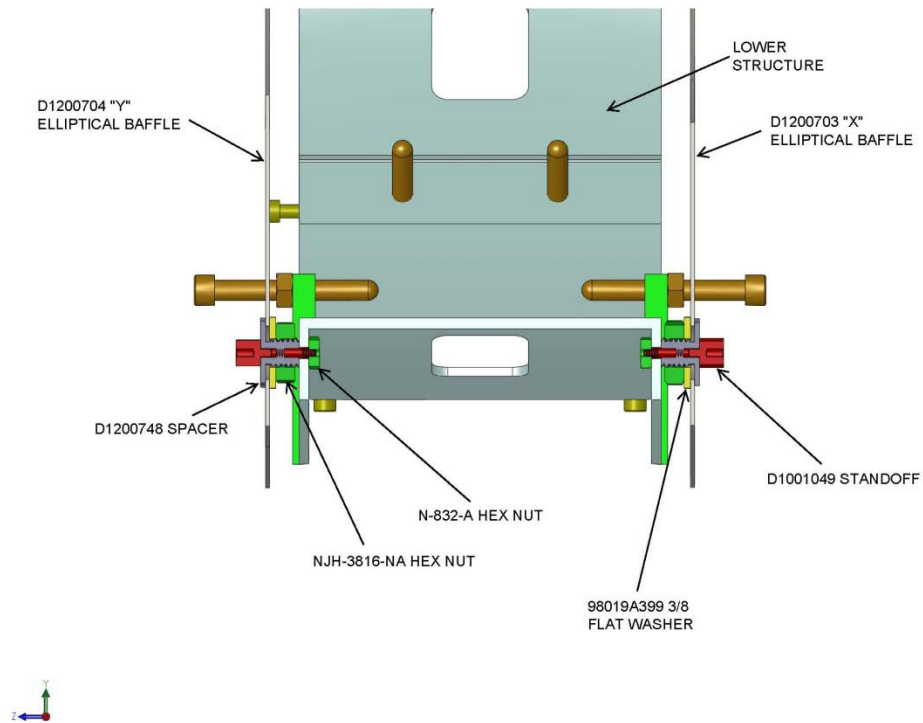
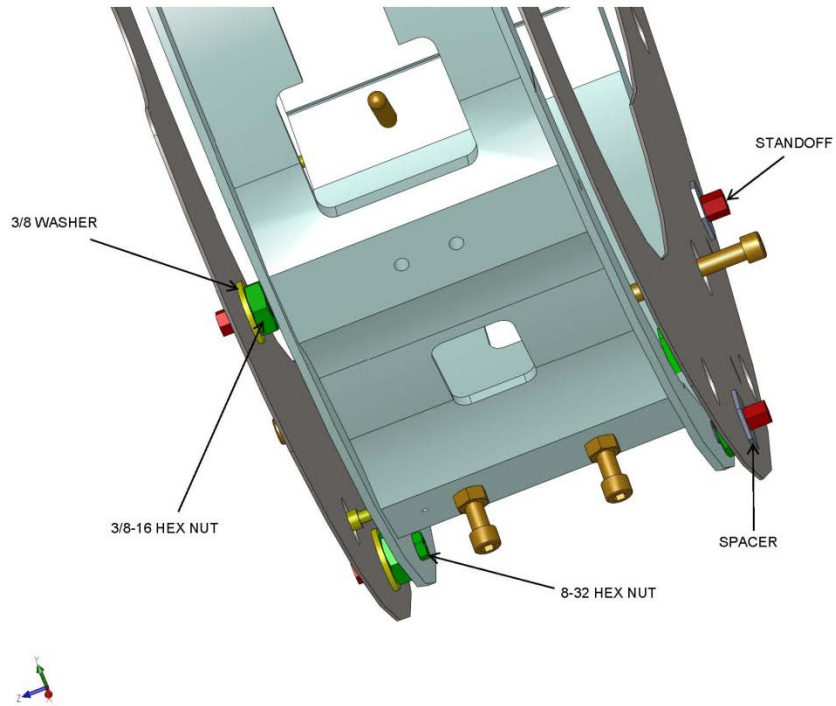

Figure 3: Installed View of BS Elliptical Baffles

The 3/8-16 nuts should be loose at this stage so that the baffle can be moved freely within the mounting clearance holes. Leave all but the upper 2 positions loose to allow for alignment. Snug the upper 2 positions to keep the elliptical baffles in place.

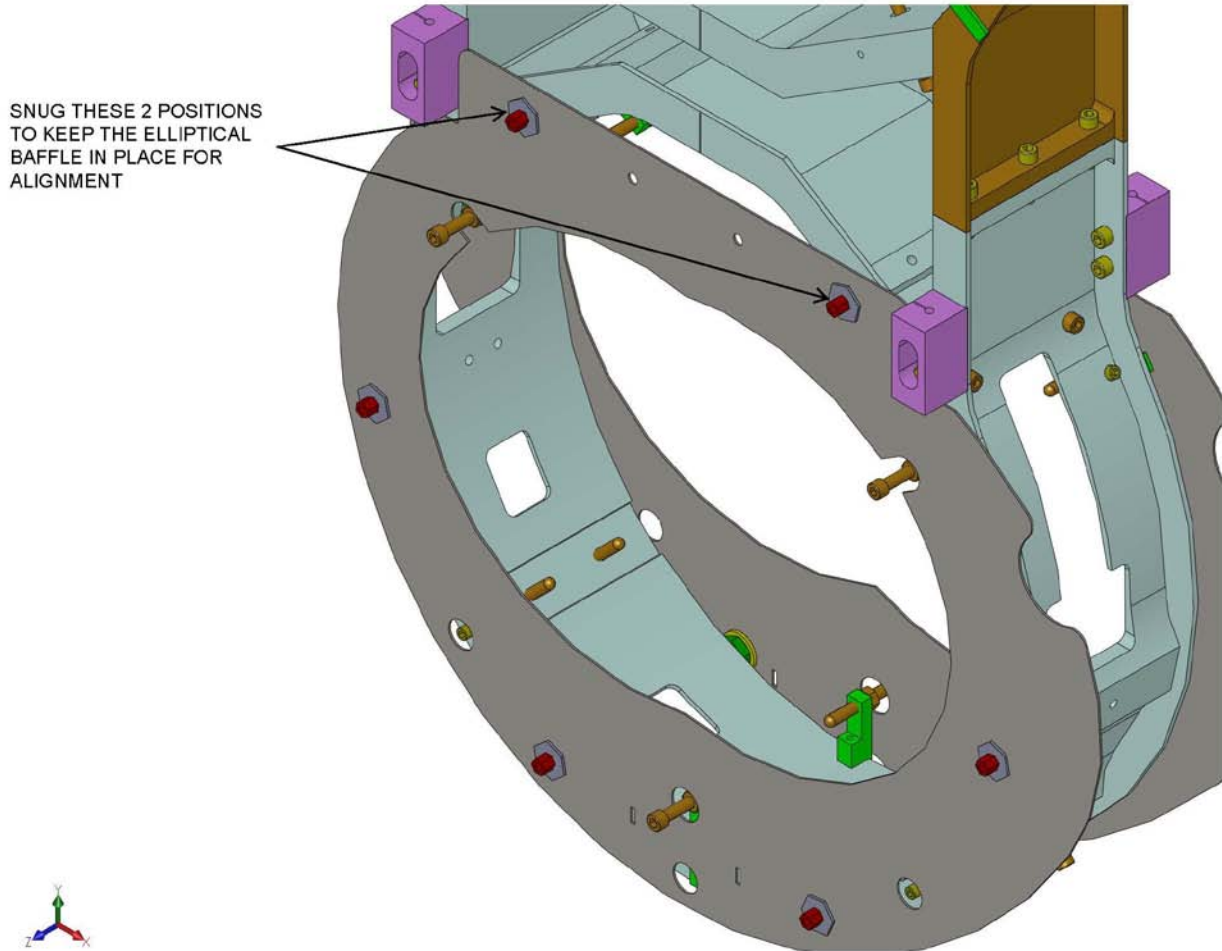

Figure 4: Installed View of BS Elliptical Baffles, Showing Upper Fasteners

Notes:

- 1) The super 8 polished sides of the x and Y Baffles must face away from the BS lower structure.
- 2) The 4 N-632-A hex nuts are only used on the bottom 2 holes of each elliptical baffle. The remaining D1001049 standoffs screw directly into the BS lower structure.

5 Alignment Procedure

5.1 Elliptical baffle alignment tool installation

Attach the D1200901 alignment tool to each baffle plate as shown. Adjust the position of the elliptical baffle by carefully moving the elliptical baffle plate until the alignment theodolite cross

hairs are centered on the scribed cross on the alignment tool. Once alignment is complete, tighten all the NJH-3816-NA hex nuts to lock the elliptical baffles in place.

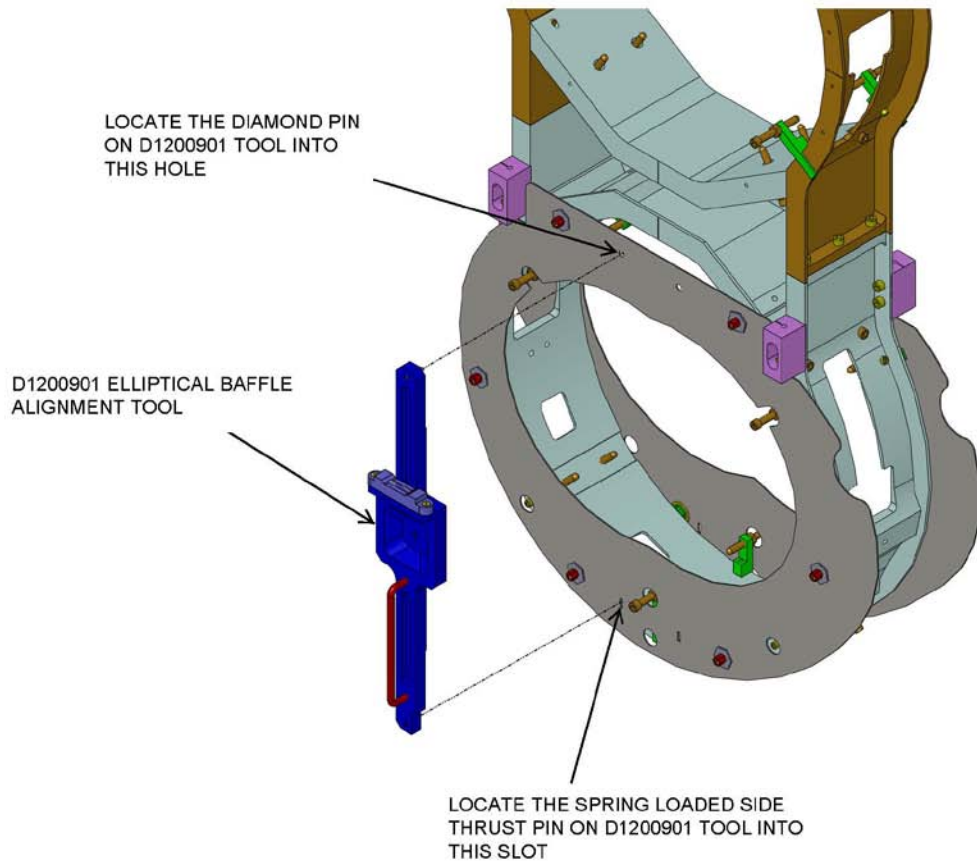

Figure 5: Alignment Tooling

5.2 Baffle Alignment

- 1 Move the Baffle horizontally and vertically within the mounting clearance holes until the alignment target is centered on the alignment theodolite ± 0.5 mm horizontally, and ± 1 mm vertically, per [M1200268](#), RODA.
- 2 After alignment, secure the Baffle to the BS SUS frame by firmly tightening the 3/8-16 nuts with the prescribed torque value.
- 3 Remove the alignment target.

5.3 Baffle removal

In the event that access is needed for maintenance of the BS mirror (to add or remove first contact, etc), the Baffles will be removed together with the STANDOFF ADAPTERs and mounting HEX NUT #8-32.

Remove the D1001049 standoffs – **do not loosen or remove the NJH-3816-NA hex nuts**; remove the elliptical baffle with the spacer, washer and hex nut firmly attached. This will allow the re-installation of the elliptical baffle without needing to re-align its position.

Removed Baffle with hardware.

Use extreme care when handling the elliptical baffle with attached hardware to prevent loosening of the spacer and locking nut.

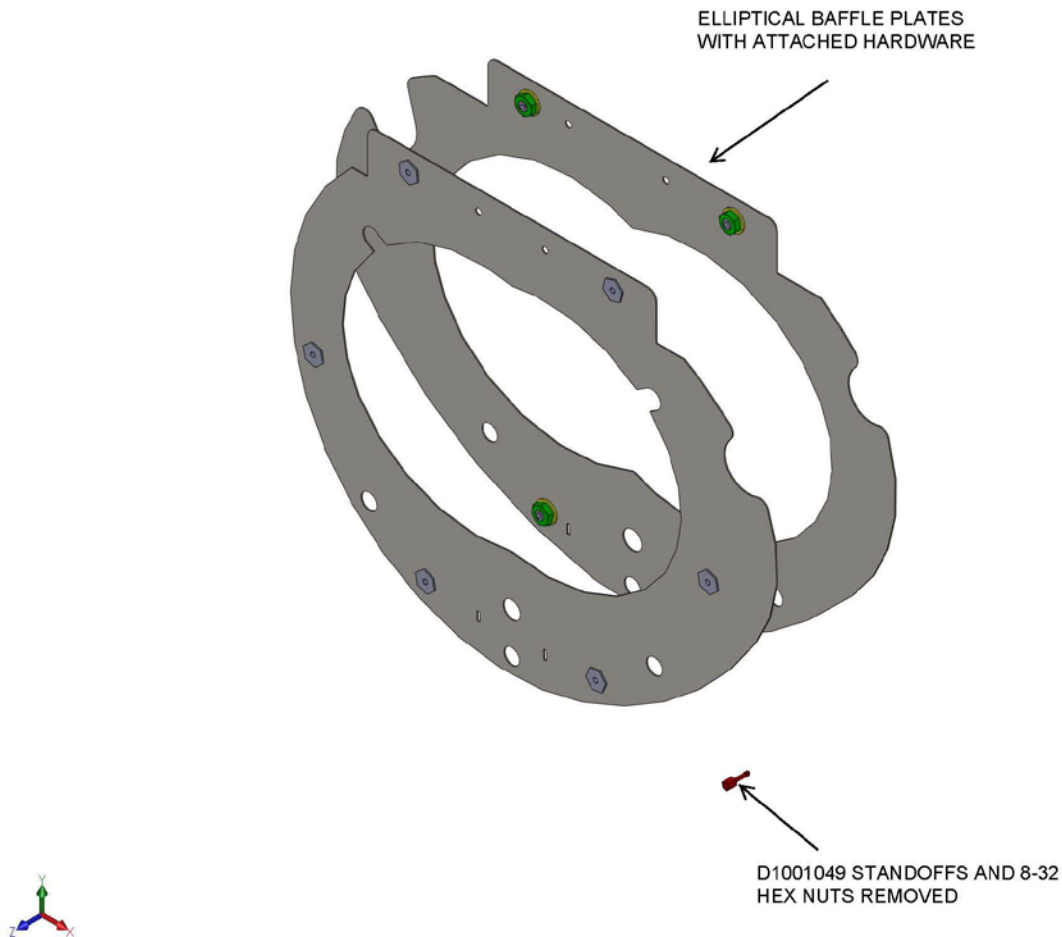

Figure 6: BS Elliptical Baffle Removal

After repair of the BS mirror, the Baffle will be re-installed without the need for subsequent alignment by re-fastening the FM ELLIPTICAL BAFFLE STANDOFF ADAPTERs to the BS SUS.

7 Removal of Fixtures and Tooling

Check that all fixtures and tools are removed from the Cartridge after installation and alignment of the BS Elliptical Baffle.