

opto-mechanical filtering

Robert L. Ward
Australian National University

Gravitational Wave Advanced Detector Workshop
Waikoloa, HI, 2012

squeezing accomplished

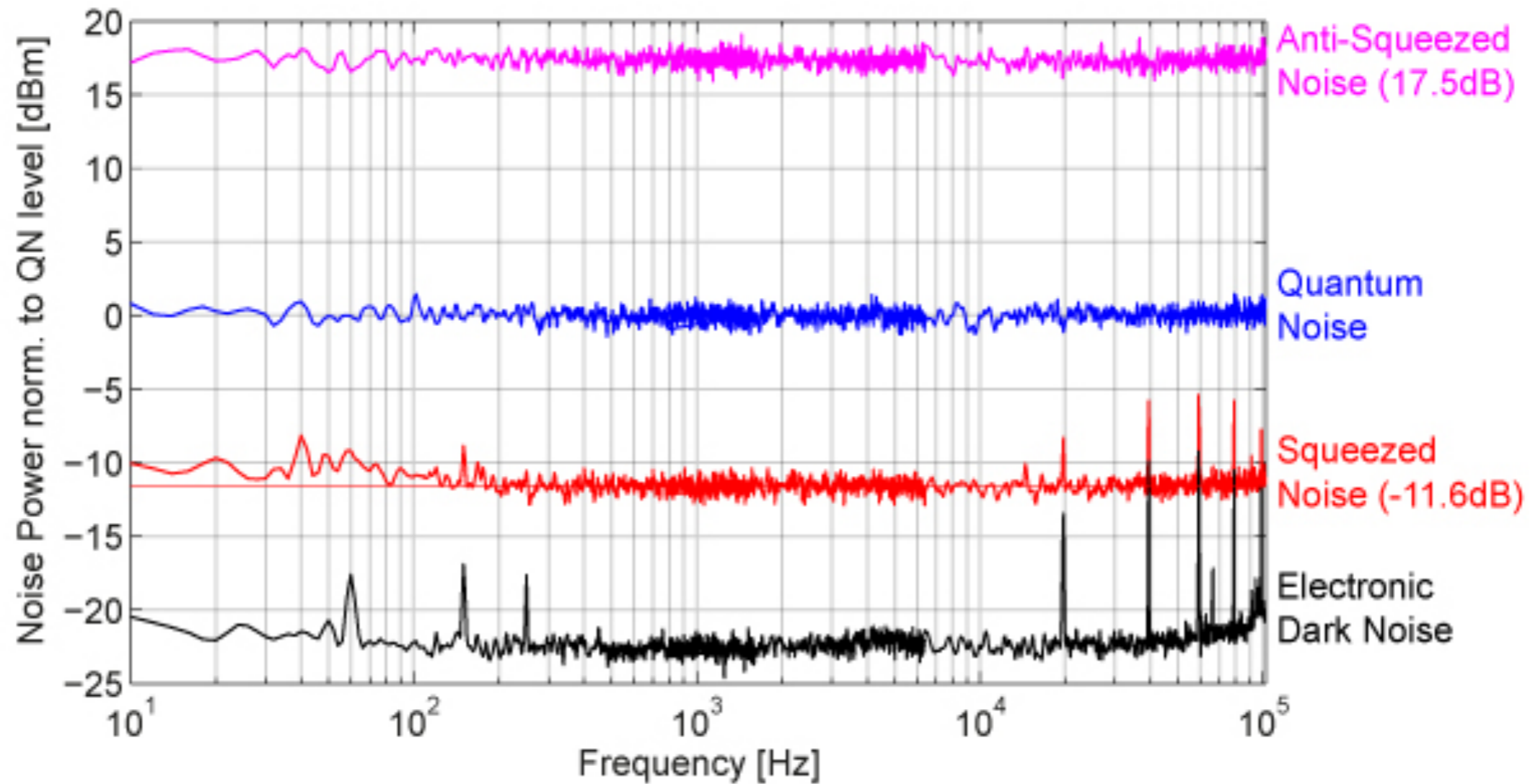

now that we've got the ellipse we need, let's rotate it

workshop

- This is a “workshop” presentation.
- I’m hoping you will understand what I’m trying to say, so you can explain it to me later today by the pool.

ponderomotive--optical rigidity

- the radiation pressure on a moveable mirror converts amplitude modulation into phase modulation.
- this coupling of the quadratures can be used to generate squeezing.
- the dispersion resulting from the optical rigidity can also be used to filter an already-squeezed input field.

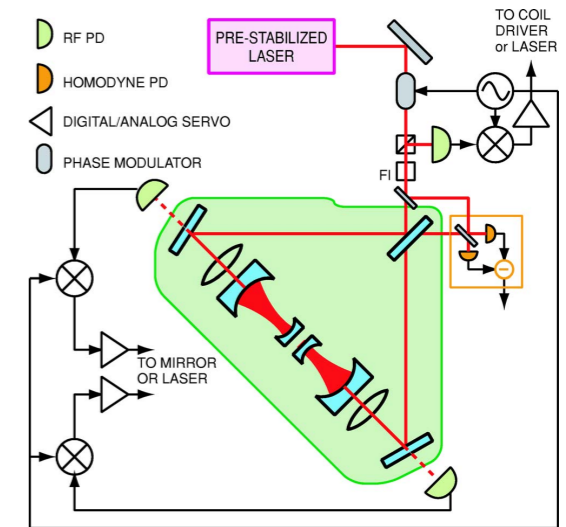

Thomas Corbitt, Yanbei Chen, Farid Khalili, David Ottaway, Sergey Vyatchanin, Stan Whitcomb, and Nergis Mavalvala. Squeezed-state source using radiation-pressure-induced rigidity.

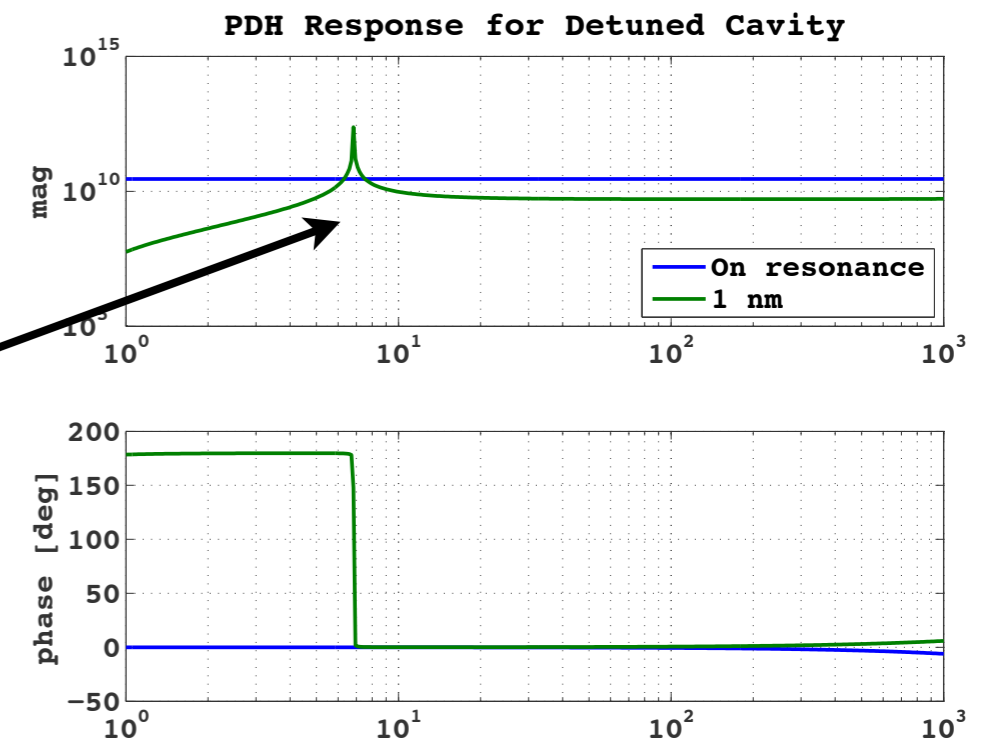

ponderomotive squeezing recently reported

D. W. C. Brooks, T. Botter, N. Brahms, T. P. Purdy, S. Schreppler, and D. M. Stamper-Kurn. Ponderomotive light squeezing with atomic cavity optomechanics. *ArXiv e-prints*, July 2011.

opto-mechanically induced transparency

- using the ponderomotive effect, OMIT is an optomechanical analogue of electromagnetically induced transparency

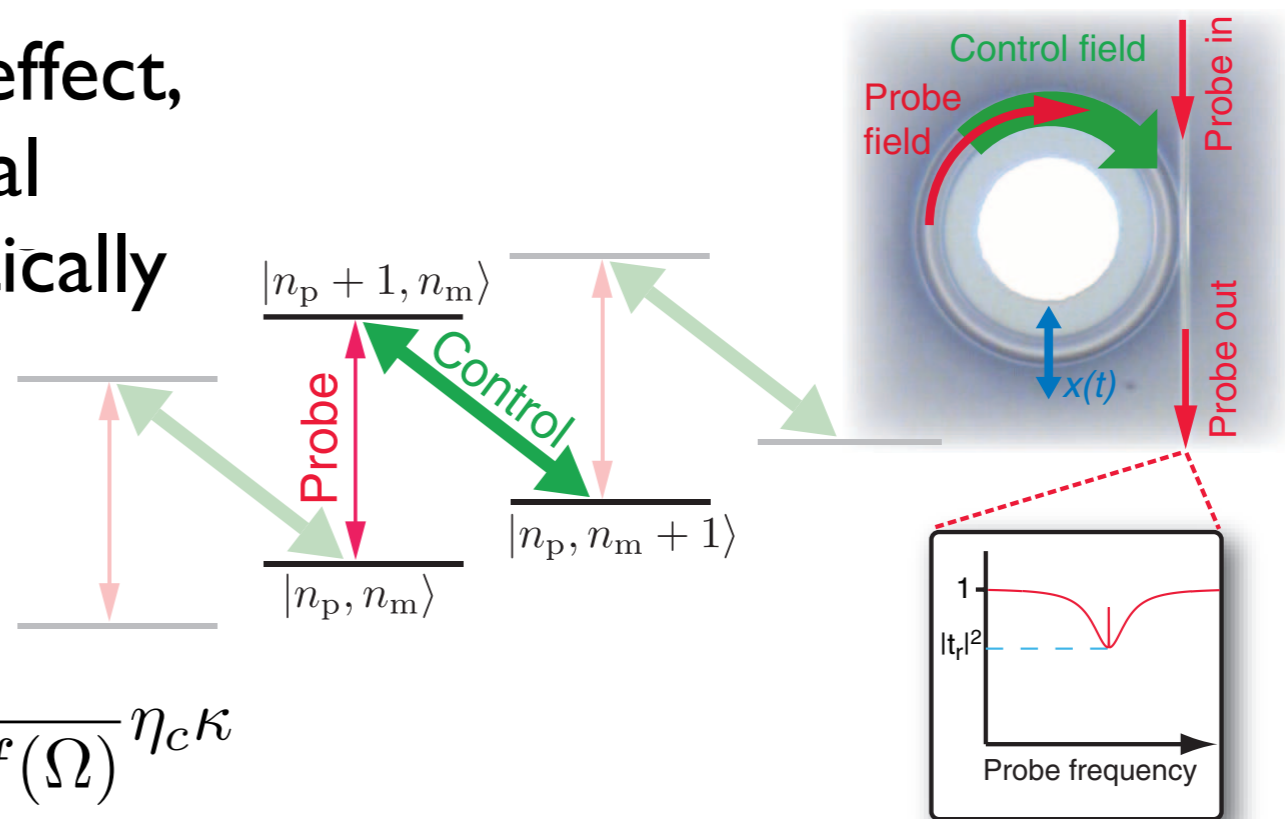

$$r_{probe} = 1 - \frac{1 + if(\Omega)}{-i(\Delta + \Omega) + \kappa/2 + 2\Delta f(\Omega)} \eta_c \kappa$$

$$f(\Omega) = \hbar G^2 \bar{a}^2 \frac{\chi(\Omega)}{i(\Delta - \Omega) + \kappa/2}$$

$$\chi(\Omega) = \frac{1}{m_{eff}} \frac{1}{\Omega_m^2 - \Omega^2 - i\Omega\Gamma_m}$$

Stefan Weis, Rémi Rivière, Samuel Deléglise, Emanuel Gavartin, Olivier Arcizet, Albert Schliesser, and Tobias J. Kippenberg. Optomechanically induced transparency. *Science*, 330(6010): 1520–1523, 2010.

OMIT and ponderomotive squeezing are kind of the same thing

Thierry Botter, Daniel W. C. Brooks, Nathan Brahms, Sydney Schreppler, and Dan M. Stamper-Kurn. Linear amplifier model for optomechanical systems. *Phys. Rev. A*, 85:013812, Jan 2012.

cavity reflection

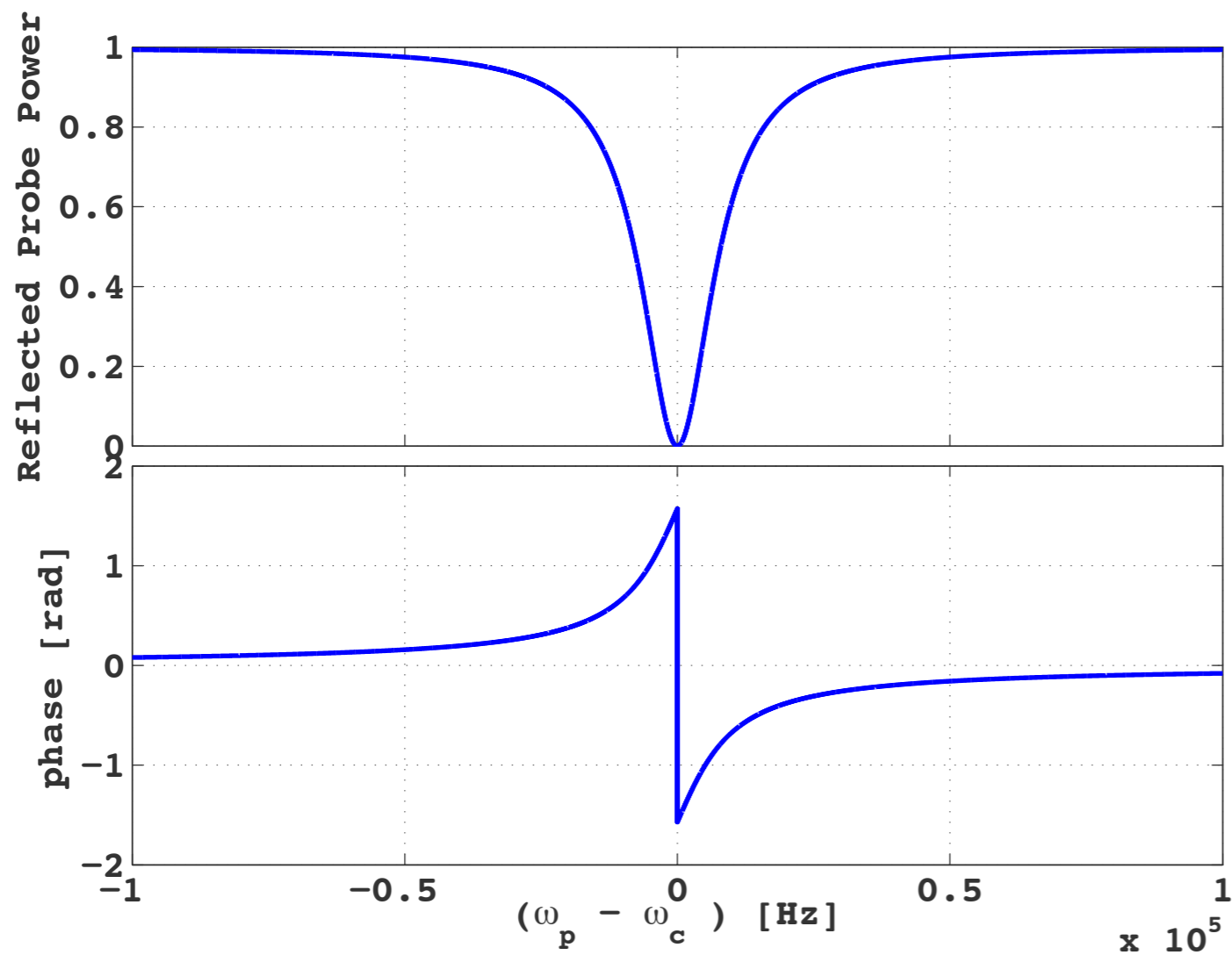

cavity linewidth $\kappa = 100 \text{ kHz}$

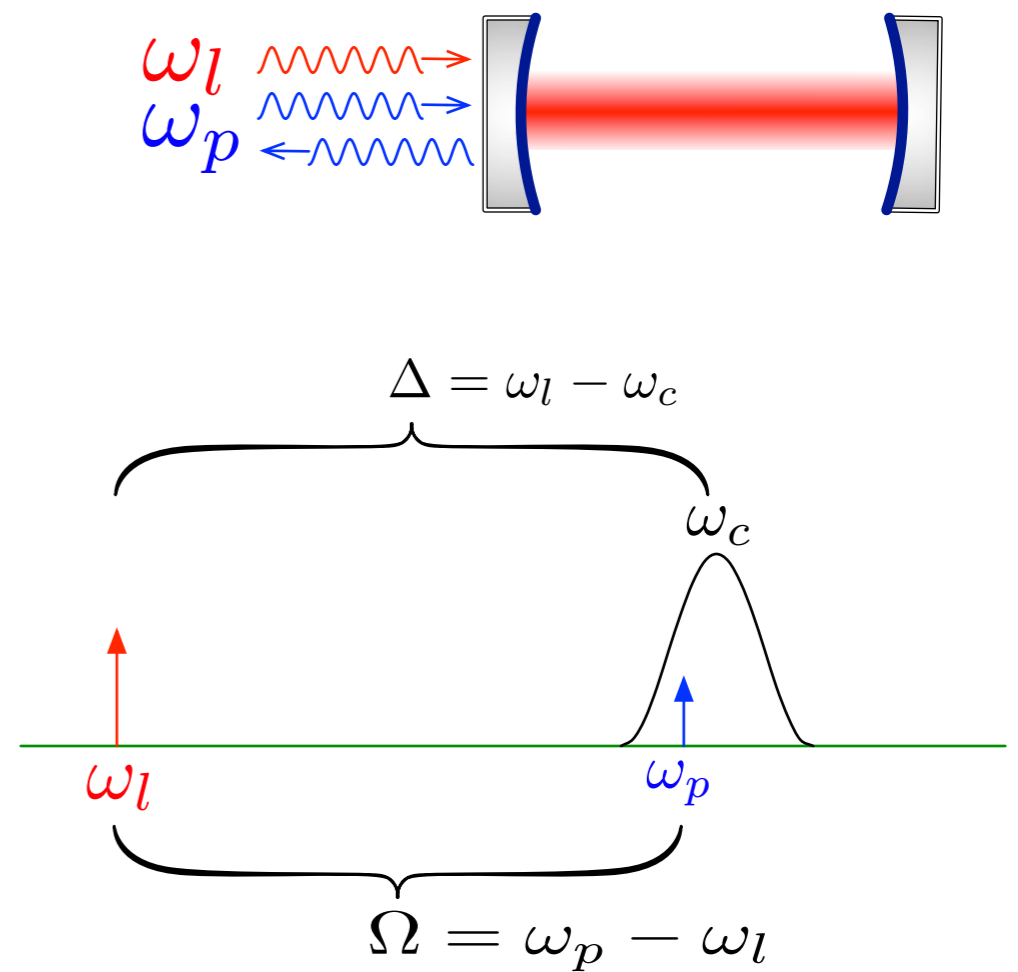

make the back mirror moveable

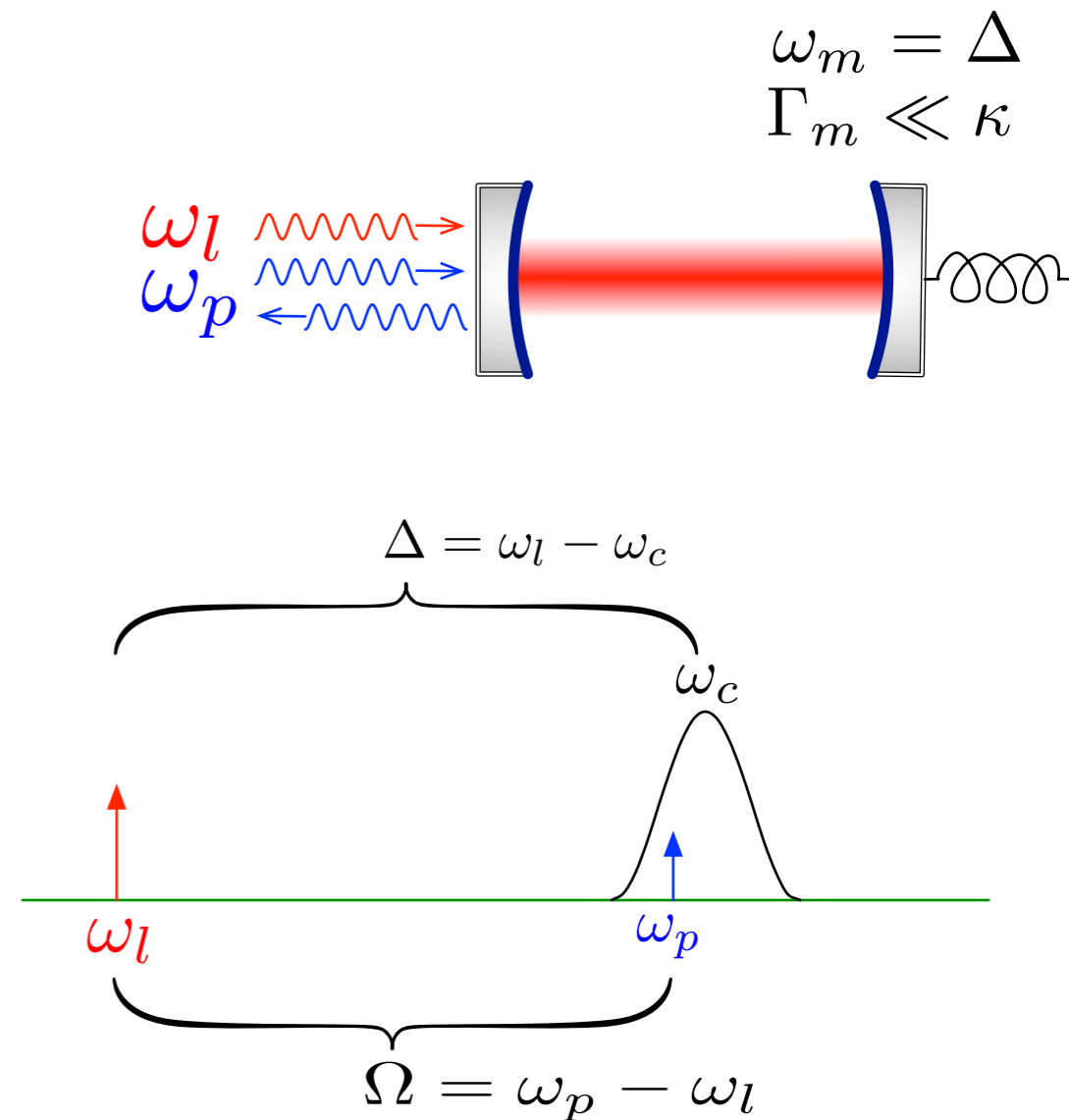
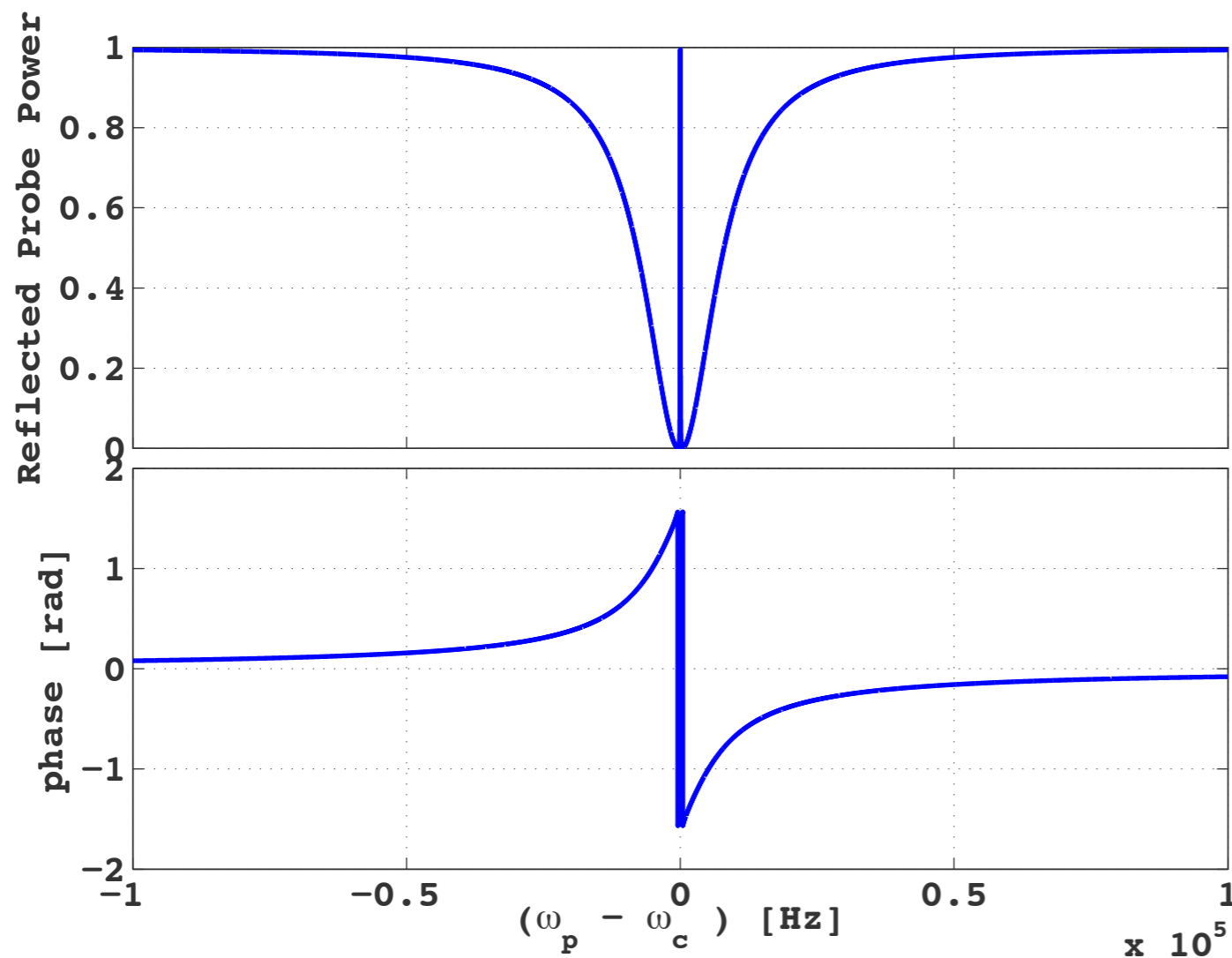

The mirror motion is driven by the beat between the control and probe beams. This motion upconverts control laser light, where it can interfere with the probe beam.

look closer

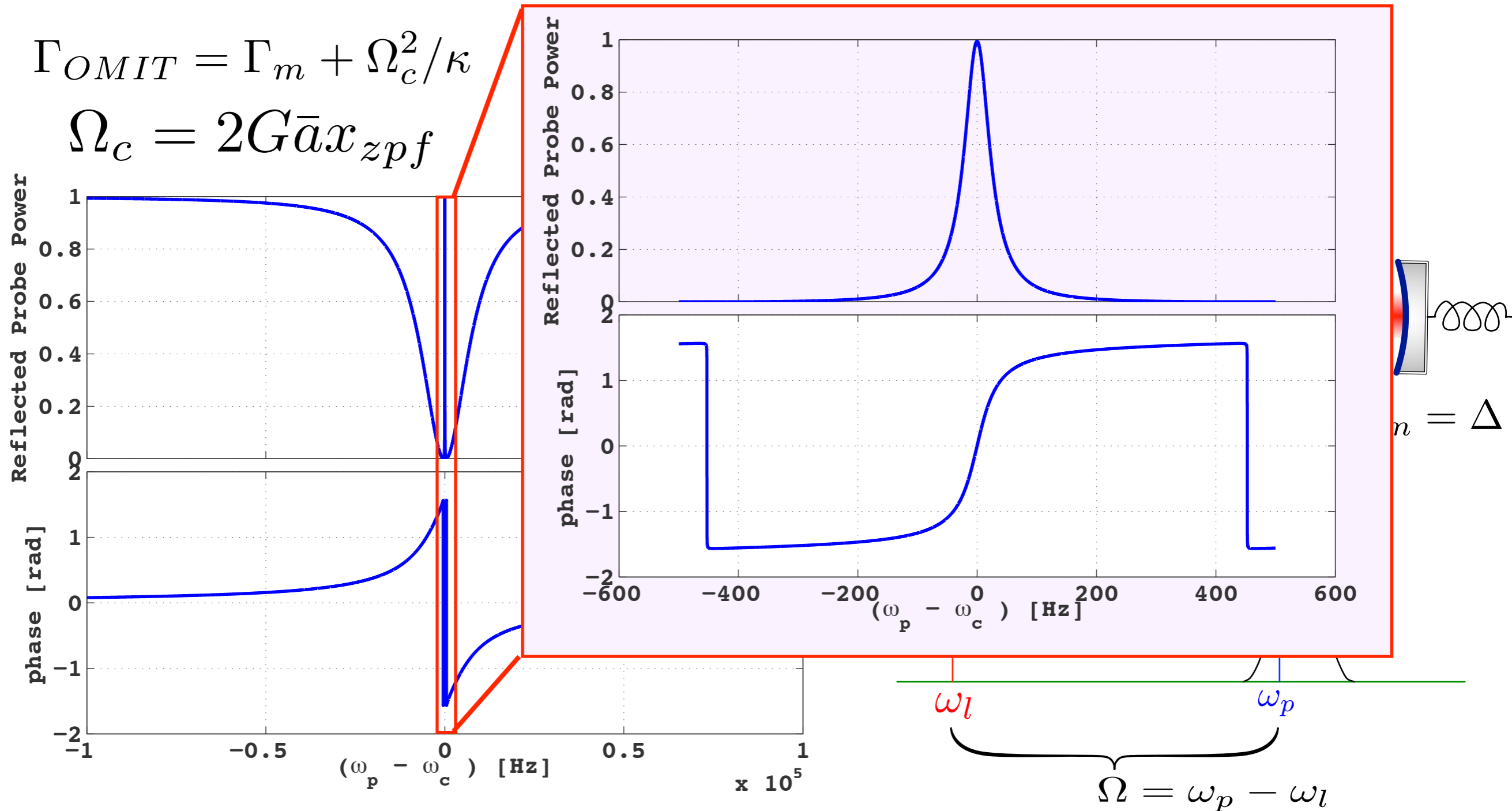

Resonance width depends on mechanical resonance, and optomechanical cooperativity (which depends on optomechanical coupling and in-cavity amplitude).

over-coupled cavity

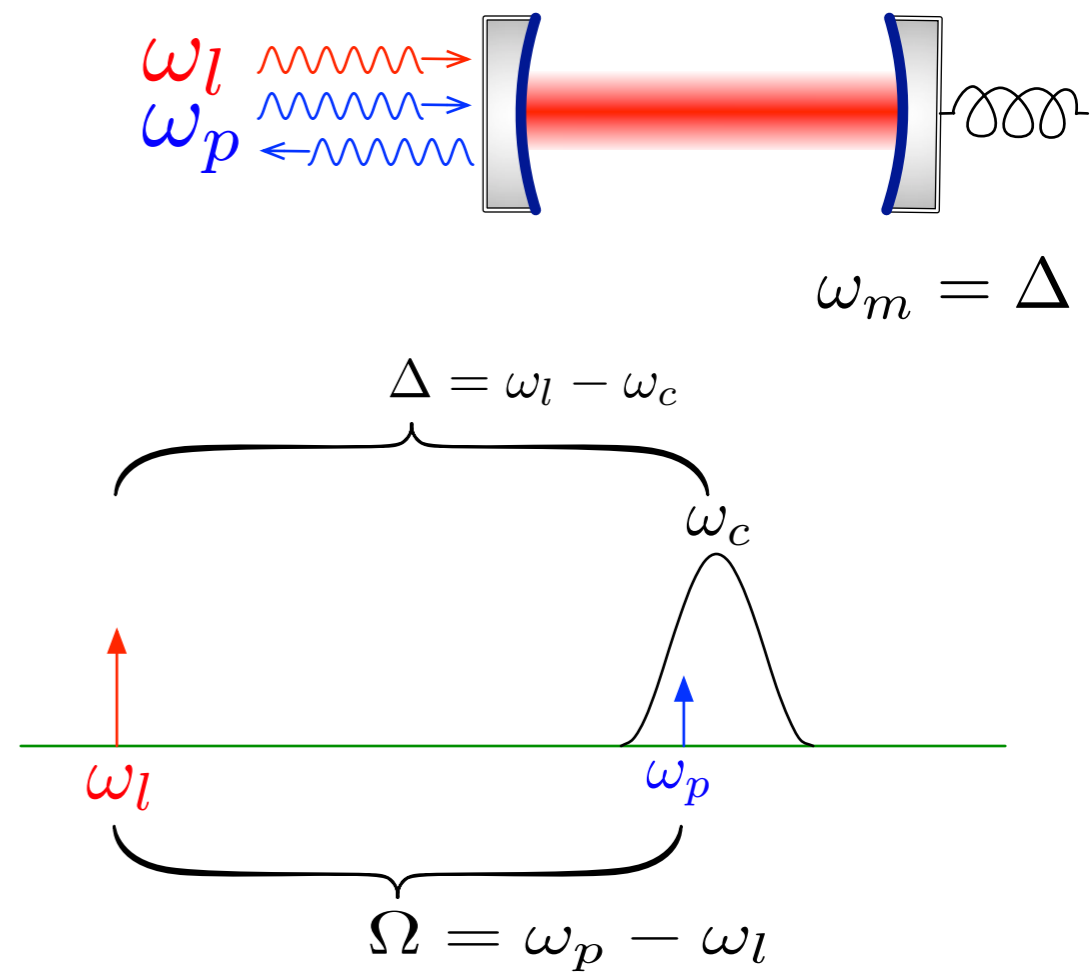
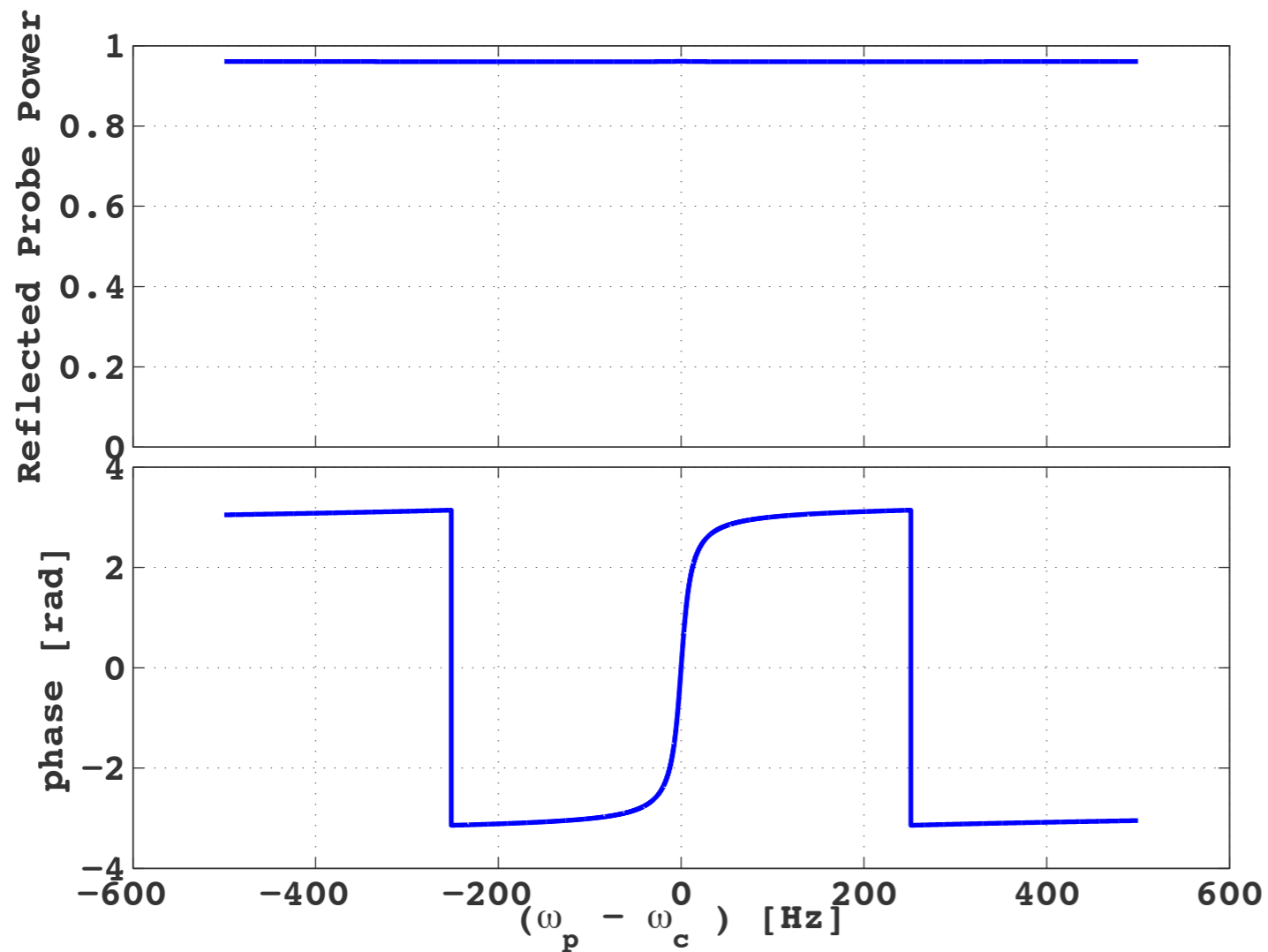

Strongly overcouple the cavity. Still get the phase shift. Looks like a great filter cavity.

parameters

desired width: $\Gamma_{OMIT} = \Gamma_m + \Omega_c^2/\kappa \sim 100\text{Hz}$

cavity linewidth	κ	100 kHz
mech. frequency	ω_m	1 MHz
mech. Q	Q_m	10^6
optomechanical coupling	$\Omega_c = 2G\bar{a}x_{zpf}$	2 kHz

A system with ~these parameters can be realised with commercially available components.

a high finesse system: membrane in the middle

- Use a SiN membrane as mechanical oscillator.
- Cheaply available.
- High Q, resonant frequency (fundamental mode $\sim 300\text{kHz}$ for $1\text{mm} \times 1\text{mm} \times 50\text{nm}$).

$$Q_m = \frac{\omega_m}{\Gamma_m} \sim 10^6$$

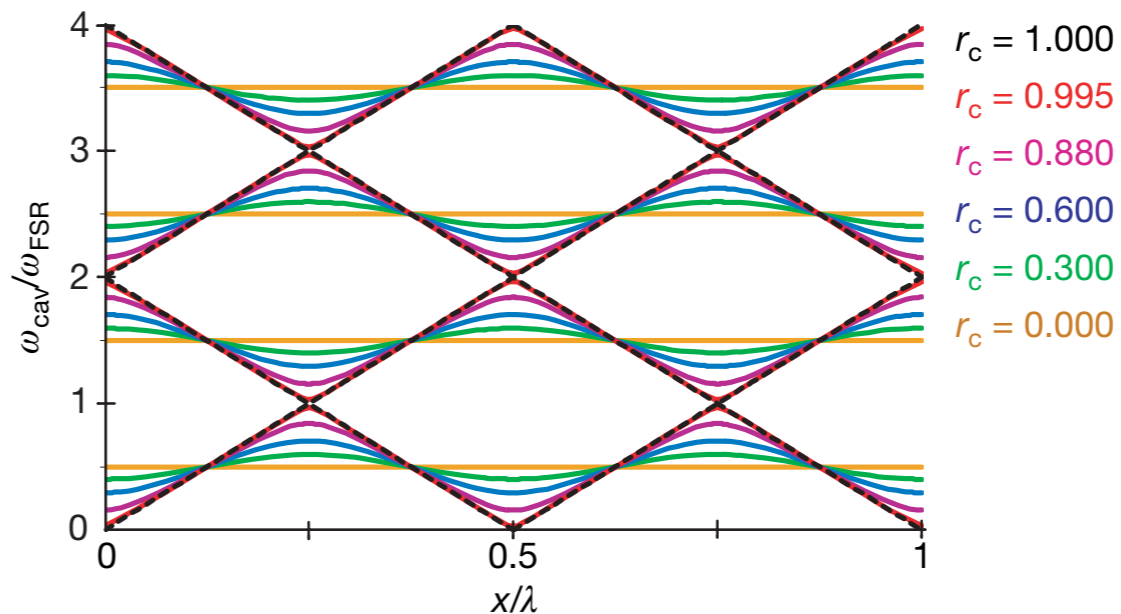
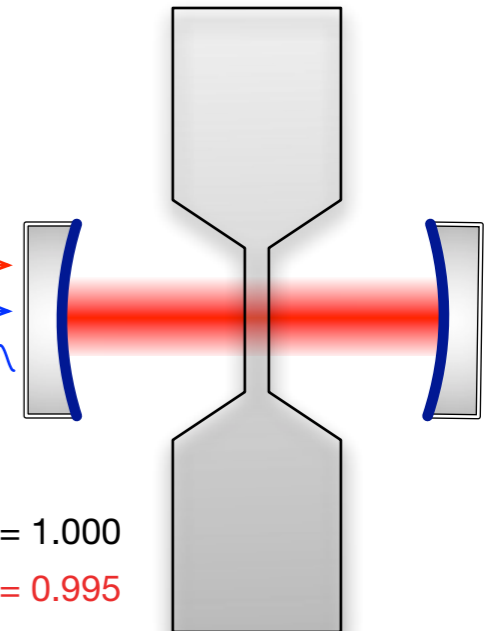
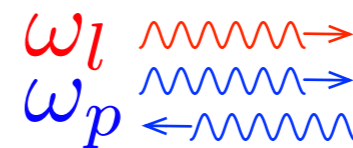
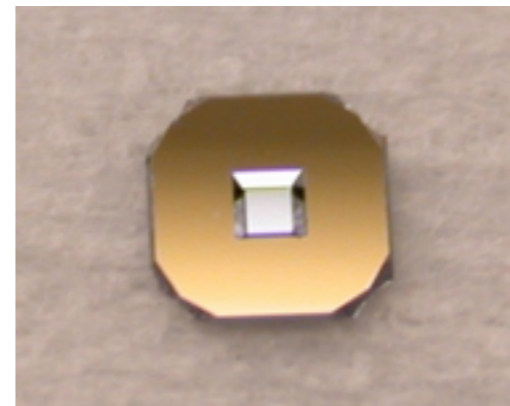

J. D. Thompson, B. M. Zwickl, A. M. Jayich, Florian Marquardt, S. M. Girvin, and J. G. E. Harris.
Strong dispersive coupling of a high-finesse cavity to a micromechanical membrane. *Nature*,
452(7183):72–75, 03 2008.

concept

beam combiner/
separator cavity

$$\kappa \ll \Delta = \omega_m$$

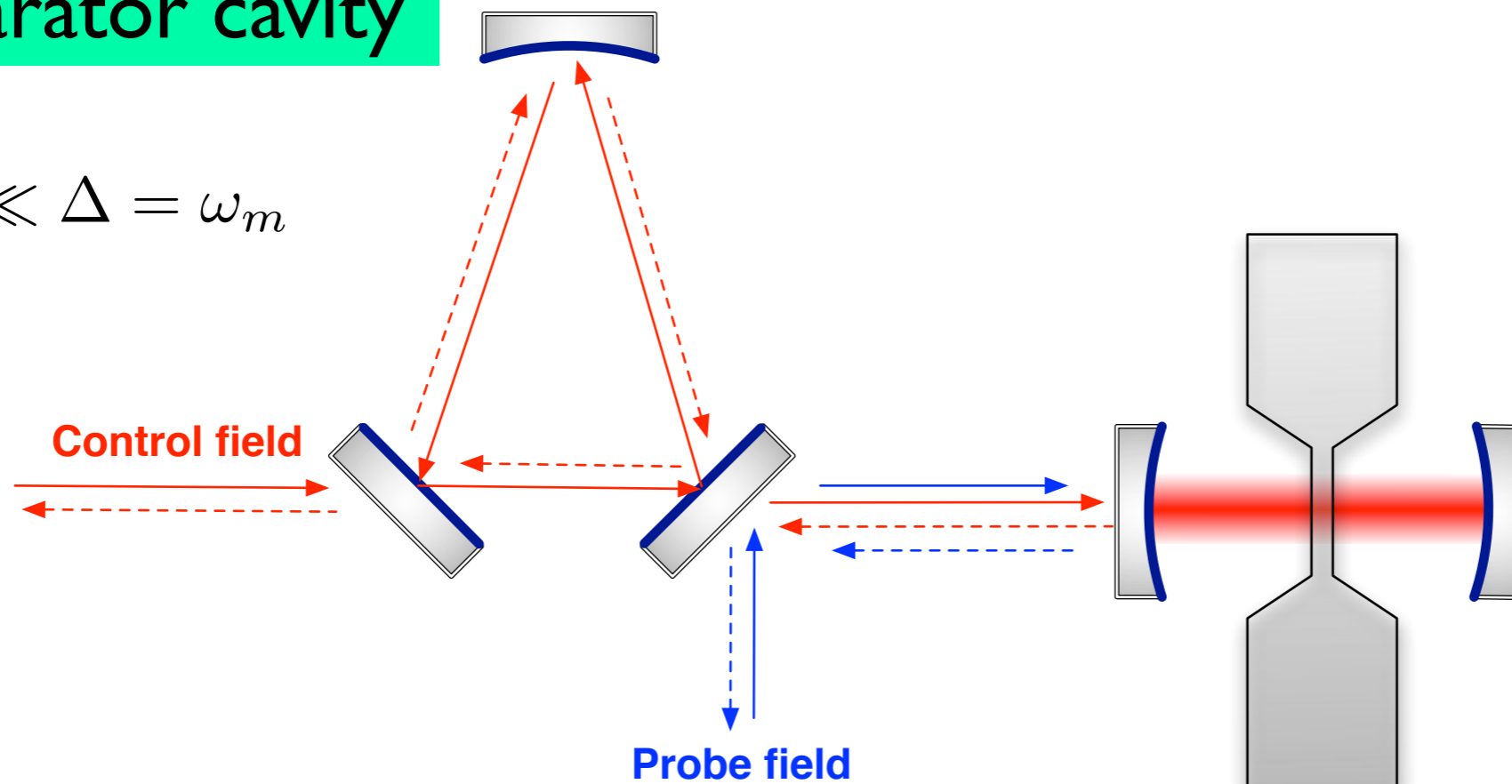

filter cavity

externally generated
squeezed vacuum field

challenges

- Optical losses

- membrane has complex index of refraction; imaginary part $\sim 10^{-4}$
- impact depends on microscopic position (and thus opto-mechanical coupling)

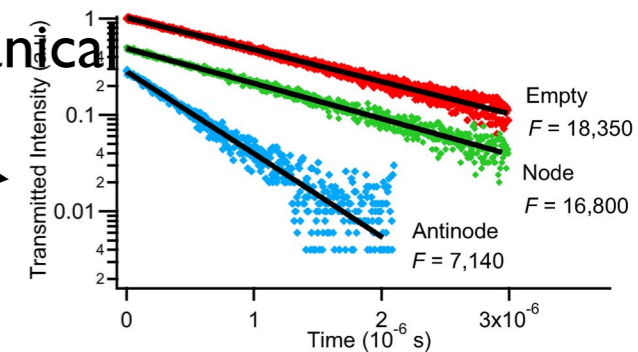

B. M. Zwickl, et al. *Applied Physics Letters*, 92(10):103125, 2008.

- Modal overlap

- membrane acoustic mode not perfectly matched to optical mode
- membrane higher order modes

- Thermal noise

- some form of cooling necessary
- combination of refrigeration and laser cooling (resolved sideband)
- more on this from Zach coming up next!

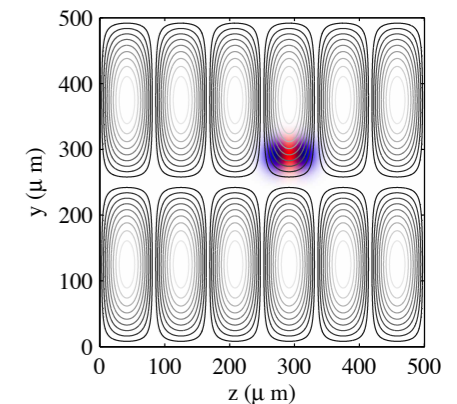

Yi Zhao, et al. *Opt. Express*, 20(4):3586–3612, Feb 2012.

laser cooling

- the membrane can theoretically be cooled to the quantum ground state

$$T_{eff} = T \frac{\Gamma_m}{\Gamma_m + \Gamma_{OM}}$$

$$\Gamma_{OM} = 4G^2 x_{zpf}^2 \bar{a} / \kappa$$

recall: $\Omega_c = 2G\bar{a}x_{zpf}$

- laser cooling changes the OMIT linewidth, so cannot rely on it too much

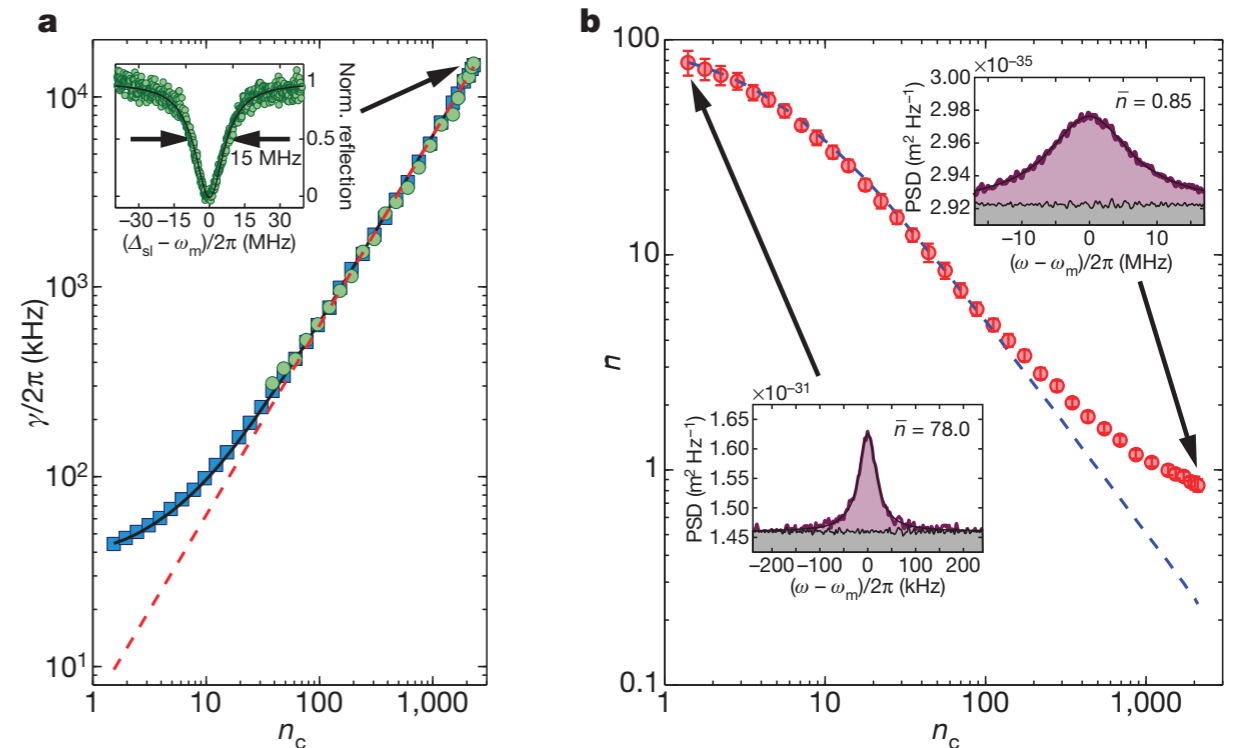

Jasper Chan, T. P. Mayer Alegre, Amir H. Safavi-Naeini, Jeff T. Hill, Alex Krause, Simon Groblacher, Markus Aspelmeyer, and Oskar Painter. Laser cooling of a nanomechanical oscillator into its quantum ground state. *Nature*, 478(7367):89–92, 10 2011.

electro-opto-mechanical

- engineer non-uniform capacitor plates around the membrane.
- Fringing fields creative capacitive sensor/actuator, like ESD in aLIGO.
- Couple mechanical system to electronic oscillator --> modify mechanical susceptibility.
- Use an electronic oscillator rather than mechanical oscillator.
 - thermal noise?
- Capacitive coupler never been done
 - requires \sim um size electrode gap
- other actuator/sensor systems possible (e.g., second laser)

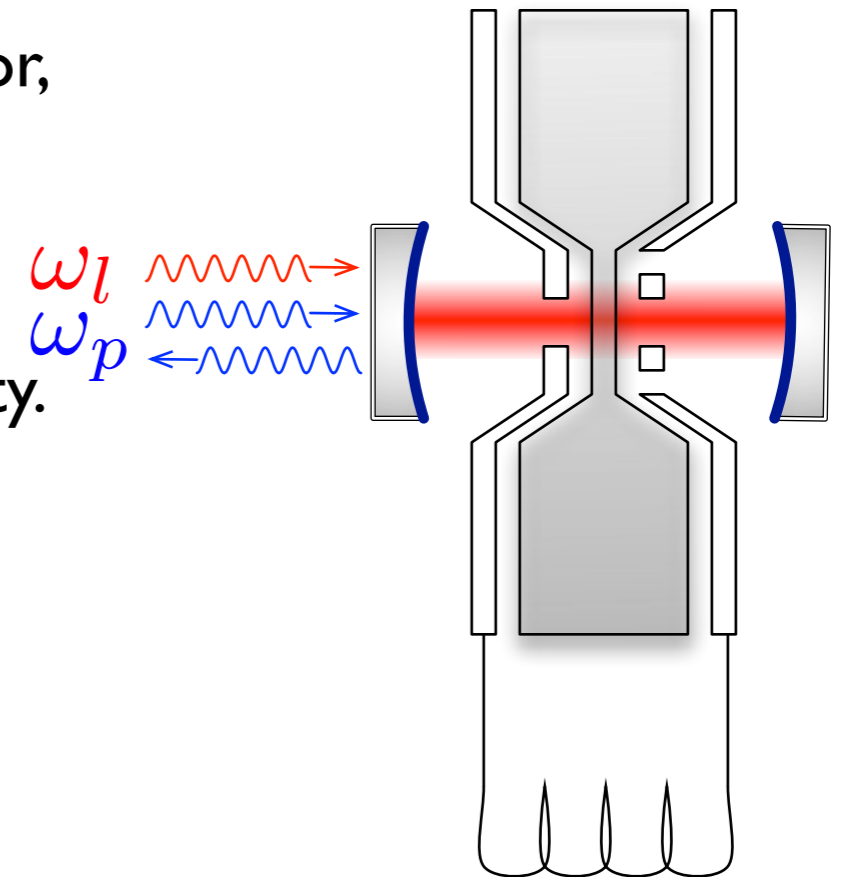

J. M. Taylor, A. S. Sørensen, C. M. Marcus, and E. S. Polzik. Laser cooling and optical detection of excitations in a *lc* electrical circuit. *Phys. Rev. Lett.*, 107:273601, Dec 2011.

and someone's already built something like it

- A fiber-coupled system on a chip, with a Si disk resonator evanescently coupled to a SiN ring, with electronic actuation. Batch processible.
- Oscillator f , Q , too low, and fibers are lossy.

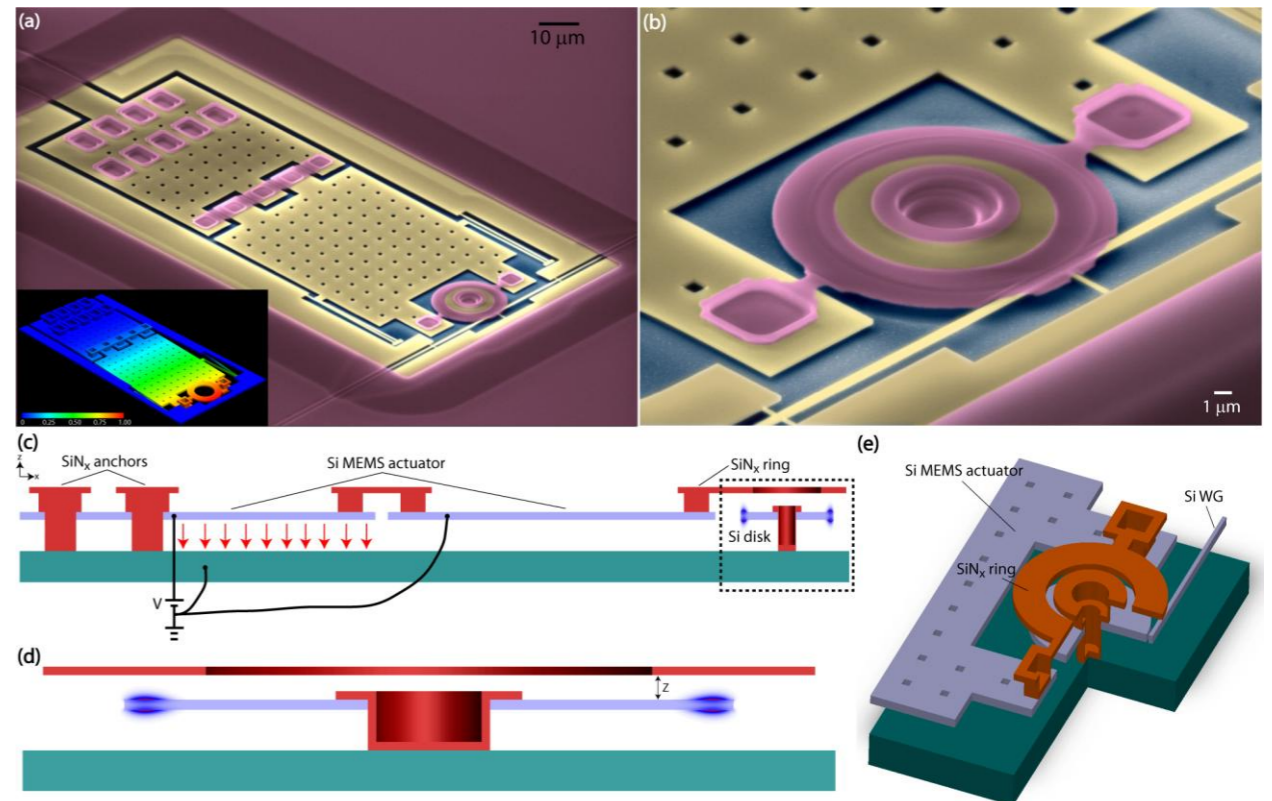

H. Miao, K. Srinivasan, and V. Aksyuk.

A microelectromechanically controlled cavity optomechanical sensing system.
ArXiv e-prints, April 2012.

