

NOTES CONTINUED:
⑤

REV.	DATE	DCN #	DRAWING TREE #
v1	30 JUN 2012	-	-
v2	29 NOV 2012	-	-
-	-	-	-

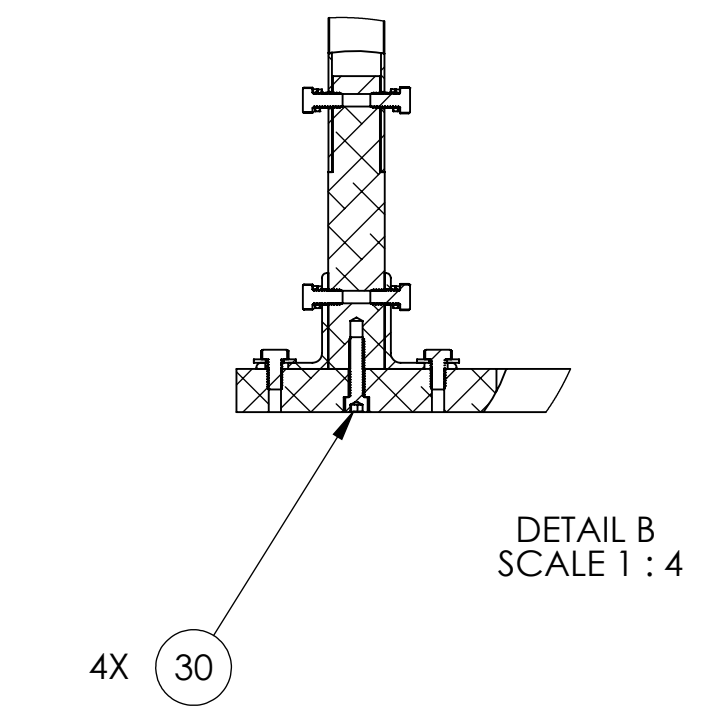
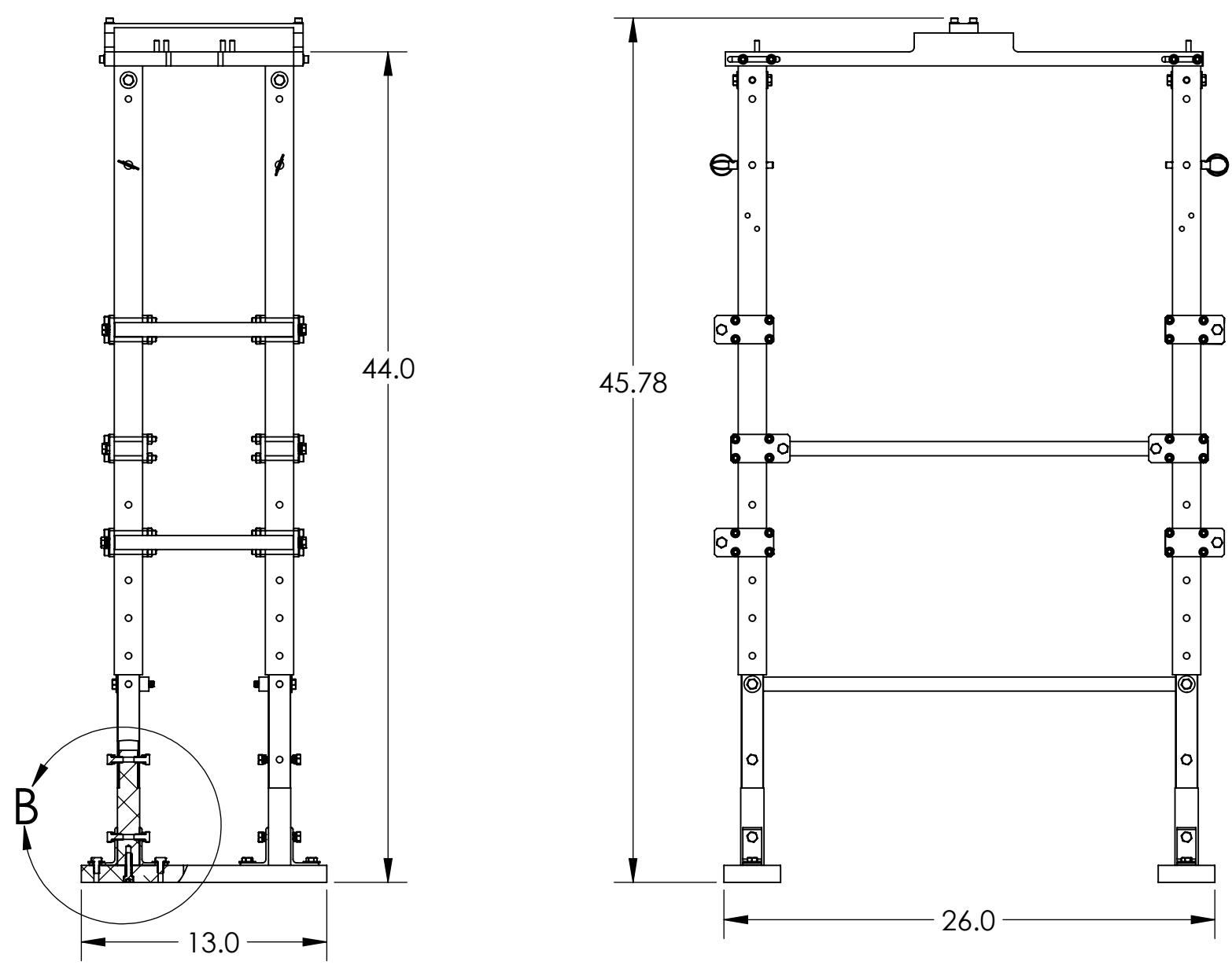
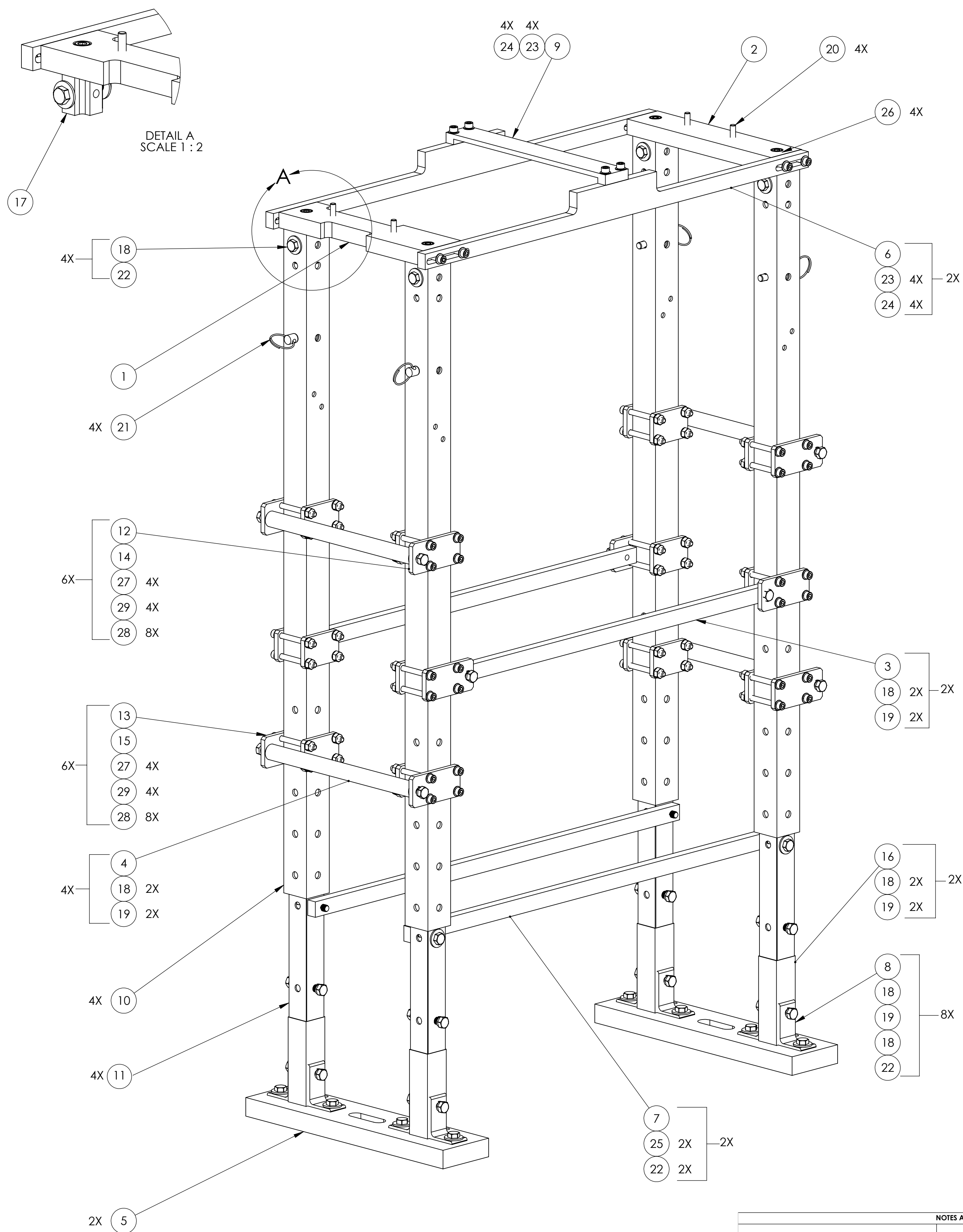

ITEM NO.	PART NUMBER	DESCRIPTION	MATERIAL	QTY.	TOTAL
30	92200A632	Socket Head Cap Screw_5/16-18 X 1.25 L	18-8 SSSL	4	0
29	N-2520-A	HEX NUT 1/4-20	Ag-PLATED 300 SSSL	48	0
28	WF-25	FLAT WASHER 1/4 SCREW SIZE	18-8 SSSL	96	0
27	92185A555	Screw, socket head cap 1/4-20 X 2.5" L	316 SSSL	48	0
26	92200A626	SOCKET HEAD CAP SCREW_5/16-18 X 3/4" L	18-8 SSSL	4	0
25	92245A591	SS HEX HEAD CAP SCREW-5/16-18, 2.0 L	18-8 SSSL	4	0
24	90313A203	FLAT WASHER 1/4 SCREW SIZE	18-8 SSSL	12	0
23	92200A541	SOCKET HEAD CAP SCREW, SHC, 1/4-20 x 7/8" L	18-8 SSSL	12	0
22	98370A015	WASHER 5/16 SCREW	18-8 SSSL	20	0
21	95165A054	QUICK-RELEASE PIN	18-8 SSSL	4	0
20	90145A542	1/4" DOWEL PIN	18-8 SSSL	4	0
19	98437A112	SPRING LOCK WASHER	18-8 SSSL	28	0
18	92245A580	HEX HEAD CAP SCREW-5/16-18 x 5/8 L	18-8 SSSL	44	0
17	D1102348	HIDDEN CONNECTOR	6061-T6 Al	4	0
16	D1200586	LIFT STAND EXTENSION TUBE	6061-T6 Al	4	0
15	D1102224-02	HANDLE TAB CLAMP-LEFT BOSS	6061-T6 Al	6	0
14	D1102224-01	HANDLE TAB CLAMP-RIGHT BOSS	6061-T6 Al	6	0
13	D1102223-02	HANDLE TAB-LEFT BOSS	6061-T6 Al	6	0
12	D1102223-01	HANDLE TAB-RIGHT BOSS	6061-T6 Al	6	0
11	D1102144-02	ALUMINUM RAIL TUBE	6061-T6 Al	4	0
10	D1102144-01	ALUMINUM TELESCOPE TUBE	6061-T6 Al	4	0
9	D1200593	ITM ELLIPTICAL X_TOP CLAMP	6061-T6 Al	1	0
8	D1102039	ANGLE CORNER BRACKET	6061-T6 Al	8	0
7	D1102038	LOWER SIDE BRACE	6061-T6 Al	2	0
6	D1102026	SIDE BEAM	6061-T6 Al	2	0
5	D1102024	FLOOR-MOUNTING BASE	6061-T6 Al	2	0
4	D1102023	ROUND BAR HANDLE	6061-T6 Al	4	0
3	D1102022	SIDE BRACE	6061-T6 Al	2	0
2	D1200588	ITM ELLIPTICAL BAFFLE, END BLOCK SUPPORT	6061-T6 Al	1	0
1	D1200587	ITM ELLIPTICAL BAFFLE, GUIDE BLOCK SUPPORT	6061-T6 Al	1	0
ITEM NO.	PART NUMBER	DESCRIPTION	MATERIAL	D1200581-No suspension/QTY. TOTAL	

NOTES AND TOLERANCES: (UNLESS OTHERWISE SPECIFIED)

DIMENSIONS ARE IN INCHES	
TOLERANCES: .XX ± .02 .XXX ± .010	
ANGULAR ± 1.0°	
1. APPROXIMATELY WEIGHT = 39.0 LBS	2. TORQUE SHCS TO VALUES SPECIFIED IN LIGO-T1100066.
MATERIAL	FINISH
N/A	N/A μinch

LIGO CALIFORNIA INSTITUTE OF TECHNOLOGY MASSACHUSETTS INSTITUTE OF TECHNOLOGY

ADVANCED LIGO AOS

PART NAME
ITM ELLIPTICAL BAFFLE_SUSPENSION LIFT STAND

DESIGNER	TQ. NGUYEN	12 APR 2012	SIZE	DWG. NO.	REV.
DRAFTER	TQ. NGUYEN	29 JUN 2012	D	D1200581	v2
CHECKER	L. AUSTIN		SCALE: 1:3	PROJECTION:	SHEET 1 OF 3
APPROVAL	M. SMITH				

D1200581_LIGO_ITM_Elliptical_Baffle_Suspension_Lift_Stand_PRT_PDM_REV-X-015_DRAINING_PDM_REV-X-002

8

7

6

5

4

3

2

1

H

G

F

E

D

C

B

A

H

G

F

E

D

C

B

A

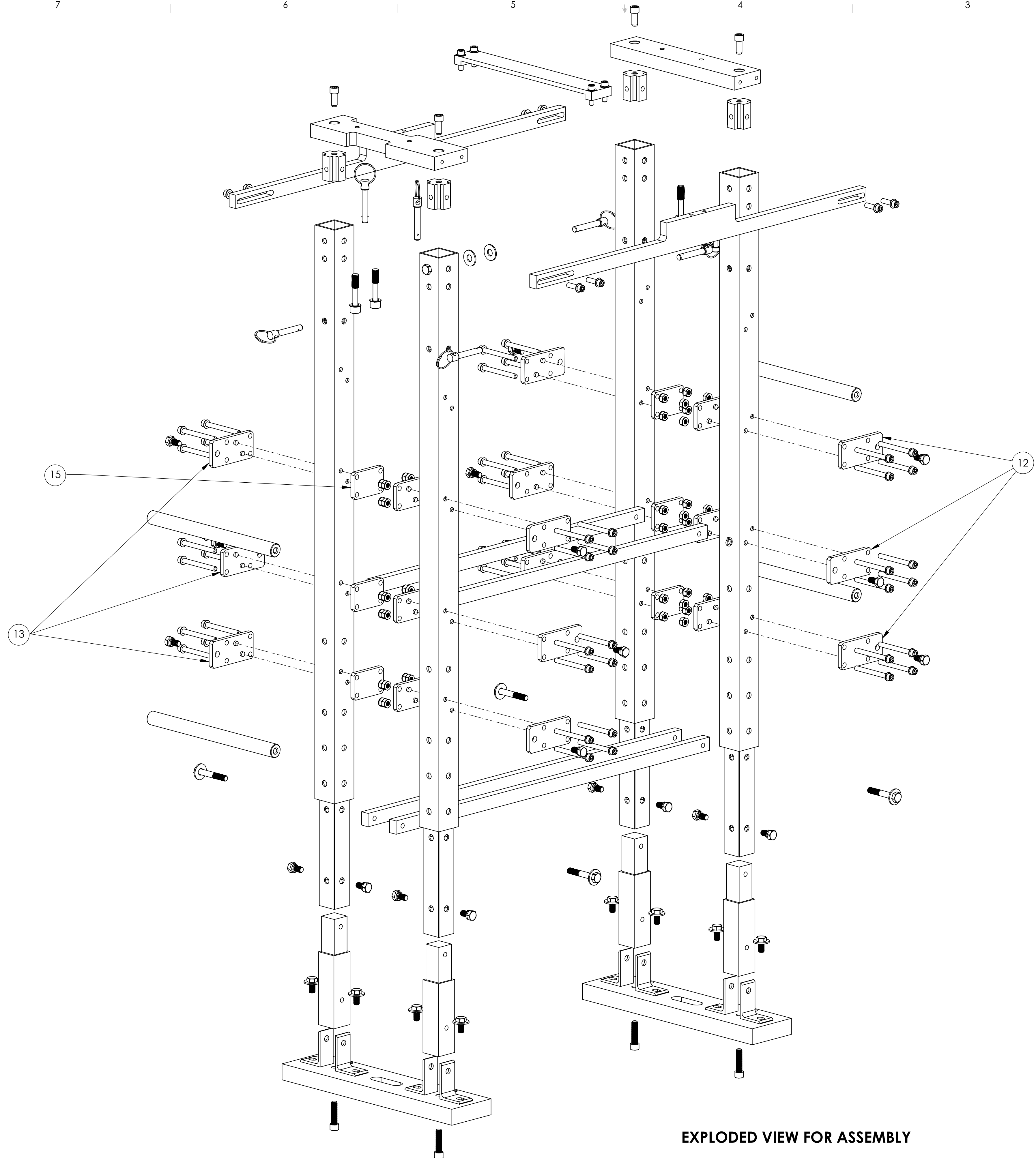

EXPLODED VIEW FOR ASSEMBLY

 CALIFORNIA INSTITUTE OF TECHNOLOGY MASSACHUSETTS INSTITUTE OF TECHNOLOGY		REV.
SIZE	DWG. NO.	REV.
D	D1200581	v2
SCALE: 1:12	PROJECTION:	SHEET 2 OF 3

D:\200581_LIGO\JM\Electrical\Baffle_Suspension_Lift_Stand_PART.PDM REV: X-015. DRAWING PDM REV: X-002

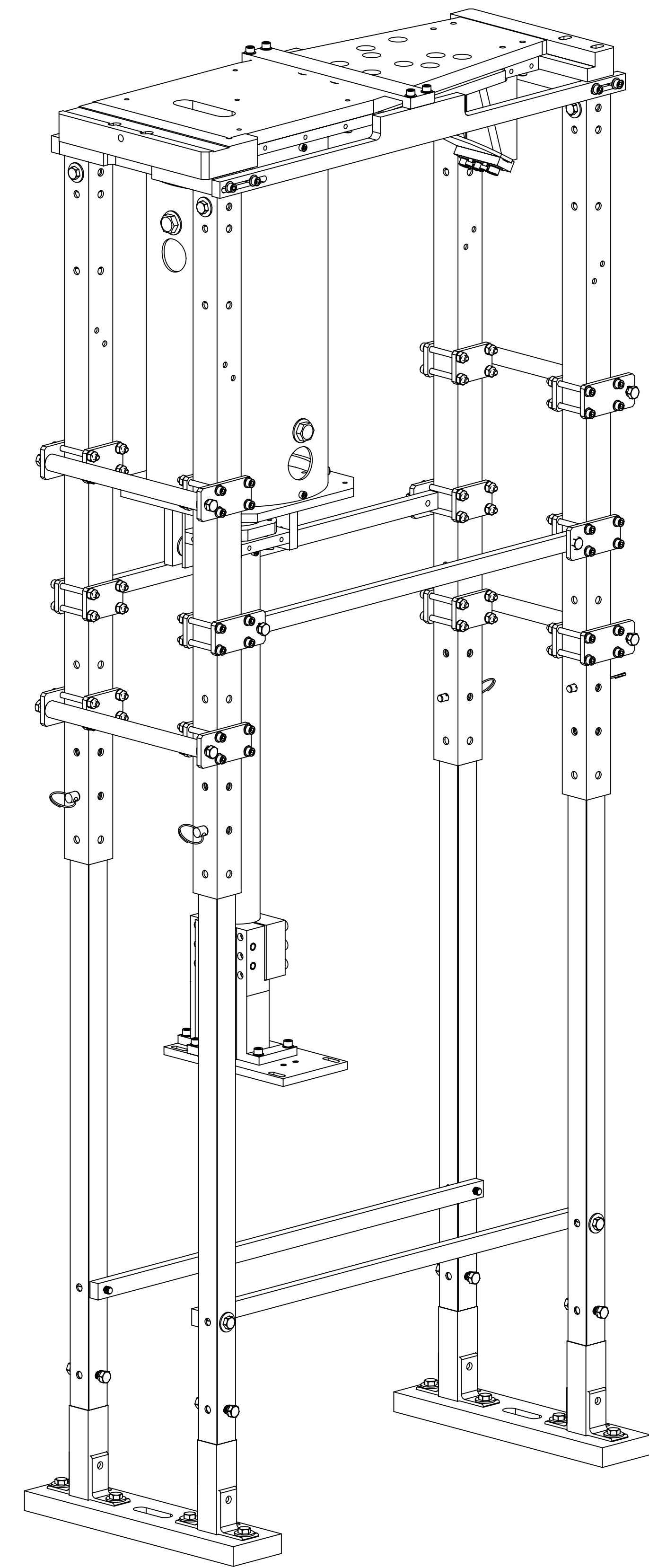
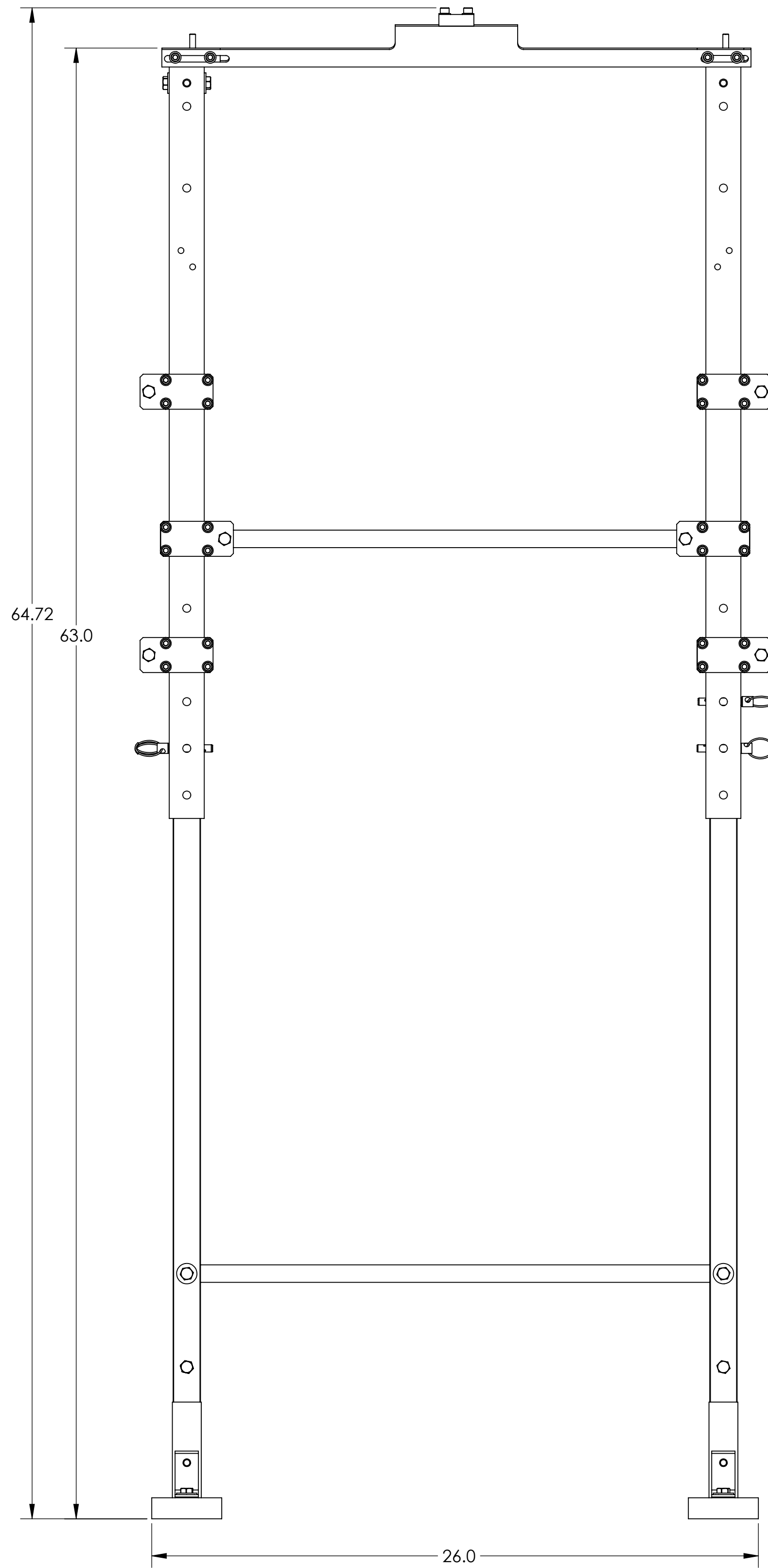
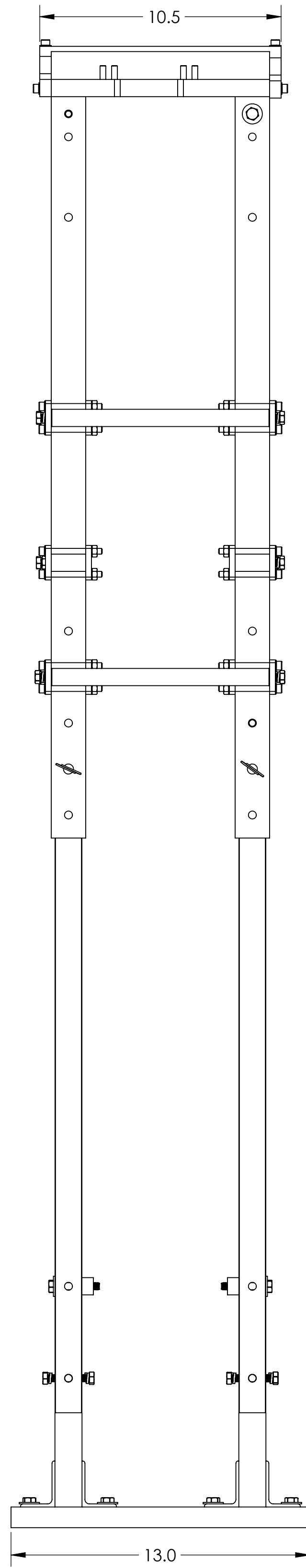

LIFT STAND WITH SUSPENSION

 CALIFORNIA INSTITUTE OF TECHNOLOGY MASSACHUSETTS INSTITUTE OF TECHNOLOGY		SIZE DWG. NO. D D1200581	REV. v2
SCALE: 1:4		PROJECTION: 	SHEET 3 OF 3

D1200581_LIGO_TIM_Electrical Baffle_Suspension Lift Stand PART PDM REV: X-015 DRAWING PDM REV: X-002