

NOTES CONTINUED:

5. SCRIBE, ENGRAVE, LASER MARK OR MECHANICALLY STAMP (NO DYES OR INKS) A UNIQUE THREE DIGIT SERIAL NUMBER & REVISION NUMBER ON EACH PART. SERIAL NUMBERS START AT 001 FOR THE FIRST ARTICLE AND PROCEED CONSECUTIVELY. BAG AND TAG PARTS WITH THEIR DRAWING PART NUMBER, REVISION, VARIANT OR "TYPE" (IF APPLICABLE), AND QUANTITY. IF PARTS ARE TOO SMALL TO SCRIBE, BAGGING AND TAGGING ALONE IS SUFFICIENT.  
 EXAMPLE (PART): 001-v1  
 EXAMPLE (TAG): DXXXXXX-VY, TYPE-XX, QTY: TBD

6. APPROXIMATE WEIGHT = X.XXX LB.

7. MACHINE ALL SURFACES TO REMOVE OXIDES AND MILL FINISH. USE OF ABRASIVE REMOVAL TECHNIQUES IS NOT ALLOWED. REFER TO LIGO-E0900364

8. ALL PARTS SHALL BE MANUFACTURED IN ACCORDANCE WITH LIGO SPECIFICATION E0900364.

11. ALL MATERIAL IS TO BE VIRGIN MATERIAL (i.e. NO WELD REPAIRS, PLUGS OR RECYCLED MATERIAL). NO REPAIRS SHALL BE MADE UNLESS APPROVED IN ADVANCE, AND IN WRITING, BY LIGO LABORATORY. REFER TO LIGO-E0900364.

12. MACHINE FILLET RADII, .015 MAX.

REV.	DATE	DCN #	DRAWING TREE #
v1	29 MAR 2012	E1200307-x0	-
-	-	-	-
-	-	-	-

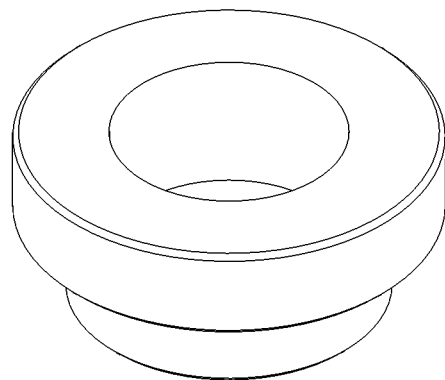

ISO VIEW

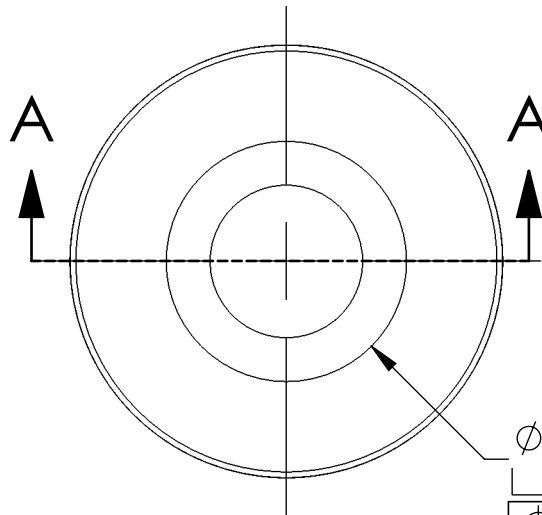

Ø .397 THRU ALL  
 □ Ø .625 ▽ .375  
 ⊕ .010 (M) A B

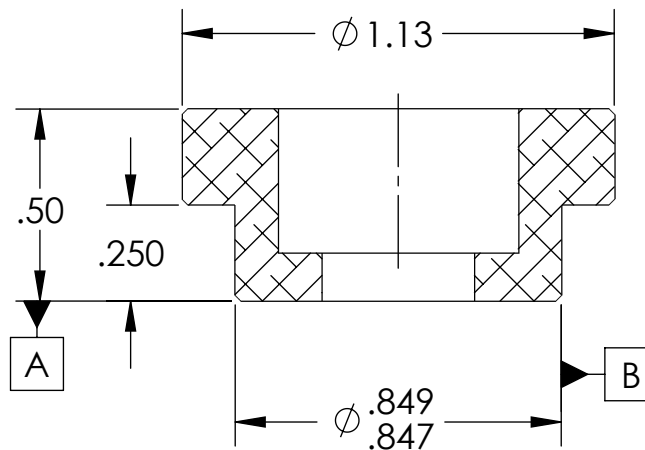

SECTION A-A

NOTES AND TOLERANCES: (UNLESS OTHERWISE SPECIFIED)

DIMENSIONS ARE IN INCHES

TOLERANCES:

.XX ± .01  
.XXX ± .005

ANGULAR ± 0.5°

- INTERPRET DRAWING PER ASME Y14.5-1994.
- REMOVE ALL SHARP EDGES: .005-.015. FOR MACHINED PARTS. ROUND ALL EDGES APPROXIMATELY R.02 FOR SHEET METAL PARTS.
- DO NOT SCALE FROM DRAWING.
- ALL MACHINING FLUIDS MUST BE FULLY SYNTHETIC, FULLY WATER SOLUBLE AND FREE OF SULFUR, SILICONE, AND CHLORINE.

MATERIAL

6061-T6 Al

FINISH

63 μinch



CALIFORNIA INSTITUTE OF TECHNOLOGY  
MASSACHUSETTS INSTITUTE OF TECHNOLOGY

SYSTEM

ADVANCED LIGO

SUB-SYSTEM

COC

NEXT ASSY

D1200490

PART NAME

ALIGO, SUS, QUAD, SPRAY GUARD ASSY., CLAMPING FLANGE

DESIGNER

E.SANCHEZ 16 MAR 2012

DRAFTER

E.SANCHEZ 29 MAR 2012

CHECKER

SEE DCC SEE DCC

APPROVAL

SEE DCC SEE DCC

SIZE

A

DWG. NO.

D1200489

REV.

v1

SCALE: 2:1

PROJECTION:



SHEET 1 OF 1