

STEP	DESCRIPTION	PART#	QTY	TIME
1	Tooling BOLT D1000574 TOOLING TO OPTICS BENCH	SURFACE_TABLE	1	0.08
	Tooling	TD-1084-038	1	
2	ADD BLADE CLAMP HELICOILS	1185-4EN375 1-4.20X1-5D_UNC_THREAD_INSERT	5	
		1185-6EN562 3-8.16X1-5D_UNC_THREAD_INSERT	4	
		D060326-000	1	
3	ASSEMBLE BLADE TO BLADE CLAMP INDEPENDANTLY OF ANT TOOLING	C-1628-NA 3-8.16_UNC_1-75_INCH	2	0.08
		D1100785-562 3-8_INCH_WASHER	2	
		D1200116 D060235	1	
		D060327_000	1	
4	Tooling ADD INTERFACE PIECE TO UNDERSIDE OF CLAMP AND BOLT IN PLACE	92196A632 3-8.16_UNC_2-00INCH	2	0.08
	Tooling	D1100785-562 3-8_INCH_WASHER	2	
	Tooling	D060367	1	
5	Tooling BOLT BLADE CLAMP ASSEMBLY INTO BLADE STREIGHTENING TOOLING	92196A626 3-8.16_UNC_1-25INCH	2	
6	DRAW THE BLADE FLAT	D1200116	1	
7	HELICOIL ROTATIONAL ADJUSTER	1185-4EN375 1-4.20X1-5D_UNC_THREAD_INSERT	1	
		D060330	1	
8	ADD ROTATETIONAL ADJUSTMENT PLATE, AND BOLT IN PLACE	C-2016-NA 1-4.20_UNC_1-00INCH	5	0.08
9	HELICOIL BACKBONE	1185-6EN562 3-8.16X1-5D_UNC_THREAD_INSERT	1	
		D060329	1	
10	HELICOIL ROTATIONAL ADJUSTER BRACKET	1185-4EN375 1-4.20X1-5D_UNC_THREAD_INSERT	1	
		D060325	1	
11	ADD BLADE TIP STOP AND ROTATIONAL ADJUSTER BRACKET TO TS STIFF BACK	C-2020-N 1-4.20_UNC_1-25INCH	2	0.08
		D060331	1	
12	Tooling ASSEMBLE BACKBONE TO THE REST OF THE BLADE CARTRIDGE	C-1648-NA 3-8.16_UNC_3-00INCH	2	
13	Tooling ADD TEMPORARY CLAMP	92196A638 3-8.16_UNC_3-5INCH	2	0.08
	Tooling	D060368	1	
14	Tooling REMOVE BLADE CARTRIDGE FROM TOOLING	92196A626 3-8.16_UNC_1-25INCH	2	0.08
15	HELICOIL TEE-NUTS	1185-6EN375 3-8.16X1D_UNC_THREAD_INSERT	2	
		D060328	2	

16	BOLT TS ASSEMBLY TOGETHER WITH CAP SCREWS AND TEE-NUTS	C-1648-NA	3-8.16_UNC_3-00INCH	2	0.08
17	Tooling REMOVE REMAINING TOOLING	C-1648-NA	3-8.16_UNC_3-00INCH	2	0.08
	Tooling	92196A638	3-8.16_UNC_3-5INCH	2	
	Tooling		D060367	1	
	Tooling		D060368	1	
18	ADD ROTATIONAL ADJUSTER SCREWS	D1101960	1-4.20_UNC_1-00INCH_ROUND_	1	0.08
		C-2024-NA	1-4.20_UNC_1-5INCH	1	

NOTES: (UNLESS OTHERWISE SPECIFIED)

1. **Use D060370 - Top Stage Blade Tooling Fixture**

PROCESS PLAN TO BE USED FOR ASSEMBLY ONLY		NOT TO BE USED FOR MANUFACTURE	
NAME	DATE	SYSTEM	aLIGO
DRAWN	J O'DELL 17/MAR/10	SUB-SYSTEM	SUS
CHECKED	J O'D 18/MAR/10	NEXT ASSY	QUAD
APPROVED	JOD 18/MAR/10	PART NAME	TS ASSEMBLY PROCEDURE QUAD TS AND TOOLING
SIZE	B	DRG. NO.	D060370_ASM_PROCEDURE
SCALE	1:1	PROJECTION	1ST ANGLE
		SHEET	1 OF 1

CALIFORNIA INSTITUTE OF TECHNOLOGY
 MASSACHUSETTS INSTITUTE OF TECHNOLOGY
 IGR, GLASGOW UNIVERSITY GEO 600 GROUP
 RUTHERFORD APPLETON LABORATORIES

1

2

HEX L WRENCH SIZE: 3/16
TORQUE 10LB FT

WARNING

A DANGEROUS LEVEL OF ENERGY IS STORED IN THE BLADE THROUGH MOST OF THIS PROCEDURE, GIVING IT THE POTENTIAL TO CAUSE SEIOUS INJURY. TO AVOID INJURY, THE ASSEMBLY INSTRUCTIONS SHOULD BE FOLLWED EXACTLY THROUGHOUT THE PROCEDURE!

NOTE:

START WITH ASSEMBLY D1000574
BOLT D1000574 TOOLING TO OPTICS BENCH
USING SCREWS SHOWN IN THIS VIEW

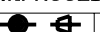
1	SURFACE TABLE	1												
2	TD-1084-038	STREIGHTENING ASSEMBLY												
No.	PART NUMBER	PART DESCRIPTION												
NOTES: (UNLESS OTHERWISE SPECIFIED)														
1.	PROCESS PLAN TO BE USED FOR ASSEMBLY ONLY NOT TO BE USED FOR MANUFACTURE	 CALIFORNIA INSTITUTE OF TECHNOLOGY MASSACHUSETTS INSTITUTE OF TECHNOLOGY 1GR, GLASGOW UNIVERSITY GEO 600 GROUP RUTHERFORD APPLETON LABORATORIES SYSTEM aLIGO SUB-SYSTEM SUS NEXT ASSY QUAD PART NAME TS ASSEMBLY PROCEDURE QUAD TS AND TOOLING												
	<table border="1"> <tr> <td></td> <td>NAME</td> <td>DATE</td> </tr> <tr> <td>DRAWN</td> <td>J O'DELL</td> <td>02/11/09</td> </tr> <tr> <td>CHECKED</td> <td>J'OD</td> <td>18/MAR/10</td> </tr> <tr> <td>APPROVED</td> <td>JOD</td> <td>18/MAR/10</td> </tr> </table>		NAME	DATE	DRAWN	J O'DELL	02/11/09	CHECKED	J'OD	18/MAR/10	APPROVED	JOD	18/MAR/10	SCALE 1:5 PROJECTION:  SHEET 2 OF 1
	NAME	DATE												
DRAWN	J O'DELL	02/11/09												
CHECKED	J'OD	18/MAR/10												
APPROVED	JOD	18/MAR/10												
	DRG. NO. D060370_ASM_PROCEDURE SIZE B	REV A.												

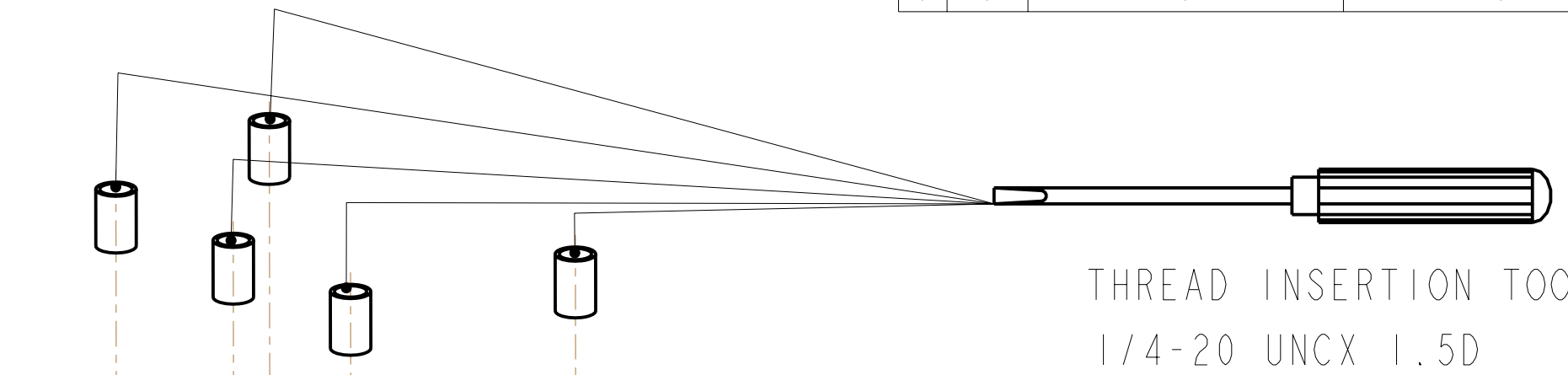

VIEW ON UNDER SIDE OF CLAMP
(ENGRAVING SHOULD BE UPSIDE DOWN)

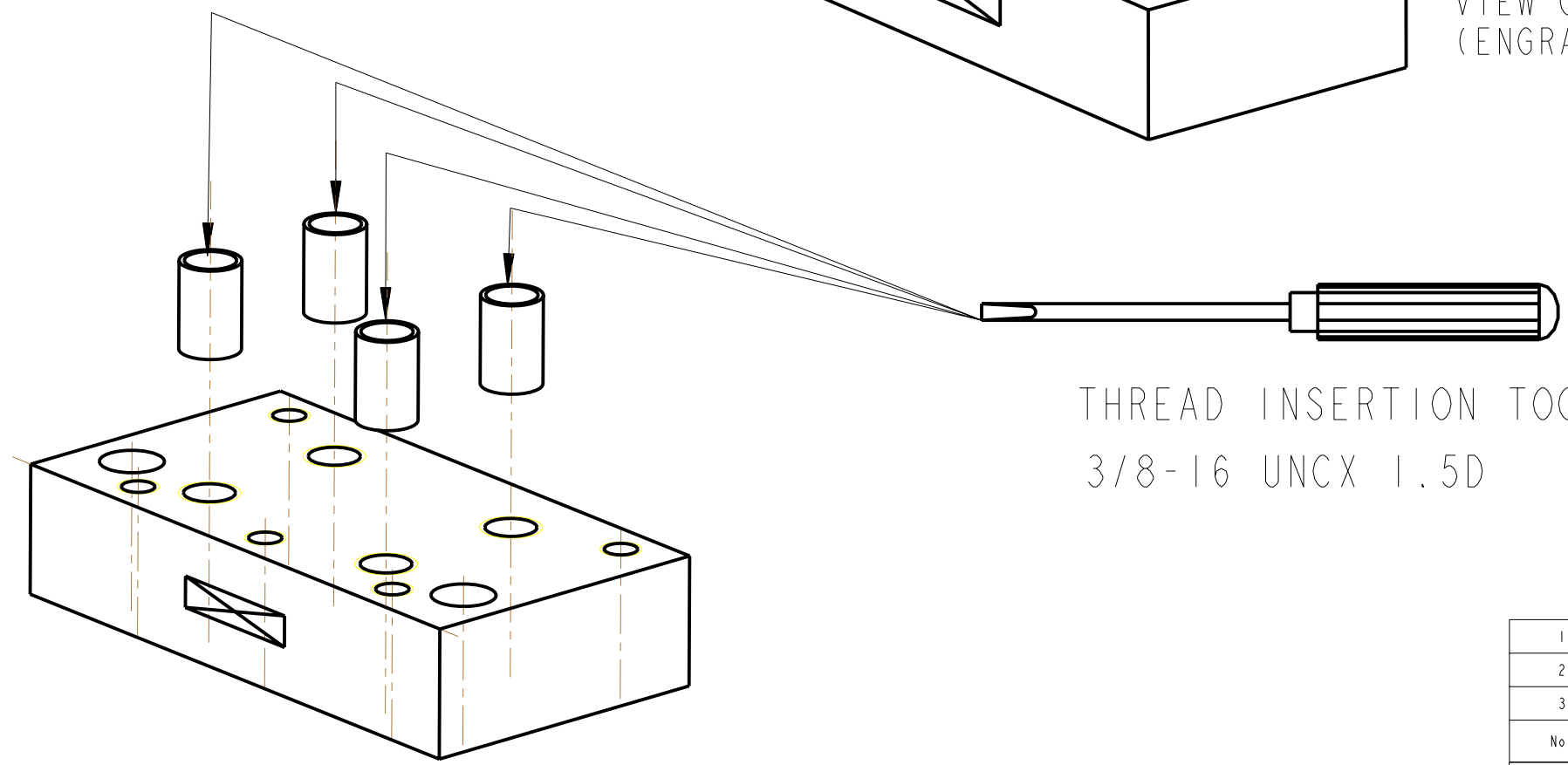

ADD BLADE CLAMP HELICOILS

VIEW ON TOP SIDE OF CLAMP

No.	PART NUMBER	PART DESCRIPTION	NO. REOD
1	1-4_20X1-5D_UNC_THREAD_INSERT	1/4-20 x 1.5D UNC THREAD INSERT	5
2	3-8_16X1-5D_UNC_THREAD_INSERT	3/8-16 x 1.5D UNC THREAD INSERT	4
3	D060326-000	BLADE CLAMP	1

NOTES: (UNLESS OTHERWISE SPECIFIED)

1. PROCESS PLAN TO BE USED FOR ASSEMBLY ONLY NOT TO BE USED FOR MANUFACTURE

NAME	DATE
DRAWN J O'DELL	10/11/09
CHECKED J'OD	18/MAR/10
APPROVED JOD	18/MAR/10

SYSTEM	aLIGO
SUB-SYSTEM	SUS
NEXT ASSY	QUAD
PART NAME	TS ASSEMBLY PROCEDURE QUAD TS AND TOOLING

SCALE	1:1	PROJECTION	AS	SHEET	3 OF 1
-------	-----	------------	----	-------	--------

CALIFORNIA INSTITUTE OF TECHNOLOGY
MASSACHUSETTS INSTITUTE OF TECHNOLOGY
IGR, GLASGOW UNIVERSITY GEO 600 GROUP
RUTHERFORD APPLETON LABORATORIES

DRG. NO. D060370_ASM_PROCEDURE
REV. A.

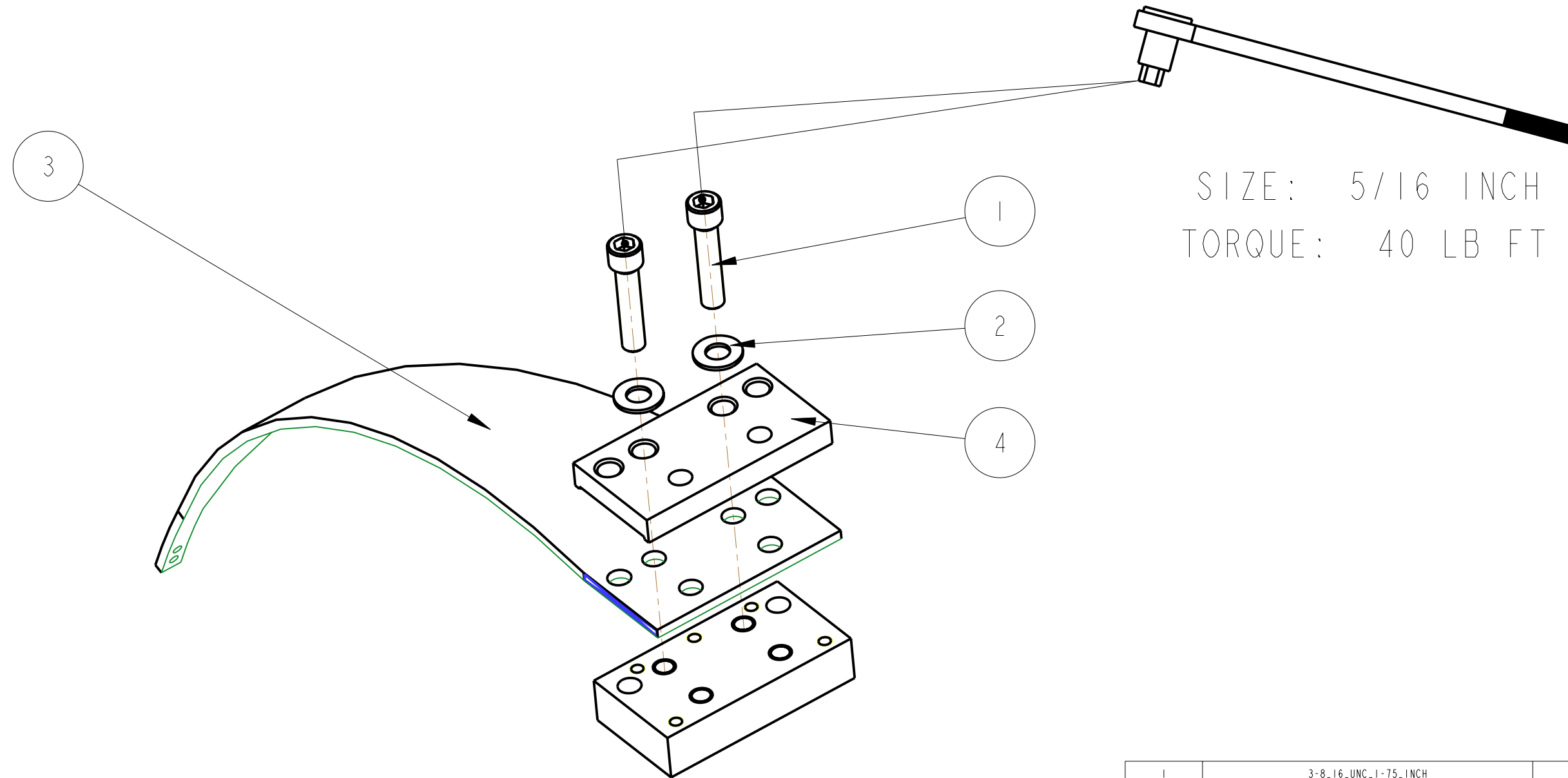

SIZE: 5/16 INCH
TORQUE: 40 LB FT

ASSEMBLE BLADE TO BLADE CLAMP INDEPENDANTLY OF ANT TOOLING

1	3-8_16 UNC_1-75_1 INCH	3/8-16 UNC X 1.75" CAP HEAD	2
2	3-8_1 INCH_WASHER	NITRONIC 60	2
3	D1200116	TOP STAGE BLADES	1
4	D060327_000	BLADE CLAMP	1
No.	PART NUMBER	PART DESCRIPTION	NO. REOD

NOTES: (UNLESS OTHERWISE SPECIFIED)

1. PROCESS PLAN TO BE USED FOR ASSEMBLY ONLY NOT TO BE USED FOR MANUFACTURE

SYSTEM	aLIGO
SUB-SYSTEM	SUS
NEXT ASSY	QUAD
PART NAME	TS ASSEMBLY PROCEDURE QUAD TS AND TOOLING

DRAWN	J O'DELL	02/11/09
CHECKED	J'OD	18/MAR/10
APPROVED	JOD	18/MAR/10

SCALE 1:2 PROJECTION: SHEET 4 OF 1

LIGO CALIFORNIA INSTITUTE OF TECHNOLOGY
MASSACHUSETTS INSTITUTE OF TECHNOLOGY
1GR, GLASGOW UNIVERSITY GEO 600 GROUP
RUTHERFORD APPLETON LABORATORIES

DRG. NO. **D060370_ASM_PROCEDURE** REV. **A.**

REV.	DATE	DCN #	DRAWING TREE #

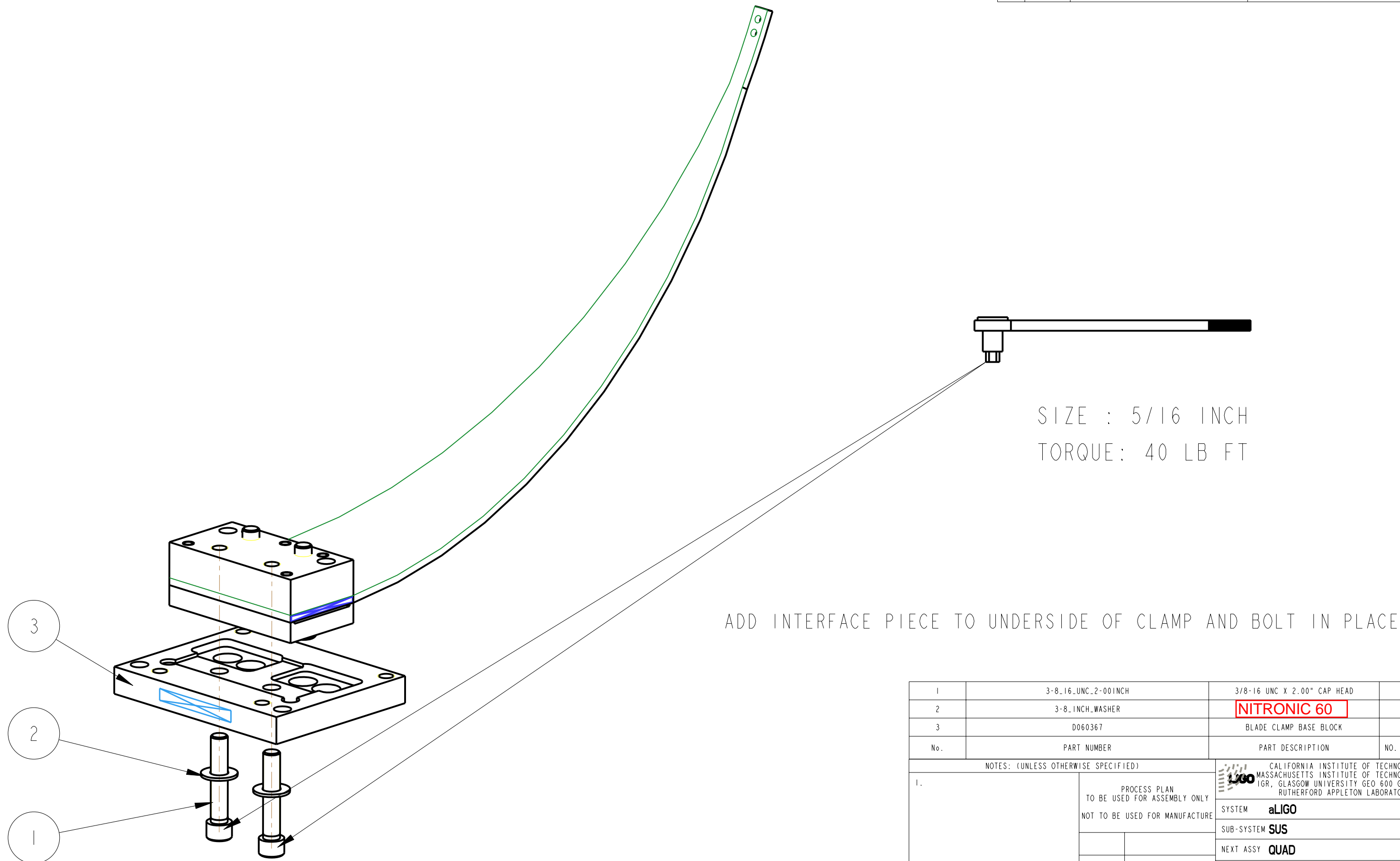

No.	PART NUMBER	PART DESCRIPTION	NO. REOD
1	3-8_16 UNC_2-00 INCH	3/8-16 UNC X 2.00" CAP HEAD	2
2	3-8_1 INCH_WASHER	NITRONIC 60	2
3	D060367	BLADE CLAMP BASE BLOCK	1

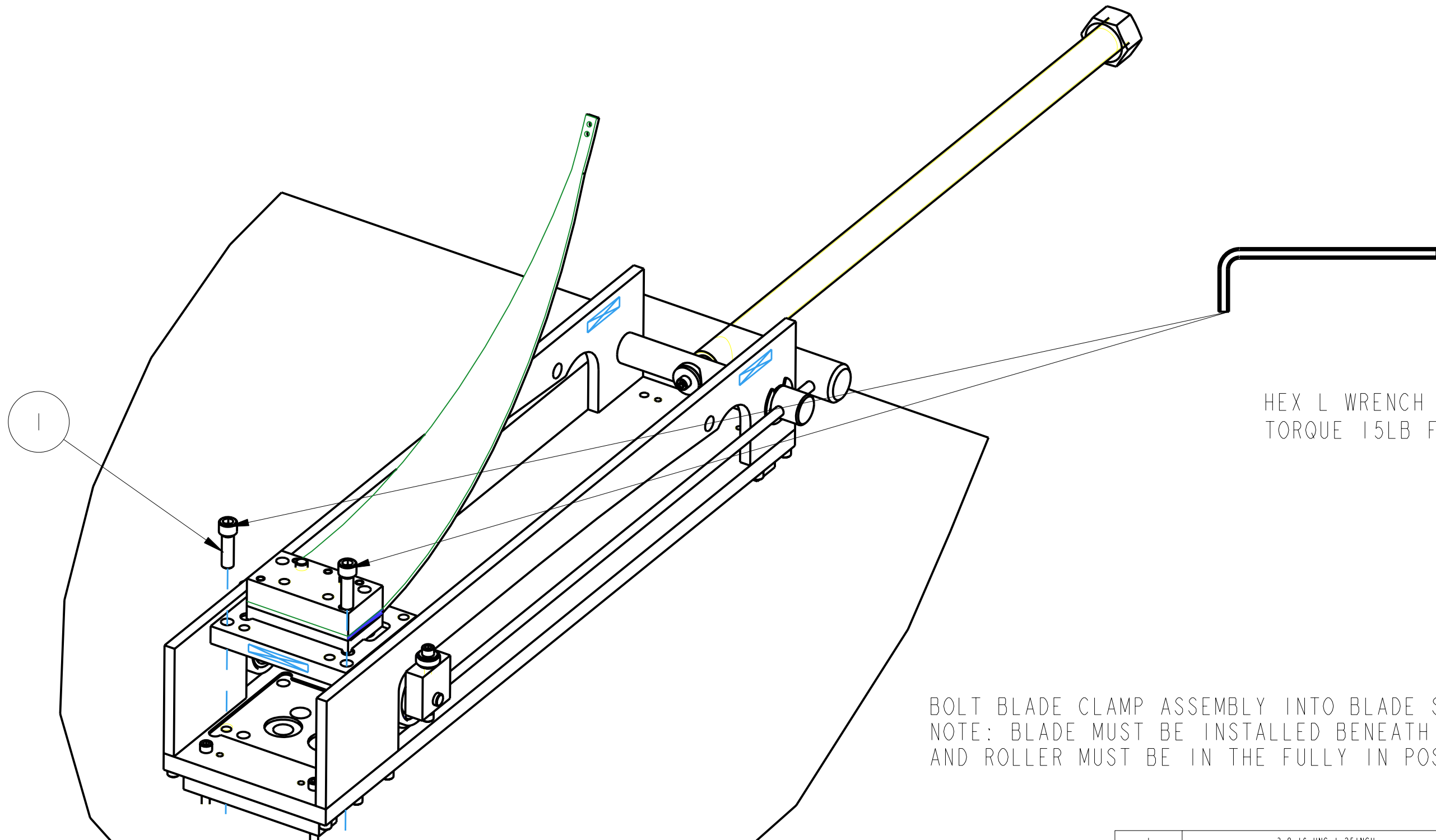

NOTES: (UNLESS OTHERWISE SPECIFIED)		CALIFORNIA INSTITUTE OF TECHNOLOGY MASSACHUSETTS INSTITUTE OF TECHNOLOGY IGR, GLASGOW UNIVERSITY GEO 600 GROUP RUTHERFORD APPLETON LABORATORIES	
1.		SYSTEM aLIGO SUB-SYSTEM SUS NEXT ASSY QUAD PART NAME TS ASSEMBLY PROCEDURE QUAD TS AND TOOLING	
PROCESS PLAN TO BE USED FOR ASSEMBLY ONLY NOT TO BE USED FOR MANUFACTURE		DRAWN J O'DELL 02/11/09 CHECKED J'OD 18/MAR/10 APPROVED JOD 18/MAR/10	
SCALE 1:2		DRG. NO. D060370_ASM_PROCEDURE	REV. A.
PROJECTION:		SHEET 5 OF 1	

REV.	DATE	DCN #	DRAWING TREE #



HEX L WRENCH SIZE: 5/16
TORQUE 15LB FT

BOLT BLADE CLAMP ASSEMBLY INTO BLADE STREIGHTENING TOOLING
NOTE: BLADE MUST BE INSTALLED BENEATH ROLLER,
AND ROLLER MUST BE IN THE FULLY IN POSITION

1	3-8.16 UNC 1-25 INCH	3/8 16 UNC X 1.25" CAP HEAD	2
No.	PART NUMBER	PART DESCRIPTION	NO. REOD
NOTES: (UNLESS OTHERWISE SPECIFIED)			
1.	PROCESS PLAN TO BE USED FOR ASSEMBLY ONLY NOT TO BE USED FOR MANUFACTURE		 CALIFORNIA INSTITUTE OF TECHNOLOGY MASSACHUSETTS INSTITUTE OF TECHNOLOGY IGR, GLASGOW UNIVERSITY GEO 600 GROUP RUTHERFORD APPLETON LABORATORIES
		SYSTEM	aLIGO
		SUB-SYSTEM	SUS
		NEXT ASSY	QUAD
		PART NAME	TS ASSEMBLY PROCEDURE QUAD TS AND TOOLING
	NAME	DATE	SIZE
	DRAWN J O'DELL	02/11/09	B
	CHECKED J'OD	18/MAR/10	DRG. NO. D060370_ASM_PROCEDURE
	APPROVED JOD	18/MAR/10	REV. A.
SCALE 3:10 PROJECTION:  SHEET 6 OF 1			

D
C
B
A

D
C
B
A



THREADED SHAFT

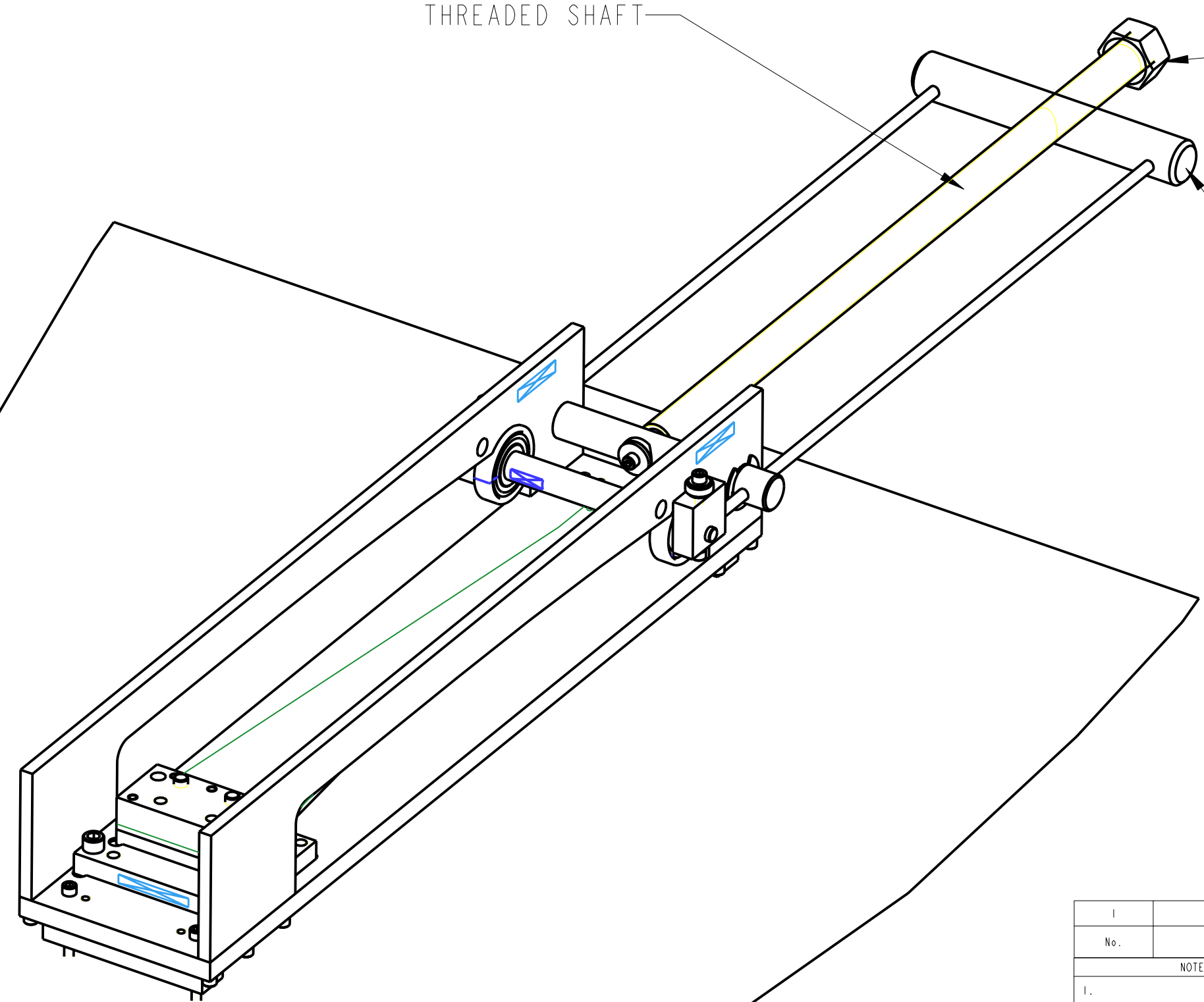

BLADE STRAIGHTENER HANDLE



DRAW THE BLADE FLAT
THIS IS DONE BY TURNING THE
THREADED SHAFT, SUCH THAT
THE BLADE STRAIGHTENER
HANDLE IS WOUND OUT

I	D1200116	TOP STAGE BLADES	I
No.	PART NUMBER	PART DESCRIPTION	NO. REOD
NOTES: (UNLESS OTHERWISE SPECIFIED)		 CALIFORNIA INSTITUTE OF TECHNOLOGY MASSACHUSETTS INSTITUTE OF TECHNOLOGY IGR, GLASGOW UNIVERSITY GEO 600 GROUP RUTHERFORD APPLETON LABORATORIES	
1.		PROCESS PLAN TO BE USED FOR ASSEMBLY ONLY NOT TO BE USED FOR MANUFACTURE	
		SYSTEM aLIGO	
		SUB-SYSTEM SUS	
		NEXT ASSY QUAD	
		PART NAME TS ASSEMBLY PROCEDURE QUAD TS AND TOOLING	
	NAME	DATE	SIZE
DRAWN	J O'DELL	02/11/09	B
CHECKED	J'OD	18/MAR/10	
APPROVED	JOD	18/MAR/10	
		DRG. NO. D060370_ASM_PROCEDURE	
		SCALE 3:10 PROJECTION:  SHEET 7 OF 1	

8 7 6 5 4 3 2 1

REV.	DATE	DCN #	DRAWING TREE #

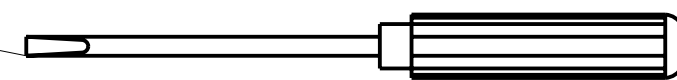
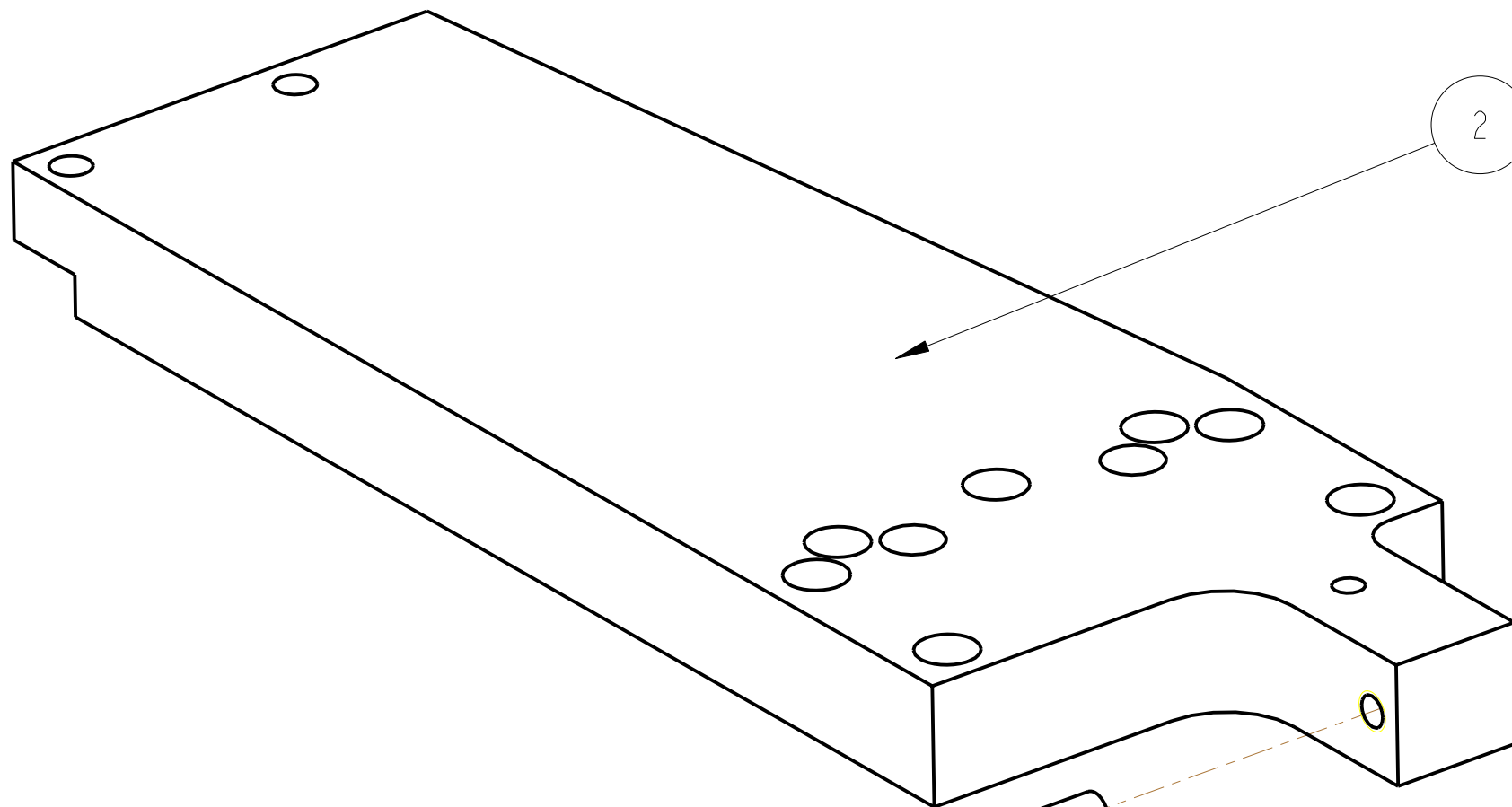

1/4 UNC
THREAD INSERTION TOOL

HELICOIL ROTATIONAL ADJUSTER



1	1-4_20X1-5D_UNC_THREAD_INSERT	1/4-20 x 1.5D UNC THREAD INSERT	1
2	D060330	ROTATIONAL ADJUSTER	1
No.	PART NUMBER	PART DESCRIPTION	NO. REOD

NOTES: (UNLESS OTHERWISE SPECIFIED)

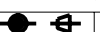
1.

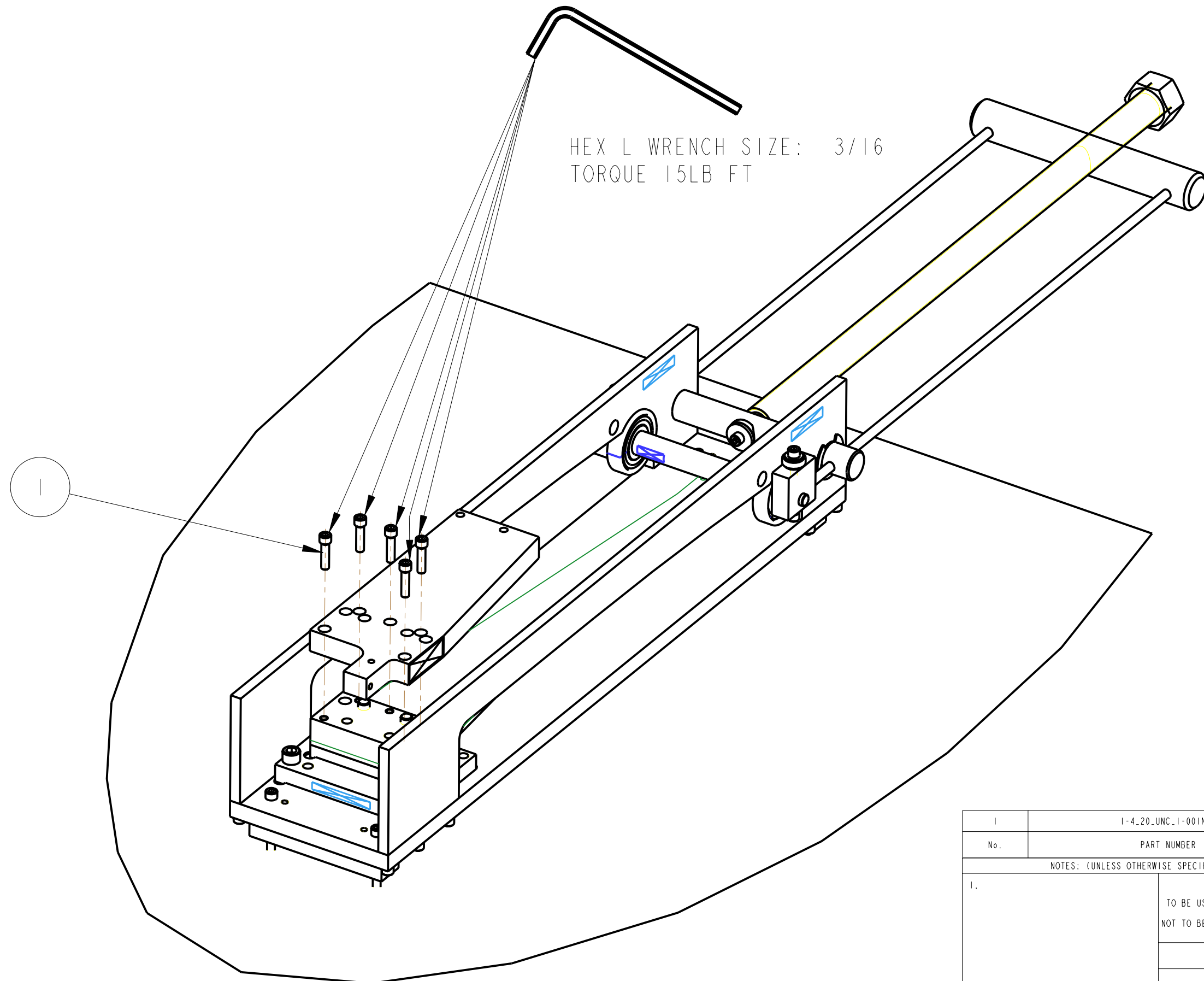
PROCESS PLAN TO BE USED FOR ASSEMBLY ONLY NOT TO BE USED FOR MANUFACTURE		 CALIFORNIA INSTITUTE OF TECHNOLOGY MASSACHUSETTS INSTITUTE OF TECHNOLOGY IGR, GLASGOW UNIVERSITY GEO 600 GROUP RUTHERFORD APPLETON LABORATORIES
SYSTEM aLIGO		
SUB-SYSTEM SUS		
NEXT ASSY QUAD		
PART NAME TS ASSEMBLY PROCEDURE QUAD TS AND TOOLING		SIZE B DRG. NO. D060370_ASM_PROCEDURE REV. A. SCALE 1:1 PROJECTION:  SHEET 8 OF 1
DRAWN	J O'DELL 18/03/10	
CHECKED	J'OD 18/MAR/10	
APPROVED	JOD 18/MAR/10	



1	1-4_20_UNC_1-001NCH	1/4" 20 UNC X 1" CAP HEAD	5
No.	PART NUMBER	PART DESCRIPTION	NO. REOD
NOTES: (UNLESS OTHERWISE SPECIFIED)			
1.	PROCESS PLAN TO BE USED FOR ASSEMBLY ONLY NOT TO BE USED FOR MANUFACTURE		 CALIFORNIA INSTITUTE OF TECHNOLOGY MASSACHUSETTS INSTITUTE OF TECHNOLOGY 1GR, GLASGOW UNIVERSITY GEO 600 GROUP RUTHERFORD APPLETON LABORATORIES
		SYSTEM	aLIGO
		SUB-SYSTEM	SUS
		NEXT ASSY	QUAD
		PART NAME	TS ASSEMBLY PROCEDURE QUAD TS AND TOOLING
	NAME	DATE	SIZE
	DRAWN J O'DELL	02/11/09	B
	CHECKED J'OD	18/MAR/10	DRG. NO. D060370_ASM_PROCEDURE
	APPROVED JOD	18/MAR/10	REV A.
SCALE 3:10 PROJECTION:  SHEET 9 OF 11			

REV.	DATE	DCN #	DRAWING TREE #

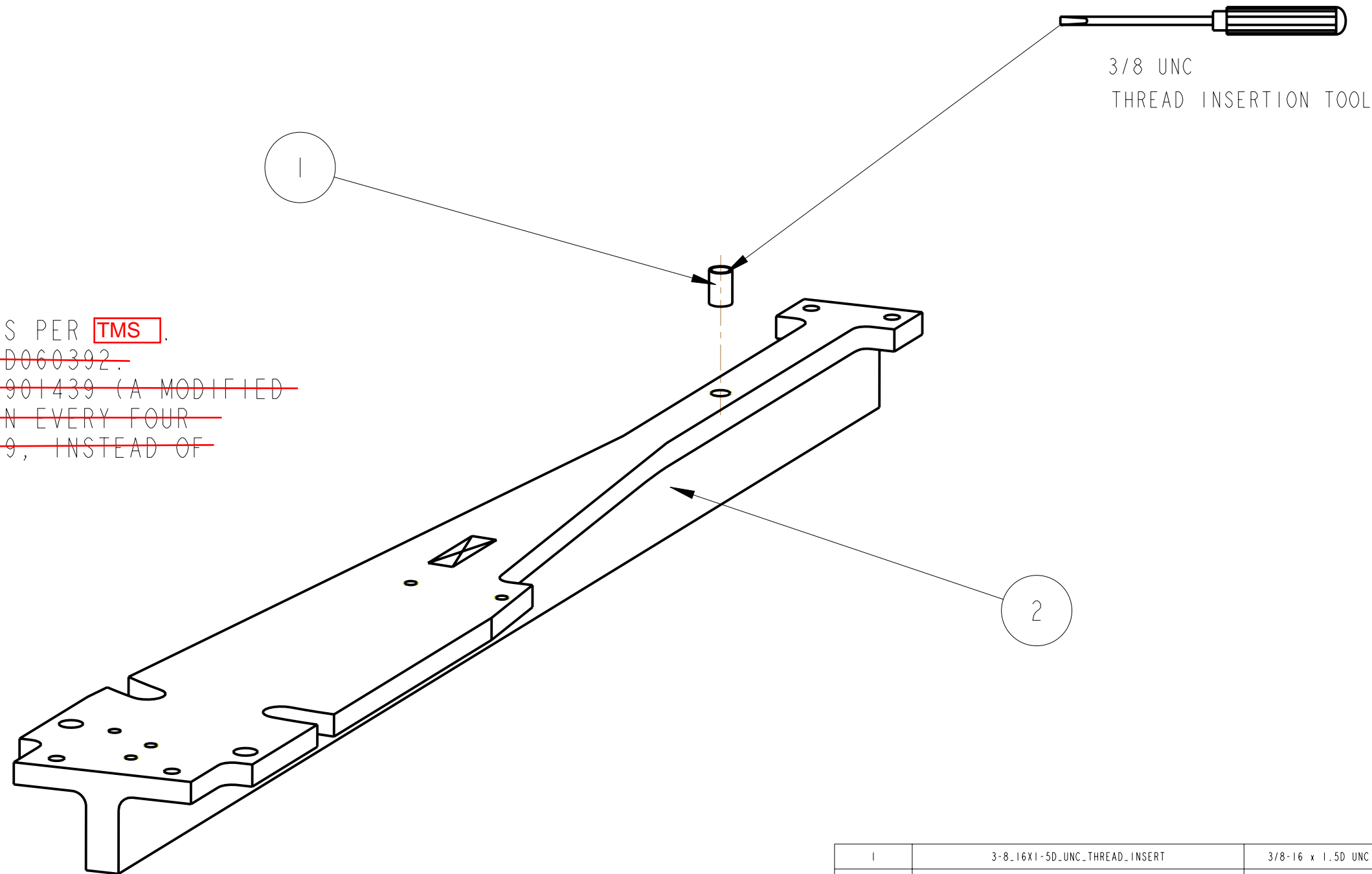

NOTE:

THERE ARE **TWO** TOP STAGE UNITS PER **TMS**.
~~THREE OF THESE USE PART 2 AS D060392.~~
~~IN ONE INSTANCE, PART 2 IS D0901439 (A MODIFIED~~
~~BACKBONE VERSION) MAKE ONE IN EVERY FOUR~~
~~TOP STAGE UNITS USING D0901439, INSTEAD OF~~
~~D060329, SHOWN IN THIS VIEW.~~

HELICOIL ROTATIONAL ADJUSTER

1	3-8_16X1-5D_UNC_THREAD_INSERT	3/8-16 x 1.5D UNC THREAD INSERT	1
2	D060329	TOP STAGE STIFF BACK	1
No.	PART NUMBER	PART DESCRIPTION	NO. REOD
NOTES: (UNLESS OTHERWISE SPECIFIED)			
1.		CALIFORNIA INSTITUTE OF TECHNOLOGY MASSACHUSETTS INSTITUTE OF TECHNOLOGY IGR, GLASGOW UNIVERSITY GEO 600 GROUP RUTHERFORD APPLETON LABORATORIES	
PROCESS PLAN TO BE USED FOR ASSEMBLY ONLY NOT TO BE USED FOR MANUFACTURE		SYSTEM aLIGO	
		SUB-SYSTEM SUS	
		NEXT ASSY QUAD	
		PART NAME TS ASSEMBLY PROCEDURE QUAD TS AND TOOLING	
	NAME	DATE	SIZE
DRAWN	J O'DELL	18/03/10	B
CHECKED	J'OD	18/MAR/10	
APPROVED	JOD	18/MAR/10	
		DRG. NO. D060370_ASM_PROCEDURE	REV A.
SCALE 1:2		PROJECTION:	SHEET 10 OF 9

REV.	DATE	DCN #	DRAWING TREE #

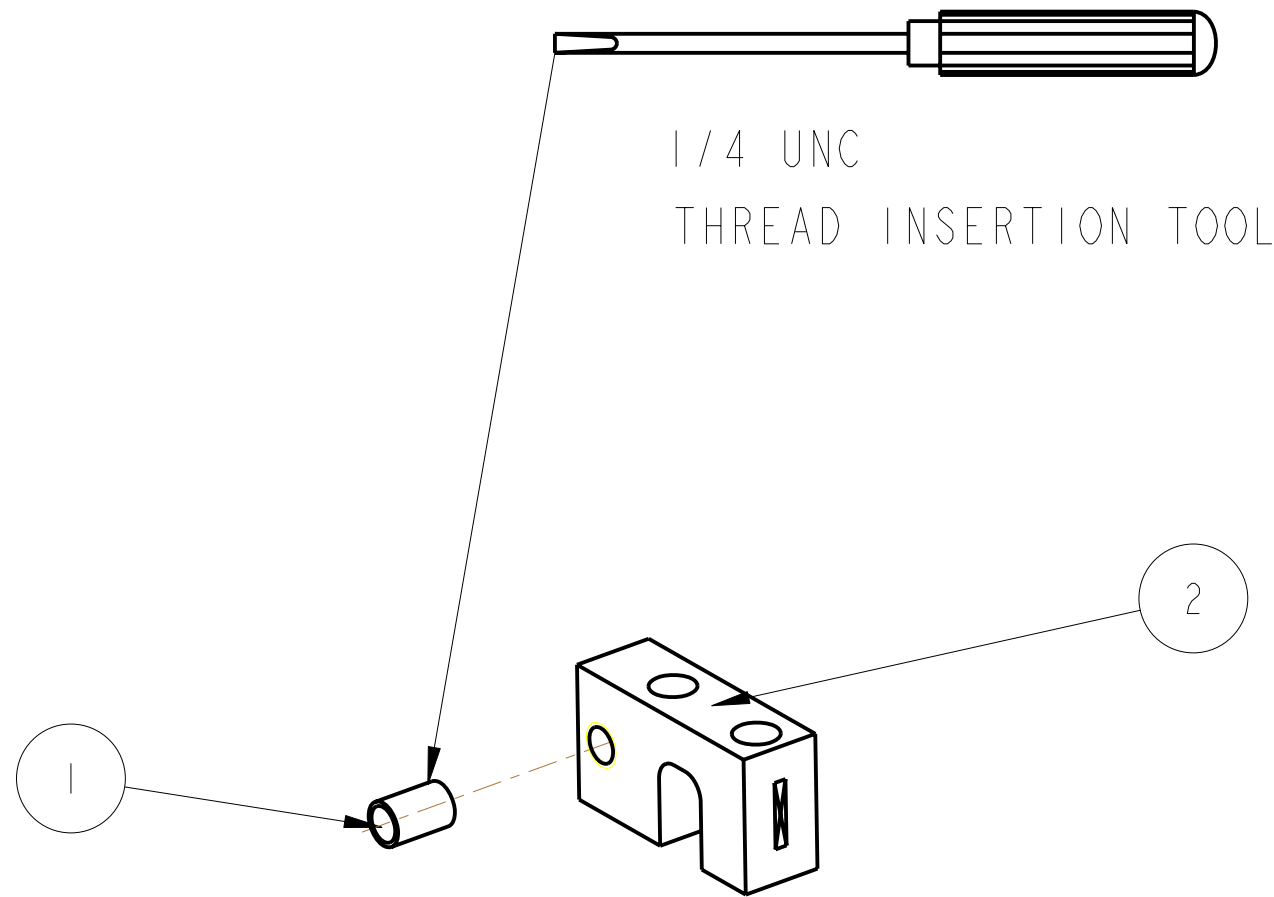

HELICOIL ROTATIONAL ADJUSTER BRACKET

No.	PART NUMBER	PART DESCRIPTION	NO. REOD
1	1-4_20X1-5D_UNC_THREAD_INSERT	1/4-20 x 1.5D UNC THREAD INSERT	1
2	D060325	ROTATIONAL ADJUSTER	1

NOTES: (UNLESS OTHERWISE SPECIFIED)		CALIFORNIA INSTITUTE OF TECHNOLOGY MASSACHUSETTS INSTITUTE OF TECHNOLOGY 1GR, GLASGOW UNIVERSITY GEO 600 GROUP RUTHERFORD APPLETON LABORATORIES
1.	PROCESS PLAN TO BE USED FOR ASSEMBLY ONLY NOT TO BE USED FOR MANUFACTURE	
		SYSTEM aLIGO
		SUB-SYSTEM SUS
		NEXT ASSY QUAD
		PART NAME TS ASSEMBLY PROCEDURE QUAD TS AND TOOLING
	NAME DATE	SIZE
DRAWN	J O'DELL 18/03/10	B DRG. NO. D060370_ASM_PROCEDURE REV A.
CHECKED	J'OD 18/MAR/10	
APPROVED	JOD 18/MAR/10	
SCALE 1:1		PROJECTION:

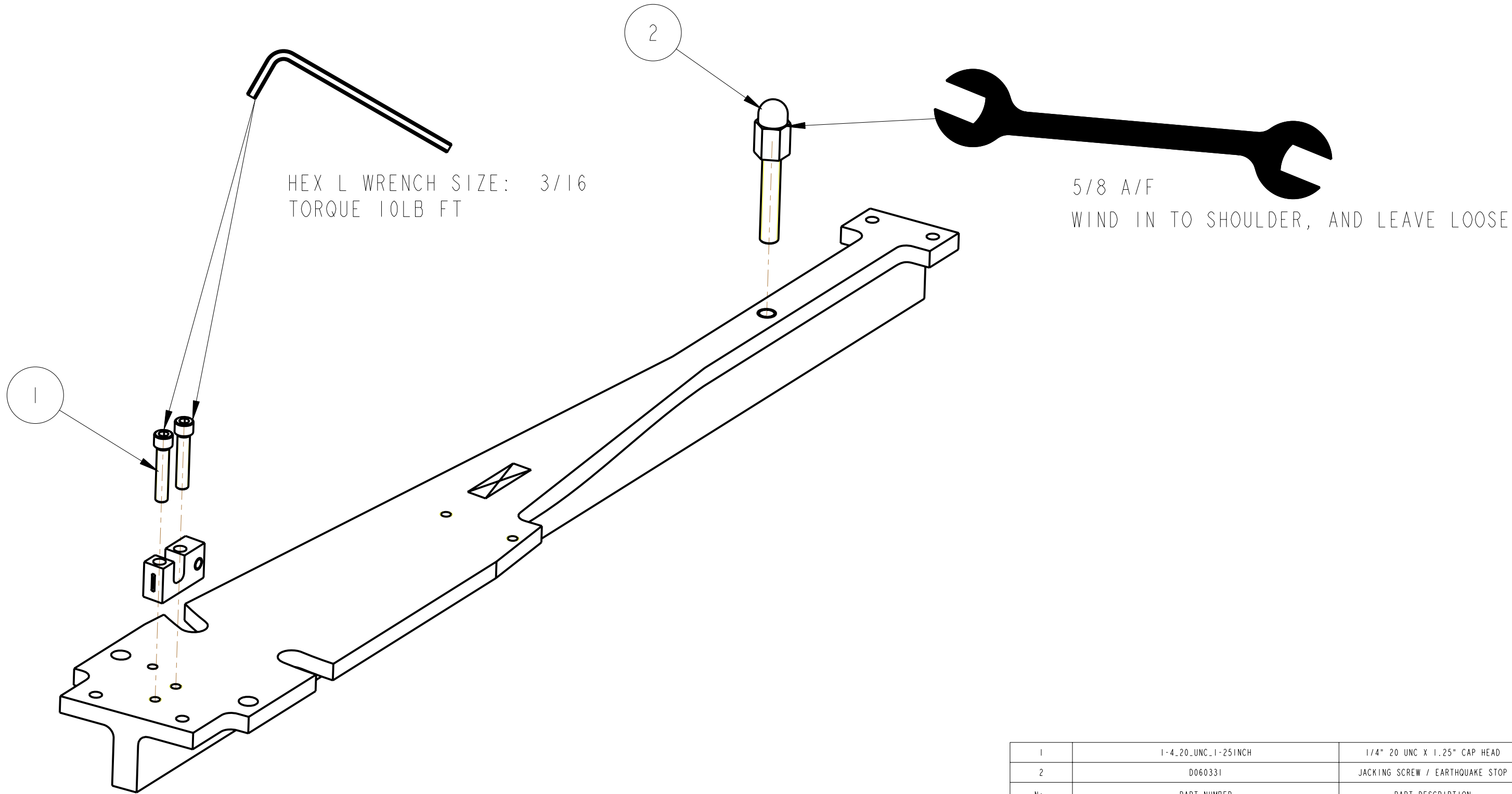

HEX L WRENCH SIZE: 3/16
TORQUE 10LB FT

5/8 A/F
WIND IN TO SHOULDER, AND LEAVE LOOSE

ADD BLADE TIP STOP AND ROTATIONAL
ADJUSTER BRACKET TO TS STIFF BACK

1	1-4_20_UNC_1-25INCH	1/4" 20 UNC X 1.25" CAP HEAD	2
2	D060331	JACKING SCREW / EARTHQUAKE STOP	1
No.	PART NUMBER	PART DESCRIPTION	NO. REOD
NOTES: (UNLESS OTHERWISE SPECIFIED)			
1.		CALIFORNIA INSTITUTE OF TECHNOLOGY MASSACHUSETTS INSTITUTE OF TECHNOLOGY IGR, GLASGOW UNIVERSITY GEO 600 GROUP RUTHERFORD APPLETON LABORATORIES	
PROCESS PLAN TO BE USED FOR ASSEMBLY ONLY NOT TO BE USED FOR MANUFACTURE		SYSTEM aLIGO SUB-SYSTEM SUS NEXT ASSY QUAD PART NAME TS ASSEMBLY PROCEDURE QUAD TS AND TOOLING	
	NAME	DATE	SIZE
DRAWN	J O'DELL	02/11/09	B
CHECKED	J'OD	18/MAR/10	DRG. NO. D060370_ASM_PROCEDURE
APPROVED	JOD	18/MAR/10	REV A.
SCALE 1:2		PROJECTION:	SHEET 12 OF 9

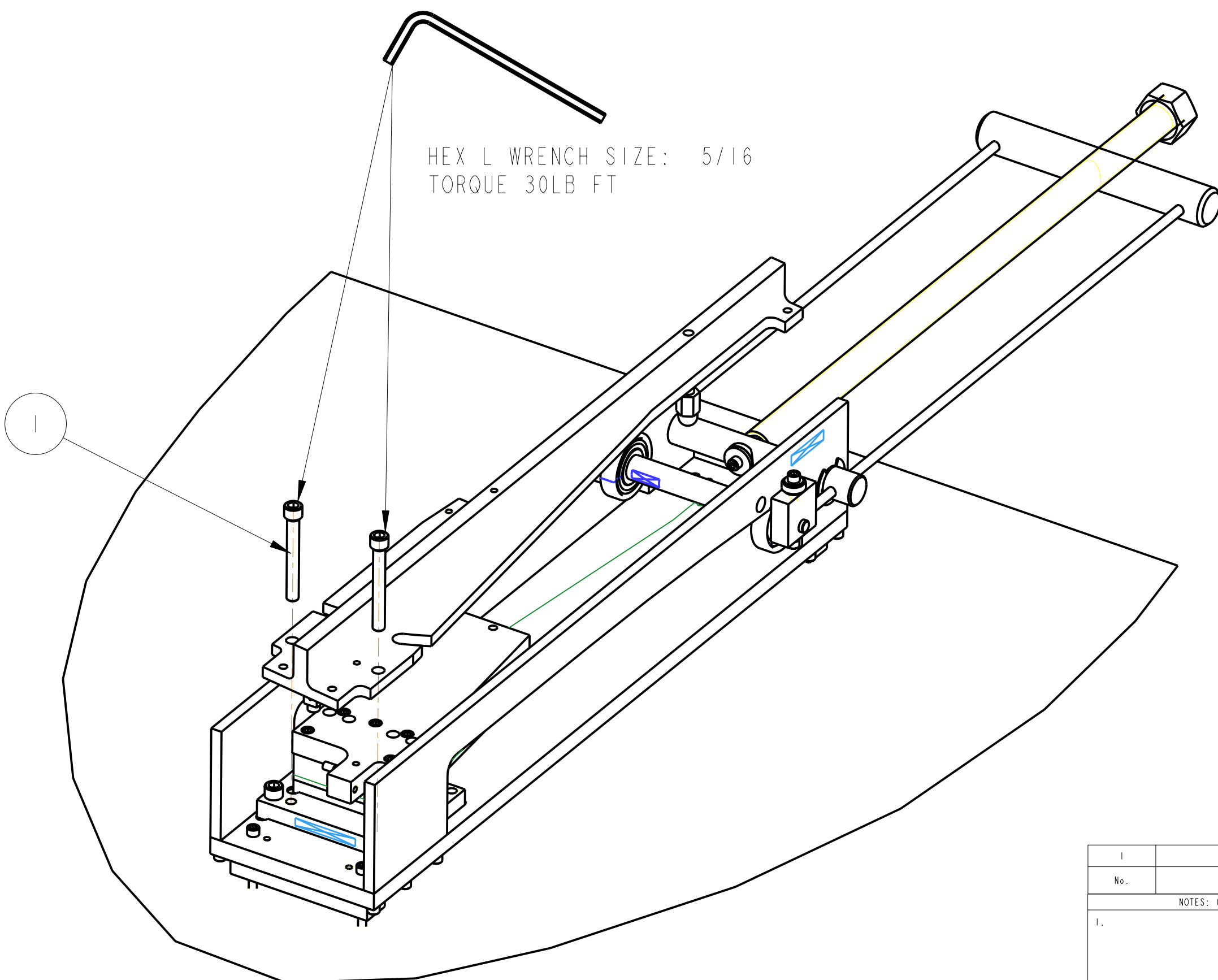

HEX L WRENCH SIZE: 5/16
TORQUE 30LB FT

ASSEMBLE BACKBONE TO THE REST OF THE BLADE CARTRIDGE

I	3-8.16 UNC 3-00 INCH	3/8-16 UNC X 3.0" CAP HEAD	2
No.	PART NUMBER	PART DESCRIPTION	NO. REOD
NOTES: (UNLESS OTHERWISE SPECIFIED)			
1.		CALIFORNIA INSTITUTE OF TECHNOLOGY MASSACHUSETTS INSTITUTE OF TECHNOLOGY IGR, GLASGOW UNIVERSITY GEO 600 GROUP RUTHERFORD APPLETON LABORATORIES	
PROCESS PLAN TO BE USED FOR ASSEMBLY ONLY NOT TO BE USED FOR MANUFACTURE		SYSTEM aLIGO	
		SUB-SYSTEM SUS	
		NEXT ASSY QUAD	
		PART NAME TS ASSEMBLY PROCEDURE QUAD TS AND TOOLING	
	NAME	DATE	
DRAWN	J O'DELL	02/11/09	
CHECKED	J'OD	18/MAR/10	
APPROVED	JOD	18/MAR/10	
SIZE	DRG. NO. D060370_ASM_PROCEDURE		REV. A.
SCALE 3:10 PROJECTION:			SHEET 13 OF 19

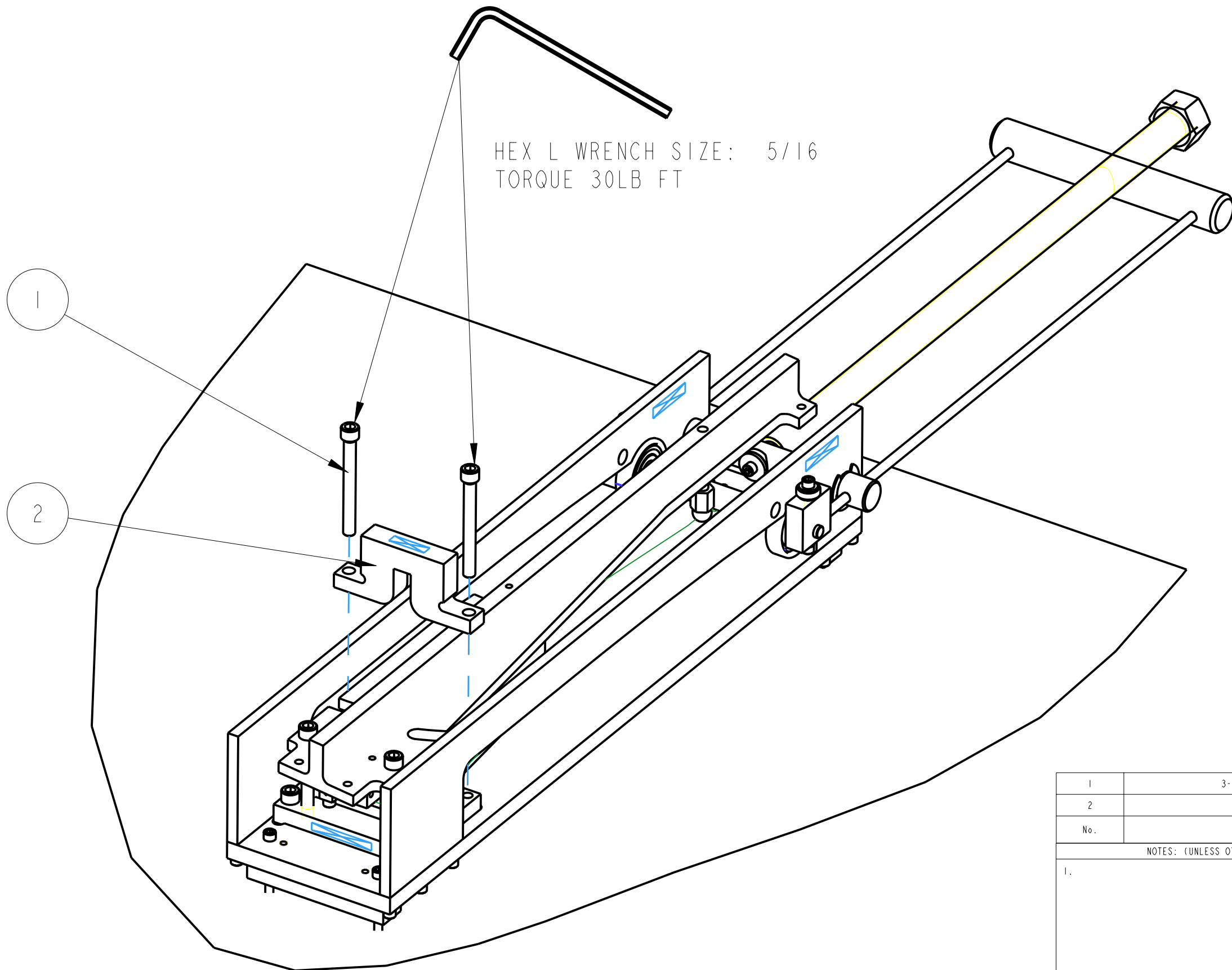

HEX L WRENCH SIZE: 5/16
TORQUE 30LB FT

ADD TEMPORARY CLAMP

1	3-8.16 UNC 3-5 INCH	3/8-16 UNC X 3.5" CAP HEAD	2
2	D060368	BLADE CLAMP TOP BLOCK	1
No.	PART NUMBER	PART DESCRIPTION	NO. REOD
NOTES: (UNLESS OTHERWISE SPECIFIED)		CALIFORNIA INSTITUTE OF TECHNOLOGY MASSACHUSETTS INSTITUTE OF TECHNOLOGY 1GR, GLASGOW UNIVERSITY GEO 600 GROUP RUTHERFORD APPLETON LABORATORIES	
1.		PROCESS PLAN TO BE USED FOR ASSEMBLY ONLY NOT TO BE USED FOR MANUFACTURE	
		SYSTEM aLIGO	
		SUB-SYSTEM SUS	
		NEXT ASSY QUAD	
		PART NAME TS ASSEMBLY PROCEDURE QUAD TS AND TOOLING	
	NAME	DATE	SIZE
DRAWN	J O'DELL	18/03/10	B
CHECKED	J'OD	18/MAR/10	
APPROVED	JOD	18/MAR/10	
		DRG. NO. D060370_ASM_PROCEDURE	
		SCALE 3:10 PROJECTION:	
		SHEET 14 OF 19	

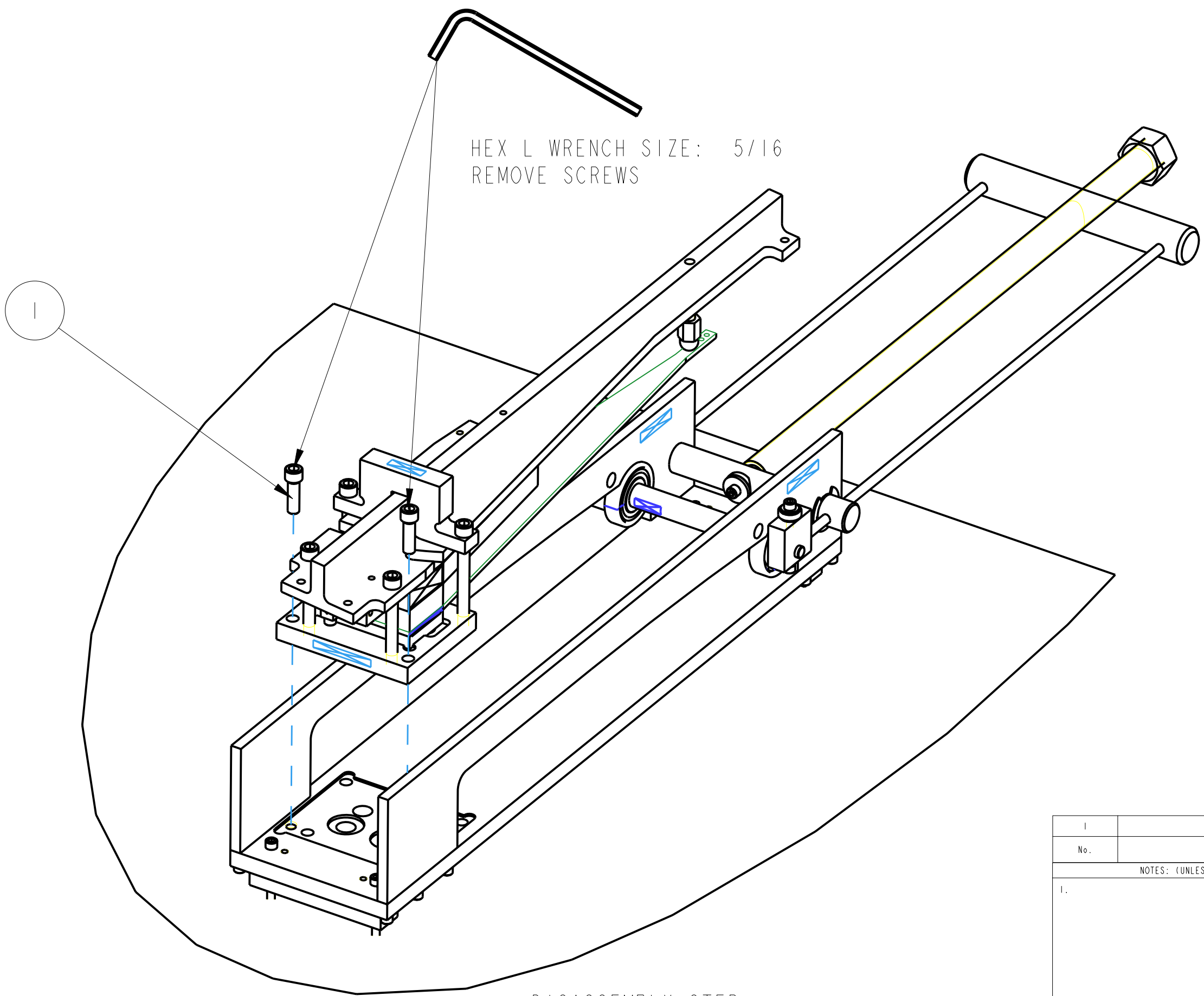

HEX L WRENCH SIZE: 5/16
REMOVE SCREWS

DISASSEMBLY STEP
REMOVE BLADE CARTRIDGE FROM TOOLING

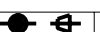
1	3-8.16 UNC 1-25 INCH	3/8 16 UNC X 1.25" CAP HEAD	2
No.	PART NUMBER	PART DESCRIPTION	NO. REOD
NOTES: (UNLESS OTHERWISE SPECIFIED)			
1.		PROCESS PLAN TO BE USED FOR ASSEMBLY ONLY NOT TO BE USED FOR MANUFACTURE	 CALIFORNIA INSTITUTE OF TECHNOLOGY MASSACHUSETTS INSTITUTE OF TECHNOLOGY IGR, GLASGOW UNIVERSITY GEO 600 GROUP RUTHERFORD APPLETON LABORATORIES
		SYSTEM	aLIGO
		SUB-SYSTEM	SUS
		NEXT ASSY	QUAD
		PART NAME	TS ASSEMBLY PROCEDURE QUAD TS AND TOOLING
	NAME	DATE	SIZE
DRAWN	J O'DELL	02/11/09	B
CHECKED	J'OD	18/MAR/10	DRG. NO.
APPROVED	JOD	18/MAR/10	D060370_ASM_PROCEDURE
SCALE 3:10 PROJECTION: 			REV
			A.
			SHEET 15 OF 19

REV.	DATE	DCN #	DRAWING TREE #

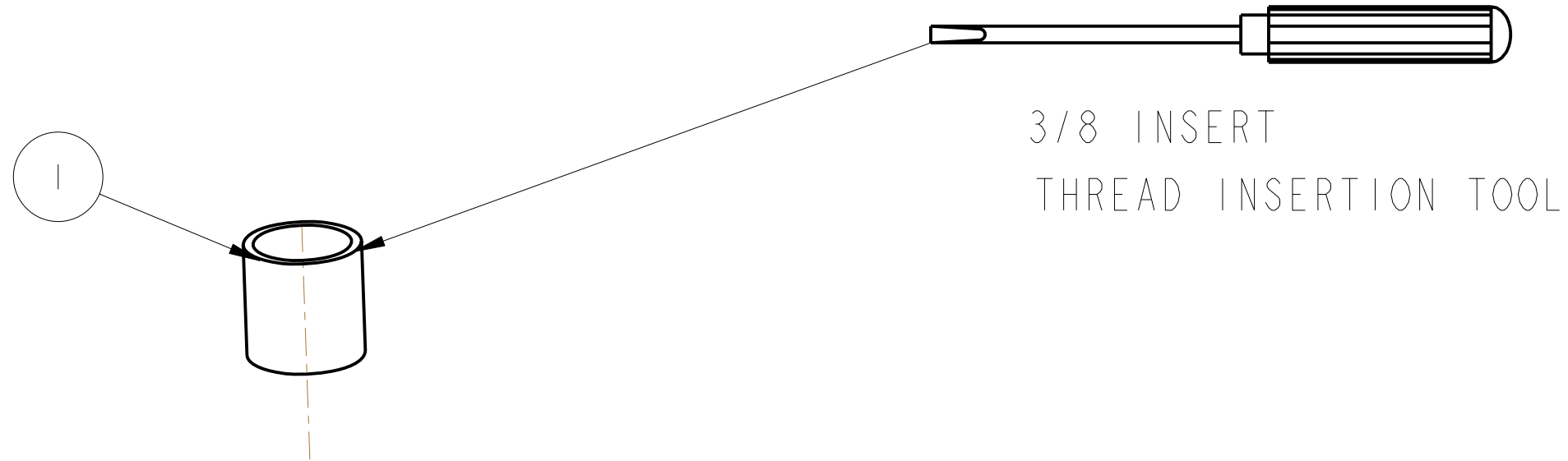

3/8 INSERT
THREAD INSERTION TOOL

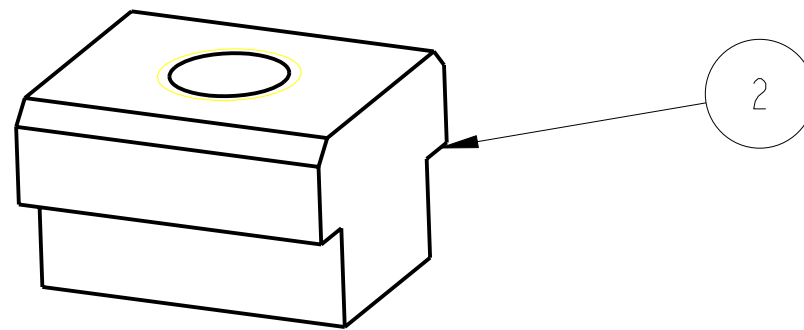

SCALE 2:1

HELICOIL TEE-NUTS
X 2

No.	PART NUMBER	PART DESCRIPTION	NO. REOD
1	3-8-.16XID.UNC.THREAD.INSERT	3/8-16 x ID UNC THREAD INSERT	2
2	D060328	3/8-16 UNC T NUT	2

NOTES: (UNLESS OTHERWISE SPECIFIED)

1.

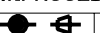
PROCESS PLAN TO BE USED FOR ASSEMBLY ONLY NOT TO BE USED FOR MANUFACTURE		 CALIFORNIA INSTITUTE OF TECHNOLOGY MASSACHUSETTS INSTITUTE OF TECHNOLOGY 1GR, GLASGOW UNIVERSITY GEO 600 GROUP RUTHERFORD APPLETON LABORATORIES
SYSTEM aLIGO		
SUB-SYSTEM SUS		
NEXT ASSY QUAD		
PART NAME TS ASSEMBLY PROCEDURE QUAD TS AND TOOLING		SIZE B DRG. NO. D060370_ASM_PROCEDURE REV A. SCALE 1:1 PROJECTION:  SHEET 16 OF 19
DRAWN	J O'DELL 18/03/10	
CHECKED	J'OD 18/MAR/10	
APPROVED	JOD 18/MAR/10	

REV.	DATE	DCN #	DRAWING TREE #

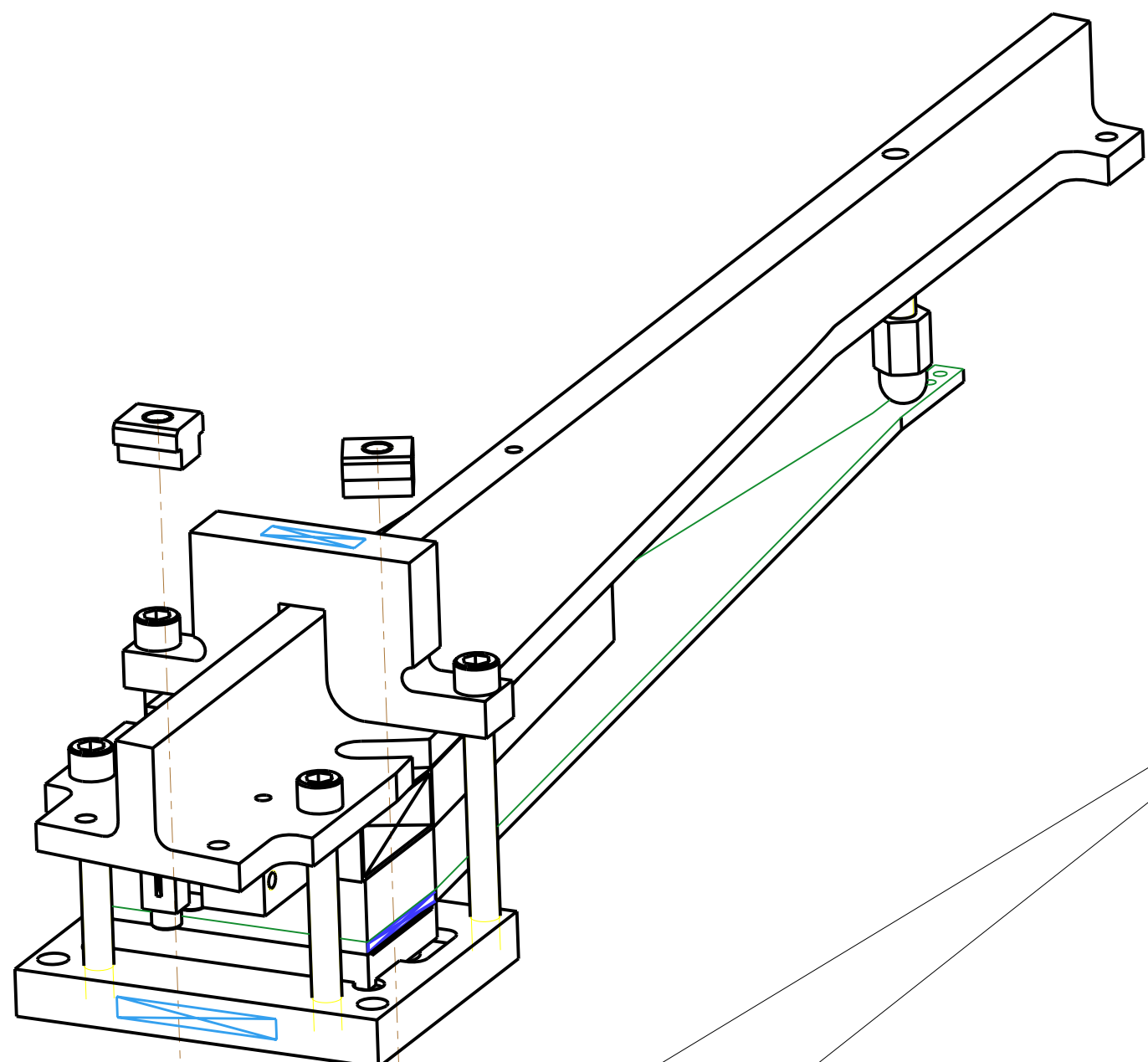

BOLT TS ASSEMBLY TOGETHER WITH
CAP SCREWS AND TEE-NUTS

HEX L WRENCH SIZE: 5/16
TORQUE 40LB FT

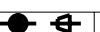
1	3-8_16 UNC_3-00 INCH	3/8-16 UNC X 3.0" CAP HEAD	2
No.	PART NUMBER	PART DESCRIPTION	NO. REOD
NOTES: (UNLESS OTHERWISE SPECIFIED)		 CALIFORNIA INSTITUTE OF TECHNOLOGY MASSACHUSETTS INSTITUTE OF TECHNOLOGY 1GR, GLASGOW UNIVERSITY GEO 600 GROUP RUTHERFORD APPLETON LABORATORIES	
1.	PROCESS PLAN TO BE USED FOR ASSEMBLY ONLY NOT TO BE USED FOR MANUFACTURE	SYSTEM	aLIGO
		SUB-SYSTEM	SUS
		NEXT ASSY	QUAD
		PART NAME	TS ASSEMBLY PROCEDURE QUAD TS AND TOOLING
	NAME	DATE	
	DRAWN	J O'DELL	02/11/09
	CHECKED	J'OD	18/MAR/10
	APPROVED	JOD	18/MAR/10
	SIZE	DRG. NO.	REV
	B	D060370_ASM_PROCEDURE	A.
	SCALE 1:2	PROJECTION: 	SHEET 17 OF 19

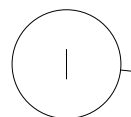

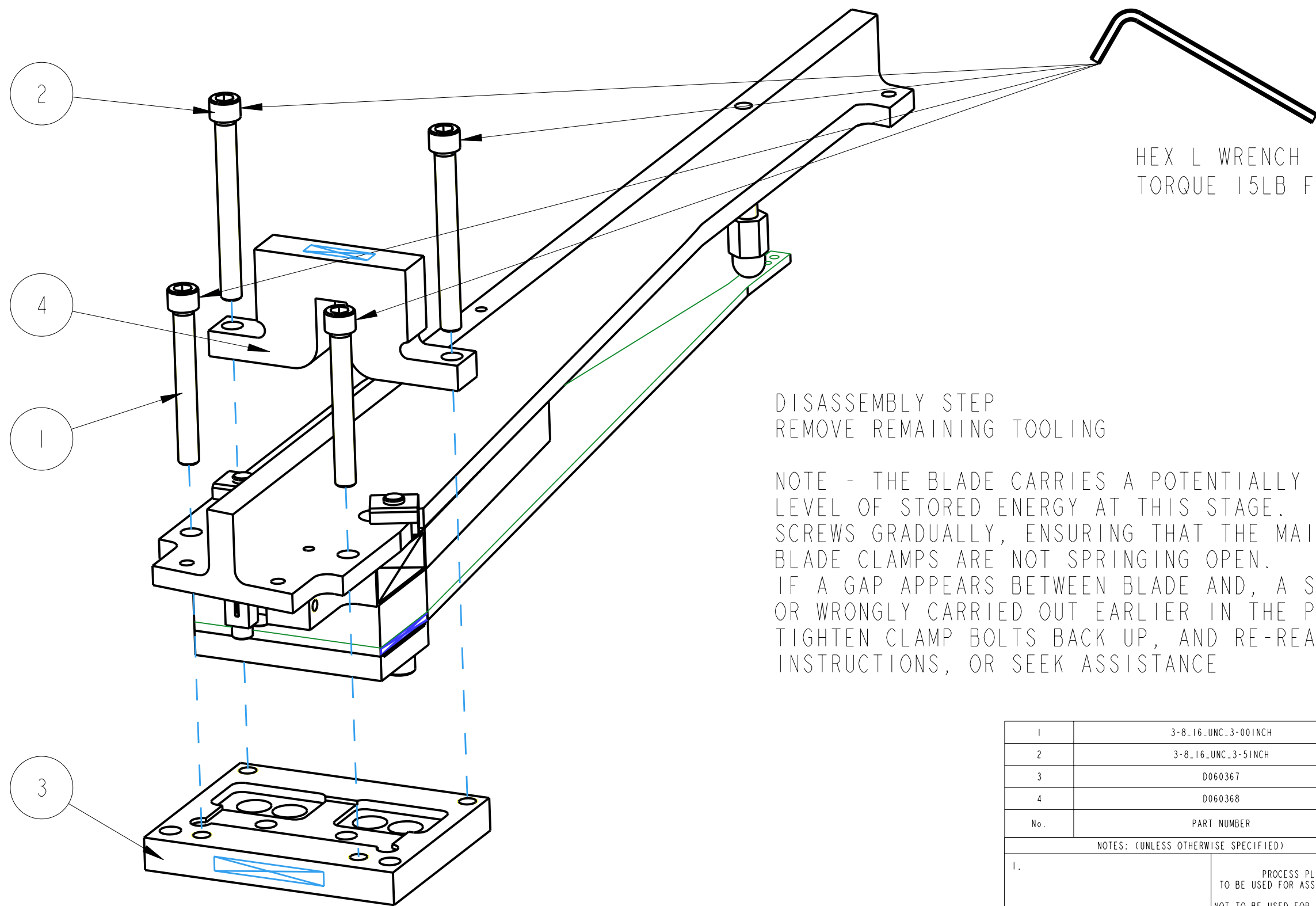

HEX L WRENCH SIZE: 5/16
TORQUE 15LB FT

DISASSEMBLY STEP
REMOVE REMAINING TOOLING

NOTE - THE BLADE CARRIES A POTENTIALLY DANGEROUS LEVEL OF STORED ENERGY AT THIS STAGE. RELEASE CLAMPING SCREWS GRADUALLY, ENSURING THAT THE MAIN (PERMINENT) BLADE CLAMPS ARE NOT SPRINGING OPEN. IF A GAP APPEARS BETWEEN BLADE AND, A STEP HAS BEEN MISSED OR WRONGLY CARRIED OUT EARLIER IN THE PROCEDURE. TIGHTEN CLAMP BOLTS BACK UP, AND RE-READ EARLIER INSTRUCTIONS, OR SEEK ASSISTANCE

1	3-8.16 UNC.3-001NCH	3/8-16 UNC X 3.0" CAP HEAD	2
2	3-8.16 UNC.3-51NCH	3/8-16 UNC X 3.5" CAP HEAD	2
3	D060367	BLADE CLAMP BASE BLOCK	1
4	D060368	BLADE CLAMP TOP BLOCK	1
No.	PART NUMBER	PART DESCRIPTION	NO. REOD

NOTES: (UNLESS OTHERWISE SPECIFIED)

1.

PROCESS PLAN TO BE USED FOR ASSEMBLY ONLY NOT TO BE USED FOR MANUFACTURE		CALIFORNIA INSTITUTE OF TECHNOLOGY MASSACHUSETTS INSTITUTE OF TECHNOLOGY 1GR, GLASGOW UNIVERSITY GEO 600 GROUP RUTHERFORD APPLETON LABORATORIES
		SYSTEM aLIGO
		SUB-SYSTEM SUS
		NEXT ASSY QUAD
		PART NAME TS ASSEMBLY PROCEDURE QUAD TS AND TOOLING
NAME	DATE	SIZE B DRG. NO. D060370_ASM_PROCEDURE REV A. SCALE 1:2 PROJECTION: SHEET 18 OF 19
DRAWN	J O'DELL 18/03/10	
CHECKED	J'OD 18/MAR/10	
APPROVED	JOD 18/MAR/10	

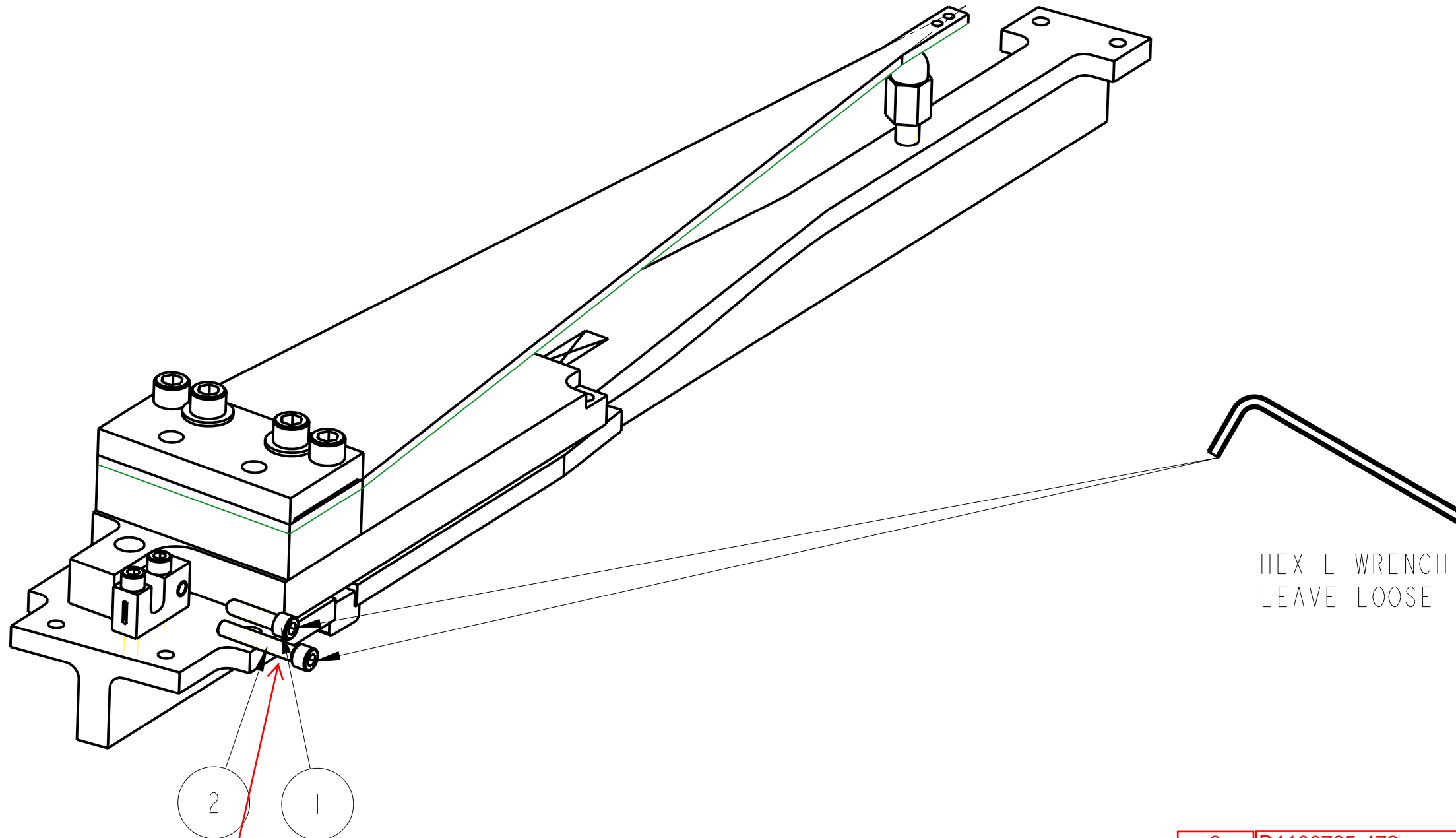

3

ADD ROTATIONAL ADJUSTER SCREWS

THIS STEP COMPLETES THE ASSEMBLY OF A QUAD TOP STAGE UNIT.
THERE ARE FOUR OF THESE UNITS REQUIRED FOR EACH QUAD

3	D1100785-472	NITRONIC 60 1/4 WASHER	1
1	1-4.20 UNC. 1-00INCH. ROUND.	1/4" 20 UNC X 2" CAP HEAD, SPHERICAL TIP	1
2	1-4.20 UNC. 1-5INCH	1/4-20 UNC X 1.5" CAP HEAD	1
No.	PART NUMBER	PART DESCRIPTION	NO. REQD

NOTES: (UNLESS OTHERWISE SPECIFIED)

1.

PROCESS PLAN TO BE USED FOR ASSEMBLY ONLY NOT TO BE USED FOR MANUFACTURE		CALIFORNIA INSTITUTE OF TECHNOLOGY MASSACHUSETTS INSTITUTE OF TECHNOLOGY IGR, GLASGOW UNIVERSITY GEO 600 GROUP RUTHERFORD APPLETON LABORATORIES
SYSTEM aLIGO		
SUB-SYSTEM SUS		
NEXT ASSY QUAD		
PART NAME TS ASSEMBLY PROCEDURE QUAD TS AND TOOLING		
NAME	DATE	
DRAWN J O'DELL	18/03/10	
CHECKED J'OD	18/MAR/10	
APPROVED JOD	18/MAR/10	
SIZE B	DRG. NO. D060370_ASM_PROCEDURE	REV A.
SCALE 1:2	PROJECTION:	SHEET 19 OF 19