

NOTES CONTINUED:

⑤ SCRIBE, ENGRAVE, OR MECHANICALLY STAMP (NO INKS OR DYES) DRAWING PART NUMBER AND REVISION ON NOTED SURFACE FOLLOWED ON THE NEXT LINE BY A THREE DIGIT SERIAL NUMBER. SERIAL NUMBERS START AT 001 FOR THE FIRST ARTICLE AND PROCEED CONSECUTIVELY. USE .07" HIGH CHARACTERS. EXAMPLE: DXXXXXX-VY, S/N 001. A VIBRATORY TOOL MAY BE USED.

⑥ MACHINE ALL SURFACES.

REV.	DATE	DCN #	DRAWING TREE #

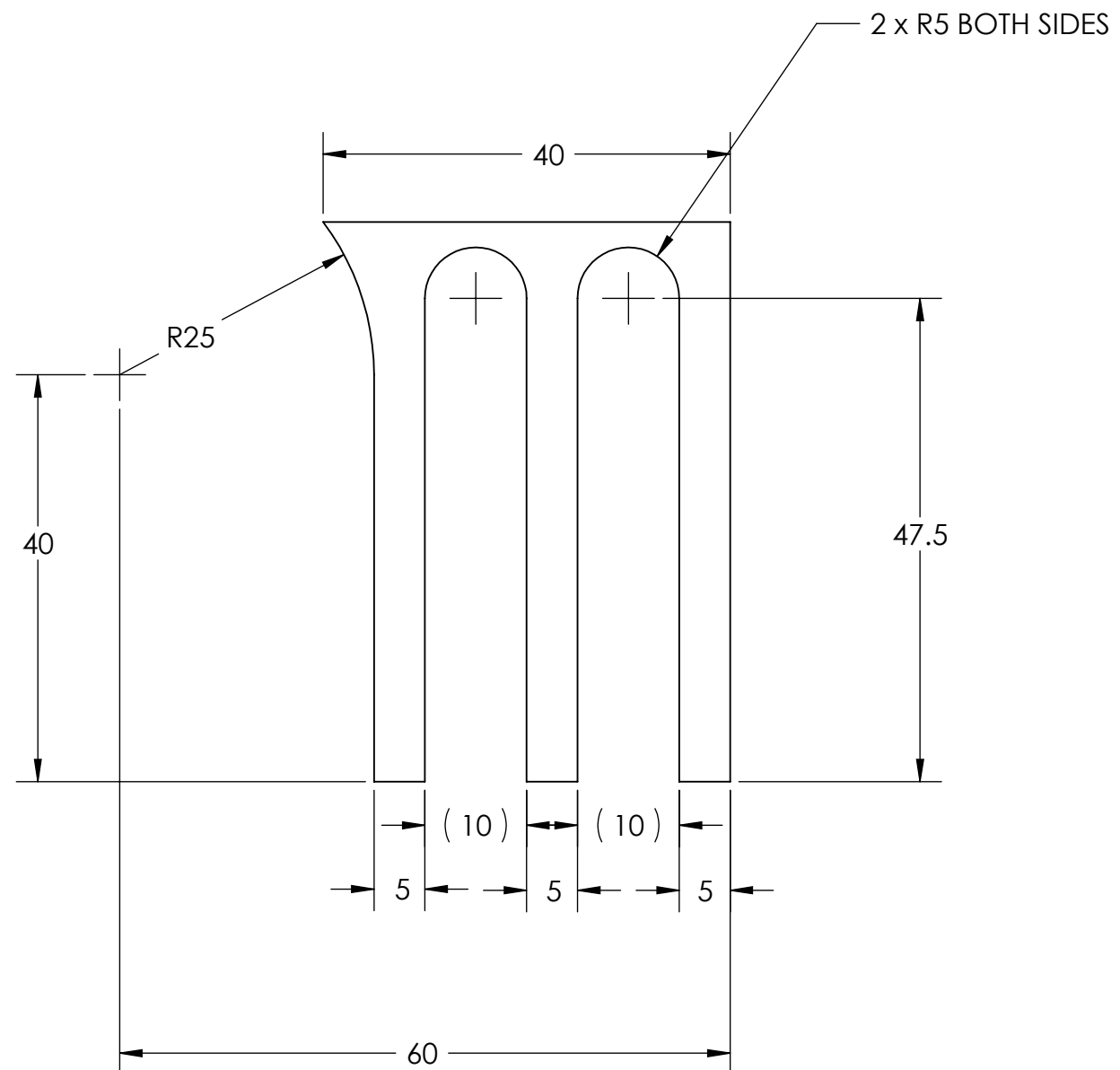
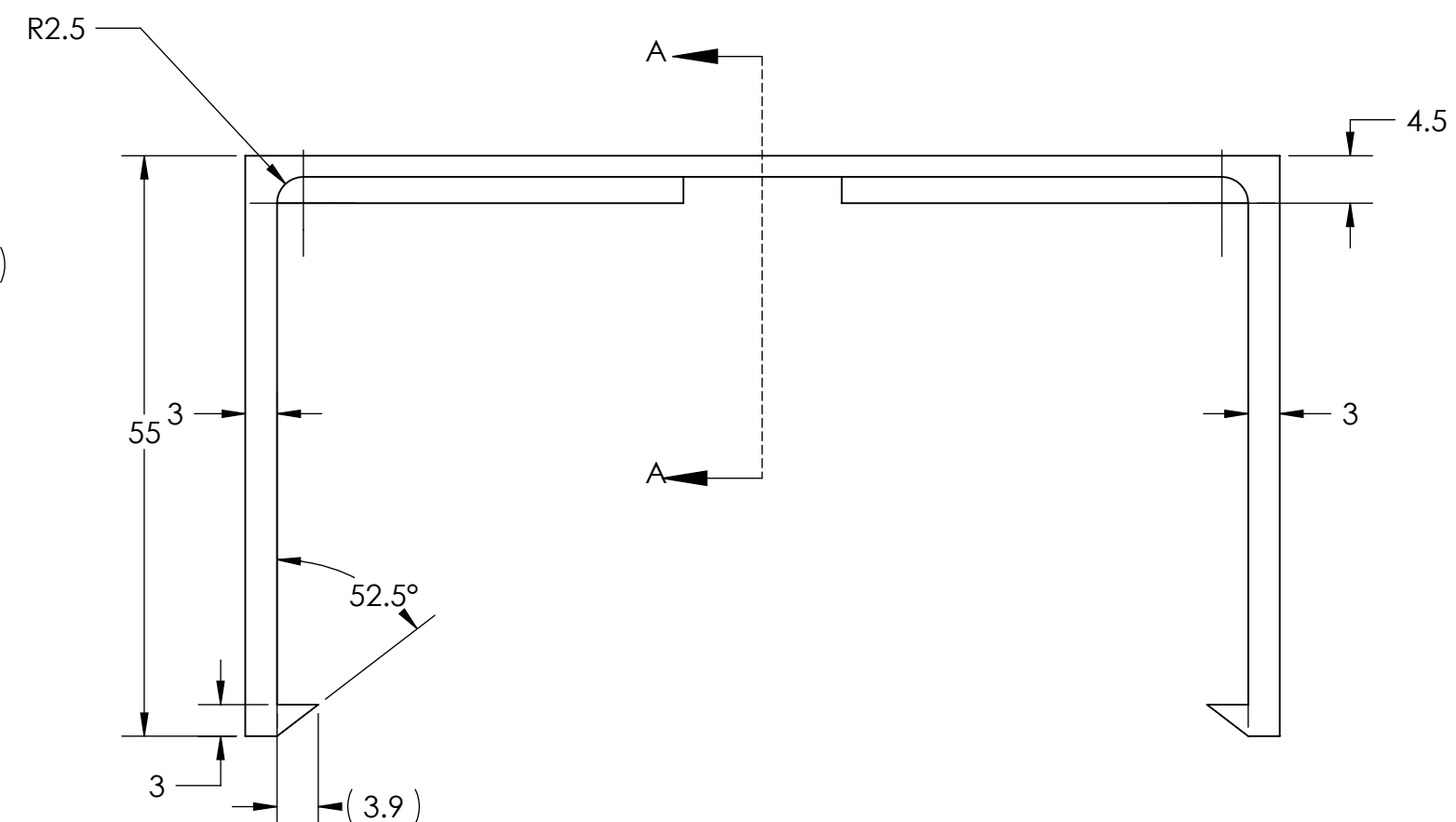
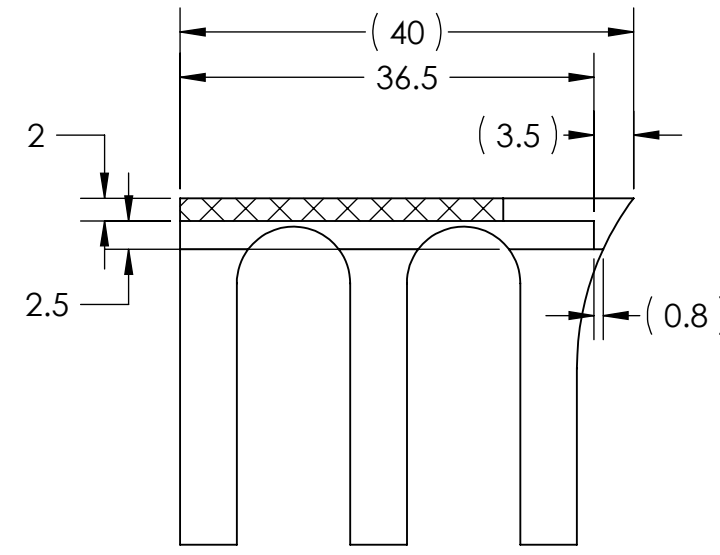
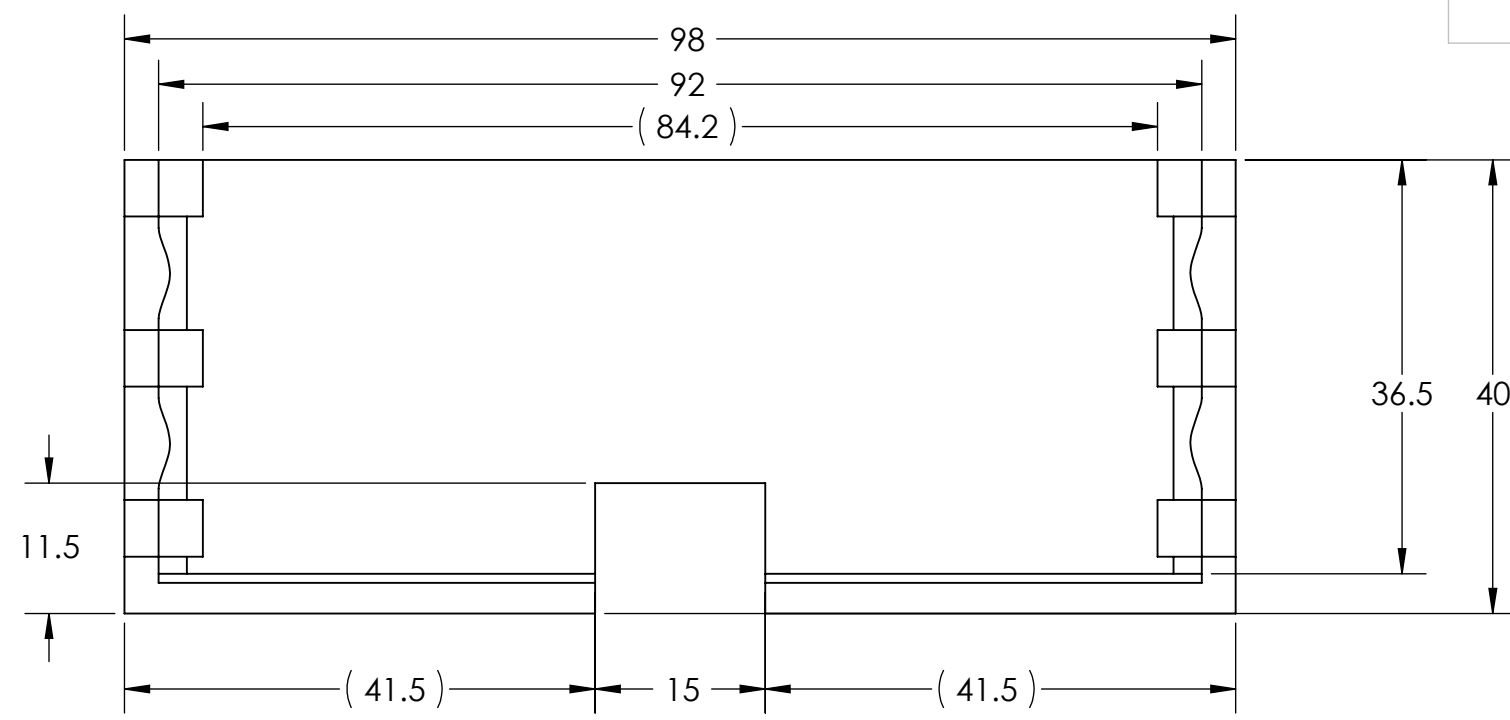

ENGRAVE PART NO. SEE NOTE 5

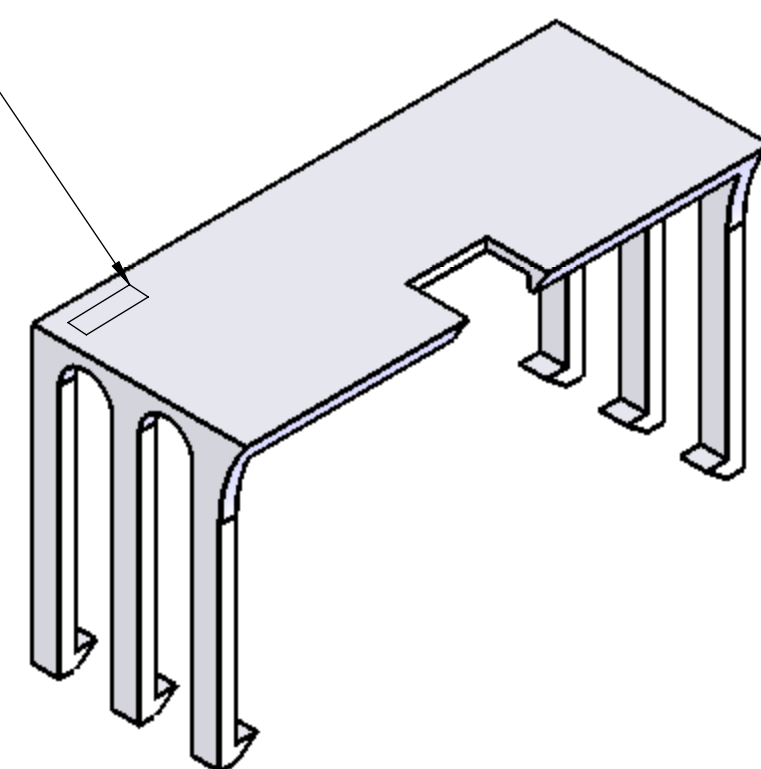

NOTES AND TOLERANCES: (UNLESS OTHERWISE SPECIFIED)

1. INTERPRET DRAWING PER ASME Y14.5-1994.
2. REMOVE ALL SHARP EDGES, R.2 MIN.
3. DO NOT SCALE FROM DRAWING.
4. ALL MACHINING FLUIDS MUST BE FULLY SYNTHETIC, FULLY WATER SOLUBLE AND FREE OF SULFUR, SILICONE, AND CHLORINE.

MATERIAL	PTFE (general)	FINISH	1.6 μm
-----------------	----------------	---------------	--------

LIGO CALIFORNIA INSTITUTE OF TECHNOLOGY
 MASSACHUSETTS INSTITUTE OF TECHNOLOGY

SYSTEM	ADVANCED LIGO	SUB-SYSTEM	SUS
NEXT ASSY			

PART NAME				FIBRE GUARD PTFE AWNING			
DESIGNER	L CUNNINGHAM	03/11/11	SIZE	DWG. NO.	D1102152	REV.	v3
DRAFTER	L Cunningham	04/11/11	c				
CHECKER	R.JONES	14/11/11	SCALE:	1.5:1	PROJECTION:		
APPROVAL					SHEET 1 OF 1		