

LIGO-AUSTRALIA

- ON THE CREST OF THE WAVE

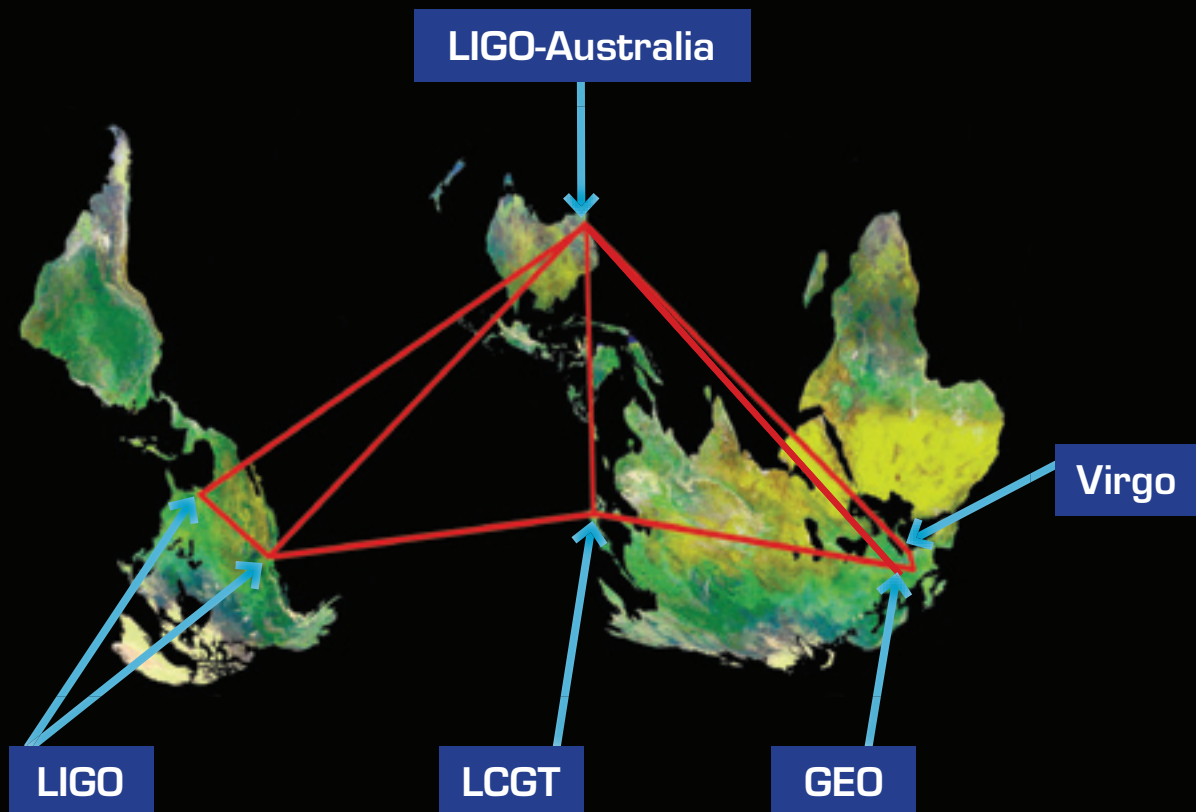

OPPORTUNITY AND CHALLENGE

The next decades will see a revolution in physics and astrophysics as a global network of ultra-sensitive gravitational wave detectors begin to harness the new spectrum of gravitational waves to probe the dark side of the universe. Australia can become a pivotal partner in this most challenging quest. The US LIGO Laboratory will transfer to Australia an advanced gravitational wave detector, valued at \$140M, provided Australia funds the construction of a national facility to house the detector (estimated to cost \$140M) and commits to funding operations for at least 10 years (operating costs estimated at \$6M p.a.). This offer has the approval and support of the National Science Foundation, the primary funding agency for Advanced LIGO, and the approval of the President's National Science Board, provided Australia makes a commitment by October 1, 2011.

**This Proposal is submitted by The University of Western Australia
on behalf of the member universities of the
Australian Consortium for Interferometric Gravitational Astronomy (ACIGA)**

**The University of Western Australia
The Australian National University
The University of Adelaide
Monash University
The University of Melbourne**



**THE UNIVERSITY OF
WESTERN AUSTRALIA**
Achieve International Excellence



THE AUSTRALIAN NATIONAL UNIVERSITY



**THE UNIVERSITY
of ADELAIDE**



MONASH
University



**THE UNIVERSITY OF
MELBOURNE**

For further information, please contact:

Professor Robyn Owens
Deputy Vice-Chancellor, Research

The University of Western Australia
35 Stirling Highway, Crawley WA
6009
Tel: +61 8 6488 2460
Email dvcr@admin.uwa.edu.au
Web: www.uwa.edu.au

Professor Stanley Whitcomb
LIGO-Australia Director (acting)

Adjunct Professor of Physics
The University of Western Australia

Chief Scientist, LIGO Laboratory
California Institute of Technology
Pasadena, California 91125 USA

Email: stan@ligo.caltech.edu

LIGO-AUSTRALIA: MOTIVATION AND EXECUTIVE SUMMARY

In the vast darkness of space, two black holes orbit each other, invisible as they creep inexorably closer. They are the remnants of massive stellar explosions more than a hundred million years ago, objects so dense that not even light itself can escape the grip of their gravitational pull. When they reach a separation of only 100 km, they are moving at nearly half the speed of light, distorting nearby space and time in almost unimaginable ways. In a final rush lasting only seconds, they spiral together, merging to form a single black hole which vibrates rapidly for a fraction of a second, and then settles into its final quiescent state, never to be seen or heard again.

This entire drama plays out in darkness—no light or x-rays or radio waves mark the end of this dance. Yet, in the final seconds before their collision, these two black holes emit more energy than all the stars in the observable universe—in a strange form of radiation called gravitational waves. First predicted by Einstein in 1916 as a part of his General Theory of Relativity, gravitational waves are enigmatic, carrying great energy, yet producing infinitesimally small effects as they pass through space at the speed of light. They are of great importance to fundamental physics, and of growing interest for astronomy as a means to study astrophysical phenomena beyond the reach of electromagnetic waves, such as the growth of black holes and the earliest moments of the big bang.

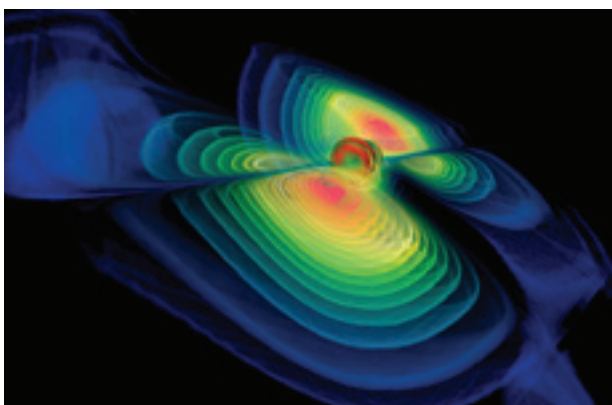

Gravitational waves from colliding black holes.
Credit: Werner Bengler

In the coming decade, an international network of multi-kilometer scale gravitational wave detectors will come into operation in the US, Europe and Japan. Working together, these ultra-sensitive detectors will begin to unravel the mysteries of gravity as a fundamental force, elucidate the astrophysics of gravitational wave sources, and probe the quantum limits to measurement.

Fundamental questions will be answered such as:

- Is Einstein's General Theory of Relativity the correct description of gravity, or is it incomplete, as some have suggested?
- How common are black holes, and how are they distributed in the universe?
- What is the structure of neutron stars and how do they evolve?
- What is the mechanism that causes a collapsing star to become supernova?
- How do the laws of quantum mechanics apply to the macroscopic objects in our everyday life?

In collaboration with the world-leading Laser Interferometer Gravitational-wave Observatory (LIGO), the Australian Consortium for Interferometric Gravitational Astronomy (ACIGA) proposes to establish the crucial Southern Hemisphere node in this network at Gingin in regional Western Australia.

DESCRIPTION OF THE PROJECT

The US-based LIGO project is the largest and most advanced of the international gravitational wave detector efforts. LIGO has embarked on an ambitious program to upgrade its US detectors incorporating advanced technologies (high power precision lasers, ultra-precise optics, low-noise vibration isolating platforms, grid-based supercomputing) developed over the past decade by an international team including scientists from Australia. The "Advanced LIGO" detectors will be a factor of 10 more sensitive than the pioneering first generation detectors, and will transform the field from one of gravitational wave detection to one of gravitational wave astrophysics. LIGO is funded to build three Advanced LIGO detectors in the US. Its original plan (developed nearly a decade ago) was to install one detector at its site in Louisiana and two detectors in its facility in Washington State.

As the era of gravitational wave astrophysics nears, there has been increasing study on how to achieve the maximum science for the available investment. In 2008, the pre-eminent international body in the field, the Gravitational Wave International Committee (GWIC), chartered a committee to prepare a Roadmap for the next decades, with this goal in mind. Their strongest recommendation was that the community needed to find a way to expand the global network to include a Southern Hemisphere detector. Acting on this recom-

mentation, the LIGO Laboratory decided to explore the option of shifting one of the Advanced LIGO detectors from the US to a southern hemisphere location, identifying Australia as by far the best option because of its position with respect to the existing detectors, its past contributions to gravitational wave science, and its role as a partner in Advanced LIGO.

It is proposed that a complete Advanced LIGO detector be transferred to Australia, to be installed in a facility built and operated by Australia, as the Southern hemisphere node in the network. This proposed project is called LIGO-Australia.

The scientific benefit of LIGO-Australia is transformational. Among the first questions that must be answered about each gravitational wave observed is where it comes from on the sky. The international detector network answers this question by comparing the signals at widely separated detectors. The addition of LIGO-Australia to the international network offers a significant improvement in establishing the sky location of gravitational wave sources. Depending on signal to noise and the location on the sky, the accuracy of the position of a source can be 5 to 10 times better with LIGO-Australia than without it. In many places on the sky, using reasonable signal to noise, the uncertainty in position approaches 1 square degree; sufficiently small to enable

electromagnetic astronomical identification of the source. This will enable gravitational wave sources to be studied using the tools of multimessenger astronomy such as the Square Kilometer Array (SKA) radio telescope.

With this facility, Australia would become one of the leading nations in the field of gravitational waves, with a state-of-the-art detector. The unique location of LIGO-Australia will give it high visibility and importance as a member of the international network.

LANDMARK QUALIFICATION

LIGO-Australia is truly a Landmark Project, by all definitions. The science is bold and inspiring—the first detection of gravitational waves will make front page headlines around the world as the confirmation of a prediction made nearly 100 years ago, and the subject of a 50 year quest to observe experimentally. This first observation will also open a new window in astronomy, with all the surprises and potential that brings. LIGO-Australia will enable Australian scientists to participate in decades of Nobel Prize-winning discoveries.

The facility is also “Landmark” in physical size. Two 4 km arms stretch at right angles. The largest ultra-high vacuum system in the southern hemisphere will house the detector to protect it and the sensitive paths for the laser beams from even the tiniest disturbances. The challenges of making such measurements requires the most sophisticated technologies in lasers, optics, vibration isolation, electronics, computing and data handling, and engineering. Spin-offs to other science, engineering and industrial applications will provide commercial opportunities for Australian industries and businesses in collaboration with universities and funding agencies. These have the potential to more than compensate for the investment.

The community in Australia involved directly and indirectly in gravitational wave research, technology, technological spin-offs, education and training numbers about 150. Those directly involved in this proposal (about 50) consist of academics and researchers at the five Go8 Universities represented in the Australian Consortium ACIGA. Based on LIGO’s experience, it is estimated that the number directly involved will multiply at least 4-fold to 200 within the first 5 years of this project, while the number involved in spin-offs, education and training is likely to increase commensurately. Further increases will follow once gravitational wave signals are regularly detected. Numbers will be boosted by a substantial number of visiting personnel from the international collaboration partners discussed later.

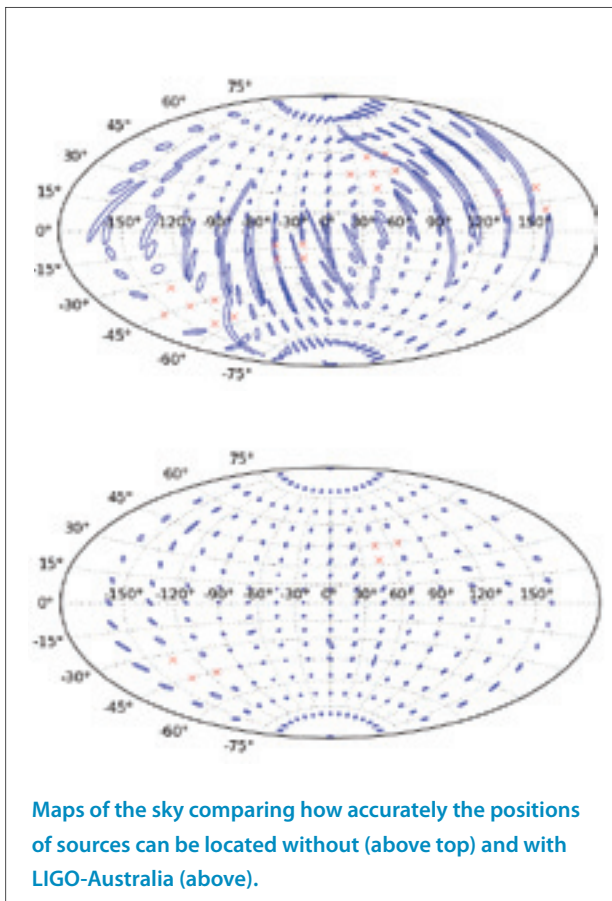

The international endeavour has been growing steadily and now numbers well over 1000 scientists, engineers, and students in more than 15 countries. The first confirmed detection will only accelerate this growth, as the potential of gravitational wave data to be used in astronomy, cosmology, relativity and quantum measurements becomes known.

LIGO-Australia is also “Landmark” in terms of cost. The facility and the detector are estimated to cost approximately AU\$280M in the construction phase. The US contribution, the detector design and hardware, is approximately half (subject to exchange rate variations), leaving the required Australian contribution at AU\$140M. Operating costs after the completion of construction are estimated at AU\$6M per year, and would be expected to continue for at least 10 years.

“Of all the large scientific projects out there, this one is pushing the greatest number of technologies the hardest.

“Every single technology they’re touching they’re pushing, and there’s a lot of different technologies they’re touching.

“The initial decision to go forward with LIGO was tremendously bold because, at the time, only a few people thought it was even technologically feasible.”

Beverley Berger,
Program Director for Gravitational Physics,
National Science Foundation

Quoted in Business report.com, Steve Sanoski 13 Dec 2010

It is important to note, however, that the costs in the first year (2011-2012), which are needed to support the engineering and architectural design, are AU\$7M.

AUSTRALIAN NATIONAL PRIORITIES

LIGO-Australia will support research in the key National priority area of Frontier Technologies for Building and Transforming Australian Industries, whilst being a vehicle for the national innovation agenda in physics and engineering. It will not only enable training of scientists and engineers in high technology areas but its profile and the activities undertaken by its staff will help revitalize the physical sciences in Australian schools. LIGO-Australia also has significant crossover impact on two other national research priority areas, “An Environmentally Sustainable Australia” and “Safeguarding Australia.” The project is strongly in-line with the National Innovation priority “increasing international collaboration in research” and is consistent with DIISR factsheet International Science and Research Engagement.

CURRENT STATE

The partnership with LIGO moves this project to a state of readiness that normally takes years to achieve. There is a strong Australian community which has been participating in the LIGO Scientific Collaboration for years, with active research at all five universities and at a prototype scale facility built by ACIGA at Gingin. They stand ready to take responsibility for building the necessary facility, installing, and commissioning the detector from LIGO and fostering the broader engagement of the Australian scientific community.

The Advanced LIGO detectors have undergone years of research and design, and the LIGO Laboratory and its partners (UK, Germany, Australia) have begun fabricating the components for the three Advanced LIGO

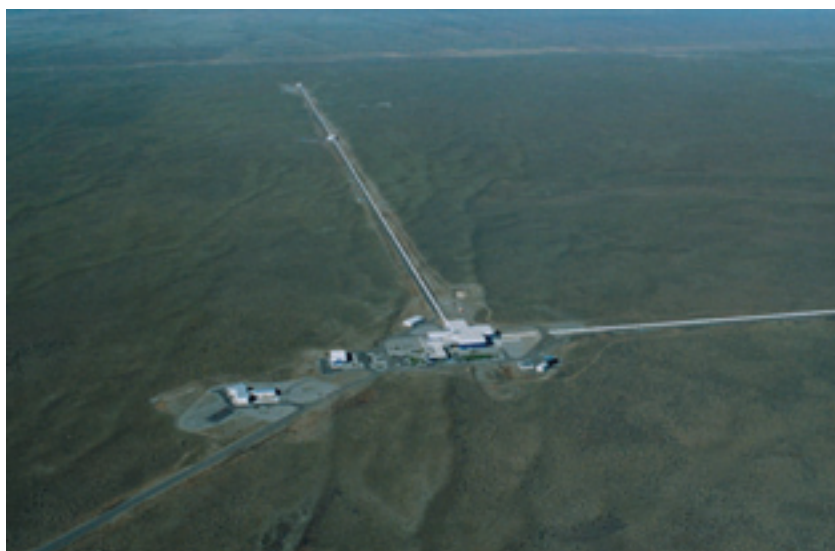

The LIGO Facility at Hanford, Washington.

detectors. The US National Science Foundation (Advanced LIGO’s main sponsor) has already given approval to transfer the components to Australia. The facility needed is well-defined based on the LIGO model, and construction could be underway after a brief period to adapt the designs to Australian standards of construction. A detailed cost estimate for the Australian component has been made and reviewed by LIGO for completeness and accuracy. The five ACIGA universities have signed an MOU indicating their agreement to collaborate to build and operate LIGO-Australia.

We have a compelling science case, a proven design, capable participants, and strong institutional support. In short, we are ready to begin in earnest as soon as funds can be raised.

THE CHALLENGE

The field of gravitational wave astrophysics is evolving rapidly and quick action will be required to bring LIGO-Australia into existence on a timely scale. In the last two years, the Northern Hemisphere portion of the international network has been filled in with the beginning of Advanced LIGO funding (2008), approval of Europe’s Advanced Virgo (2009), and the initial funding for the Large Cryogenic Gravitational-wave Telescope (Japan, 2010).

To join this network will require immediate and decisive action by Australia. LIGO has offered a complete Advanced LIGO detector (one of two originally planned for LIGO’s Washington State site), but this offer must be taken quickly. This detector is scheduled to begin

installation in its US facility near the end of 2011. If Australia cannot make a commitment to build the facility to house it by October 1, 2011, LIGO will be forced to withdraw this offer and to install the detector at Hanford as planned. If Australia can make this commitment, the strawman schedule and supporting budget profile shown below shows that LIGO-Australia can be operational by 2017, and can join in the excitement of early detections only a short time after the US LIGO detectors come into operation.

ACIGA proposes a joint funding package for the Australian component of LIGO-Australia involving the Federal Government, the WA Government, ACIGA universities and international partners.(see below) We note that this is a unique international collaboration where all Australian sourced funding will be spent in Australia, with very significant multipliers in terms of total economic benefit.

ACIGA has signed MOU’s with Consortia in India and China who propose to participate in LIGO-Australia. Seed funding has been received from the DIISR, DST in India and the Australia China Council. A proposal for a substantial Indian contribution is being lodged in parallel with this proposal. The cost summary below does not take into account the cost savings from international contributions. *A detailed cost schedule is available from the applicants.*

We have a great opportunity, but if we cannot act quickly, it will close.

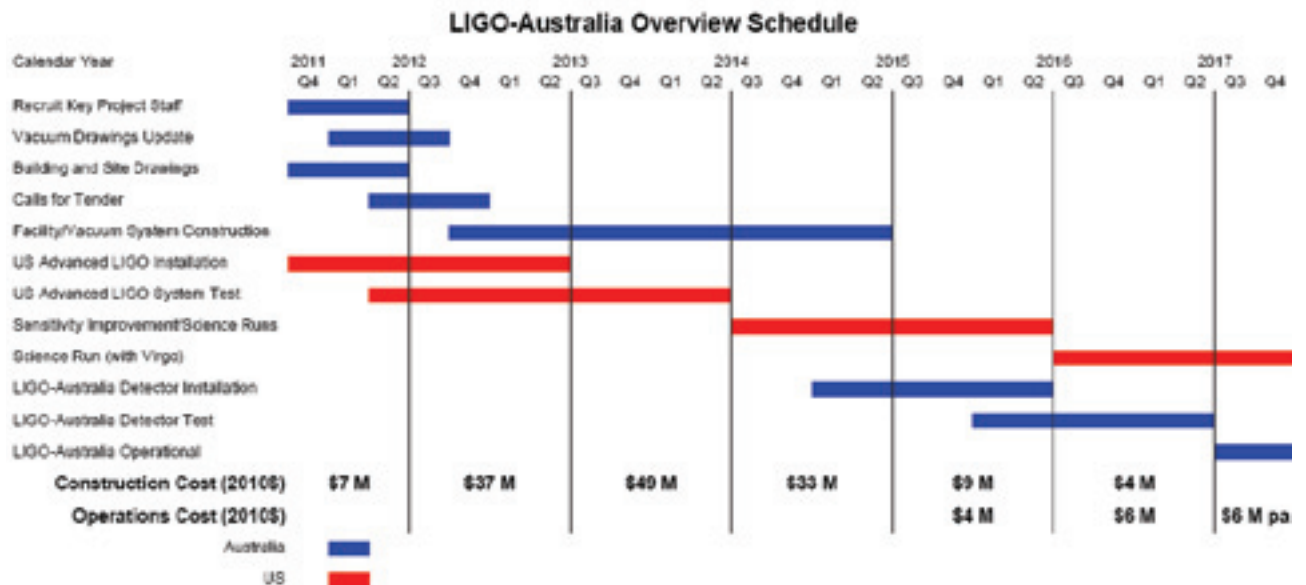

LIGO-AUSTRALIA

- ON THE CREST OF THE WAVE

CONTENTS

	EXECUTIVE SUMMARY	i
1.	PROJECT DESCRIPTION	1
	1.1. The challenge of gravitational wave detection	1
	1.2. The LIGO-Australia detector	3
	1.3. The LIGO-Australia facility	6
	1.4. The LIGO-Australia site	8
	1.5. Operational Phase	9
	1.6. Collaborator responsibilities	9
2.	ACADEMIC AND INNOVATION CASE	11
	2.1. Physics and Astronomy: A new spectrum ushers in a new era of exploration	11
	2.2. Technology Innovation: Breaking new ground in precision sensing	19
	2.3. Creating Educational Opportunities with LIGO-Australia	22
3.	RELEVANCE TO AUSTRALIAN NATIONAL PRIORITIES	25
	3.1. National Research Priorities	25
	3.2. National Innovation Priorities	28
	3.3. National Education Priorities	30
	3.4. National Environmental Priorities	32
4.	COLLABORATION	35
	4.1. Current LIGO-Australia Collaborators	35
	4.2. Potential Future Participants	37
	4.3. Linkages	40
	4.4. Governance	41
5.	PROJECT FEASIBILITY AND BUDGET	45
	5.1. Technical feasibility	45
	5.2. Schedule	46
	5.3. Costs and Funding	48
	5.4. Risk matrix and risk mitigation	57
6.	REFERENCES	55

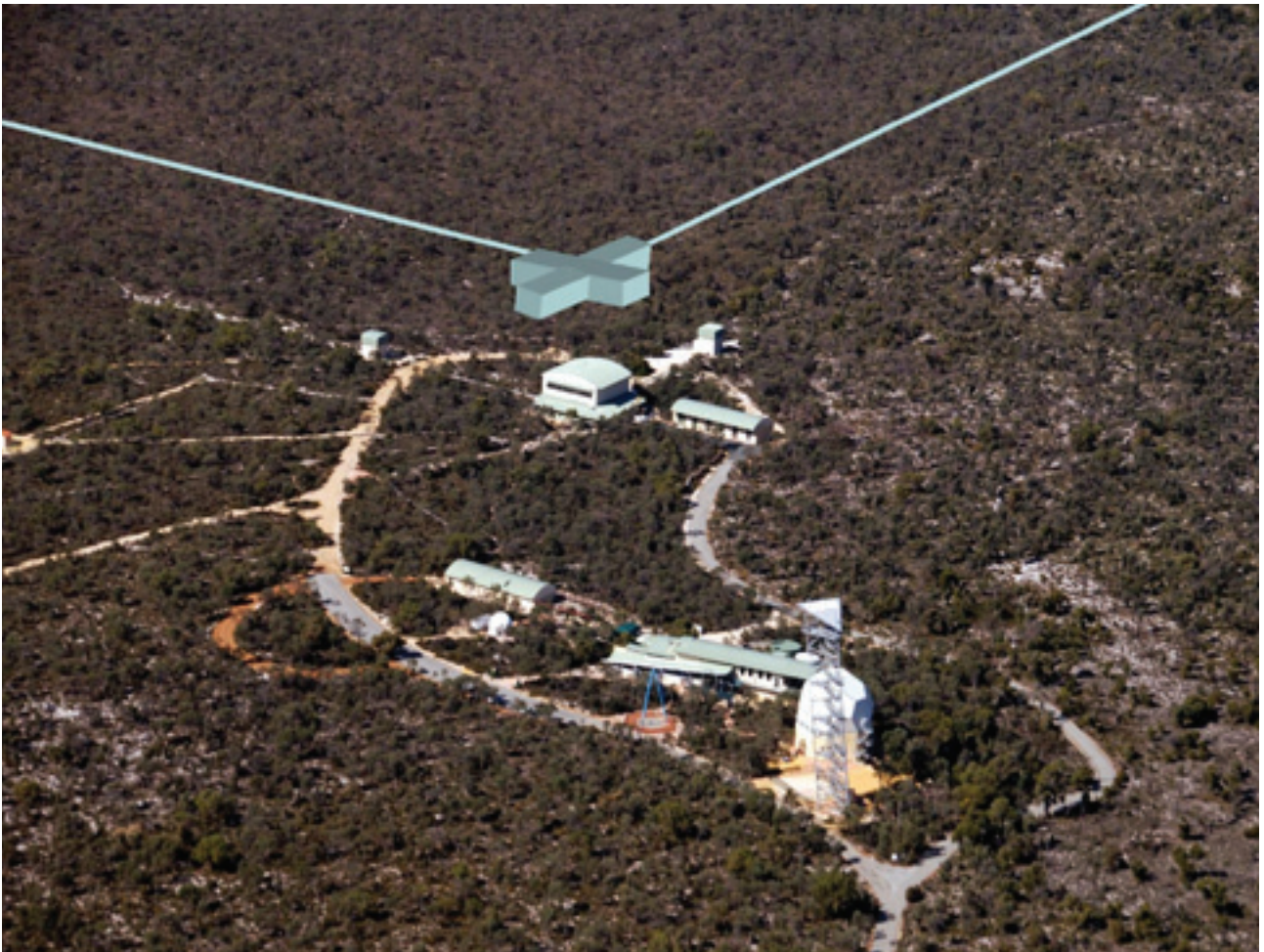

A visualisation of the LIGO-Australia detector on the Gingin site in Western Australia.

1 LIGO-AUSTRALIA: PROJECT DESCRIPTION

We propose to build a state-of-the-art gravitational wave detector at Gingin in regional Western Australia, based on proven hardware of the US Advanced LIGO instrument.

This ultra-sensitive detector will be a critical part of a global array to detect and use gravitational waves in a new astronomy, and will permit a broad swath of Australian physicists and astronomers to participate in this emerging field. The project will be a collaborative effort between Australia and the US as a continuation of more than a decade of very successful collaboration between LIGO and ACIGA. (For the detailed explanation of these organisations, please see Section 5 on Collaborations). LIGO has built its first generation detectors, meeting and exceeding all technical goals. They have embarked on a second generation detector, known as Advanced LIGO², and by partnering with them, Australia will become one of the major participants in this exciting science, as well as derive tangible benefits in terms of advanced technology, education and research linkages.

In this section, we first review the method we propose to use to detect gravitational waves and the challenge that it presents. For a comprehensive description we refer the reader to the GWIC roadmap* and the references therein. We then describe the LIGO-Australia detector³, which is the product of more than a decade of R&D. We proceed to describe the facility, which is required to house it, and the engineering challenges it presents. We conclude by describing briefly the site, the operations phase and the division of responsibilities between the Australian and US collaborators.

1.1 THE CHALLENGE OF GRAVITATIONAL WAVE DETECTION

Just as Maxwell's equations predict electromagnetic waves, so Einstein's field equations of general relativity predict gravitational waves: time-varying distortions of space-time which propagate through space at the speed of light¹.

Due to the absence of negative mass, gravitational waves are quadrupole waves: they arise from time varying mass quadrupole moments. Like electromagnetic waves, they are purely transverse waves with two polarizations (Figure 1.1). Gravitational waves are produced by essentially all accelerating masses, primarily through the change in the mass quadrupole. However, because of the weakness of the gravitational force (compared with other fundamental forces) producing a detectable gravitational wave requires huge masses, of the order of our sun or larger, and accelerations capable of producing very large velocities, approaching a significant fraction of the speed of light. In practical terms, these occur only for compact astrophysical objects including black holes and neutron stars, or cataclysmic events such as supernovae and even the Big Bang. In spite of carrying large energies, even the strongest predicted gravitational waves for LIGO-Australia create infinitesimal strains in space, at most 10^{-21} .

We can detect a gravitational wave by measuring the change in separation of free masses along the two polarization axes. The strength of a gravitational wave is given by its amplitude h , which is the fractional distortion of space which it produces, related to the change in separation of two test masses caused by the wave divided by their initial separation, $h = \Delta L/L$. While the gravitational wave shown schematically in Figure 2.1 has an amplitude $h \approx 0.2$. An actual gravitational wave might produce a strain in the detector's arms (the fractional change in length of the arm) of just 10^{-22} .

The corresponding change in arm length caused by a gravitational wave will be on the order of 10^{-19} metres, or 1/10,000 the diameter of a proton⁴.

* <http://gwic.ligo.org/roadmap>

A gravitational wave impinging on a ring of free masses in a plane perpendicular to the direction of travel alternately stretches and squeezes space itself, causing the circle of masses to distort into an ellipse alternating along the two axes.

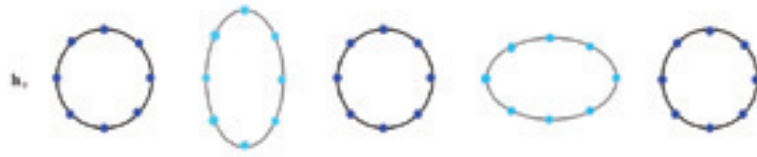

Gravitational waves are quadrupole waves and exist in two identical polarizations rotated by 45 degrees around the direction of propagation. The direction of polarization provides important astrophysical information.

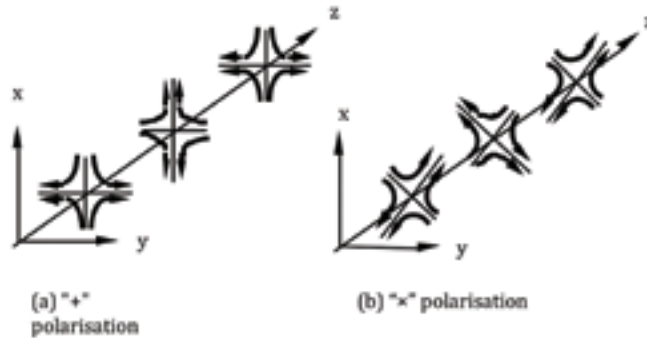

Figure 1.1 Gravitational waves distort space-time, deforming the positions of test masses (above), and generating force fields in two polarisations (below).

The most promising technique for direct detection of gravitational waves is long baseline laser interferometry. A Michelson interferometer has an ideal geometry to compare the strains along the two axes perpendicular to the direction of travel of the wave (Figure 1.2), and offers the high sensitivity associated with an interferometric measurement⁵. Moreover, one can make the arms long to increase the motion of the mirrors relative to one another and thus increase the sensitivity to h . Even so, with kilometer scale arms and a typical laser wavelength of 1 μm , the required sensitiv-

ity corresponding to a change in arm length of better than 10^{-19} metres is less than 10^{-13} of the wavelength of the laser. Furthermore, we must protect the mirrors from any spurious (non-gravitational wave) sources of motion at the level of less than 10^{-19} m. This is the challenge of gravitational wave detection, one which has been driving precision measurement science for more than three decades.

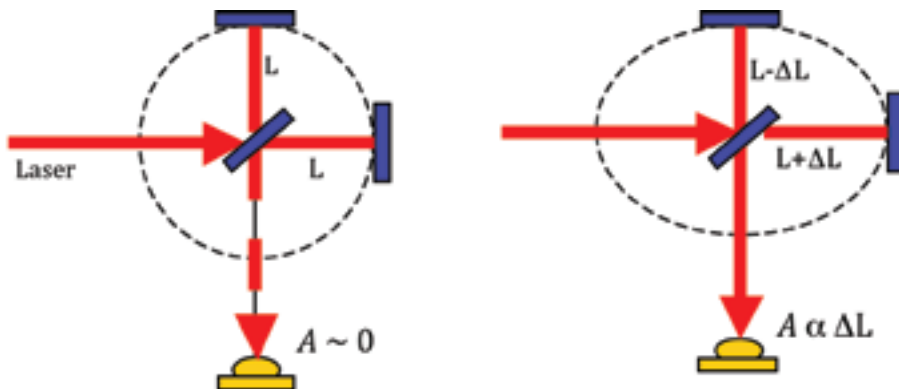

Figure 1.2 Gravitational waves can be detected using laser interferometers to probe the distortion of space. The optics of a Michelson interferometers can act as the test masses in Figure 1, resulting in a relative change of the lengths of the arms of the interferometer. The change in length results in a change in the transmitted light at A.

1.2 THE LIGO-AUSTRALIA DETECTOR

To achieve the required sensitivity, the LIGO-Australia interferometer will be a sophisticated elaboration on the basic Michelson interferometer shown in Figure 1.3. We start with the highest power laser that can be stabilised to the required level. Optical cavities in each arm reflect light back and forth between mirrors, building up the light intensity and increasing the phase shift for a given physical change in arm length. The interferometer achieves its best sensitivity when the phase of the light returning to the beamsplitter is such that the light on the photodiode is near a minimum. This results in the majority of the light returning toward the laser. Another partially transmitting mirror, called the power recycling mirror, is positioned between the laser and the beamsplitter creating yet another optical cavity and further increasing the power in the interferometer. When a gravitational wave passes through the detector a tiny fraction of light from the arms is directed out

toward the photodetector. In a technique which is well proven but non-intuitive, it is possible to improve the sensitivity of the detector by placing a suitably-chosen partially-reflective mirror (the signal recycling mirror) between the beamsplitter and the photodetector. This forms a resonant cavity for the signal light, and increases the signal build-up. Finally, the light leaking through the signal recycling mirror strikes the photodetector, where it is recorded and processed by computer. This configuration is called a dual recycled interferometer⁶.

To maintain optimal operation, all interferometer optics must be accurately aligned and located, in some cases with a precision of better than 10^{-13} m. Sophisticated digital servo control systems are used to maintain correct alignment and positions without introducing extraneous noise. The lock acquisition system, which is used to initially position all the interferometer optics in this multivariable system, is being developed and delivered by The Australian National University as their contribution to Advanced LIGO.

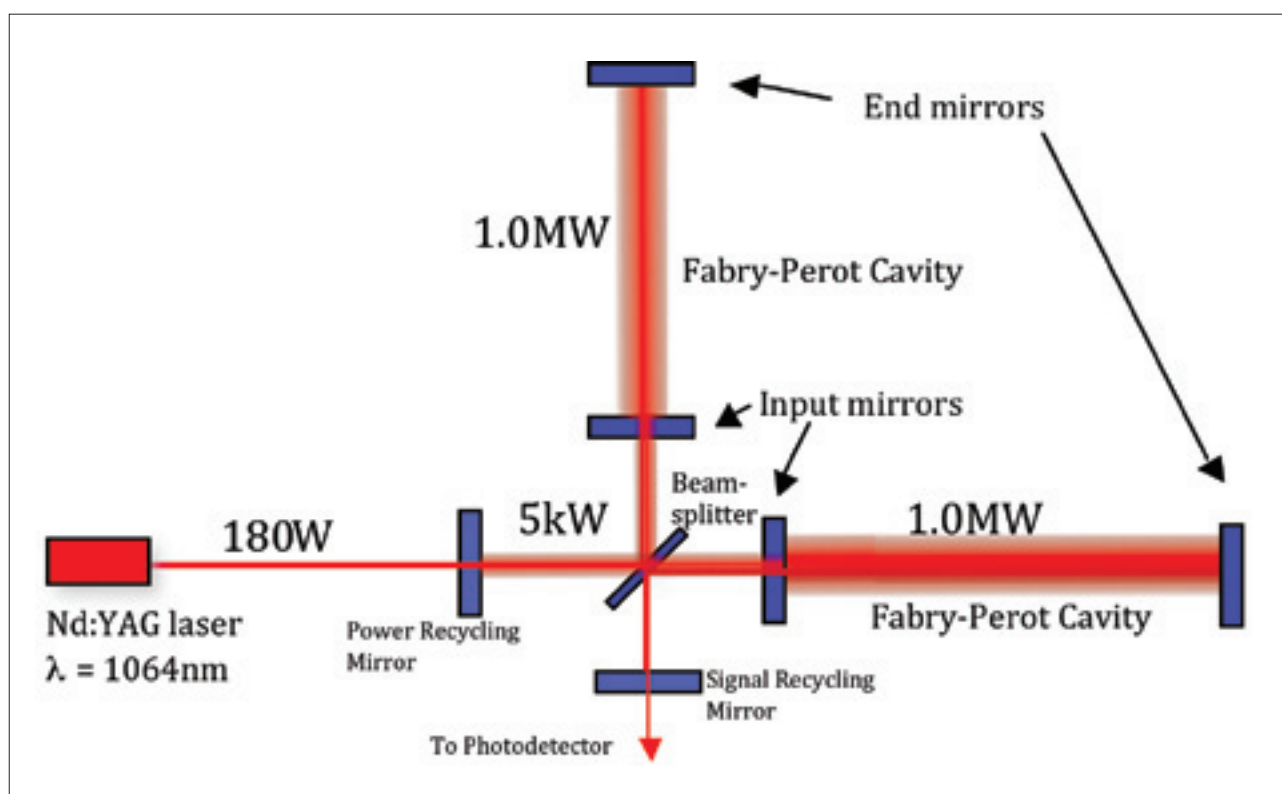
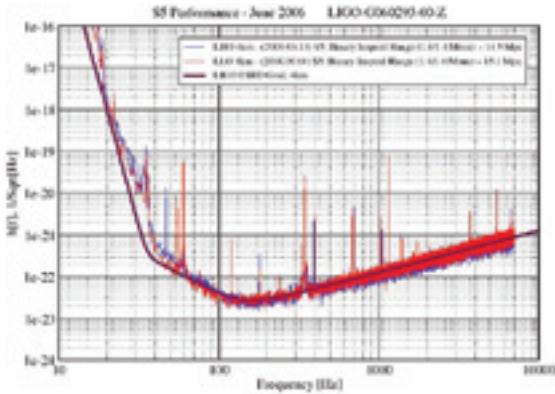

Figure 1.3 Schematic optical design of Advanced LIGO detectors:

Design features include the dual recycled configuration with Fabry-Perot arm cavities, a power recycling mirror, a signal recycling mirror and a high power laser. The best sensitivity occurs when the optical power on the photodetector is minimum, and this allows power recycling of the laser to reach stored optical power levels of 1MW. These improvements enable the sensitivity to reach $\Delta L/L = 10^{-22}$

Initial LIGO reached its design sensitivity (black line) of $h = \Delta L/L < 10^{-21}$ in 2005 (blue: Hanford, red: Livingston).



The parameters influencing the sensitivity are fully understood, and the improvements in sensitivity of Advanced LIGO are directly traceable to known technology. The improvements required in each subsystem are indicated, resulting in the overall sensitivity of Advanced LIGO (solid pink line) compared to the achieved sensitivity of Initial LIGO (black dotted line)

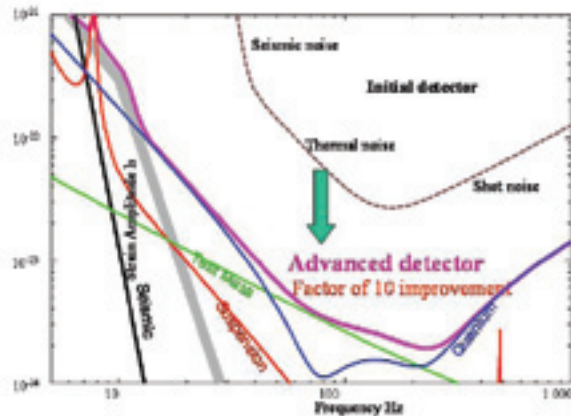

Figure 1.4 Initial LIGO has been a great success, and has shown that it is feasible to reach the sensitivity required.

The 4 km initial LIGO detector, based on a simplified version of the above design, in 2005 reached its design sensitivity goal (set 15 years earlier) as shown in Figure 1.4. Having demonstrated this technological feat, the next step is to upgrade the detector to the Advanced LIGO, with a ten times better sensitivity leading to near-certain detection of frequent gravitational wave events. With new high power lasers, improved test mass material and coatings, advanced vibration isolation systems, and new detector configurations, such sensitivity is now attainable and the upgrade is in progress: the Advanced LIGO detectors are now under construction, and LIGO-Australia will be such a detector. The improved predicted design sensitivity is shown in Figure 1.4.

Needless to say, the extreme sensitivity of this interferometer places extraordinary demands on system components, including:

Pre-stabilized laser: The laser must have high output power, extremely low frequency and intensity noise, and be able to operate stably for long periods of time. This will contribute to the increase in stored optical power and hence the indicated reduction by a factor of ten in shot noise at high frequencies. The state-of-the-art laser system, developed and provided by Lazer Zentrum Hannover⁷ and the Max-Planck Institute⁸ as the German contribution to Advanced LIGO, produces 180W of power (Figure.2.5). It consists of a stable master oscillator laser, a 35 W amplifier followed by a high power injection locked oscillator. It also includes a pre-modecleaner, a high power mode cleaner and control and diagnostics systems for the laser. It is stabilized to a level of $10^{-9}/\sqrt{\text{Hz}}$ in intensity and to $10^{-7}\text{Hz}/\sqrt{\text{Hz}}$ in frequency.

Core optics: The core optics consist of the four 40kg fused silica test masses, the suspended beam splitter, the recycling mirrors (power and signal) and the thermal compensation plates. The test masses and the beam splitter have very stringent requirements on optical homogeneity, surface figures, coatings and bulk absorption. Typical precision for surface figure is $< 1\text{nm}$ (that is $\lambda/1000$, about 100 times better than required in most conventional high quality optics) and coating losses (scattering and absorption) must be correspondingly low (typically $10^{-5} - 10^{-6}$). A number of the Advanced LIGO optics are being coated at CSIRO⁹ (see also sec. 3.2.1 Lasers and Optics).

Thermal compensation system: In spite of the stringent demands on the optical coatings, thermal distortions of the optics in the presence of the high circulating powers in the arms are expected to be too large to accommodate. To compensate for these distortions, an active system which monitors the surface figure using a set of Hartmann wavefront sensors, will give real time correction by feed-back to the mirrors using ring heaters, thermal compensation plates and CO_2 laser heater systems. The Hartmann wavefront sensors were developed by the University of Adelaide as their contribution to Advanced LIGO (see also sec. 3.2.1 Lasers and Optics).

Isolation against disturbance: Another challenge in gravitational wave detection using laser interferometry is to prevent any non-gravitational source from moving the surface of the mirror. These include acoustic and seismic vibrations, electric and magnetic fields, and even thermal vibrations of the mirror and its suspension. This is achieved by enclosing the entire detector in a vacuum system, and by suspending the most sensitive optics on vibration isolators, designed to absorb all vibrations that could otherwise reach the mirrors.

The vibration isolators developed for gravitational wave detection are the most advanced in the world and have many wider applications.

Vibration isolation system: Three separate systems contribute to the vibration isolation¹⁰. A hydraulic external pre-isolator provides large actuation range and low frequency isolation. An active internal isolation system uses seismometers and geophones to provide six-degree-of-freedom isolation over a broad frequency

range. The final system is a four stage passive isolation system carefully designed with a monolithic fused silica suspension to minimize thermal noise. The fused silica suspensions systems have been designed and supplied by the UK as their contribution to Advanced LIGO. The different stages have been developed to optimize the overall isolation of the test masses from the environment, and the final system represents the state of the art in isolation today.

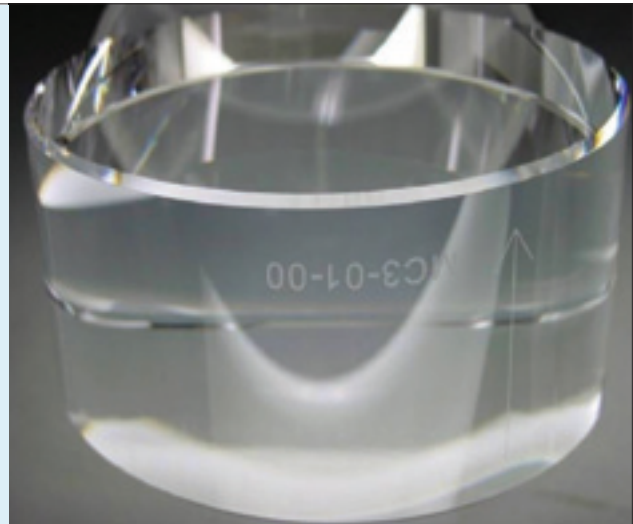
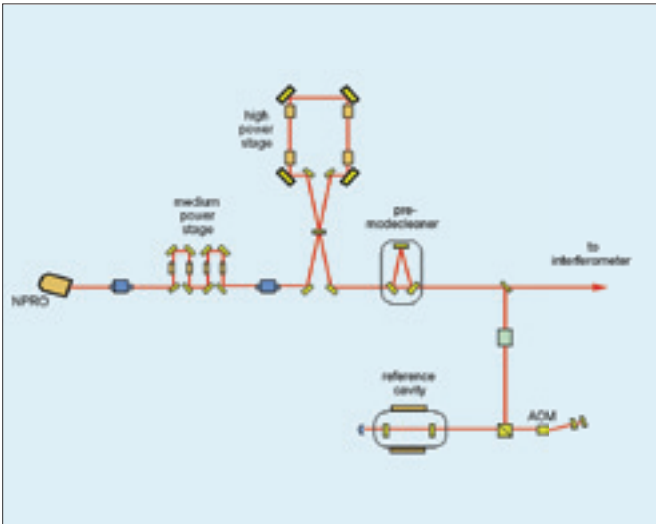

a) Prestabilized laser will be upgraded to 180W

b) A thermal compensation system will correct for distortions of the core optics due to the high optical power.



c) The new vibration isolation system includes of a hydraulic pre-isolator and an active internal isolator.

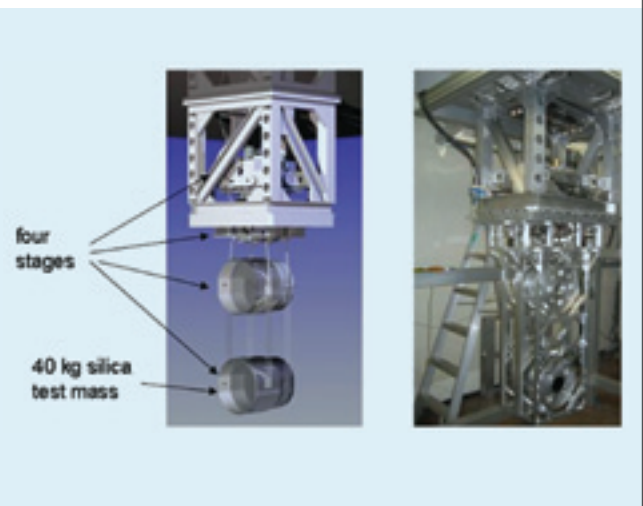

d) The test masses will be suspended from a four stage passive isolator.

Figure 1.5 The improved sensitivity of Advanced LIGO will be reached by improvements in many subsystems.

1.3 THE LIGO-AUSTRALIA FACILITY

To house and operate this detector requires a facility meeting stringent and specialised requirements.

The construction will in itself be a substantial engineering project, building Australian capability in the latest developments in large vacuum system engineering, welding techniques and technology.

The vacuum system: This is by far the largest and most critical single component. Without an excellent vacuum system the interferometer cannot work, and this system also forms the visual envelope and backbone of the instrument. The LIGO vacuum systems are amongst the largest in the world, with a pumped volume of 10000m³ (10Mega-litres), evacuated to an ultra high vacuum of 10⁻⁹ torr¹¹. Building the vacuum system will include manufacturing the beam tubes, the tanks and all the essential vacuum components and pumps as well as the subsequent assembly, baking, leak checking and testing of the completed system.

We will manufacture the large beam tubes on site to avoid complicated and expensive transportation. The magnitude of this task can be appreciated by studying Figure 1.6, showing part of the spiral weld machines which must be constructed on the site and some of the tubes and tanks produced for LIGO.

A total of about 1000 tons of specially processed 304L stainless steel is required, delivered in 3mm thick, 0.75m wide coils. These will be formed into a helix and spiral welded into tubes, 1.2m in diameter. Each 20m length will be fitted with stiffening rings on the outside and optical baffles inside. The total weld length for the whole system is about 50km, and it must be completely free of any leaks. The 20m tube length from the mill must be butt welded together with expansion bellows at 200m intervals and ports in the sides for residual gas analysis (leak checking). Large flanges each 2km, to accommodate large 1m gate valves, are required to isolate sections for bake-out and for installation of the tanks. In addition, the large optics tanks, vacuum pumps gate valves and much peripheral vacuum system components and leak checking equipment must be procured and installed.

The vacuum system will require real time quality control by experienced engineers and physicists, including vacuum leak checking, residual gas analysis and baking of the sealed system.

A special beam-tube mill will be built on site to produce the two 4km, 1.2m diameter beam tubes, shown here producing a section of the tube.



The finished vacuum system will be the largest in the Southern Hemisphere. Tanks containing core optics.



Spiral welded beam tubes will be protected from the environment.



Figure 1.6 Producing the vacuum system will develop new capability in Australia.

Site buildings: The detector is housed in three main buildings—a very large corner station and two smaller end stations. These buildings are high quality, clean and temperature regulated buildings to house the instrument. The corner station has approximately 1800m² of high bay space covered by overhead cranes with a hook height of more than 8m. Strict temperature control and cleanliness are essential. The functional requirements and floor plans are based on the LIGO buildings, but must be adapted to the site and to Australian building standards. The designs for the foundations, floors and body must minimize noise and vibrations, both from the air conditioning fans and outside wind.

In addition we require tube covers for the long vacuum arms to complete the instrument enclosure. The LIGO use detectors concrete arches (Figure 1.6) which appear to be prohibitively expensive in Australia. We intend to use a lower cost alternative enclosure. The preferred design embeds the tube enclosure partially in the sand, with the tubes resting on individual piers as opposed to a long cast foundation, protected by a secondary U-shaped culvert section construction. The beam tube foundations must be ready early on to receive the finished tube sections as they come off the mill. The rest of the buildings will be built mostly in parallel with the construction of the vacuum system, so that they are ready once the vacuum tanks and remaining system are ready for installation.

Cleanliness is one of the over-arching concerns for optics in high vacuum systems. The optics must remain ultra clean from any hydrocarbon contamination and free of dust which can act as scattering or absorption centers in the high power laser beam.

To accomplish this we use a system of successively cleaner embedded spaces. The overall interferometer building is built with a special air-conditioning system using HEPA filters to remove nearly all dust particles. Whenever the vacuum system is opened, portable clean rooms are erected around all openings. The vacuum system itself is supplied with ultra-clean air and is over-pressurized to prevent any remaining dust particles from entering. Such techniques are applicable to many other areas, such as semiconductor manufacturing, space hardware preparation, etc.

Additional buildings house the control room, the computers, the personnel offices, and general support. Some of the requirements for detector assembly will be provided by the existing corner building of the Gingin High Optical Power Facility (but there will also be a need to build a large, temporary beam-tube manufacturing shed. These buildings are built to conventional office, laboratory or workshop standards, as appropriate.

A large central building, comparable to the LIGO building shown (but utilizing many sustainable energy features: see section 4.4) will contain detector, assembly areas and control room.



The detector must be assembled under ultraclean conditions as illustrated in the two images below.



Figure 1.7 The detector will be housed in high quality clean and temperature regulated buildings, similar to those at the LIGO observatories.

1.4 THE LIGO-AUSTRALIA SITE

An ideal site, located in regional Australia near Gingin, about 80km N of Perth has been set aside by the WA Government, and reserved for LIGO-Australia under a lease with UWA.

It is currently the home of the ACIGA high optical power facility¹² (HOPF, an 80m instrument operated by The University of Western Australia to test interferometer behaviour under power levels scalable to Advanced LIGO), a 1m robotic telescope¹³, and a public education centre, the Gravity Discovery Centre (GDC). Locating LIGO-Australia at this facility allows maximum synergy with the educational programs and use of existing research space.

The Gingin site was chosen following a site selection process, including aerial surveys, photogrammetric terrain surveys, environmental surveys, and seismic measurements. Site selection was based on a number of factors including remoteness, flatness, deep silica sand for stability and attenuation of local seismic noise. Sec-

ondary considerations were accessibility, availability of power and water, and support of the local government and surrounding community. Modelling showed that the geographic location is excellent for the southern hemisphere detector in relation to existing detectors.

The site already has utilities, access roads and some buildings and laboratories associated with the HOPF, including office and accommodations buildings and a high quality machine-shop¹⁴. The site is sufficiently large to accommodate a 4km interferometer with an orientation that complements the rest of the international array. The arms will have to be graded level for the 4km interferometer, and foundations and service roads to the end stations built. The grading must be aligned with a laser to be flat, since the local horizontal would be off by more than 1 m over the 4km length. The grading will be done with an absolute minimum of disturbance to the environment. We intend to explore the feasibility of partial submergence of beam tubes and buildings to help minimize the impact of the facility on the environment. The site preparation would also include building a large shed for the manufacture of the beam tubes, which would later be used to support site maintenance.



Figure 1.8 Aerial view of the central part of the Gingin site, showing the existing facilities.

1.5 OPERATIONAL PHASE

Following the completion of the LIGO-Australia commissioning in about 2017, continuous operation of the instrument will begin, with LIGO-Australia forming a critical component of the world-wide gravitational wave observatory.

Planning the detector runs will be done jointly with the other LIGO sites and Virgo¹⁵. Data will be collected and consolidated into a single dataset, distributed to computational centers around the world (including centres in Australia) for processing and analysis. Detector enhancements and upgrades will be researched and developed through the LIGO Scientific Collaboration¹⁶ (of which ACIGA and the LIGO Laboratory are members), and implemented in a coordinated fashion to optimize the scientific returns. (Such upgrades to the detector itself would be funded largely by the NSF.)

Based on actual experience from LIGO, and bearing in mind that this facility will operate around the clock, a dedicated team of operators, and resident scientists and engineers numbering about 25 full time people will be needed to maintain robust operation. Many of these staff members will be recruited from the local communities and trained to perform the specialized tasks necessary. In addition there will be numerous visiting scientists, and students, both from Australia and from abroad.

1.6 COLLABORATOR RESPONSIBILITIES

The LIGO-Australia project is a joint effort by Australia and the US. Each partner has well-defined responsibilities.

- The LIGO Laboratory will provide all components required to make one complete Advanced LIGO detector (including those already supplied by Australia), except for a small set of items that had been planned to be shared between the two LIGO-Hanford detectors. In addition, LIGO will provide advice and past experience with the facilities design, training for LIGO-Australia staff who will be engaged in the detector installation and commissioning, and assistance in the event problems are encountered. LIGO site civil and vacuum designs will be provided to be replicated to the extent possible except for site-specific alterations and optimizations agreed to by the LIGO Laboratory. LIGO Laboratory will review and approve the final designs for the vacuum system and the site buildings. This review is to ensure that all facilities meet the requirements to properly house and operate a sensitive Advanced LIGO detector.
- Australia is responsible for providing all the required facilities to assemble, build, house and operate the interferometer, including highly specialized, modern buildings, the entire vacuum system, all laboratory components and equipment, utilities and accommodations for computers and staff. This is a major high tech engineering and construction project and it must be built on schedule and subject to approval by LIGO Laboratory. Australia will also be responsible for the assembly and installation of the LIGO-Australia detector, its commissioning, and subsequent operations. This will require a team of long term dedicated scientists and engineers, and very close collaboration with the LIGO Laboratory for training and long term advice, as well as very close scientific collaboration.

The long-standing collaboration and respect between the LIGO Laboratory and the Australian gravitational wave community will help ensure that all aspects of the project will be well-coordinated and effectively carried out.

Other potential partners (including India or China) may collaborate under Australian leadership. Their participation will be governed by arrangements between Australia and each country.

2 ACADEMIC AND INNOVATION CASE

LIGO-Australia's primary motivation is fundamental science, with a focus that will evolve over the expected lifetime of more than a decade. Initially the emphasis is primarily in physics as it performs tests of General Relativity and its predictions, and later the focus will shift towards astronomy as detections become more frequent and gravitational wave data become a key part of multimessenger astronomy. To achieve this, LIGO-Australia will along the way pioneer new techniques in measurement science developed for gravitational wave detection and later adapted for numerous other applications. The construction project itself will build capabilities in industry that will have lasting benefits for Australian competitiveness in the world economy. Finally, the excitement of break-through science in the form of gravitational waves provides a platform for both formal and informal educational inspiration and growth in science and technology. To understand the full case for LIGO-Australia, we provide the following overview of each of these areas.

2.1 PHYSICS AND ASTRONOMY: A NEW SPECTRUM USHERS IN A NEW ERA OF EXPLORATION

Nature provides us with three distinct mechanisms, or spectra, for gathering information about the Universe, capable of traversing the great distances of space: electromagnetic waves, neutrinos and gravitational waves.

The electromagnetic spectrum was the first to be exploited, initially with the human eye, then supplanted by telescopes and photographic plates. The extension to much longer wavelengths using radio telescopes and receivers overthrew the view of a peaceful, unchanging universe by giving us a picture of highly energetic objects powered by unseen engines. In subsequent years, X-ray and gamma ray astronomy have given us new views of some of the most exotic objects in the universe, neutron stars and black holes, and the processes that form them. Today electromagnetic waves in astronomy span more than 30 orders of magnitude in frequency to provide us with an ever greater understanding of the universe around us. Nobel Prizes have been awarded repeatedly to recognize break-through astronomy, including the discovery of the cosmic microwave background¹⁷, the discovery of pulsars¹⁸, and the discovery of anisotropy in the microwave background.

The expected initial impact of gravitational wave science in the Advanced-LIGO era may be estimated by drawing a parallel with the development of neutrino astronomy, beginning in the 1960's. Pioneering work by Raymond Davis led to the first detection of neutrinos from the sun's core, giving the first direct proof of the theoretically predicted nuclear reactions powering the sun. Other detectors were constructed to study these solar neutrinos in different energy bands, and these careful experiments used the astrophysical observations of solar neutrinos to make one of the break-through discoveries in high energy physics, the spontaneous transformation of one type of neutrino into another. Finally, in 1987 one of these (Kamiokande in Japan, led by Masatoshi Koshiba) detected a burst of neutrinos from a supernova in the Large Magellanic Cloud¹⁹. This observation gave proof to the long suspected mechanism of core collapse as the mechanism driving certain classes of supernovas. Davis and Koshiba shared the Nobel Prize in 2002.

Now scientists are on the threshold of opening the

gravitational-wave window for astronomy and physics. Gravitational waves are vibrations in space and time that propagate at the speed of light. They are a direct prediction of Einstein's Equations of General Relativity, just as electromagnetic waves are a direct prediction of Maxwell's Equations, and they are as different from the static gravitational fields that surround masses as electromagnetic waves are from static electric fields. It has taken decades of both theoretical and experimental effort to develop detectors of sufficient sensitivity to detect predicted signals. A new generation of ground-based interferometric antennas will enable us to detect these waves for the first time and to begin the exploration of this new spectrum.

Matter, even in its most extreme form, is almost completely transparent to gravitational waves. This transparency means that gravitational waves can be used to probe regions of the universe that are beyond the reach of electromagnetic waves.

The most violent processes in the universe – from the big bang itself, to supernova explosions and gamma ray bursts – are hidden from electromagnetic imaging by the opacity of hot plasma. Gravitational waves, however, propagate freely, without being scattered or absorbed. They carry a faithful record of the fundamental processes at play in the most extreme physical environments in the Universe. They can reveal the rippling surfaces of new born black holes, the churning nuclear matter inside newly formed neutron stars, the gravitational collapse that powers a supernova explosion,

and the earliest moments of the Big Bang. Gravitational waves are the only means of observing some of these extreme environments.

Like electromagnetic waves, astrophysical gravitational wave signals are expected to occur over a wide range of frequencies, from 10^{-17} Hz to 10^4 Hz, and different frequency bands carry information about different sources and phenomena (Figure. 2.1). Across this huge range there are complementary efforts at detection in several frequency bands.

- At the lowest frequencies, microwave observations (e.g., from the Planck satellite) are being used to search for the signature of gravitational waves frozen into the cosmic microwave background at the time of recombination, 300,000 years after the Big Bang.
- In the nanoHertz band (~one cycle per year) precise timing of radio pulsar signals is being used to search for a statistical signature of gravitational waves from black holes, and from the collisions of super-massive black holes caused by galaxy mergers. This technique is currently being developed by three groups around the world including the Parkes Pulsar Timing Array in Australia²⁰, and is a goal for the planned SKA project²¹. At these low frequencies only a few cycles of an individual wave can be observed without waiting for decades.
- In the frequency range ~ one cycle per hour the space laser interferometer detector LISA²² is planned for the 2020s. LISA will be able to detect binary stars in our galaxy and stellar mass black holes falling into super-massive black holes.

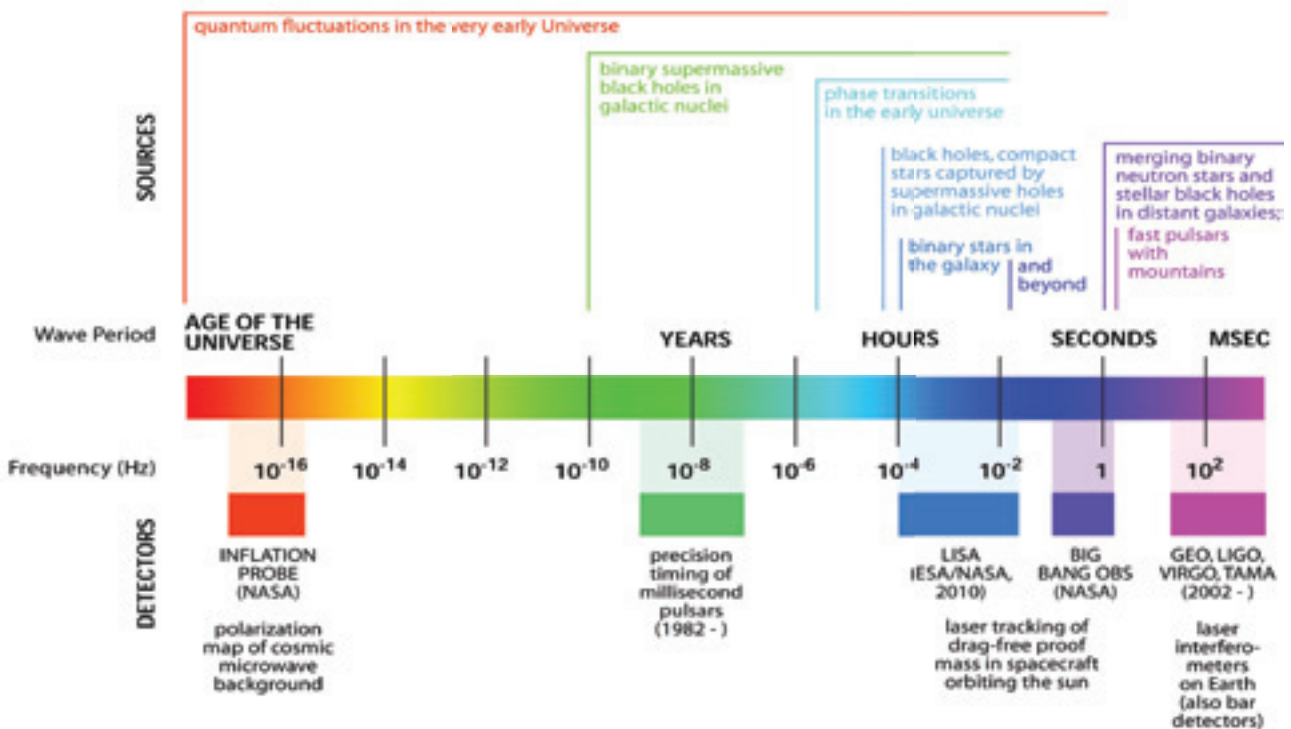

Figure 2.1 The gravitational wave spectrum spans more than 18 orders of magnitude in frequency.

Gravitational waves in these different frequency bands differ as much from each other as X-rays differ from radio waves — they are produced by different astrophysical sources and require different detection techniques.

The highest frequency band (10-10⁴ Hz) is one of the richest in its variety of sources and its potential for scientific breakthroughs, and it is the object of this proposal.

The worldwide network of advanced ground based interferometric detectors of which LIGO-Australia will be a key component is sensitive to signals in the audio frequency band, from ~10Hz to a few kHz. In this frequency band signals are expected primarily from processes involving stellar mass black holes and neutron stars, and with the possibility of seeing waves from the big bang²³. Accurate timing of the signals enables locating the source by triangulation. The advanced detectors are designed to be able to detect frequent signals from the coalescence of binary neutron stars. These are the best predicted sources that allow us to expect almost certain detection of frequent signals.

We have a huge range of predicted discoveries that we shall discuss below, but throughout we should also recognise that gravitational wave science is likely to uncover surprises, both fundamental and practical.

2.1.1 NEW PHYSICS: TESTING EINSTEIN'S THEORY

The successful detection of gravitational waves will mark the start of a major line of discovery focused on the testing of the General Theory of Relativity.

In the solar system, the predictions of General Relativity are so subtly different from Newton's theory that it takes extremely precise measurements to observe the differences between the two. Thus the solar system tests of General Relativity can be characterized as high precision measurements in the weak field limit. Even today after almost a century of experiments, the precision of testing the crucial "magnetic" component of the gravitational force is no better than about 10%. The reason for this difficulty is because gravity in the solar system is extremely weak, as we can see from the fact that gravitationally induced velocities (such as orbital speeds) are very small compared to the speed of light.

Moreover, all of the solar system tests are in the static regime—this is the equivalent of testing electromagnetism through electrostatics and magnetostatics only. Such a test, without any observations of electromagnetic waves, would be a very limited confirmation of

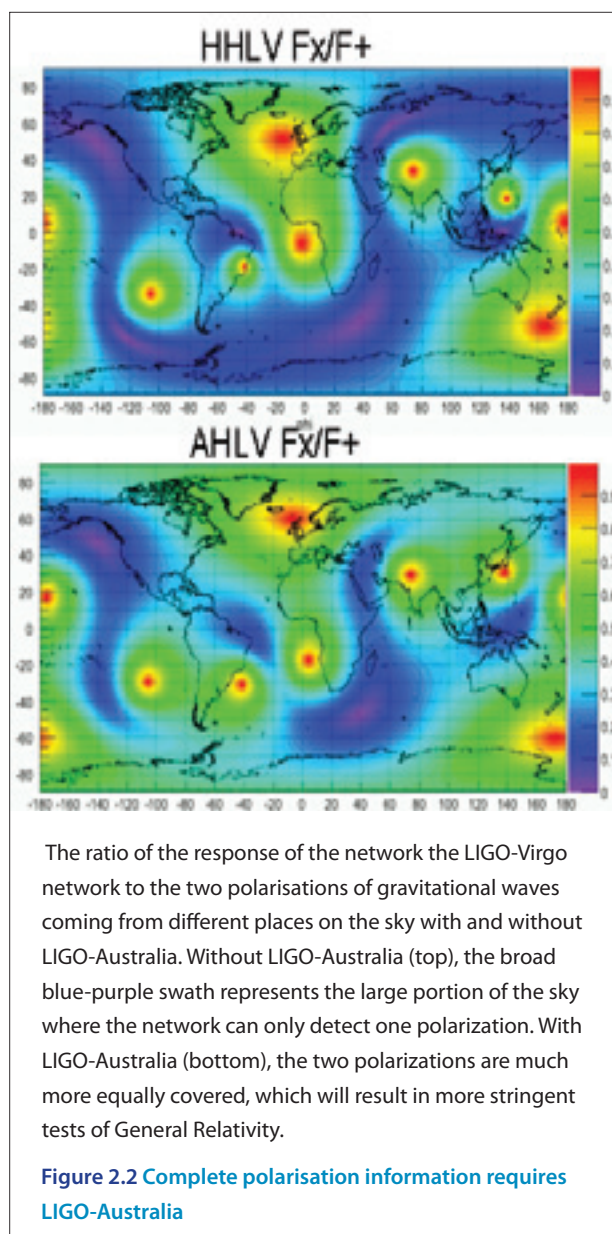

the full Maxwell Equations. The dynamic aspects of General Relativity have only been tested through the observation of the binary pulsars. By observing one remarkable system over a period of decades, Joseph Taylor and Russell Hulse were able to demonstrate that the energy loss in the system matched the prediction of Einstein's theory for the energy radiated in gravitational waves²⁴. This very important result was recognized by the Nobel Prize in 1993, and demonstrates clearly that gravitational waves exist. The *direct* detection of gravitational waves will allow a whole new suite of measurements testing Einstein's Theory.

In Einstein's theory, gravitational waves travel at the speed of light and have two polarization states. In alternative theories, other possibilities exist, for example if gravitons (carriers of the gravitational force, analogous to photons) have a non-zero rest mass due to the presence of a scalar field adding to Einstein's tensor field. However, solar system experimental tests cur-

rently lack the precision to discriminate between such alternatives. Gravitational wave detectors will provide new and decisive tests of this theory. Comparisons of the arrival time of electromagnetic waves and gravitational waves from the same object will give a precise test of the speed of travel of gravitational waves. Comparisons of the signals in detectors of different orientations can give information about the polarization states²⁵ (Figure. 2.2).

Unlike Maxwell's equations, Einstein's field equations are inherently non-linear, and thus exotic new phenomena are expected in the strong field limit, i.e., when the curvature of spacetime becomes large. Black holes are the extreme manifestation of this nonlinearity, and gravitational waves from black holes can also be used for strong field tests of General Relativity. The most promising systems for such tests are coalescing binary black holes. The Advanced LIGO detectors are expected to observe at least a few black hole coalescence events per year, and possibly many more. The signal from such a coalescence is a rising tone that sweeps upwards across the detection band over a period of minutes (a "chirp"), with modulations in intensity determined by the spin of the individual black holes. When the holes merge, the decaying ringtone of the newborn hole provides a precise description of the black hole mass and angular momentum. A major break-through in the past few years has come from applying modern supercomputers to solve Einstein's equations numerically to produce predictions for the gravitational waveforms from such systems²⁶. Comparing observed and predicted waveforms may give a precise confirmation that general relativity is correct, but could show deviations if new physics comes into play.

There are grounds for suspecting that we might discover new physics when we observe black hole coalescences. The well known incompatibility of Quantum Mechanics and General Relativity leads us to expect that General Relativity will fail in strong fields, hopefully giving clues to a new theory that could unify quantum mechanics with gravity.

Gravitational waves from black hole perturbations explore a regime of gravity more than one million times stronger than hitherto accessible, so new physics is a real possibility.

2.1.2 NEW PHYSICS: BLACK HOLE PHENOMENA

General Relativity predicts numerous properties of black holes which were "discovered" theoretically in the 1960s to 1980s by Roger Penrose, Stephen Hawking, Kip Thorne, S. Chandrasekhar, J.A. Wheeler and others.

These "discoveries" are predictions and consequences of the General Theory of Relativity.

Hawking's surface area theorem states that in all processes the black hole horizon area always increases. Wheeler coined the No Hair Theorem to emphasise that black holes have only three observational properties, mass, charge and angular momentum, with a structure defined by an exact solution of the Einstein equation discovered by New Zealand mathematician Roy Kerr. All knowledge of what they are made from is lost to the universe, and at their surfaces time comes to an end. Following from this is the famous black hole quantum information paradox that addresses the question of what happens to the information when matter falls into a black hole. Chandrasekhar showed that black holes should have a spectrum of vibrational modes that depend uniquely on their mass and spin. Penrose introduced the Cosmic Censorship Conjecture which says that the singularity inside a black hole is always hidden from the outside universe.

All of the above fundamental propositions, predictions and conjectures are amenable to observational testing by observing the formation and coalescence of black holes.

- The ringing of black hole normal modes will test General Relativity at the strongest fields.
- Estimates of the initial and final black hole masses allows observational testing of the black hole surface area theorem.
- Observation of systems with large mass ratios such as those where a smaller black hole coalesces with a heavier black hole can be used to test the no hair theorem.
- A smooth transition from the chirp of the inspiral phase to the ringing normal mode of the final black hole will confirm classical general relativity, while distortion could reveal new physics or violation of cosmic censorship.

Whether or not we observe violations of the above predictions, we will be able to test the theory to a precision determined by the precision of the parameter estimation. LIGO-Australia allows significant improvement of parameter estimation because it improves the polarization sampling of signal waveforms (see Figure 2.2) and also because it enables noise rejection through the improved directional sensitivity.

2.1.3 NEW PHYSICS: UNDERSTANDING NUCLEAR MATTER

The theory of quantum chromo-dynamics (QCD) unifies the strong nuclear force (and its associated quarks and colour-charge carriers called gluons) with the weak

Australia is emerging as a priority site for a number of next-generation, all-sky instruments which will further change the way we observe the universe around us. Construction on the Australian SKA Pathfinder (ASKAP), a technology testbed for the SKA, has already commenced in the remote WA desert. This location is one of the two sites under consideration for the SKA, to be operational from 2020 onwards. These instruments operate in dramatically different ways from most contemporary radio telescopes. They consist of an array of relatively standard antennas coupled by sophisticated computer hardware and software systems that enable them to look simultaneously in many directions.

At the same time, robotic optical instruments like SkyMapper and the Zadko telescopes in Australia (see also sec. 3.3.3 New Tools for Multimessenger Astronomy) and many others in the northern hemisphere are able to respond rapidly to triggers from gravitational wave detectors and to provide transient data to guide gravitational wave data searches. NASA's *Swift*³⁰ and ESA's *INTEGRAL*³¹ satellites (and others) provide near-all-sky monitoring in X-rays and gamma rays. For these followup measurements, localization of event positions on the sky is critical, and LIGO-Australia will offer sub-

stantial improvements in the precision with which the origin of gravitational wave events can be determined (Figure. 2.4).

The above approach dovetails with the burgeoning field of particle astrophysics. Energetic, strongly gravitating objects like black holes and neutron stars are some of nature's most potent particle accelerators. The neutrino burst from a supernova carries unique information about the thermonuclear reactions and particle physics processes that occur inside the core of a collapsing star. Huge detectors like IceCube³², where a cubic km of the Antarctic ice cap is instrumented to detect neutrinos, will be on line at the same time as LIGO-Australia. Simultaneous gravitational wave and neutrino observations of a nearby supernova will provide new insights into the formation of the chemical elements, the birth processes (and resulting spins and magnetization) of neutron stars and black holes, and enable new tests of the Standard Model of the fundamental forces³³.

In the 2020s we can expect that we will be monitoring the sky simultaneously across the electromagnetic spectrum, and with neutrino and gravitational wave detectors.

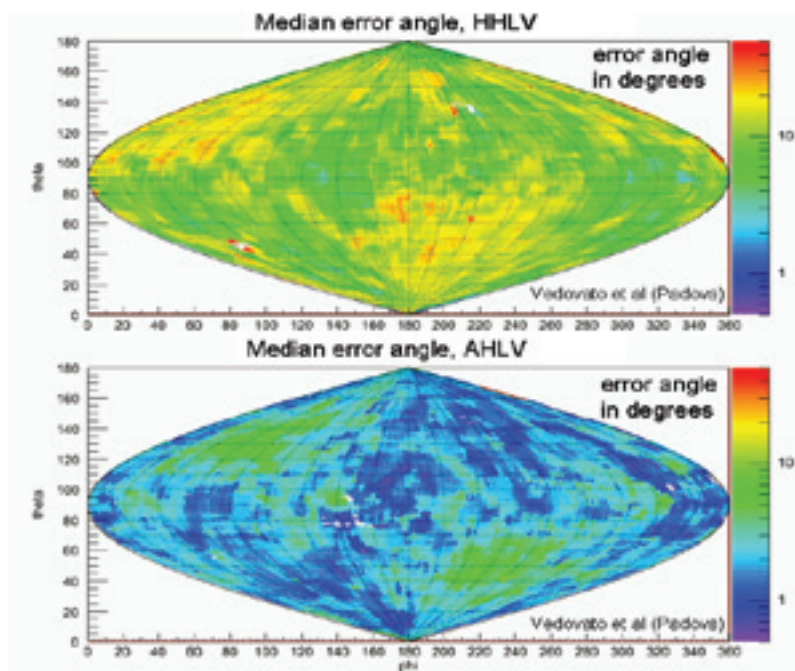

With LIGO-Australia (lower map), source localisation (equivalent to triangulation) can be dramatically improved over the network without it (upper map) by turning the existing almost planar array into a tetrahedral configuration. LIGO-Australia results in a five to ten-fold improvement in positional accuracy. Source uncertainty regions can be as small as one square degree, with uncertainty contours that are roughly circular. Once LIGO-Australia is in place the error ellipses are well matched to the field of X-ray, optical, and radio telescopes, like the Square Kilometre Array (SKA). This will revolutionize the speed and effectiveness with which electromagnetic telescopes can identify and study sources.

Figure 2.4 LIGO-Australia enables us to pinpoint gravitational wave sources in the sky to enable electromagnetic telescopes to work with gravitational wave detectors to maximise the science outcomes.

LIGO-Australia and the SKA project stand to give Australia a prominent role in this world-wide enterprise as we watch and listen to extraordinary events occurring throughout a vast volume of the visible universe.

The future of astronomy will increasingly see the emergence of multi-band, wide-field capability which, when coupled with the worldwide gravitational interferometer network, will give us vast new quantities of information with which to understand the universe around us. It would be a remarkable testament to Australia's research and technology strengths if two of the leading instruments providing this capability are either fully or partially located in Australia.

2.1.5 NEW ASTROPHYSICS: NEUTRON STAR COALESCENCE EVENTS

Coalescing binary neutron stars hold a particular importance for Advanced LIGO because these are the best understood sources in terms of knowing both the strength of their gravitational waves and the frequency with which they occur in the universe³⁴.

A number of progenitors for such events (including the famous Hulse-Taylor Binary Pulsar) are known in the Milky Way, and observational data can be used

to estimate their event rate. The initial LIGO detectors benchmarked their performance by the detectability range for neutron star coalescence, achieving a range of about 50 million light years. Advanced detectors are designed to increase this range 10-fold increasing the volume of space being monitored and hence the expected event rate by a factor of 1000.

The neutron star coalescence signal can be well modelled in General Relativity up to the final few cycles when tidal distortion becomes large. Finally the stars should merge to create a black hole. The characteristic chirp signal which lasts for more than a minute is very distinctive and can be extracted efficiently from noisy data by matched filtering. Best estimates predict about 50 detectable coalescence events per year. These events are likely to be strong electromagnetic sources and prompt follow-up with X-ray, optical and radio telescopes will be essential to fully understand the sources.

Binary neutron star coalescence is thought to be the cause of short, hard gamma ray bursts (GRBs)³⁵. Observation of a coincidence between a short hard GRB and a gravitational wave signal would be proof of this connection, but would only begin to exploit the power of gravitational wave observations of such systems. Gravitational waves can be used to determine the inclination of the binary system (orientation relative to the line of sight) and comparisons of the gamma ray signals as a

For neutron-star and black-hole coalescences, where the burst signal can be modelled theoretically, LIGO-Australia boosts the accuracy with which system parameters can be determined from the data. With the LIGO-Virgo network alone, unknowns such as the source distance and inclination cannot be cleanly separated, which contributes to uncertainties in component mass, angular momentum and distance determination.

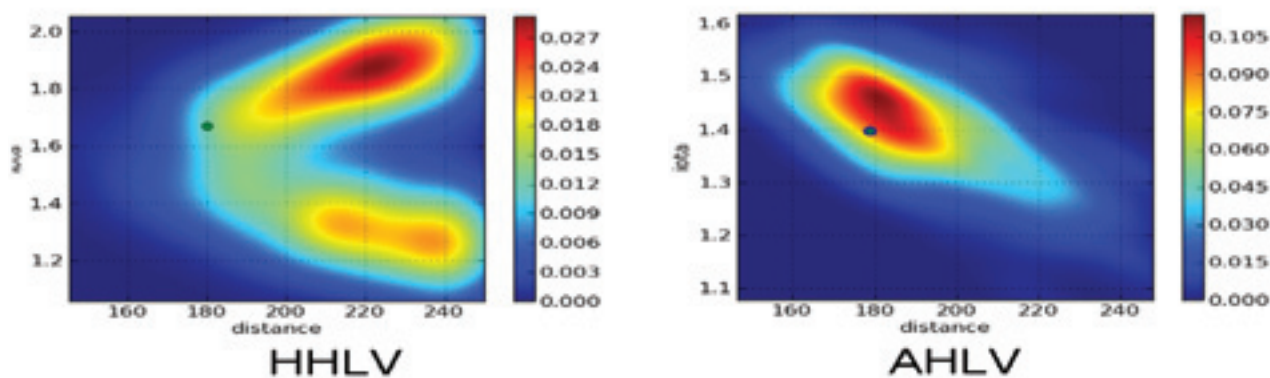

This simulation of neutron star coalescence shows the improvement in determining the source distance and inclination by including LIGO-Australia (right) over the LIGO-Virgo network (left, note that the two figures have different scales).

The contour maps show two dimensional probability densities for the model parameters of a binary neutron star system's luminosity distance and orbital inclination angle relative to the line of site in the two networks. The green dot shows the true values of the input. The solution using the network without LIGO-Australia is bimodal, but the degeneracy is broken by LIGO-Australia.

Figure 2.5 LIGO-Australia dramatically improves source parameter estimation

function of inclination angle will determine the beaming, a crucial quantity for understanding the energetics. Gravitational waves can also be used to determine the masses of the initial neutron stars, also an important parameter for understanding the electromagnetic emission mechanism (Figure 2.5). Finally, the gravitational waves can be used to determine whether the final object formed is a black hole or a neutron star, again constraining the physics of the merger.

Observing a number of coalescence events and correlating them with electromagnetic signatures will be crucial to these studies. The improvement in localisation capability with LIGO-Australia offers an overwhelming advantage and will shorten the time needed to collect sufficient statistics by a factor of 5 or more³⁶.

2.1.6 NEW ASTROPHYSICS: COSMOLOGY WITH GRAVITATIONAL WAVES

Modern cosmology predicts that in its first fractions of a second the Universe underwent phase transitions, where space and time underwent sudden changes in structure. Gravitational waves offer the few means of observing this period³⁷. Fundamental theories predict that the phase transitions are accompanied by gravitational wave emission, with characteristic spectral signatures linked to the type of phase transition. Detection of these primordial signals by LIGO-Australia is by no means guaranteed, but if such waves are seen, they would represent a true break-through discovery in cosmology, providing a direct observational tool for understanding the process of the big bang³⁸.

Gravitational waves also provide a powerful tool for probing the distributions of matter and energy in the universe. Modern astronomical observations imply that dark energy contributes about 73% of the total mass-energy of the universe, dark matter contributes about 23%, and normal matter contributes just 4%. One effective way to probe the nature and distribution of these dark components is to make precise measurements of the distances and the recession velocities (redshifts) of distant galaxies. Currently supernovae are the only “standard candles” that allow such measurements. However gravitational wave signals from coalescing neutron stars or black holes provide an alternative and quite independent tool. This is possible because of the remarkable fact that gravitational wave signals from binary coalescence actually directly encode the parameters of the source³⁹. By measuring the gravitational waveform, one can determine the intrinsic parameters of the system— the masses and spins of the stars and the orientation to the line of sight. With this information we can accurately deduce the distance of the system.

A key feature of coalescing binary black holes or neutron stars is that they eliminate the need to build a cosmic “distance ladder” for estimating cosmological distances, with its potential for systematic errors such as dust obscuration.

Two requirements must be met to be able to use gravitational wave observations for measuring the distance-redshift relationship. First, the measurement requires complete polarization coverage, to be able to extract the inclination of the binary orbit. Second, it is essential to be able to identify the host galaxy in which a coalescence occurs, so as to measure its redshift. This is difficult especially in the case of binary black hole coalescences (which are likely to be free of any electromagnetic signature). Multiple detectors spanning the globe with complementary orientations are essential to both of these measurements. Adding LIGO-Australia to the worldwide array is crucial for the improved angular resolution that makes host galaxy identification possible⁴⁰, and its orientation has been selected to help optimize the polarization coverage for this and other observations. (Figures 2.2 and 2.4)

2.1.7 NEW ASTRONOMY: LISTENING TO THE MOST ENERGETIC EVENTS IN THE UNIVERSE

Modern astronomy has revealed a diverse and exotic Universe, full of explosive, ultra-energetic phenomena, which remain enigmatic decades after their initial discovery. All of these events involve strong gravitational fields and are potential sources of gravitational waves.

Examples include:

Supernovae: These cosmic explosions arise from the sudden gravitational collapse of a star⁴¹, followed by a dramatic explosion, during which many of the chemical elements that make up our human bodies and our planet are synthesized; the mechanism of the explosion is not understood.

Gamma-ray bursts: these intense bursts of radiation last only a few seconds, yet emit more energy than a star in its entire life time; the mechanism is not understood but is thought to involve the birth of a black hole⁴².

Magnetar bursts: these ultra-magnetized neutron stars thousands of light years away sporadically emit intense bursts of radiation, so powerful that they can disrupt radio communications and power transmission on Earth⁴³.

The visible display of a supernova represents the outer layers of the star being ejected by the central core collapse and it is quite easily studied via electromagnetic waves. However, these electromagnetic observations carry little information about the actual core collapse and the mechanism that turns this collapse into an outgoing explosion.

Gravitational waves from the core collapse will carry direct clues to the motions within the core that drive the supernova. Short gamma-ray bursts may arise from coalescing neutron stars, as discussed above. Long gamma ray bursts have been connected with core collapse supernovas, and may represent the most energetic of a range of supernovae progenitors. The information provided by gravitational waves could be important to their understanding.

The gravitational waves from Magnetars are intrinsically much weaker than those from binary black holes or neutron stars, but the comparative closeness of these galactic sources makes their gravitational wave emissions potentially observable.

Thus, the gravitational window on these phenomena will help astronomers resolve puzzles that have persisted for decades. The angular resolution and the polarisation data provided by LIGO-Australia will be crucial for these observations.

2.1.8 NEW SCIENCE: THE UNEXPECTED

Despite 40 years of enormous effort to predict and model sources of gravitational waves, it is most unlikely that human imagination has covered all the possibilities. If the history of electromagnetic or neutrino astronomy is an example, gravitational-wave astronomy should encounter phenomena and sources never imagined. Thus it is likely that the most exciting discovery made in the new gravitational window will be unlike any of our predictions. Understanding new sources will no doubt require all of our available tools. The polarisation coverage and angular resolution provided by LIGO-Australia will be crucial in this task.

2.2 TECHNOLOGY INNOVATION: BREAKING NEW GROUND IN PRECISION SENSING

The current generation of gravitational wave interferometers has produced the most precise physical measurements and the most sensitive optical interference measurements ever made, as can be seen in the achieved sensitivity in the first generation LIGO detectors shown in Figure 1.4. The initial LIGO design sensitivity corresponds to measuring a minimum change in length of 10^{-18} m, a dimension equal to billionth of a single atom, or one ten thousandth of a single proton. The Advanced LIGO detectors, including LIGO-Australia, will be a factor of 10 more sensitive⁴⁴.

This superb sensitivity has necessitated developments and innovations in every part of the instrument and the measurement process. Each element of the interferometer influences the sensitivity, and numerous developments and improvements were required first for initial LIGO and then for Advanced LIGO. A sensitivity budget, showing the large number of noise sources that must be considered is shown in Figure. 1.4, including those by the mirrors, the optical coatings, the laser, the isolation system, the vacuum system and the interferometer configuration.

LIGO-Australia will continue the process of technology innovation to improve the sensitivity even further. This innovation is a result of an international effort centred around LIGO, including a significant and ongoing contribution from the ACIGA universities and the CSIRO in Australia.

The presence of an Advanced LIGO detector in Australia will spur interest from others interested in stretching the limits of technology, and ready access to a platform to test new ideas and technologies will result in even greater future innovation than has occurred in the past.

2.2.1 LASERS AND OPTICS

Gravitational wave detectors require the purest laser light ever created, and the field has pioneered new laser technologies that represent the state of the art. Nonetheless, very significant innovation and developments in laser technology are continuing, with the goal of further improvements in low phase noise, excellent beam quality and high, single frequency power. The development from LIGO to Advanced LIGO primarily required the development of lasers capable of emitting 20 times more power, while maintaining the spatial mode and

frequency stability. ACIGA played a significant role in that development.

Past laser development has concentrated on Nd:YAG, while future work will shift to emerging and potentially superior technologies both in terms of hosts, wavelength and architectures (e.g., Er:YAG and fibre lasers). The laser power currently limits the sensitivity of LIGO-Australia only at high frequencies, and it is expected that the phase noise achieved, once locked to the interferometer, will be better than required, and will not be a limiting factor. Nonetheless, continued innovation is required to optimize and improve the performance as we aim for future upgrades.

The laser developments for gravitational wave detection have an enormous range of applications from precision metrology to medicine to micromachining. The future demands of gravitational wave technology will ensure that Australia remains in the forefront of this field. Frequency stable lasers, for example, are needed for coherent laser radar and strain sensors for the prediction of earth quakes, and other precision metrology.

Gravitational wave detectors require mirrors with surface accuracy more than 100 times better than telescope mirrors, and coatings with ultrahigh reflectivity. The CSIRO Australian Centre for Precision Optics (ACPO) has the expertise to create such optics and has been a major supplier to the LIGO project for more than 15 years. The mirror substrates and the optical coatings for LIGO-Australia have gone through a very extensive development and selection process to minimize the thermal noise and the thermal deformation of the optics.

Ironically, ACPO's world leading position in precision fabrication of optics and optical coatings has been far more appreciated overseas than in Australia. LIGO-Australia will enhance the ability of ACPO to show off its technology and expand its business, including within Australia. Wider appreciation of this unique capability should spur other applications for Australian industry. Continuing improvements to LIGO-Australia will ensure that ACPO's expertise continues to develop, helping Australia maintain this state of the art capability.

The high optical power in the LIGO-Australia detector causes heating and distortions that would prevent achieving the required sensitivity. To counter these distortions, a very intricate compensation scheme to detect and correct the thermal deformations due to the high optical power was introduced. ACIGA has collaborated with LIGO over the years first in observing and quantifying this deformation and then in the investigation of compensation schemes. An example of innovation is the development of a Hartmann wave-

front sensor by ACIGA⁴⁵, which is capable of measuring wave-front distortions as small as 1/20,000 of an optical wavelength, well in excess of the stringent requirement of about 1/1,000 of a wave required for LIGO. This and other innovations are now also being adapted for use in other applications.

2.2.2 VIBRATION ISOLATION AND SUSPENSION

Gravitational wave detectors require vibration isolation performance that vastly exceeds that of conventional systems⁴⁶. Already gravitational wave technology has been used to create vibration isolators for airborne magnetic mineral exploration devices 100 times better than previously available devices. UWA researchers are working with Fugro Airborne Surveys to introduce high performance vibration isolation for airborne electromagnetic survey instruments, which are expected to allow the discovery of minerals at double the depth currently available. LIGO-Australia will greatly enhance our capacity for such industry spin-offs.

The advanced seismic isolation scheme adopted for LIGO-Australia combines two systems: an active system based on precision sensing and feedback, and a passive system developed by our LIGO collaborators in the UK. The active isolation stages are applicable to precision manufacturing (micromachining, semiconductor fabrication using optical masks, etc). The UK system uses innovative fabrication techniques, which will have to be replicated in Australia with specially chosen materials for the suspension fibres and the springs. Both of these systems can be adapted to other applications.

2.2.3 SQUEEZING AND QUANTUM MECHANICAL LIMITS

The extreme sensitivity of the Advanced LIGO detectors will move them to a level where they must confront the quantum mechanical limits to measurement, as defined by the Heisenberg Uncertainty Principle. Remarkably, these detectors will be limited in their sensitivity by the quantum-limited radiation pressure fluctuations⁴⁷ in the laser beams incident on their 40 kilogram mirrors. The sensing schemes which permit the Advanced LIGO detectors (including LIGO-Australia) to reach these levels include significant contributions developed and delivered by ACIGA.

Future improvements to the Advanced LIGO detectors (including LIGO-Australia) will require further innovations such as squeezing to improve the sensitivity by lowering the phase noise achievable^{48,49}. Such light has smaller statistical fluctuations in intensity or phase than normal light, and it enables a light beam to achieve the

sensitivity of a much brighter one when it is used for precision measurements. ACIGA includes world leading expertise in squeezing, and this technique is expected to be included during later up-grades.

Other possibilities for improving the sensitivity of LIGO-Australia include “optical bars” and optical springs. Optical bars use forces created by intense laser light radiation pressure to create stable rods which are stiffer than solid diamond⁵⁰. Optical springs use optical configurations to create forces on a mirror that vary with spatial position, just like a mechanical spring⁵¹. However, unlike mechanical springs, these systems can have either a positive or negative spring constant, either positive or negative damping, and can be combined to create complex systems with properties that are impossible with mechanical springs.

These techniques are interesting in their own right, as they force us to confront how our macroscopic world transitions into the regime of quantum mechanics. The field of macroscopic quantum mechanics, where scientists attempt to observe the effects of the Heisenberg Uncertainty Principle on macroscopic objects or attempt to put resonant mechanical systems into their quantum ground state, grew out of the considerations of gravitational wave detectors, and the interactions are still strong.

These techniques also have potential application in other areas. Squeezed light could allow biological or physical measurements with 10 times less light than is currently required. Applications for optical bars are just emerging, with potential application in the readout of sensitive gravity gradiometers for mineral exploration.

2.2.4 COMPUTATIONAL INNOVATION

The extraction of a gravitational wave signal from a particular direction in space, from an array of gravitational wave detectors is a significant computational challenge. In Advanced LIGO detectors the challenge is increased because of the increased instrument bandwidth. Chirping signals from coalescing binary systems remain within the instrument bandwidth for much longer, greatly increasing the data analysis task. Substantial supercomputer resources are available within the LIGO Scientific Collaboration as well as in Australia to carry out such searches. The search for unknown pulsar signals requires maximal computational power, for which some innovative solutions have been adopted. For this type of signal, LIGO uses Einstein@Home*, a system which utilizes CPU time do-

nated by members of the public. As of November 2010, over 280,000 volunteers in 192 countries have participated in the project, and about 58,000 active users contribute about 370 teraFLOPS of computational power, which ranks Einstein@Home among the top 20 of the TOP500 list of supercomputers.

Members of ACIGA have been very active in developing new computational technology in preparation for the era of Advanced LIGO detectors. They pioneered the use of Graphics Processors for accelerating gravitational wave data analysis⁵² and developed new signal processing algorithms, which enable real time detection and localization⁵³. This is very important for multi-messenger astronomy where electromagnetic telescopes must obtain very rapid alerts from the gravitational wave network. The ACIGA computational group works closely with SKA project scientists who face similar needs for enhanced computational methods.

There are enormous opportunities for further developments, from Cloud computing to new hardware and software tools that will ensure that LIGO-Australia remains in the forefront of computational innovation.

2.2.5 LARGE SCALE HIGH VACUUM SYSTEMS

The LIGO-Australia vacuum system will be the largest ultra-high vacuum system in the Southern Hemisphere, and will provide Australian industry with both challenge and experience to expand their capabilities.

The required vacuum level (10^{-9} torr) requires leak free welding and special cleaning techniques. A major innovation goal is the development in Australian industry of a world-leading capability in major vacuum system manufacture, a capability that will provide spin-offs in improvements in the production of large tanks for food and wine, as well as new science and technology.

Current plans are to use innovative on-site fabrication of the stainless steel pipe using a portable pipe mill to enable low cost construction. This experience will give the manufacturer a competitive edge for other similar applications worldwide. Innovations include on-site production to reduce transport costs and computerised multi-sensing quality control. Both costs and energy use will be minimised through these innovations, which will give Australian industry opportunity for substantial overseas contracts.

* <http://einstein.phys.uwm.edu>

2.3 CREATING EDUCATIONAL OPPORTUNITIES WITH LIGO-AUSTRALIA

LIGO and ACIGA both have strong traditions in education and outreach, and LIGO-Australia will provide a platform to increase these efforts and benefit from the synergies.

LIGO-Australia will support a very strong education effort at primary, secondary, tertiary and postgraduate and public outreach levels. Outreach is mandated by the WA Government in return for its provision of land for gravitational wave astronomy.

2.3.1 CURRENT ACTIVITIES AT LIGO-AUSTRALIA SITE

The UWA team already operates a major educational centre on the proposed site for LIGO-Australia. The Eureka Prize winning Gravity Discovery Centre* (GDC) offers special education programmes for primary and secondary students as well as the general public. It has

lecture venues, public telescopes, the Leaning Tower of Gingin for school experiments, large scale exhibits and a Cosmology Gallery developed as an educational resource that combines multicultural creation stories with scientific cosmology, intended especially to appeal to indigenous students and students from multicultural backgrounds.

The GDC facilities are also used for tertiary teaching purposes, supporting astronomy and experimental general relativity courses from 2nd year to postgraduate courses. It has been proposed that a new broadening undergraduate science course be based around facilities at the Gravity Discovery Centre. These programs will be made available nationally following the model of the successful joint honours teaching initiative between UWA and the ANU.



Figure 2.6 The GDC supports PhD research on educational enrichment, with projects specifically designed to assess the education benefits of the enrichment programmes for different cohorts of school students.

* www.gravitycentre.com.au

2.3.2 FACILITATING POSTGRADUATE TRAINING AND MOBILITY

The Australian consortium has an excellent record of postgraduate training with 50 PhD completions in the last 5 years and about 40 current PhD students.

Students work on areas from high power lasers to quantum measurement, grid computing to advanced signal processing algorithm development, gamma ray bursts to theoretical models of nuclear matter, and engineering new instruments for exploration technology. The international nature of gravitational wave research also gives both postgraduate students and undergraduate students opportunities to obtain international experience. Almost every postgraduate student in ACIGA has the opportunity to work with collaborators at Caltech and MIT, or to work in the LIGO observatories. On graduation students obtain top postdoctoral positions at top international locations such as Caltech, MIT, ENS Paris, Oxford, or else they obtain employment in industry. Most plan to return to Australia after international experience and this will be enhanced by the opportunities of LIGO-Australia.

Compared with many other countries, Australian students are far more likely to begin university at their local university, continue there for their honours and PhD studies, and finally do postdoctoral research without ever gaining the exposure to new ideas and establishing professional contacts across the nation. By uniting research groups from multiple Go8 universities, LIGO-Australia will help to increase the mobility of university students within Australia. Joint honours courses (such as UWA's course in Experimental General Relativity) plus summer schools and vacation scholarships will make both staff and students aware of the opportunities elsewhere in the collaboration. With a common sense of purpose there will be incentives to match students to their optimum research choice rather than encouraging students to stay within their home institution.

2.3.3 NEW TOOLS FOR MULTIMESSENGER ASTRONOMY

By giving the global array of detectors angular resolution matched to electromagnetic telescopes the LIGO-Australia project opens up the new area of multimessenger astronomy in which combined observations with radio, optical, x-ray, gamma ray and neutrino telescopes provide far more information than any can provide individually. LIGO-Australia will support a strong education program to provide training for others outside the field to obtain sufficient understanding of gravitational

wave detection to be able to use these new tools. It will also support numerous PhD research projects that span the spectra from neutrinos to gravitational waves to electromagnetic astronomy. Such efforts are already in preparation but the skills and techniques are only now being developed. For example the LIGO-Australia site supports the Zadko Telescope, a 1m fast response robotic telescope which has already been used for follow up observations from gravitational wave detector triggers, as well as for PhD research in transient astronomy. The ANU group has strong links to Skymapper⁵⁴, an even more powerful telescope now being commissioned by Mt Stromlo Observatory that has already signed an MOU with LIGO for multimessenger astronomy. Members of the LIGO Australia team are part of the ASKAP transient search project and such work will extend to the SKA.



Figure 2.7 The Zadko 1m telescope is co-located on the site for LIGO-Australia and was used during 2010 in the first trials for rapid optical observations of possible gravitational wave triggers from the LIGO-Virgo network.

Once the Advanced LIGO observatories are in operation multimessenger astronomy will become an extremely powerful tool. It will support numerous Masters and PhD projects, and will also motivate an expanded nationwide and international program of education enrichment⁵⁵. Already the Zadko telescope is used in joint school programmes between WA and both Provence (France) and Glasgow. It allows school students to undertake enrichment projects doing real research, including the follow up of gamma ray bursts and supernovae that are likely gravitational wave sources.

2.3.4 BRINGING GENERAL RELATIVITY INTO THE NATIONAL CURRICULUM

General relativity is already moving from the advanced tertiary level into the high school curriculum. UWA has a PhD student who is testing the ability of primary school children to conceptualise the geometry of curved space. ANU has developed powerful visualisation tools to support relativity education. The University of Melbourne is already hosting cross-institutional educational materials prepared around the LIGO-Australia informational video. The Gravity Discovery Centre has developed education modules on gravitation, time, and quantum weirdness. Strategic partnerships with the Victorian Department of Education and individual high schools (including exam committees and teacher development programs) have introduced relativity into the Victorian secondary curriculum.

LIGO-Australia will allow all these education products already developed to be offered nationally. It will facilitate national travelling exhibitions of outreach materials and through strategic partnerships with curriculum councils will work towards introduction of Einsteinian physics into secondary education curricula across Australia.

Specific programs will include:

- Sabbaticals for high-school teachers to collaborate with LIGO researchers
- Email help desk for teachers with relativity questions
- Learning materials for the national curriculum, including thought experiments and real-world applications such as GPS navigation
- Visualisation tools for making Einstein's theory come alive in the classroom
- Public and high-school lectures in regional centres, as part of a broader effort to improve entry pathways to university for regional students
- Incursions of PhD students into high-schools

2.3.5 INTERNATIONAL EDUCATION AND PUBLIC OUTREACH

Another very strong component of LIGO-Australia will be its link to the international education and public outreach working group of the LIGO Scientific Collaboration. This working group links gravitational researchers interested in education across the globe, facilitating the creation and dissemination of education products internationally. ACIGA members are already very active in this working group as reported in the LIGO Scientific Collaboration's EPO White Paper 2010.

LIGO-Australia will enable education links and benefits that will accrue from the strong integration between LIGO-Australia and the other LIGO facilities. This will include special exhibitions for science centres and also provision of public speakers. The Australian consortium has an excellent record of public lectures on topics in gravitational wave science. Public fascination with black holes usually ensures very large audiences. Nationally, there have been an average of 10 or more public lectures per annum, often drawing capacity crowds in large University auditoriums. Speakers have included Kip Thorne, Roger Penrose and Roy Kerr. This program will expand with LIGO-Australia, especially because of the exciting discoveries we expect.

3 RELEVANCE TO AUSTRALIAN NATIONAL PRIORITIES

The Australian Government has defined four broad National Research Priorities complemented by seven National Innovation Priorities. The importance of ‘Big Science’ (eg, astronomy, particle physics) in driving research and innovation and the need for access to such major science facilities has been recognized in the NCRIS roadmap. LIGO-Australia will provide physicists with access to a major onshore physics facility whilst continuing Australia’s outstanding record of being in the vanguard of, and hence reaping the rewards from, new astronomical fields.

In the area of education, Australia is moving to a national curriculum framework. Within this framework, The Australian School Science Education National Action Plan 2008-2012 (D Goodrum and L J Rennie 2007) has recommended Priority Actions for science education. LIGO-Australia will provide a means to respond to these recommendations.

Australia also places high national priority on its environment, on preserving the unique diversity, while using resources in a sustainable fashion. LIGO-Australia is conceived with those national priorities in mind.

3.1 NATIONAL RESEARCH PRIORITIES

Of the four National Research priorities, gravitational wave research falls primarily and squarely within the second national research priority area “Frontier Technologies for Building and Transforming Australian Industries.” LIGO-Australia also has significant crossover impact on two other national research priority areas, “An Environmentally Sustainable Australia” and “Safeguarding Australia.”

3.1.1 FRONTIER TECHNOLOGIES FOR BUILDING AND TRANSFORMING AUSTRALIAN INDUSTRIES

Within the Frontier Technology priority area, LIGO-Australia addresses four of the five subtopics in this priority area.

1. Breakthrough science

The detection of gravitational waves, a nearly century-old prediction from Einstein’s famous theory, is the very epitome of breakthrough science.

However, this will be just the first breakthrough of many. The discoveries will have a transformational impact across a broad range of topics in fundamental physics, cosmology and astrophysics, and measurement science.

Breakthroughs in fundamental physics and relativity could include:

- Detection and localisation of gravitational waves from various sources
- First direct observation and characterisation of black holes
- First observation of gravitational waves from the primordial universe (big bang)

Gravitational wave science offers other breakthroughs in cosmology and astrophysics:

- Independent measurement of the cosmic distance scale
- Determining the abundance and mass distributions of stellar-mass black holes
- Understanding of the central engine behind gamma-ray bursts
- Understanding the properties of nuclear density fluid using observations of neutron stars
- Understanding the intense flashes of X- and gamma-ray radiation in magnetars

The extreme challenge of gravitational wave detection will yield many breakthroughs in measurement technology:

- Probing the quantum limits of measurement in macroscopic systems
- Understanding the ways quantum measurements transition into the classical regime
- New methods for analyzing general opto-mechanical systems in the quantum regime
- Behaviour of macroscopic systems as they approach the quantum ground state

Thus, even as these giant detectors set off a revolution in gravitational wave astronomy, these exquisitely sensitive devices may also revolutionize our understanding of quantum mechanics.

2. Frontier technologies

Gravitational wave detection is an “instrument technology intensive” field, pushing the frontiers simultaneously in a number of fields, in particular lasers and photonics, which has been a traditional strength in Australia.

In photon sciences, the demands of gravitational wave detectors including LIGO-Australia and future upgrades will provide continuing impetus for new technologies with broad applications both in research and industry.

Lasers developed for the initial LIGO detectors are now used in many research laboratories and are preparing the way for space laser communication. The drive for development of higher and higher power single frequency continuous wave lasers, including fibre lasers at both 1.06 microns and 1.55 microns (in the communication band) offers new opportunities in a huge range of industrial applications.

The extreme requirements on stability and sensitivity in gravitational wave detectors translate into new sensing techniques for other fields where less demanding applications still represent enormous improvements over the state of the art. Spinoffs will continue to impact on diverse areas such as remote sensing, laser radar and sodium guide stars for optical astronomy. Techniques for locking lasers to optical cavities were developed for gravitational wave detectors and are now used for frequency standards, precision spectroscopy and optical communication.

Ultra pure optical substrates, ultra low absorption optical coatings and ultralow acoustic loss optics were all developed for gravitational wave detectors and now provide a set of resources which can be exploited for a variety of precision photonic applications.

The new gravitational wave detectors open up new horizons of measurement where sensitivity can break the standard quantum limit noise barrier, using squeezed light sources (pioneered at ANU) and optical springs (pioneered by LIGO). These technologies will have a profound impact on fundamental measurement science through improvements to opto-mechanical sensors and transducers.

This cross-fertilization will continue, especially in sophisticated optical measurement schemes, laser sources and material investigations, as scientists search for ways to improve LIGO-Australia beyond its initial level.

3. Smart information use

Gravitational wave detection represents one of the greatest computing challenges currently being tackled by humankind. The need to locate miniscule signals buried deep in non-stationary, non-Gaussian noise from specific but unknown locations in the sky is spawning key advances in distributed computing and digital signal processing, with wide applicability in industrial sectors like cloud computing and remote sensing.

Distributed computing: A classic example of the pioneering influence of gravitational wave science in distributed computing is the hugely successful Einstein@Home project, adopted by the LSC for all-sky searches for continuous gravitational wave sources like neutron stars (see sec. 3.2.4 Computational innovation). In the last decade, gravitational wave data analysis, together with elementary particle physics, pioneered the development of “grid” computing as an environment for distributed computing. These activities are now driving the evolution to the next-generation “cloud” environment, moving from static, parameter-sweep, batch-mode processing to dynamic, heterogeneous, interactive processing. Computing clouds are rapidly being rolled out by leading-edge commercial providers to utilize idle capacity in giant data centres. This utility model

* The LIGO data analysis relies heavily on Condor (<http://www.cs.wisc.edu/condor/>) to manage complex workflows. It has spawned new functionality now available to other communities in official releases of Condor.

The LIGO Data Replicator (LDR) is used to replicate interferometer data in bulk to analysis sites through the Globus GridFTP and Replication Location Service (<http://www.globus.org/>). Globus services based on LDR are widely available to other communities.

Pegasus (<http://pegasus.isi.edu/>) is used by certain kinds of LIGO searches to manage large, complex, data-intensive workflow planning. This is driving new functionality, scalability, and robustness in the Pegasus suite of tools.

TclGlobus offers functionality to allow the Tcl/Tk scripting language to use the Globus Toolkit, and enables grid interfaces in Tcl software simply by including the TclGlobus package. TclGlobus (<http://tclglobus.ligo.caltech.edu/>) was developed entirely by the LIGO Scientific Collaboration and is available to other communities.

of computing (renting software and CPU cycles) is likely to usher in a revolutionary new usage paradigm for the public and business at large.

As well as contributing to technical advances in hardware and software, gravitational wave science has driven distributed computing in structural directions like workflow planning, management and execution, data replication, and data placement for computation*.

The move from grid to cloud computing is part of a wider process of virtualization, i.e. the transparent federation of distributed computing resources like data centers. LIGO-Australia offers a unique, advanced test-bed for these new ICT technologies. For example, LIGO mandates strict conditions on system variables (e.g. operating system configuration) in its data analysis program and has therefore pioneered the development and use of portable platforms like virtual machines. Data handling processes include discovery, sharing, integration, storage, and curatorial management of long-term, complex data sets; network needs include backbone connectivity for data transfer from instruments in very remote locations. Software tools are being developed for load balancing, application scheduling, authentication, real-time visualization of complex data, and real-time simulation.

Advanced signal processing: Gravitational wave science is at the cutting edge of developing smart algorithms to search for weak signals, with wide applications in remote sensing. Cross-over includes harmonic detection with matched filters and phase unwrapping techniques, which are widespread in electrical engineering problems. Low signal-to-noise problems with security applications are another area of commonality, e.g. detecting small, fast-moving objects against a background of sea-noise clutter, using advanced adaptive filtering techniques, a rare example of a signal processing problem which is comparable in difficulty to gravitational wave detection (80dB below the noise) and which shares many common features, e.g. designing an optimal library of illumination templates.

4. Promoting an innovation culture and economy

Fundamental science is a powerful driver of innovation. The spectacular advances in gravitational wave detectors, reaching measurement sensitivity ten thousand times smaller than the size of a nucleus, have only been possible through sustained innovation. In some cases, this has been achieved through invention, for example, the invention of quantum non-demolition techniques. In other cases this has been achieved via innovation: the application of known techniques in new and clever ways. For example, the multiple pendulum suspensions which isolate against seismic noise, or the adoption of

microwave locking techniques. This drive to innovate will inculcate such attitudes and ways of thinking in our graduates, many of whom will take these skills with them into high tech industries, as many past graduate students have done.

In turn, inventions and techniques developed in the quest to build gravitational wave detectors will be taken up in other areas and by smart industries.

Examples of such innovation to date include: applying laser stabilization and control techniques to optical fibre sensors to produce the world's most sensitive fibre sensor arrays (now being developed under a Linkage Project with Benthic Geotech) and for highly sensitive atmospheric pressure spectrometers (being developed under a Linkage grant with the National Measurement Institute and Australian Scientific Instruments); and vibration isolation technology licensed to Fugro Airborne Services for use in airborne mineral exploration.

Gravitational wave education and public outreach stresses innovation, new ideas and new ways of thinking. In the public outreach centre at the LIGO-Australia site the Wesfarmers Innovation Gallery is used to demonstrate innovations not only in gravitational wave detection, but from other innovators in Australia so as to promote a culture of innovation. The goal is to show how innovation brings prosperity, discovery and improvement to human wellbeing.

3.1.2 OTHER NATIONAL RESEARCH PRIORITY AREAS

The application of technology developed for gravitational wave detectors such as Advanced LIGO to measurement devices is already having an impact in other National Priority Areas:

Sensing technologies led to the development of ultra-sensitive passive fibre arrays for oil and gas exploration and security applications. These provide a robust, effective and non-polluting way to monitor undersea oil deposits and for perimeter security. Other examples are:

- Vibration isolation technology in airborne gravimeters and gradiometers.
- Low frequency data from gravitational wave detectors to extract information on seismic events on earth, both natural and anthropogenic.
- Technology developed for space-based gravitational wave detectors being adapted for Earth Observation Systems such as for a future upgrade to the Gravity Climate and Recovery (GRACE) mission.

- Lasers for laser radar, atmospheric sensing and vibrometry, for defence and environmental applications.

By working closely with industry and other end users there is little doubt that such spinoffs will continue to flow as gravitational wave scientists further develop optical sensor technology.

3.2 NATIONAL INNOVATION PRIORITIES

To complement its National Research Priorities, the Australian Government has adopted seven National Innovation Priorities across 5 broad themes: 1) increasing the number of research groups performing at world-class levels; 2) producing skilled researchers; 3) fostering industry and business engagement in the development and use of IP and new technologies and fostering community and sector wide collaboration; 4) increasing international collaboration in research by Australian universities; and 5) improving policy development and service delivery. LIGO-Australia will play a major role in support of the first 4 of these themes.

Theme 1. Increasing the number of research groups performing at world-class levels

Prior to the formation of the LIGO Scientific Collaboration (LSC) in 1997 there were fewer than 50 scientists actively engaged in gravitational wave detection in the US. Thirteen years later, the LSC has 487 members from 38 institutions across the US plus 339 members from 23 institutions outside the US, for a total of 826 and steadily growing. It meets twice per year and at each meeting on average 3 new groups apply to join. Physics faculty advertisements in the US regularly feature gravitational wave instrumentation and astronomy. One of the unique features of the LSC, compared with many other large physics collaborations, is that it encourages researchers from small universities to participate, and many of them have contributed significantly to the results of the collaboration.

As a major on-shore Australian physics and astronomy facility, LIGO-Australia will seed similar growth here. Currently, Australia has a total of 50 researchers across 5 universities engaged in gravitational wave research through the LSC and ACIGA. Because of the diverse problems involved in gravitational wave research, there will be opportunities for physicists, astrophysicists, engineers, applied mathematicians, computer scientists, information technologists, educators and technical experts. LIGO-Australia and its associated data analysis facilities will provide a major facility for researchers at smaller regional universities to access and analyse high quality fundamental physics and astronomy data. Nurtured by the global gravitational wave community these groups can also produce world-class outcomes.

This project is expected to increase the numbers of researchers directly involved with gravitational wave physics in Australia, by a factor of four. (This estimate is based on LIGO's experience in the US).

Theme 2. Producing skilled researchers

Skilled people are the single most important prereq-

uisite for successful innovation. Accompanying the growth in research groups engaged in LIGO-Australia will be a multitude of opportunities for PhD training across a range of disciplines. The ongoing stream of discoveries, plus active public outreach, will put the field into public view, inspiring young people and increasing the pool of physics students. The breadth of the field, from instrumentation to data analysis, to astrophysical interpretation and cosmology of the early universe ensures that the field will strongly promote novelty and innovation in national priority areas of smart information use, breakthrough sciences, and frontier technologies. Doctoral candidates in gravitational wave instrumentation and astronomy will double throughout Australia to 80 - 100 within three years of operation.

Theme 3. Fostering industry and business engagement in the development and use of IP and new technologies and fostering community and sector wide collaboration.

Increase in the number of businesses investing in R&D. Increase in the proportion of businesses engaging in innovation over the next decade. Increase the level of collaboration between Australian businesses, universities and publicly-funded research agencies over the next decade.

The LIGO-Australia project will work in close partnership with several industry partners. Industry involvement and cost-effective solutions are intrinsic to the project.

One critical technology for this project is ultrahigh vacuum stainless steel pipe manufacturing.

LIGO pioneered the use of spiral welded stainless steel for high vacuum application. This technique will be transferred to an Australian company to use for on-site pipe manufacturing to greatly reduce transportation costs. These new capabilities will enable the company to bid for overseas jobs without a transportation cost penalty.

LIGO worked closely with the Australian Centre for Precision Optics (ACPO) of CSIRO to develop the highest quality optical coatings. ACPO will benefit from having a local end-user and will be able to monitor their coating performance and rapidly respond to problems. The project will increase their visibility and engagement with the precision metrology community.

Other areas where business engagement will be sought include advanced electronics, digital control systems and high performance computing.

Past successes in this area highlight how such business partnerships can result:

- Gravitec Instrument research labs relocated to Perth from Auckland to embark on joint industry projects funded through their head office in London. They chose this strategy to benefit from the precision metrology and vibration isolation used in gravitational wave research, and also to be close to the mineral exploration industry.
- Fugro Airborne Services connected with ACIGA to be able to license IP in vibration isolation technology required for airborne mineral exploration.
- Benthic Geotech licensed IP in laser stabilization applied to passive fibre sensor arrays for undersea monitoring. Following a successful Linkage Project with ANU this company is now seeking partners for a sea trial of the technology.
- Education Sector partnerships: ACIGA has partnered with non-profit organisations and the WA Education Department and the Gravity Discovery Centre in public outreach and school education.

Theme 4. Increasing international collaboration in research by Australian universities.

Gravitational wave observatories differ from other 'big science' (~\$1B) facilities (particle physics accelerators and large telescopes) in one very important way. Gravitational wave astronomy requires an array of detectors of similar sensitivity spread around the globe, working together in close coordination. Unlike particle accelerators or telescopes where a single large facility is built and collaborators travel to that one location, the network of gravitational wave detectors will produce a flow back and forth of collaborating, world-class researchers travelling among the detectors. With LIGO-Australia, the Australian research community (particularly the physics community) will benefit from having an on-shore research facility rather than a share in an distant international facility.

The current gravitational wave collaborations involve a community of more than 1000 researchers (about 830 from the LSC alone) from over 15 countries working together to develop exquisitely sensitive instruments, conduct research and development to enhance their sensitivity, analyse data, develop new signal processing techniques, predict source waveforms and interpret results. Australian research groups joining LIGO-Australia will automatically be put into collaboration with other international groups pursuing similar activities. The gravitational wave community has been an early adopter of techniques for remote collaboration including remote conferencing, shared workspaces, electronic log-books and wikis. All scientists who join LIGO-Australia will become members of the LSC with joint authorship rights for papers based on LIGO data. As discovery papers begin to appear, this inclusive authorship policy

will greatly benefit the publication output and research standing of the member institutions.

By joining with the USA to build LIGO-Australia, Australia will become a partner in truly international science of Nobel Prize significance.

Advanced LIGO is already international with partners from UK, Germany and Australia. LIGO-Australia will bring with it the UK and German partnership.

LIGO-Australia can also provide the basis for developing Asia-Pacific based collaborations. ACIGA leadership has signed MOUs with consortia in India and China who wish to join LIGO-Australia. Both collaborations have been funded (via the Australia China Council and the Australia-India Strategic Research Fund). This has led to Chinese student visits to work at the Gingin facility, joint conferences in Pune and Shanghai, and major funding for the Indian consortium to build an experimental facility at the Tata Institute for Fundamental Research, Mumbai. The Indian side proposes \$20M funding contribution to enable India to supply vacuum tanks and other components for the project, thereby allowing India to play a major role in LIGO-Australia.

3.3 NATIONAL EDUCATION PRIORITIES

The Australian School Science Education National Action Plan 2008-2012 (D Goodrum and L J Rennie 2007) has recommended Priority Actions for science education. The report notes the well documented decline in senior high school science enrolments, the matching decline in tertiary science enrolments, and the consequence: an increasing shortage of workers with science-engineering-technology skills. In reviewing science education it notes that “there is a perceived lack of relevance, particularly for secondary students, in much of the current science curriculum as it is implemented in the classroom,” and that there is a need for science teachers to have “contemporary science content knowledge”. The report states that “engaging students in science in ways that promote meaningful learning cannot be achieved without curricula that are meaningful to those students”, that “there is need for improved community understanding and awareness about science” and that “a national effort is required to encourage young people to consider taking up those careers.”

Physics in particular suffers from these problems. Studies of student attitudes find that there is a perception that physics is boring. A symptom of the above problems is the current shortage of teachers trained in physics.

Under Priority Actions the report recommends:

- Engaging the science community as a resource for teachers to promote their contemporary science knowledge, by mentoring and by short term placement in science and industry.
- Developing and implementing curriculum and professional learning resources for the upper secondary science areas, in particular for physics, chemistry, biology and general science.
- Facilitating and coordinating the national development of educational digital publishing in providing curriculum resources.
- Encouraging media coverage of stories that identify science-related issues, thus promoting science, scientists and science-related careers
- Identifying underserved rural and remote areas and ensuring adequate funding to provide outreach on a regular basis.

The LIGO-Australia project will provide a vehicle to address all of the above Priority Actions, particularly through Public Outreach and by extending existing local efforts to become national activities, as discussed under Education Efforts in Section 3.4.

LIGO-Australia can raise the profile of physics for the public because it will be making ongoing discoveries that will fascinate and inspire young people. General relativity has always had a fascination for the public, and a large pioneering facility making important discoveries in Australia will be judged newsworthy by the Australian media.

The sources of gravitational waves can be explained to the public in exciting and informative ways that other physics phenomena (e.g., the Higgs boson) struggle with. Thus, the detection of gravitational waves and exploration of a brand new spectrum has the potential to fuel a resurgence in interest in physics. The new discoveries and the new physics will inspire young people, attracting more into physical science and helping to reverse the decline in science and technology career choices.

A facility like LIGO-Australia can similarly be used to attract teachers for further training and for updating skills in science. We propose to provide teacher sabbaticals and short training courses to upgrade the cadre of science teachers, both locally and nationally. Our focus on teacher sabbaticals, development and provision of

learning materials both physical and online, will develop better teachers with better resources, more able to pass on modern concepts and enthuse their students. These teachers will be in a position to lead the revision of the physics curriculum to incorporate current understanding of nature and how they relate to everyday experience. They will be able to change the perception of physics as old fashioned, hard and boring to something exciting, challenging, mysterious yet understandable.

The combination of a research facility and a teaching science centre, exemplified by the current Gravity Wave Discovery Centre, is a very powerful one. Although some aspects of LIGO-Australia are outside the normal range of school science education, many of the fundamental concepts are core to science education. The real world value of simple harmonic motion, waves, and optics can be emphasized to students. LIGO has pioneered using its facilities to attract school visits, letting students tour a working science facility and meet a working scientist (for most their first!), and then reinforcing the importance of the concepts they are learning in school applied to real-life. The popularity of this program is evident—one month into each school year, every available date for school visits has been booked.

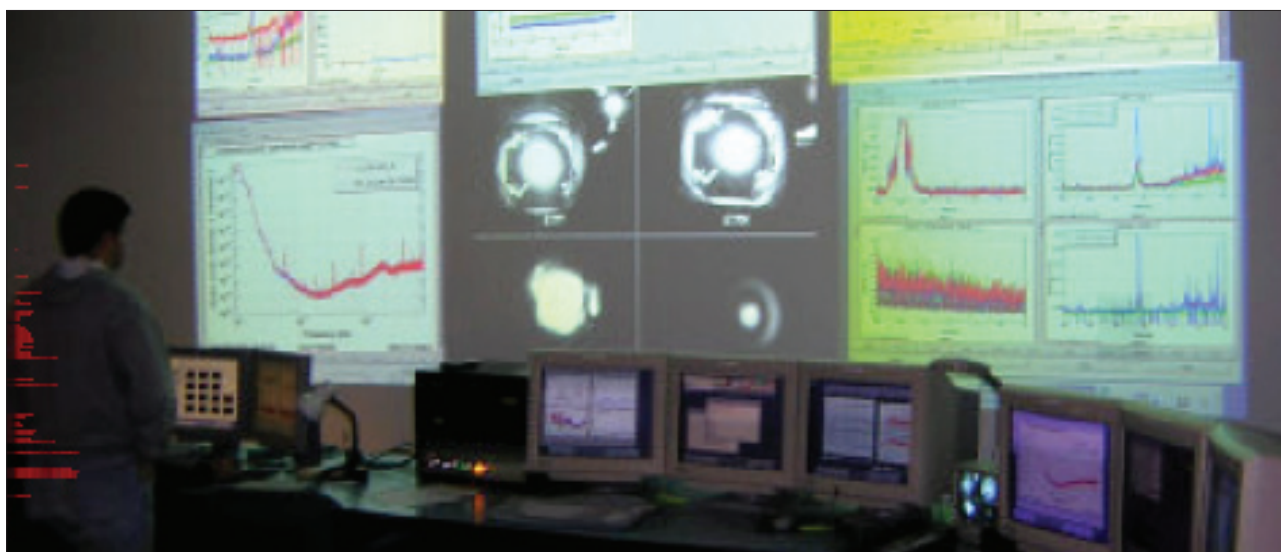

Imagine the transformational potential of a young student's first encounter with a working scientist

The combination of a working scientific facility with an informal science learning centre is a very powerful one. LIGO's site in Louisiana is in a rural area, which is underserved by traditional educational means. By building its Science Education Center directly adjacent to its research facility, LIGO has become a favored destination for school groups. Every school group visit includes a tour of the facility (consistent with non-interference with on-going scientific operations).

By far the most popular part of the facility tour is the control room, where the operators and scientists monitor and control the detector. There students get to meet and talk with one of the scientists on duty, usually a visiting scientist from the broader LIGO Scientific Collaboration. For most of these students, it is the first time they have ever met a professional scientist. We can only speculate how many future scientists received their first inspiration at LIGO, but what is certain that the most common beginning to the letters LIGO receives from students is "I used to hate science, but..."

Figure 3.1 A LIGO control room.

3.4 NATIONAL ENVIRONMENTAL PRIORITIES

The Australian government has placed high priority on preserving the nation's unique diversity and on sustainable practices. The LIGO-Australia observatory will demonstrate high technology existing in harmony with the environment. It has been planned not only to minimise environmental impact but to improve the long term preservation of its large high biodiversity bushland site through wise environmental management practices. It will provide positive environmental benefits both locally and nationally through demonstration, education, and public outreach as well as through hosting ecological and environmental research. It will use both photovoltaic and geothermal renewable energy that will impact positively on the wider community through education and public outreach programs. Environmental sustainability is already a central focus for the education centre on the site.

The project will serve as a model to show how large scale high technology facilities can achieve environmental sustainability.

Protecting Flora, Fauna, and Cultural Heritage

The LIGO-Australia site is within an internationally recognised biodiversity hotspot and supports rare plants and habitats for rare birds. The site is within a 50km² area of state forest, consisting mainly of banksia woodland. Its use for a large scale gravitational wave observatory has been planned with environmental considerations in mind. Prior to obtaining a lease on the LIGO-Australia site two environmental surveys were completed and environmental management guidelines were agreed

with all stakeholders including the indigenous custodians of the land. A formal agreement with the indigenous custodians (the Nyungah Circle of Elders) was signed by ACIGA before UWA negotiated a long term peppercorn lease with the WA Government. The lease includes the land required for the observatory and public outreach facilities plus access to the land required for the two 4km vacuum arms (configured in an L-shape) required for the large scale interferometer. Since the site was occupied for gravitational wave research and public education, an environmental management plan has been implemented, designed to minimise human impact on the site. Priority has been given to prevention of weed infestation and forest dieback disease, and fire risk mitigation using large scale sprinkler systems in the bush.

Sustainable Design and Renewable Energy

Precision measurements such as those made by LIGO-Australia, require precise temperature control of the buildings, a requirement that usually leads to high energy consumption. We intend to show how geothermal cooling can be used to provide precise temperature control while still minimising energy usage. The Gngara water mound is a large body of underground water which is an important water source for Perth, and which also provides the site with a low temperature geothermal source for air-conditioning. Prototype low-energy consumption geothermal air-conditioning systems were developed for the research laboratories on site and for the Gravity Discovery Centre. These prototypes were studied extensively in two UWA engineering honours projects with Alternative Energy Development Board funding, confirming that the energy use was environmentally benign. The large scale installation required for LIGO-Australia will also make use of similar



Figure 3.2 Bushland on the LIGO-Australia site.

geothermal cooling. It will be a precision air-conditioning system using a fraction of the power required for conventional systems. Through our education and public outreach, we will promote such systems, thereby ensuring that the environmental benefits of such systems become well known.

Like most high technology research facilities, LIGO-Australia requires high quality power. The most environmentally sensitive way to provide this power is through use of a grid-connected photovoltaic power system combined with on-site DC power storage and high efficiency LED lighting. This minimizes the use of non-renewable resources and also provides extremely clean DC power for critical applications. LIGO-Australia will be a net supplier of energy to the grid. This will reduce the need for upgrading nearby transmission lines and will have a positive impact in reducing Australia's CO₂ emissions. Again, further benefits will accrue through our ability to publicise these benefits through our public outreach program.

The largest structures in LIGO-Australia are the vacuum beam tubes—1 m diameter stainless steel pipes that extend the length of the perpendicular 4 km long arms. At the US LIGO facilities these were covered with concrete arches which create long barriers to both human and animal movement. LIGO-Australia will protect the beamtubes by earth berms and shallow domed covers designed so that they will not impede wildlife movement. Power lines and cables will be buried so that they are resistant to bushfires. Roadways beside the vacuum arms will act as high quality firebreaks to assist in the fire management of the site.

Sustainable Construction and Operation

LIGO Australia requires large scale stainless steel vacuum pipes. These will be manufactured using an innovative on-site production system which will improve reliability and greatly reduce the transport costs and truck movements, leading to both cost savings and energy savings. The cost effective nature of this production is expected to lead to wide uptake of the technology which will again multiply the environmental benefits.

Vehicle usage is also a concern for LIGO-Australia. An onsite accommodation block will support visiting scientists and students to minimize the need to commute to distant accommodation. Vehicles used to access the stations at the ends of the arms will be plug-in electrical vehicles where possible. The LIGO-Australia site will be protected against vehicle access, such as recreational 4WDs, to prevent seismic disturbance. This will have added benefits in ensuring the preservation of the site, consistent with the goals of the WA Dept of Environment and Conservation which manages the site.

Environmental Research

In collaboration with the Water for a Healthy Country Flagship project of CSIRO Land and Water, the site will host an atmospheric flux station to monitor fluxes of momentum, energy, water vapour and CO₂ in the environment. The location was chosen because of the ability of LIGO-Australia to protect the site. Research data will be made continuously available to the public outreach centre. (project funded through the Commonwealth National Collaborative Research Infrastructure Strategy/Terrestrial Ecological Research Network).

In collaboration with The Curtin Institute for Biodiversity & Climate, the site will be used for long term biodiversity monitoring, as part of a study of the environmental impacts of climate change in Western Australia.

4 COLLABORATION

Due to the need for a global detector array, the field of gravitational wave detection has evolved into one in which broad international collaboration is the norm.

Today, even in the absence of any confirmed detection, over 1000 scientist, engineers, and students in more than 15 nations are engaged in this work. As the international network moves into an era of regular observations of gravitational waves, LIGO-Australia offers fertile ground for increasing participation from Australian scientists and for building international collaborations that will enhance the standing of Australian science on the world stage.

4.1 CURRENT LIGO-AUSTRALIA COLLABORATORS

LIGO-Australia has two major collaborating organisations: the Australian Consortium for Interferometric Gravitational Astronomy (ACIGA), and the LIGO Laboratory.

Australia has a long history of research into laser interferometry for gravitational wave detection dating back to an initial collaboration between The University of Western Australia and The Australian National University in 1990, with the University of Adelaide joining in 1995 to form ACIGA. ACIGA now consists of 5 universities (Figure 4.1) and has over 50 scientists, technicians and PhD students. It has expertise across the main interferometer subsystems: suspension and isolation at UWA, high power lasers at Adelaide and optical, quantum optical and control systems at ANU. At its Gingin site, ACIGA operates 80m long suspended cavity interferometers for testing high optical power effects. It has active data analysis groups at The ANU, UWA, The University of Melbourne and Monash University. ACIGA is already a partner in Advanced LIGO supplying components for optical and suspension systems, paid for by



THE UNIVERSITY OF
WESTERN AUSTRALIA
Achieve International Excellence

The UWA group has particular expertise in

- Vibration Isolation
- High power optical interactions
- LIGO data analysis
- Multimessenger astronomy



The Adelaide group is expert in

- Lasers
- Optical distortion measurements



THE UNIVERSITY OF
MELBOURNE

The Melbourne group does research in

- Data analysis
- Neutron star physics



The ANU group has extensive experience with

- Quantum measurements
- Servo-controls
- Thermal noise in optics
- LIGO data analysis



The Monash group is engaged with

- Multi-messenger astronomy
- Thermal noise in optics

Figure 4.1 The Australian Consortium for Interferometric Gravitational Astronomy (ACIGA) is the main organisation that coordinates Australian research using ground-based interferometric detectors. It is led by groups at five Go8 universities.

an AU\$2M LEIF grant from the ARC. ACIGA is a founding member of the Gravitational Wave International Committee (GWIC). GWIC is a sub-panel of the Particle and Nuclear Astrophysics and Gravitational International Committee of the International Union of Pure and Applied Physics (IUPAP), and is the main international body for gravitational wave physics.

Since its formation, ACIGA has produced approximately 50 PhD graduates. Many of them (17) are still in the field working for LIGO, GEO, Virgo and in Australian institutions in faculty or research only positions. Others have moved into related fields now occupying positions in institutions such as JPL, holding posts at Australian universities (16) and in related Australian industry and defence. A number of former ACIGA students, postdocs and visitors have indicated their enthusiasm for the project and a possible interest to join the project to help build LIGO-Australia. This body of experienced staff ready to begin work immediately is one of the reasons why LIGO-Australia can be undertaken on the short timescale needed by LIGO.

The construction of LIGO-Australia and its associated data analysis facilities will see major growth in the field of gravitational wave astronomy and synergistic sciences and technologies (see Linkages section) across Australia. Furthermore, it will encourage collaboration between the Go8 universities managing LIGO-Austral-

ia and other universities as the opportunities in data analysis, astrophysics and newest technology became apparent to the broader physics and astrophysics community.

We expect that past and present members of ACIGA will form the nucleus of the LIGO-Australia team, but we also expect interest from overseas scientists who might join the effort. During the construction of the LIGO-Australia facility and vacuum system, Australian scientists, engineers and technical staff will participate in the installation and commissioning of the US Advanced LIGO detectors, acquiring first hand knowledge of the Advanced LIGO systems and the critical expertise required to build LIGO-Australia.

The LIGO Laboratory (Figure 4.2) is a United States national facility for gravitational wave research, managing the construction and operation of the LIGO detectors, while providing opportunities for the broader scientific community to participate in detector development, observations, and data analysis. The initial LIGO is a system of three interferometric Fabry-Perot detectors, two of them 4 kilometers long and the third one 2 kilometers long, aimed at the simultaneous detection of gravitational waves in the frequency range 40-6000 Hz. LIGO has been built in Hanford, Washington and in Livingston Parish, Louisiana (USA) and began observations in the year 2002. LIGO was also a founding member of the Gravitational Wave International Committee.

The LIGO Scientific Collaboration (LSC) is an independently governing scientific collaboration. The LSC is composed of approximately 830 individuals from 61 institutions worldwide, including scientists and engineering personnel from the LIGO Laboratory. LSC membership includes all of the scientists and students in ACIGA. ACIGA scientists have the same rights and privileges as any other LSC members.

The LIGO Laboratory is currently in the midst of a program to install and commission the Advanced LIGO detectors. The Advanced LIGO detectors incorporate new technology developed by the LIGO Laboratory and the LSC to gain approximately a factor of 10 in sensitivity. This will enable them to detect signals from ten times farther away, increasing by one-thousand-fold the volume of the universe which can be observed. Advanced LIGO and its other international partners (Advanced Virgo in Pisa, Italy and LCGT in Japan) are poised to open an entirely new way to view the universe. LIGO-Australia will be an important member of that international network.



4.2 POTENTIAL FUTURE PARTICIPANTS

In many ways, gravitational waves represent a new field of study in astronomy and physics. While the community of scientists engaged in detector development has existed as a vibrant field of experimental science for several decades, the absence of confirmed detections has kept the number of scientists who devote large portions of their research to gravitational waves low. Anticipation of the first detection is already drawing attention from astronomers interested in transient phenomena and relativistic astrophysics, including astronomers associated with two major Australian observatories: ASKAP and Skymapper. (Figure 4.3) The growing interest among astronomers in combined gravitational wave/electromagnetic observations is evidenced by the number of papers submitted to the US Astronomy Decadal Survey Panel*.

There is also the potential for significant international participation in LIGO-Australia. The scale of this detector makes regional partnerships in its construction and operation highly desirable. To date discussions about possible collaboration have been undertaken with groups in India and China.

4.2.1 INVOLVEMENT WITH MAJOR NATIONAL RESEARCH ORGANISATIONS

ACIGA has close contacts and involvement with three key Australian research organisations CSIRO, DSTO, and Geosciences Australia. Each organisation has much to contribute to the project, and ACIGA encourages their participation.

* Even though (as an already funded effort) Advanced LIGO was not being evaluated by the US Astro2010 Decadal Survey, a number of the science white papers submitted by the astronomy community cited the links to gravitational waves in their discussions of the important science they see for the next decade. These white papers include:

Bloom et al. <http://www8.nationalacademies.org/astro2010/DetailFileDisplay.aspx?id=18>

Kulkarni et al. <http://www8.nationalacademies.org/astro2010/DetailFileDisplay.aspx?id=191>

Phinney et al. <http://www8.nationalacademies.org/astro2010/DetailFileDisplay.aspx?id=350>

Soderberg et al. <http://www8.nationalacademies.org/astro2010/DetailFileDisplay.aspx?id=220>

Stamatikos et al. <http://www8.nationalacademies.org/astro2010/DetailFileDisplay.aspx?id=373>

Wozniak et al. <http://www8.nationalacademies.org/astro2010/DetailFileDisplay.aspx?id=281>

Nelemans et al. <http://www8.nationalacademies.org/astro2010/DetailFileDisplay.aspx?id=376>



The Australian Skymapper project, led by ANU Australian Laureate Fellow Brian Schmidt is typical of the broader user community we see for LIGO-Australia. *SkyMapper* is a state-of-the-art automated wide field survey telescope. With its robotic control, it can respond rapidly to alerts coming from LIGO-Australia and using the localization capability of the international network, can quickly point to observe possible gravitational wave sources. Skymapper is already operating in collaboration with LIGO and Virgo, and this collaboration will only grow closer and more effective with LIGO-Australia.

Figure 4.3 New Collaborators in Astronomy

a) CSIRO

i) Precision Optics: The CSIRO Australian Centre for Precision Optics (ACPO) was a major contractor for LIGO optics and is supplying key optical coatings for Advanced LIGO which includes the optics for LIGO-Australia. It will be of enormous benefit to the project to have ACPO involved in the end-use of their state of the art optical components.

ii) SKA and LIGO-Australia Synergies: CSIRO is leading Australia's bid for the SKA project. The LIGO-Australia project will offer significant benefits to the SKA project and will influence the chances of Australia winning the SKA site selection by demonstrating Australia's ability to manage a complex international project. The LIGO Scientific Collaboration is an exemplar for well managed international collaboration while the LIGO Laboratory has a proud record of delivering the LIGO detectors on time and on budget. LIGO-Australia will benefit from LIGO's experience, and LIGO's management skills will contribute strongly to enabling Australia to demonstrate capability in this area. Thus LIGO-Australia will help give international partners confidence to invest in the SKA project. Furthermore LIGO-Australia science is complementary and synergistic to that of the SKA. Already the proponents of both projects are working closely on both computational challenges and multimessenger astronomy.

Prof Peter Quinn is a co-chief investigator in an ACIGA ARC Discovery project developing computational tools

for multimessenger astronomy that will link the SKA, LIGO-Australia and optical telescopes (see below).

Likewise, the SKA project offers significant benefits to LIGO- Australia. ACIGA has held preliminary discussions regarding utilisation of the optical fibre link between Perth and Geraldton that passes close to the LIGO-Australia site, and also regarding utilisation of the computational facilities at the Pawsey Centre that are being developed to support the SKA.

iii) Advanced Computation: A team of ACIGA students and postdocs led by a Future Fellow is developing very high speed GPU computation tools at the International Centre for Radio Astronomy Research. The systems are designed for use both on the SKA and ASKAP radio telescopes and for gravitational wave data analysis specifically to allow rapid localisation of sources to enable radio and optical follow-up.

iv) Environmental research: CSIRO Land and Water is collaborating closely with ACIGA under their Water for a Healthy Country Flagship program in a project to monitor CO₂ fluxes on the LIGO-Australia site. Both projects require high quality environmental data, and the collaboration provides significant benefits to both projects. CSIRO has agreed to locate a meteorological tower near the mid-point of the proposed south arm of LIGO-Australia, and the Gingin research centre will support infrastructure, communications and scientists accommodation. CSIRO has committed to provide educational resources for the Gravity Discovery Centre involving real-time CO₂ monitoring, enabling students on enrichment programs to experimentally study the relationship between weather and CO₂ uptake on the Gingin site.

v) Vacuum Welding: The vacuum pipe welding technology proposed for LIGO-Australia was developed in conjunction with CSIRO Manufacturing and Infrastructure Technology but the collaboration ceased when the welding division in Adelaide closed down.

vi) Public Outreach: The Gravity Discovery Centre will soon take delivery of a 13m radio telescope provided by CSIRO, to support radio astronomy education and very long baseline interferometry. The GDC already has an educational exhibit on the SKA project.

b) DSTO

Lasers and Photonics: The Defense Science and Technology Organisation (DSTO) is one of the main developers and users of advanced laser and photonics technology in Australia, and they support all such technology for deployment with the Australian Defence Force. Over the years there has been very close synergy and collaboration between ACIGA universities and DSTO in this field.

The University of Adelaide in particular has collaborated with DSTO in laser technology which is a direct spin-off from the ACIGA's laser development for gravitational wave detection. Our work on frequency stable, coherent remote sensing for Doppler laser radar, vibrometry and more recently advanced, high power infrared fibre lasers, as well as topics in adaptive optics is a direct outcome. Collaborations extend to the local defence industry (eg BAe), and international collaborations (Northrop Grumman). This work has generated talented, senior laser scientists now employed by DSTO and BAe, who have graduated from work originating with ACIGA. ACIGA would welcome DSTO involvement in LIGO-Australia.

c) Geosciences Australia

i) Magnetic Observatory: ACIGA has been in collaboration with Geosciences Australia in the development of the Geosciences Australia's Gingin Magnetic Observatory since 2004. ACIGA facilitated the co-location of this observatory to the LIGO-Australia site to exploit the common need to utilise an extremely quiet site for sensitive measurements. ACIGA personnel assisted in the site selection, building design and provision of power and data.

ii) Seismology: In 2010 The Australian Society for Earthquake Engineering, in conjunction with Geosciences Australia, organised a study tour of ACIGA's Gingin research facilities and received briefings on advanced vibration isolation technology.

iii) Earth Strain Data: LIGO-Australia will generate extremely sensitive data on earth strains, earth tides and seismicity. In addition LIGO-Australia's electromagnetic monitoring and need for maintaining an electromagnetically quiet environment is synergistic with the operations of the magnetic observatory. Geophysical exploration systems already being developed as spin-offs from



Figure 4.4 IndIGO, the Indian Initiative in Gravitational-wave Observations, is an initiative to set up advanced experimental facilities, with appropriate theoretical and computational support, for a multi-institutional national project in gravitational-wave astronomy. The IndIGO collaboration is in the process of constructing a road-map and a phased strategy towards building a gravitational-wave observatory in the Asia-Pacific region. IndIGO has applied for funding to make a major contribution to LIGO-Australia.

gravitational wave technology are likely to be of interest to Geosciences Australia. Thus formal involvement in LIGO-Australia by Geosciences Australia will be welcomed.

4.2.2 REGIONAL COLLABORATION

i) India: IndIGO, (Figure 4.4) the Indian Initiative in Gravitational-wave Observations, is an initiative to set up advanced experimental facilities, with appropriate theoretical and computational support, for a multi-institutional national project in gravitational-wave astronomy. The IndIGO collaboration currently includes researchers from leading universities and research institutes, including Tata Institute of Fundamental Research (TIFR), Inter University Centre for Astronomy and Astrophysics (IUCAA), Delhi University, the Indian Institute(s) of Science Education and Research at Kolkata and Trivandrum, the Chennai Mathematical Institute (CMI), and the Raja Ramanna Centre for Advanced Technology (RRCAT). IUCAA is a member of the LIGO Scientific Collaboration. Several individual faculty members at the other IndIGO institutions have held postdoctoral appointments with LIGO and with Virgo.

TIFR has recently approved and funded a proposal from IndIGO for the construction of a 3-meter scale advanced interferometer prototype. The interferometer will be built initially at the Mumbai campus of TIFR. Stressing the lead TIFR has always taken in initiating frontier research areas, the Director and the Dean of Natural Sciences Faculty of the TIFR expressed their keen interest in seeding and developing experimental gravitational-wave research in India. This interferometer is essential for engaging and training students and postdocs in the required techniques to be able to participate in LIGO-Australia.



Figure 4.5 The conference banner for the IndIGO-ACIGA-LIGO Conference on LIGO-Australia in Delhi, 8 Feb 2011.

IndIGO strongly supports the construction of a gravitational-wave observatory in the Asia-Pacific region and has proposed to participate in LIGO-Australia.

IndIGO has signed an MOU with ACIGA and UWA, and is actively seeking funding to support its participation. IndIGO has contacted Dr. R. Chidambaram, the Principal Scientific Advisor to the Government of India seeking support for its activities. This request was informally reviewed, and IndIGO received encouragement to propose a capital contribution to LIGO-Australia construction of up to \$20M. This contribution would be made in kind, and would involve a mixture of high technology and other infrastructure contributions. There has been discussion of IndIGO taking responsibility for some portion of the vacuum system, which is one area of expertise for RRCAT because of its involvement with the Large Hadron Collider at CERN. We emphasize that no formal commitment has been made, but this is an indication of the potential international support which may be available.

ii) China: Recently, Chinese research groups at six leading Universities and research institutions interested in ground-based gravitational wave detection formed the China Gravitational wave Working Group (CGWG). The CGWG includes the Institute for Gravitational Research at Hua Zhong University of Science and Technology, Beijing Normal University, Tsinghua University, the National Institute of Metrology, University of Science and Technology of China and Nanjing University. Currently, the group at Tsinghua University is a member of the LIGO Scientific Collaboration. CGWG has signed an MOU with ACIGA and UWA. The Australia-China Council has funded a program to develop the CGWG Collaboration, and CHWG is actively seeking initial collaboration funding for participation in LIGO-Australia.

iii) Other Regional Collaborations: LIGO-Australia has the opportunity to become a focal point for regional scientific collaboration. Researchers in Korea, Taiwan, Thailand, Malaysia, Singapore, Indonesia and New Zealand have expressed interest in participating in LIGO-Australia. New Zealand has a strong tradition in both general relativity and quantum optics. The other nations plus China, are all in a common time zone with LIGO-Australia. This, combined with the fact that Australia has good educational and economic links with these countries, could provide the incentive for them to join this great world-wide project through participation in LIGO-Australia.

4.3 LINKAGES

As depicted in Figure 4.5, a gravitational wave detector is inherently a multi-disciplinary machine, covering at least 14 different fields.

Science Linkages: In terms of science, relativists will use gravitational wave data to provide insights into general relativity, the nature of space-time and gravity. Nuclear physicists will extract information on the behaviour of nuclear and exotic material under extreme conditions. Particle physicists will seek to understand conditions in the earliest epochs of the universe using a combination of accelerator and gravitational wave data. Important questions in astronomy and cosmology will be answered by astrophysicists combining gravitational wave data with data from optical, radio and gamma ray telescopes and neutrino detectors. Geophysicists will most likely extract interesting information on the behaviour of the earth's crust and core from low frequency data once LIGO-Australia and the global network are running for long periods of time uninterrupted. Quantum physicists will be able to probe the classical/quantum interface, so called quantum weirdness, with human size objects.

Computer Science Linkages: Driven by the needs of gravitational wave data analysis, computer scientists will have a vast data resource to develop and test better and faster algorithms for extracting weak signals buried in noise. The sheer volume of data, and the requirement

for international access (needs shared with the SKA) will stimulate those interested in GRID and Cloud computing (See discussion under 4.1.1 Frontier Technologies for Building and Transforming Australian Industries).

Instrument Science Linkages: The ongoing effort to make the instruments more sensitive will stimulate progress across many fronts: laser physicists build more powerful, stable and possibly different wavelength lasers; control scientists and engineers will integrate a multitude of sub- systems without interfering with the signal channel, employing adaptive algorithms to suppress direct Newtonian noise, and eventually to probe the limits of quantum control; vacuum technologists will build better UHV systems; mechanical engineers (working with control experts) will develop better suspension and isolation systems; materials scientists will extend the limits of purity and uniformity in mirrors and coatings across a variety of materials and a range of temperatures, and explore novel nonlinear materials for quantum applications; precision metrologists will push to exquisite sensitivity then apply knowledge to other sensors; and quantum metrologists will invent clever new ways of preventing the laws of quantum mechanics from masking the GW signals.

Cross Disciplinary Linkages: The needs of the different disciplines will lead to connections across discipline boundaries with the instrument users (astrophysicists, cosmologists, theoretical physicists, high energy

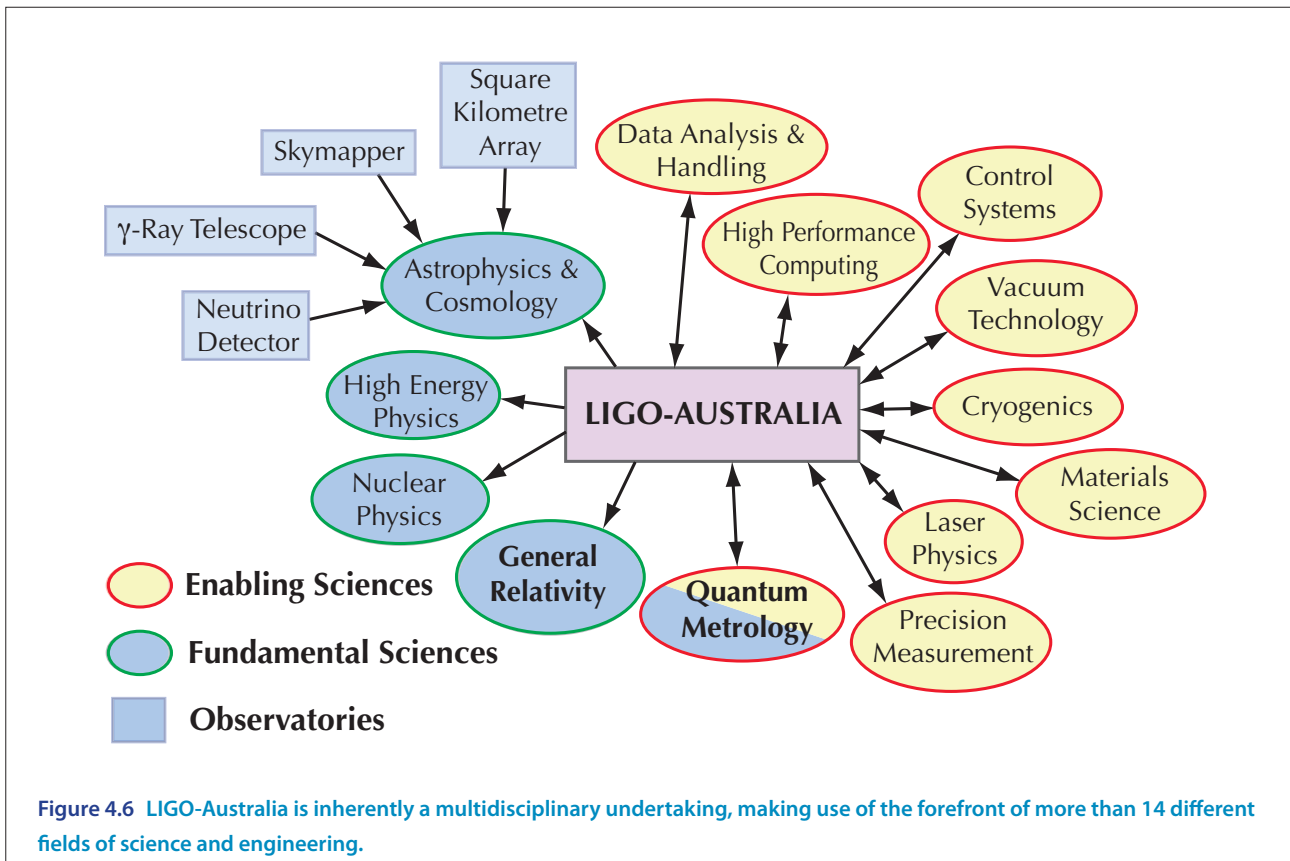

physicists) working closely with each other to enhance outcomes and with the instrument builders delivering the types of data (frequencies, sensitivities) they desire. Experimentalists will need to work together to ensure the integrated machine works effectively, understanding the impact each subsystem has on the other subsystems and the detailed interpretation and limitations of the detectors. All areas will be pushing the limits of their technologies driving innovation. Emerging high technology industries will seek close interaction with these researchers in order to exploit potential spinoffs.

Linkages to Centres of Excellence: Australia is particularly strong in quantum science, precision measurement science and astronomy. The recent ARC Centres of Excellence round saw the funding of 4 relevant centres: Quantum Computation and Communication Technology (CQC2T); Ultrahigh bandwidth Devices for Optical Systems (with interest in Astrophotonics); Engineered Quantum Systems (EQS); and All-sky Astrophysics ACIGA has strong links with these centres, and LIGO-Australia will resonate strongly with these communities. The EQS centre is exploring mechanical systems in the quantum regime (the classical/quantum interface) on the nanogram scale including opto-mechanics. Recent major international conferences in this emerging field (mechanical systems in the quantum regime) have featured gravitational wave scientists along with the micro- and nano-mechanical researchers. The CQC2T centre shares the development of quantum resources with gravitational wave research. Obviously LIGO-Australia and the Centre for All-sky Astrophysics will work closely together once gravitational wave detection becomes routine.

4.4 GOVERNANCE

LIGO-Australia represents a challenging project to manage for several reasons:

- The technological and scientific challenge of the project. Gravitational wave detectors are among the most precise measuring devices in all of physics. To achieve the required sensitivity and to improve them with time requires creativity, flexibility and recognition for individual contributions.
- The physical and financial scale of the project. The investment in the LIGO-Australia infrastructure requires careful monitoring and engineering discipline to ensure that funds are effectively and economically spent. The interplay of high precision engineering and frontier science requirements along with integration of techniques and methodologies across many sub-disciplines brings enormous complexity to the endeavour.
- Growth in the collaboration. The current collaboration members include quite a varied mix, with multiple Go8 universities, the LIGO laboratory and potentially other international collaborators. However, we fully expect that the number of collaborators will grow substantially, so any governance structure has to incorporate flexibility to accommodate new members from a variety of different institutions. The governance structure must allow for and accommodate this growth.

With these goals in mind, the governance structure has been constructed on the model which has been spectacularly successful in the US, adapted for the unique aspects of the Australian community. In the US, LIGO has evolved into two tightly inter-related organizations, the LIGO Laboratory and the LIGO Scientific Collaboration. These two organizations operate very differently, in recognition of the two conflicting needs of the enterprise. Managing the construction, operations and upgrades of the LIGO facility and detectors requires a project discipline with clear lines of authority and responsibility, and this is the province of the LIGO Laboratory. The scientific enterprise to develop the ultra-sensitive detectors, to use the scientific data to probe problems in astronomy and physics, and to guide the evolution of the field requires freedom and flexibility to foster creativity and innovation. The LIGO Scientific Collaboration (LSC) provides this structure. The LSC is a self governing organization of scientists — members join voluntarily and the LSC facilitates communication and collaboration, but coordinates their research activities only loosely. Scientists within the LIGO Laboratory are members of the LSC, splitting their time between their management-directed project activities and their LSC-coordinated research activities. Research groups from

the LSC outside of the LIGO Laboratory can take on tasks for the Laboratory through subcontracts to their home university, and on such activities they agree to be managed in a way comparable to the LIGO Laboratory staff. However, the majority of the outside research groups concentrate on curiosity-driven research.

The success of this model can be judged in many ways. The LIGO Laboratory was able to accomplish the LIGO construction task within budget and on schedule. At the same time, the LSC has grown substantially from roughly 100 members in 1997 to more than 830 today. LSC groups come from institutions ranging from major research universities to small teaching colleges. Each group finds a niche that it can fill and is valued for its contributions no matter how large or small. They propose to their funding agencies individually, and their performance is measured through the standards appropriate for scientific research. The self-governing nature of the LSC ensures that new ideas can arise at any level, be nurtured and mature, before being adopted by the engineering and implementation mission of the LIGO Laboratory.

Based on the success of this model, we have adopted a similar structure for LIGO-Australia as shown in Figure 4.7.

The construction and detector installation/commissioning project will be managed by a dedicated project team lead by a Director, while ACIGA will serve the role of coordinating and fostering the scientific research connected to LIGO-Australia.

The Director will report to the LIGO-Australia Board. The Board will be comprised of the DVCsR for the ACIGA Go8 universities, a representative from the Commonwealth government, The LIGO Laboratory Director, and representatives from international partners and other major stakeholders as appropriate. The Board will select the Director and periodically review his/her performance. They will provide oversight and assistance to the Director in defining major policies. The Director will be responsible for the whole LIGO-Australia project, including the budget, personnel, subcontracts and all aspects of the detector and its operation. The Director will coordinate his/her work with the LIGO Laboratory, with the Commonwealth and State Governments and other stakeholders, and importantly with ACIGA.

ACIGA will continue as a scientific collaboration. Its main focus will be research with and in support of LIGO-Australia, but research outside the main project will also be done. Individual university research groups within ACIGA may take on project tasks, through agree-

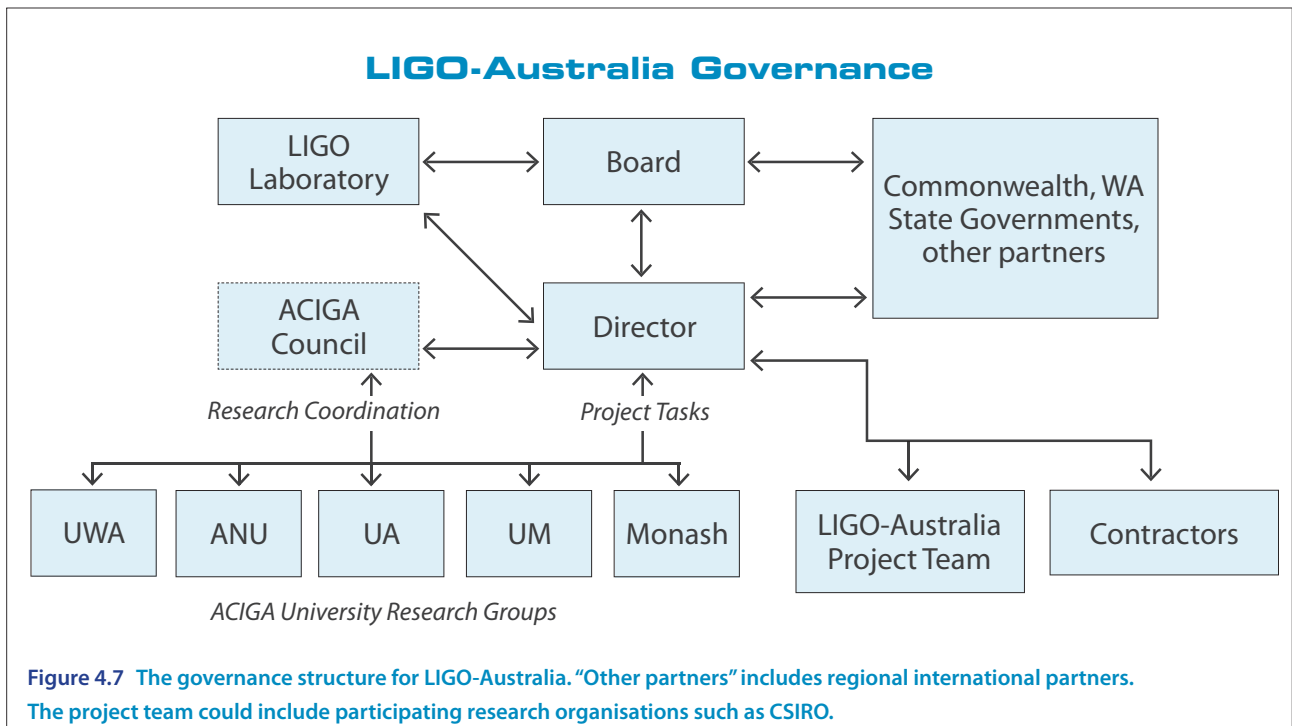

ments with the Director—these agreements may compensate the research groups for their allowable costs in support of the project tasks. On those project tasks, they will be responsible for cost, schedule and technical performance as if they were project staff, but on non-project tasks (e.g., their independently funded research activities) they will retain the independence appropriate for scientific research.

ACIGA will play a central role as the entry point for new collaborators from within Australia. New groups can join ACIGA and will receive mentoring and guidance to help them integrate and contribute in the most efficient way possible. ACIGA will encourage participation by researchers from other universities seeking to grow their research profile.

For researchers who want to use LIGO-Australia data, without the burden of participating in a large collaboration, there will be publicly available data products. The US National Science Foundation has charged the LIGO Laboratory to develop a data release policy for its approval. If LIGO-Australia is approved, Australian government opinions into this process will be an important input into the final guidelines. The goal is to make gravitational wave data from the entire international network available to researchers throughout the world to achieve the best science possible.

5 PROJECT FEASIBILITY AND BUDGET

There are several factors that determine the feasibility of a large science project or facility:

- **Technical Feasibility:** Have the technical requirements been specified properly to meet the scientific need? Will the facility as designed meet its technical and performance requirements? Are there undeveloped technologies that will cause cost or schedule overruns?
- **Schedule feasibility:** Is the schedule realistic? How well known are the durations of particular activities? Are there missing items or linkages in the project plan that will cause delays?
- **Cost realism:** Is the cost estimate realistic and reasonable? Have all costs been identified? Is the contingency adequate for the risks, or is it unduly “padded”?

In this section we discuss each of these factors and show how we intend to ensure success on all three legs of the project: Technical Performance, Schedule and Cost. Finally, we end with a Risk Matrix that summarizes risks in each of these categories, and shows the mitigation actions which reduce these risks to manageable levels.

5.1 TECHNICAL FEASIBILITY

The detailed technical challenges to build an interferometric gravitational wave detector have already been discussed in the previous sections. The detectors push the limits of technology on many fronts. To meet the sensitivity requirement, the detectors must operate at the fundamental limits of physical measurement; it is not possible to design the detector with a margin in one area to compensate for possible deficiencies in others. All parts of the detector must meet their stringent requirements:

- The lasers must operate continuously at high power with unprecedented frequency stability and intensity stability
- The mirrors must simultaneously meet stringent mechanical and optical requirements
- The suspensions for the mirrors must provide extremely high vibration isolation over a broad range of frequencies and not introduce excess noise at the level of thermal vibrations
- Control systems must balance low noise with high gain and dynamic range
- Sensitive analogue electronics must interface with high performance digital controls and software without compromising their low noise performance

Each one of these components represents decades of technology development to achieve the required performance, precision engineering to make it reproducible and reliable, and careful procurement management and quality assurance to ensure that the hardware delivered for the detector meets all requirements.

By allying ourselves with LIGO, the largest and best resourced gravitational wave detector project in the world, we are able to draw on their experience and resources to ensure technical success with LIGO-Australia.

Indeed, by using the components supplied by the LIGO Laboratory to construct the LIGO-Australia detector, we are assured of achieving their world-leading sensitivity, and can take advantage of their experience in installing and commissioning the detector to complete LIGO-Australia much faster than could be done with an untested design.

The remaining challenges are still substantial, but known to be achievable. The site buildings will need to

be designed (using Australian building standards) and built to demanding standards for cleanliness and low vibration. They must provide a stable environment for the detectors, including controlled temperature and humidity, quiet acoustic conditions and low electromagnetic noise. The experimental halls will be built with cleanroom materials and practices, and HEPA filters will remove dust from the air.

The vacuum system is also a technical and engineering challenge. The LIGO design for the vacuum system is somewhat unconventional, in that the number and distribution of pumps is far lower than would be used normally. This results in considerable cost savings (not only in the pumps, but also in the housings along the arm, power and control lines, etc). This design relies on two main technical achievements:

- the welds must be completely free of leaks
- the outgassing of the metal which forms the beamtubes is reduced by at least an order of magnitude below the conventional level.

For reasons of economy, the fabrication of the LIGO-Australia beamtubes will use spiral mill technology. This technology for making tubes is not commonly used for vacuum systems, but is a common technology for making other types of pipes. The vendor selected for the beamtubes will be instructed on the techniques for ensuring reliable leak-free vacuum welds.

LIGO pioneered the technology for achieving a 10-fold reduction in out gassing rate in 304L stainless steel (the type proposed for use in LIGO-Australia), through an inexpensive heat treatment process, prior to the spiral mill forming. This technology has never been used in Australia, but using the process specification from LIGO with careful management and technical assistance by the LIGO-Australia team to the vacuum system contractor, we are confident that the results achieved by LIGO can be reproduced here.

In short, although the project is challenging, we know that it is achievable, and by partnering with LIGO, we will have access to the specialized expertise needed to achieve success. Careful management and close attention by the LIGO-Australia project team will ensure that all technical specifications are properly interpreted and implemented in the designs. Furthermore, experienced LIGO staff can be called on to help if major problems arise.

5.2 SCHEDULE

There are two main factors that drive or constrain the schedule for LIGO-Australia. The most important schedule constraint is the first one: the decision to fund the project and to proceed. An over-riding constraint on the timing is the Advanced LIGO schedule currently in execution. Advanced LIGO is on schedule to begin assembly of the third interferometer by early 2011, and installation at the end of the third quarter of 2011. Any delay of installation activities past this point will cause overall project delay for Advanced LIGO, and this is unacceptable to NSF. Thus all necessary conditions for LIGO-Australia (commitments funding for construction and for operation, agreements on responsibilities, management agreements, etc.) must be met in time to secure formal approvals. LIGO and NSF have identified October 2011 as the deadline for agreement. If we are not able to give them assurances that the project is approved and will be funded by that time, LIGO will proceed with installation of the components for the LIGO-Australia detector at Hanford and this opportunity will be lost. This challenging schedule may not be achievable, but the unique opportunity makes it important that we try.

The second factor driving the schedule is that the early years of the international gravitational wave observations will be among the most exciting as new sources are observed, studied and understood. Facilities overseas already have a head start with LIGO already beginning installation of its Advanced LIGO detectors. Advanced Virgo in Italy is moving forward on a similar timescale. The Large Cryogenic Gravitational-wave Telescope (LCGT) in Japan was approved in 2010 and has started construction.

Our goal is to expedite facility construction and detector installation and commissioning so that LIGO-Australia can join the international network as soon as possible.

A draft project schedule is shown in Figure 6.1, based on the LIGO experience. Because the LIGO-Australia facilities will be closely modeled on the LIGO ones, the LIGO experience is highly relevant and should give a good approximation for the schedule. The following schedule description is based on actual durations experienced by LIGO during its initial construction (for the facilities) or planned during Advanced LIGO installation and commissioning. The final project schedule will be assembled using full engineering knowledge and inputs from potential contractors and sources for the various components. Then, using these inputs, we will create a master schedule that would link dependent

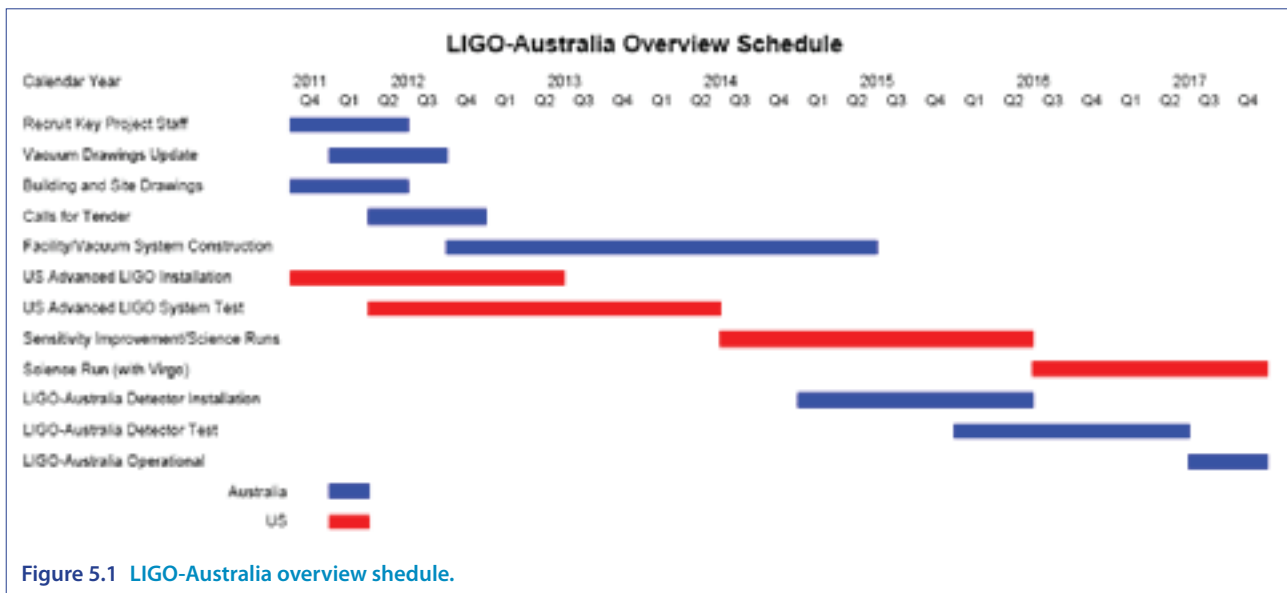

tasks on their predecessors. This process will identify the critical path. The robustness of the schedule will be assessed by the risks on the critical path and the possible uncertainties in other task lines. Pending this detailed schedule, the top-level schedule shown in Figure 5.1 can be used for preliminary planning purposes. This schedule also shows the relationship of LIGO-Australia activities relative to the US Advanced LIGO installation and commissioning activities.

Immediately after approval of the project the most urgent task will be to begin recruiting the project team. Many key scientific positions can be filled immediately from the well-established Australian gravitational wave science community. We anticipate that a number of Australian scientists working in the US and European gravitational wave projects will be interested in bringing their expertise back home. A few specialist positions are likely to be sourced internationally. For example, the lead high vacuum engineer might be drawn from a large project that uses high vacuum, such as a synchrotron or a plasma research project.

For the site and building design, we will plan to contract an experienced Architectural and Engineering firm. Site surveys (soil testing for foundation design, environmental surveys, etc.) will need to be carried out. The results of these will be combined with functional requirements derived from the original LIGO facility specification to develop the detailed construction drawings for the site plan and services, the buildings, and the foundation for the arms. Close interaction between the design firm and experienced project staff will be crucial to ensure that the facility will meet LIGO requirements.

For the vacuum system, the interfaces to the detector demand that the mechanical configuration be identical to the LIGO one. The drawings will need to be checked for completeness and accuracy, and will need to be

organised into bid packages. Some parts of the overall vacuum system will need to be updated, as some commercial components (gauges, valves, controllers, etc.) used in initial LIGO will have been superseded, and thus will no longer be available.

We estimate nine to twelve months to complete these design/design update activities. Assuming an October 2011 date for project approval, completed bid packages could be ready by mid-2012. At that point Calls for Tender on facilities and the vacuum system could be issued, in accordance with Australian requirements. Allocating three months to such a complex and expensive procurement is again aggressive, but possible, giving a late 2012 start to construction.

The next stage is the facility construction. Site preparation and building construction can go on in parallel with the fabrication of the vacuum chambers that house the sensitive interferometer components at the corner and end stations. Actual beam tube manufacturing and installation would need to wait until grading of the arms and foundation preparation along the arms is complete, but this need not be a delay since the tube mill will have to be constructed and installed on the site first. LIGO-Australia project engineering staff will interface with the selected contractors and monitor the progress and quality of the work. These staff will also coordinate closely with responsible LIGO Laboratory staff to ensure that Advanced LIGO needs are being met.

A top-down estimate for the duration of construction can be made based on corresponding time to construct the LIGO facilities. Including acceptance testing and bake-out of the vacuum system (necessary to achieve the cleanliness of the vacuum required), a realistic schedule for construction is three years, giving completion of the facilities in late 2015.

In parallel with the facility construction, the LIGO-Australia project team will prepare for detector installation and commissioning. Scientists to lead individual subsystems will be identified and will be supported to spend time in the US to participate in the US installation and commissioning tasks. This will engage the Australian team in the early science activities and will also give them essential experience to enable a faster and more reliable installation of the LIGO-Australia detector, as well as early experience in commissioning the detectors. The US-supplied detector components will be shipped to Australia and stored off-site until the facility is sufficiently far along to enable component assembly and initial installation activities. Many of the installation activities (for example the installation of the computer networking hardware and communication lines) can be done (and even in a few cases, be done more easily) before the final fit-out of the facilities is complete (beginning in 2014). Some of the instrument components can also be assembled in stringent clean room facilities to be assembled in the current Gingin laboratory buildings. However, the core installation activities (the in-vacuum installation of the mirrors and suspension systems) can only be obtained after the facility is complete, in the last half of 2015.

Once the facility is complete and its clean movable rooms have been brought into operation, in-vacuum detector installation work can begin. Using the experience of the first installations in the US LIGO facilities should enable the LIGO-Australia installation to proceed without difficulties or delays. Once the detector is installed the various subsystems will be integrated and tested culminating in first detector operation in 2016. The tuning process to bring it to full sensitivity should take about one year, again using the experience of US LIGO to avoid missteps and delays. The first extended scientific data run should come in 2017, marking LIGO-Australia's entrance into the global network.

5.3 COSTS AND FUNDING

Construction costs

To estimate the costs and to manage the work most efficiently with the Advanced LIGO Project, we have adopted the Work Breakdown Structure (WBS) shown in Figure 5.2. This WBS is modeled on the LIGO WBS structure, to enable the cost experience of LIGO to guide our cost estimate. The fundamental concept behind the WBS structure is that each element in the WBS has a defined scope of work, a cost estimate and a schedule. This ensures that all necessary work and cost is covered and covered only once. The WBS also serves as a project management tool. Once the project begins, work packages, consisting of defined tasks, budgets and schedules will be prepared based on the WBS, and task managers assigned to provide oversight and to take responsibility for accomplishing the work in each package.

This WBS has six second-level elements. The Project Management element (WBS1.1) provides for top level management and monitoring of the LIGO-Australia project. This includes system engineering and engineering management, as well as financial monitoring and reporting, quality assurance and safety. It also includes travel associated with project management, for example, for reporting to government, for interfacing with the LIGO Laboratory management, etc. This WBS element is a level of effort, and has been estimated using past project management experience (including initial LIGO construction) to scope the effort in terms of person-years for staff of different levels. Typical Australian labour rates have been used to convert to cost.

The next three WBS elements comprise the construction and outfitting of the facility. Two of these elements (WBS 1.2 Site Infrastructure and WBS1.3 Vacuum System) will be accomplished through a set of major subcontracts. These subcontracts will include an architectural and engineering contract to adapt the LIGO building designs to Australian standards and to develop site-specific construction drawings. The design and construction contractors will be retained during construction to assist with construction management and oversight. The cost estimate of this WBS element has been made by a leading Australian quantity surveyor, using means tables to convert the types and quantities (e.g., square metres of laboratory space) of buildings based on the LIGO model. The costing for geothermal cooling systems is based on experience with two systems already installed at the Gravity Discovery Centre and the existing Gingin research laboratories. Final cost figures were compared with the LIGO cost experience for reasonableness, but because of the difference in national construction standards and practices the LIGO costs were not used to adjust the quantity surveyor estimate.

WBS1.3 Vacuum System may be broken into more than one major subcontract, depending upon the scale and capabilities of the interested contractor pool. Interfaces between the major subcontractors will be the ultimate responsibility of the project system engineer, aided by the A&E firm as required. The LIGO vacuum system is rather unique in the world. To estimate the cost, we have used the LIGO cost experience, adjusted for the passage of time (inflated) and converted from US to Australian currency. Because the LIGO experience was more than a decade old, a qualified Australian company (Duraduct) performed an independent cost estimate. The Duraduct estimate was compared in detail to the inflated LIGO estimate to check for consistency and accuracy, and small adjustments were made.

WBS1.4 Site Equipment covers the costs of outfitting the facility with the general purpose equipment required to maintain the facility, unpack, clean and install the detector components, and to support operations. This includes the project labour to specify, order, receive, inspect and install such equipment. The majority of the equipment items in this element are commercial items, and catalog prices or vendor quotes were used for the estimate.

The remaining two WBS elements comprise the construction, installation and commissioning of the LIGO-

Australia detector itself. The sub-elements of WBS1.5 Detector map directly onto the WBS used by the Advanced LIGO Project. Under WBS1.5 there are 10 third-level elements comprising Advanced LIGO subsystems: Detector System Engineering, the Seismic Isolation Sub-systems (SEI); the Suspension Sub-systems (SUS); the Core Optics Components (COC); the Pre-Stabilized Laser (PSL); the Input Optics System (IO); the Auxiliary Optics Sub-systems (AOS); the Interferometer Sensing and Control (ISC); the Data Acquisition, Diagnostic, & Control (DAQ); and the Physics Environment Monitoring (PEM) subsystem. The LIGO laboratory will provide the finished and complete components for these eight elements of the Detector WBS. LIGO will be responsible for the safe packaging of the components for shipment. The LIGO-Australia project will cover the costs of shipping these products to the LIGO-Australia Gingin site in Western Australia. Each of these eight WBS elements under the Detector WBS has been studied to identify any elements which might not be provided by LIGO. This occurs in cases such as the DAQ subsystem: front end interfaces and computers, which reside adjacent to the detectors components, will be supplied by LIGO to LIGO-Australia, but other elements, such as the data recording processor and the control room workstation computers which were planned to be shared between the two Hanford detectors, will not be. Similarly, some installation fixtures will be retained at Hanford after the

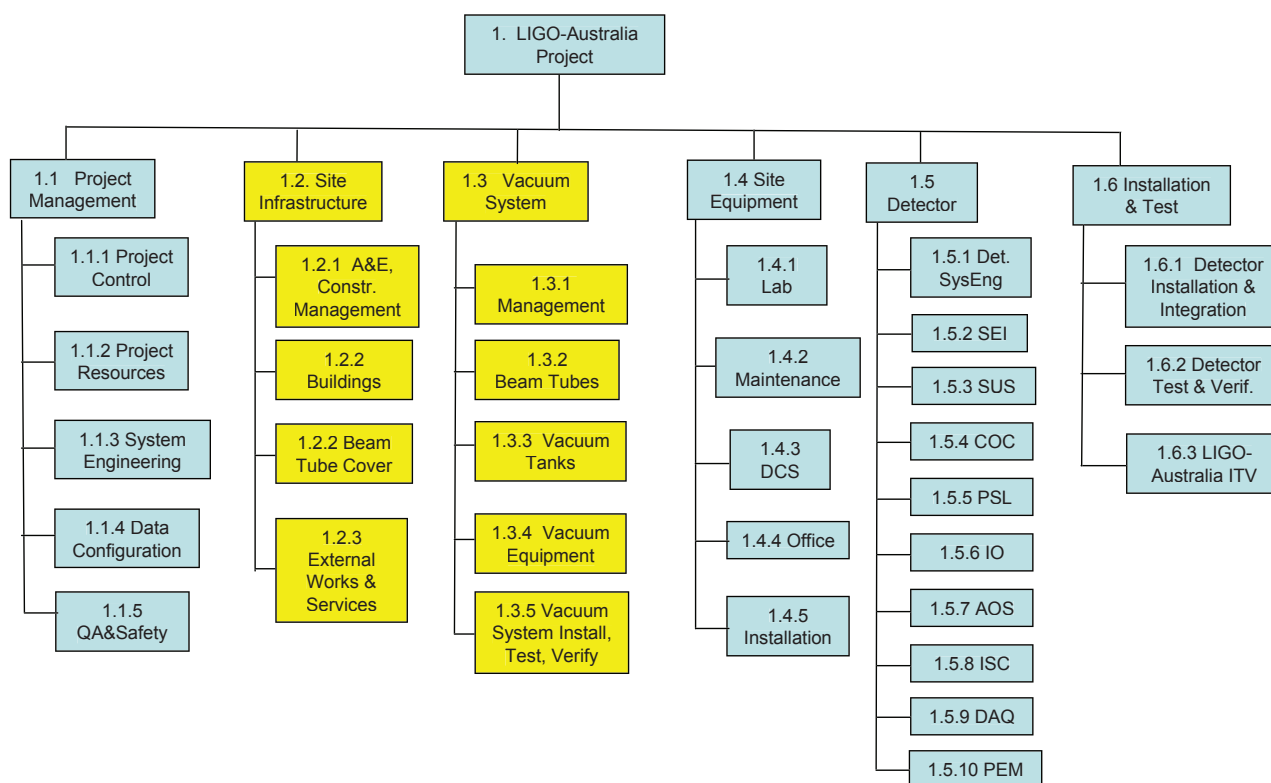

Figure 5.2 Work Breakdown Structure (WBS) for LIGO Australia. Elements shown in gray will be performed by LIGO-Australia project staff directly. Elements shown in yellow will be predominantly performed by major subcontractors working under the oversight of LIGO-Australia project staff.

completion of installation in case any removal of components and rework is required, and these items will need to be replicated by LIGO-Australia. LIGO-Australia is responsible for the cost of shipment to Australia and all the cost to assemble the components of each detector subsystem and to integrate these completed subsystems into the full detector. Using data supplied by LIGO, ACIGA has estimated the assembly, test and verification costs for these elements using local labour rates.

WBS1.6 Installation and Test covers the detector installation, integration, and test, operating in the overall facility. The Advanced LIGO cost estimate was used as a basis of estimate for this element, using Advanced LIGO hours and labour types, and Australian rates.

Contingency was included on each WBS element, as has been found to be essential on all state-of-the-art scientific facilities. Where contingency estimates were available from the corresponding Advanced LIGO cost estimate (reviewed and approved by NSF), the same percentages were applied to the LIGO-Australia estimate. For the site preparation and building construction, a contingency of 10% was used, as recommended by the quantity surveyor. For the vacuum system, the contingency used was 10%, based on the experience of the LIGO Laboratory during the construction of its vacuum systems. During project execution, contingency will be centrally managed by the project manager, using a Change Control Board, (CCB) in accordance with best project management practice.

Based on the above described estimation process, the total funds required by LIGO-Australia to construct an operating gravitational wave observatory using the LIGO-Australia detector will be AU\$140M. All costing was done in 2010 Australian dollars and if the project is funded, the budget will need to be adjusted to actual year dollars using standard escalation tables. This cost

estimate was reviewed by a team from LIGO who assessed its completeness and accuracy.

The required funding profile versus time is shown in Table 5.2. The first year costs cover site investigations and facility design. The major construction years are year 2-4 and it is during those years that the greatest costs are incurred. The final two years involve the effort to install and commission the US-supplied detector and the costs are correspondingly lower again.

Table 5.2 Funding requirement versus time

Year	Funding required (2010\$)
FY2011-2012	\$7M
FY2012-2013	\$37M
FY2013-2014	\$49M
FY2014-2015	\$33M
FY2015-2016	\$9M
FY2016-2017	\$4M
Total	\$140M

There is the possibility of significant international contributions to the construction of LIGO-Australia. The gravitational wave research communities in India and China have indicated that they would like to contribute personnel during construction; however, any such contribution will require new funding. At this time, we are supporting our colleagues in their attempts to secure funding from their respective governments and would use these contributions to augment the project and to reduce risk, but we have not counted them in the funding estimates. Government to government contacts will likely be important for securing such international contributions.

Table 5.1 Cost Estimate by Second Level WBS Element

WBS	Title	Labour	Equipment /Supplies	Other	Contingency	Total
1.1	Project management	\$7.6M		\$0.3M	\$0.8M	\$8.7M
1.2	Site Infrastructure	\$32.4M (Major Subcontracts)			\$3.2M	\$35.6M
1.3	Vacuum System	\$68.0M (Major Subcontracts)			\$6.8M	\$74.8M
1.4	Site Equipment	\$1.2M	\$4.1M	\$0.6M	\$1.1M	\$7.0M
1.5	Detector	\$3.5M	\$0.9M	\$0.7M	\$1.2M	\$6.3M
1.6	Installation & Test	\$5.3M		\$0.9M	\$1.4M	\$7.6M
1.0	Total					\$140.0M

Operations costs

Following the completion of facility construction in about 2015, site operations must begin, even while the final stages of detector installation and commissioning are occurring. Site operations will gradually ramp up, over the next two years and by 2017 will reach full scale with continuous, round-the-clock operation.

LIGO and NSF are seeking a 10 year commitment for operating costs, to ensure that the maximum value is accrued from their investment.

Operating costs were estimated using the existing operations of the two LIGO sites as a model. Based on actual experience from LIGO, and bearing in mind that this facility will operate around the clock, a dedicated team of operators, and resident scientists and engineers numbering about 25 full time people must be funded. Other costs (power, cryogenics, maintenance and other services) were estimated using local costs. The annual operating budget of the LIGO site is estimated to be ~ \$6M per year (2010 dollars). About 70% of the operations costs are staffing costs.

5.4 RISK MATRIX AND RISK MITIGATION

Table 5.3 on the following pages summarizes the most important risk areas and their consequences. The intrinsic level of risk is assessed for each one—by ‘intrinsic’ we mean the level of risk that would apply under average project conditions. The next column gives the specific mitigation activities which our collaboration has either done to date or plans for the future. The final column is our assessment of the final level of risk after these mitigation factors are taken into account. As an example, the extreme sensitivity of the measurements and the criticality of the design to achieve that sensitivity makes the intrinsic technical risk for detector performance ‘Very high’, but by using the LIGO hardware, with its decades of R&D, engineering and testing performed by the LIGO laboratory, as a mitigating factor, the overall risk is reduced to ‘Low’. It is this final column which should be evaluated to determine project feasibility.

The initial LIGO project was undoubtedly risky because it involved so much new technology. There were risks associated with vacuum, lasers, optics and vibration isolation. However, the experience gained by LIGO means that those risks will not be repeated. The close partnership with LIGO ensures rigorous project supervision, so that risks due to skills or poor planning are prevented.

Table 5.3 LIGO-Australia risk assessment

Risk Area	Risk description	Possible impact	Intrinsic risk level	Mitigation activities and strategies	Risk level with mitigation
Technical Performance					
Detector	Unforeseen noise source is encountered during commissioning of LIGO-Australia detector	<ul style="list-style-type: none"> Detector does not meet its sensitivity goals or requires longer for commissioning than planned 	Very high	<ul style="list-style-type: none"> Advanced LIGO technologies have been extensively tested and proven LIGO-Australia will be assembled after any problems encountered are solved during US installations 	Low
	Australian installation and commissioning staff inexperienced with Advanced LIGO design	<ul style="list-style-type: none"> Detector does not meet sensitivity requirements or schedule delays 	High	<ul style="list-style-type: none"> Attraction/retention of key scientists with LIGO or equivalent experience Training of LIGO-Australia staff during US installations 	Low
Vacuum System	Beamtube out-gassing is too high and beamtube fails to reach required pressure	<ul style="list-style-type: none"> Detector sensitivity is compromised 	High	<ul style="list-style-type: none"> LIGO-developed processing to reduce outgassing Careful monitoring of contractor to assure compliance with specs 	Low
	Improper materials or cleaning of in-vacuum components results in contamination of vacuum system	<ul style="list-style-type: none"> Detector degrades over time due to contamination on optics 	High	<ul style="list-style-type: none"> LIGO-developed specifications for materials and cleaning used LIGO staff to review procurement specifications for cleanliness specs 	Low-Moderate
	Critical mechanical or optical interfaces to detector incorrect	<ul style="list-style-type: none"> Cost increases and schedule delays to allow rework 	Moderate	<ul style="list-style-type: none"> Experienced LIGO staff to review procurement documents for correct interfaces specifications 	Low
Building and Site Development	Building foundation design amplifies seismic noise to unacceptable levels	<ul style="list-style-type: none"> Detector sensitivity is compromised at low frequencies 	Moderate	<ul style="list-style-type: none"> Use experienced and capable A&E firm for design Ensure requirements are understood 	Low
Scientific operations	Poor co-ordination between LIGO and LIGO-Australia operations decisions	<ul style="list-style-type: none"> Delays, reduced scientific observation time 	Moderate	<ul style="list-style-type: none"> Bilateral governance structures Teams have long experience working and communicating together 	Low
Schedule					
Scope creep	Schedule delays due to increases in scope and inclusion of new items into the design.	<ul style="list-style-type: none"> Delays in stage completion through insufficient documentation 	Moderate	<ul style="list-style-type: none"> Rigorous change control process imposed on all aspects of project 	Low
Climatic conditions/ Industrial conditions	Inclement weather or temperature extremes for specialised construction eg concrete pours	<ul style="list-style-type: none"> Schedule delays due to lost time Increased costs because other contractors are affected 	Moderate	<ul style="list-style-type: none"> Use realistic construction schedules with adequate contingency for unforeseen outside influences 	Low
	Delays through strikes, walk-offs and other industrial action				

Table 5.3 LIGO-Australia risk assessment

Risk Area	Risk description	Possible impact	Intrinsic risk level	Mitigation activities and strategies	Risk level with mitigation
Cost					
Cost overrun due to poor cost estimate or poor management	Cost estimate incomplete or incorrect	<ul style="list-style-type: none"> Insufficient funds to complete facility as required, impacting detector performance or project completion 	Moderate	<ul style="list-style-type: none"> Comparison with LIGO experience and costs for validation Reasonable contingency included in costs estimate for unexpected events or costs 	Low
	Scope creep and inclusion of new items into the design.	<ul style="list-style-type: none"> Extra costs from scope increase forces cut-backs in crucial areas 	High	<ul style="list-style-type: none"> Rigorous change control process imposed on all aspects of project 	Low
Currency exchange rates/ commodity prices	Currency exchange rate changes increase the cost of important components	<ul style="list-style-type: none"> Cost increases force descopeing of facility or requests for additional funds 	Moderate	<ul style="list-style-type: none"> Majority of project funds expended on Australian goods and service, not purchased abroad 	Low
	World commodity prices (particularly stainless steel) increase due to global demand	<ul style="list-style-type: none"> Cost increases force descopeing of facility or requests for additional funds 	High	<ul style="list-style-type: none"> Contingency for commodity price changes included 	Moderate

6 REFERENCES

1. Einstein, A, 1916. *Preuss. Akad. Wiss. Berlin, Sitzungsberichte der Physikalisch-mathematischen Klasse, Preuss. Akad. Wiss. Berlin, Sitzungsberichte der Physikalisch-mathematischen Klasse.*
2. Harry G. M. (for the LIGO Scientific Collaboration), 2010, "Advanced LIGO: the next generation of gravitational wave detector", *Classical and Quantum Gravity*, 27,084006
3. <http://www.aigo.org.au/>
4. Abramovici, A. et al.1992, "LIGO: the Laser Interferometer Gravitational-Wave Observatory, Science (USA), 256, 325.
5. Gertsenshtein, M. E., and Pustovoit, V. I, 1962, "On the detection of low frequency gravitational waves", *Soviet Physics – JETP*, 16, 433.
6. Meers, B. J., 1988, "Recycling in laser-interferometric gravitational-wave detectors", *Physics Review D*, 38, 2317.
7. <http://www.aei.mpg.de/hannover-en/66-contemporaryissues/home/index.html>
8. <http://www.aei.mpg.de/english/research/teams/laserinterferometry/index.html>
9. <http://www.acpo.csiro.au/>
10. Robertson, N A, et al, 2004, "Seismic isolation and suspension systems for Advanced LIGO". Page 81 of: Hough, J, and Sanders, G (eds), *Gravitational Wave and Particle Astrophysics Detectors*. Proc. SPIE, vol. 5500.
11. Zucker, M. E., and Whitcomb, S. E., 1996, "Measurement of Optical Path Fluctuations due to Residual Gas in the LIGO 40 Meter Interferometer". Pages 1434 of: *Proceedings of the Seventh Marcel Grossman Meeting on recent developments in theoretical and experimental general relativity, gravitation, and relativistic field theories.*
12. Barriga P. et al., 2010. "AIGO: a southern hemisphere detector for the worldwide array of ground-based interferometric gravitational wave detectors", *Classical and Quantum Gravity*, 27, 084005.
13. <http://www.zt.science.uwa.edu.au/>
14. Coward, D., Blair, D., Burman, R., and Zhao, C., 2003, "Vehicle-induced seismic effects at a gravitational wave observatory", *Review of Scientific Instruments*, 74, 4846
15. <http://www.cascina.virgo.infn.it/>
16. <http://www.ligo.org/>
17. Penzias, A.A., and Wilson, R.W., 1965, "A Measurement of Excess Antenna Temperature at 4080 Mc/s", *Astrophysical Journal*, 142, 419
18. Hewish, A., Bell, S.J., Pilkington, J.D.H., Scott, P.F., and Collins, R.A., 1968, "Observation of a Rapidly Pulsating Radio Source", *Nature*, 217, 709
19. Goldman, I., Aharonov, Y., Alexander, G., and Nussinov, S., 1988. "Implications of the supernova SN1987A neutrino signals", *Physics Review Letters*, 60, 1789
20. Hobbs, G., 2008, "Gravitational wave detection using high precision pulsar observations, *Classical and Quantum Gravity*, 25, 114032.
21. <http://www.skatelescope.org/>
22. <http://lisa.nasa.gov/>
23. Sathyaprakash, B.S., and Schutz, B. F., 2009, "Physics, Astrophysics and Cosmology with Gravitational Waves", *Living Reviews in Relativity*, 12, 2.
24. Hulse, R.A, and Taylor, J.H., 1975, "Discovery of a Pulsar in a Binary System", *Astrophysical Journal*, 196, L51.
25. Will, C. M., 2006, "The Confrontation between General Relativity and Experiment", *Living Reviews in Relativity*, 9, 3.
26. Pretorius, F. 2007, "Binary Black Hole Coalescence", in "Relativistic Objects in Compact Binaries: From Birth to Coalescence", edited by: Colpi et al., published by: Springer Verlag, Canopus Publishing Limited
27. Payne, D. J. B., and Melatos, A., 2006, "Frequency spectrum of gravitational radiation from global hydromagnetic oscillations of a magnetically confined mountain on an accreting neutron star", *Astrophysical Journal*, 641, 471
28. Abbott, B. et al., 2007, "Searches for periodic gravitational waves from unknown isolated sources and Scorpius X-1: Results from the second LIGO science run" *Physics Review D*, 76, 082001
29. Hayama, K, et al. 2008. Searches for gravitational waves associated with pulsar glitches using a coherent network algorithm. *Classical and Quantum Gravity*. 25, 184016.

30. <http://swift.gsfc.nasa.gov/docs/swift/swiftsc.html>
31. <http://www.sciops.esa.int/index.php?project=INTEGRAL&page=index>
32. <http://icecube.wisc.edu/>
33. Arnaud, N et al., 2004, "Detection of a close supernova gravitational wave burst in a network of interferometers, neutrino and optical detectors", *Astroparticle Physics*, 21, 201.
34. Abadie, J. et al., 2010, "Search for gravitational waves from compact binary coalescence in LIGO and Virgo data from S5 and VSR1", *Physics Reviews D*, 82,102001.
35. Nakar, E., 2007, "Short-hard gamma-ray bursts". *Physics Reports*, 442, 166
36. Blair D. G. et al., 2008, "The Science benefits and preliminary design of the southern hemisphere gravitational wave detector ALIGO", *Journal of Physics: Conference Series*, 122, 012001.
37. Maggiore, M., 2000, "Gravitational Wave Experiments and Early Universe Cosmology", *Physics Reports*, 331, 6.
38. LSC Virgo Collaboration, 2009, "An Upper Limit on the Amplitude of Stochastic Gravitational-Wave Background of Cosmological Origin", *Nature*, 460, 990.
39. Schutz, B. F., 1986, "Determining the Hubble Constant from Gravitational Wave Observations", *Nature*, 323, 310
40. Ott, C. D., 2009, "The gravitational-wave signature of core-collapse supernovae", *Classical and Quantum Gravity*, 26, 063001.
41. Woosley, S. E., MacFadyen, A. I., and Heger, A., 1999, "Collapsars, Gamma-Ray Bursts, and Supernovae". in: *Supernovae and Gamma-Ray Bursts*, eds. M. Livio, K. Sahu, & N. Panagia (Cambridge: Cambridge University Press)
42. Usov, V. V., 1992, "Millisecond pulsars with extremely strong magnetic fields as a cosmological source of gamma-ray bursts", *Nature*, 357, 472
43. Abbott, B. P. et al., 2009, "LIGO: the Laser Interferometer Gravitational-Wave Observatory", *Reports on Progress in Physics*, 72, 07690
44. Willke, B., 2010, "Stabilized lasers for advanced gravitational wave detectors", *Laser and Photonics Reviews*, 4, 780
45. Aidan F. Brooks, Thu-Lan Kelly, Peter J. Veitch, and Jesper Munch, "Ultra-sensitive wavefront measurement using a Hartmann sensor", *Opt. Express* 15, 10370-10375 (2007)
46. Abbott R. et al., 2002, "Seismic isolation for Advanced LIGO", *Classical and Quantum Gravity*, 19(7), 1591.
47. Buonanno, A., and Chen, Y. 2001, "Quantum noise in second generation, signal-recycled laser interferometric gravitational-wave detectors", *Physics Reviews D*, 64, 042006.
48. Vahlbruch, H. et al., 2006, "Coherent Control of Vacuum Squeezing in the Gravitational-Wave Detection Band", *Physical Reviews Letters*, 97, 011101.
49. K. McKenzie, N. Grosse, W. Bowen, S.E. Whitcomb, M.B. Gray, D.E. McClelland and P.K. Lam, "Squeezing in the audio gravitational-wave detection band", *Physical Review Letters*, 93, 161105.
50. Braginsky, V. B., Gorodetsky, M. L., and Khalili, F. Ya., 1997, "Optical bars in gravitational wave antennas", *Physics Letters. A*, 232, 340.
51. Buonanno, A., and Chen, Y., 2002, "Signal recycled laser-interferometer gravitational-wave detectors as optical springs", *Physical Review. D*, 65, 042001.
52. Chung, S. K., Wen, L., Blair, D., Cannon, K., and Datta, A., 2010, "Application of graphics processing units to search pipelines for gravitational waves from coalescing binaries of compact objects", *Classical and Quantum Gravity*, 27, 135009.
53. Hooper, S., Wen, L., Blair, D., Chung, S. K., Chen, Y., and Luan, J., 2010, "Low-Latency Detection of Gravitational Waves" Page 211 of: *American Institute of Physics Conference Series*, vol.1246.
54. <http://rsaa.anu.edu.au/skymapper/>
55. <http://www.seeproject.org.au/>

© 2011 The University of Western Australia

Published by:
The University of Western Australia
M013, 35 Stirling Highway
Crawley WA 6009

Tel: +61 (0) 8 6488 2460
Fax: +61 (0) 8 6488 7364
Email: dvcr@admin.uwa.edu.au
Web: www.gravity.uwa.edu.au

Designed and printed at UniPrint
Crawley, Western Australia