

LASER INTERFEROMETER GRAVITATIONAL WAVE OBSERVATORY
-LIGO-
CALIFORNIA INSTITUTE OF TECHNOLOGY
MASACHUSETTS INSTITUTE OF TECHNOLOGY

LIGO- E1101021-v1	3/26/12
AOS SLC ITM Elliptical Baffle Installation Procedure	
Michael Smith	

LIGO Hanford Observatory
P.O. Box 1970; Mail Stop S9-02
Richland, WA 99352
Phone (509) 37208106
Fax (509) 372-8137
E-mail: info@ligo.caltech.edu

LIGO Livingston Observatory
19100 LIGO Lane
Livingston, LA 70754
Phone (225) 686-3100
Fax (225) 686-7189
E-mail: info@ligo.caltech.edu

California Institute of Technology
LIGO – MS 18-34
Pasadena, CA 91125
Phone (626) 395-2129
Fax (626) 304-9834
E-mail: info@ligo.caltech.edu

Massachusetts Institute of Technology
LIGO – MS NW22-295
Cambridge, MA 01239
Phone (617) 253-4824
Fax (617) 253-7014
E-mail: info@ligo.mit.edu

Table of Contents

1 SCOPE3

1.1 ITM Elliptical Baffle 3

Table of Tables

No table of figures entries found.

Table of Figures

Figure 1: ITM Elliptical Baffle 4

Figure 2: Baffle & Beam Dump Suspension, Mounted to ISI Stage 0..... 5

Figure 3: Lift Fixture for Lifting Suspension Assy to the ISI Stage 0 Prior to Clamping .. 6

1 Scope

This document describes the assembly and installation procedures for the ITM Elliptical Baffle, FM Beam Dump, FM Elliptical Baffle, & Manifold Flat Baffle.

1.1 ITM Elliptical Baffle

The ITM Elliptical baffle assembly is shown in Figure 1.

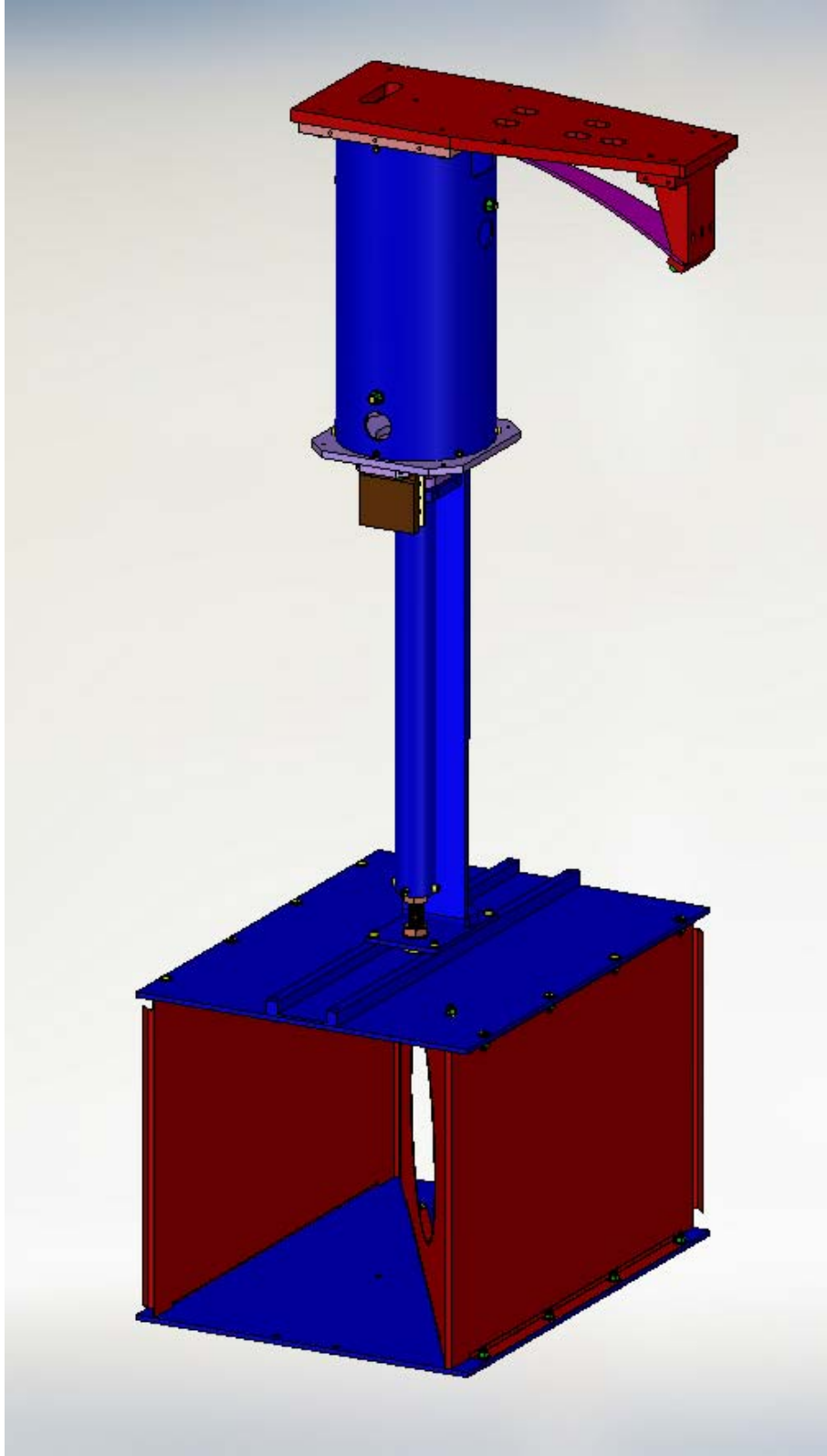

Figure 1: ITM Elliptical Baffle

The 44.3 lb ITM Elliptical Baffle is suspended from the ISI Stage 0 inside the BSC, as shown in Figure 2.

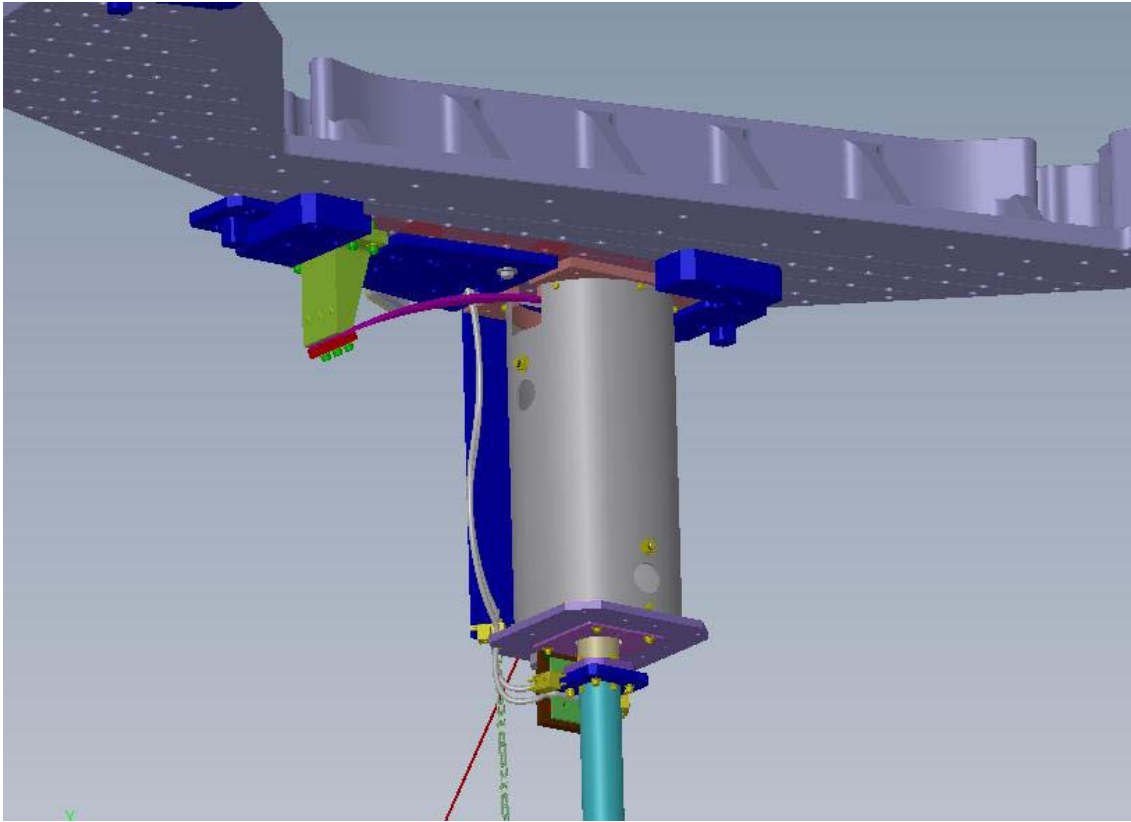

Figure 2: Baffle & Beam Dump Suspension, Mounted to ISI Stage 0

- 1 Prior to installing the suspension assembly, it will be assembled on a laboratory bench.
The vertical blade spring is attached to its mounting bracket and preloaded with approximately 45 lbs balance weight during the bench assembly of the suspension structure (SUS).
- 2 The 49 lb assembled SUS is then placed on top of the lift fixture, as shown in Figure 3, and lifted into place against the ISI Stage 0 by adjusting the telescoping leg length and by adjusting the height of the expanding scissors lift mechanism.

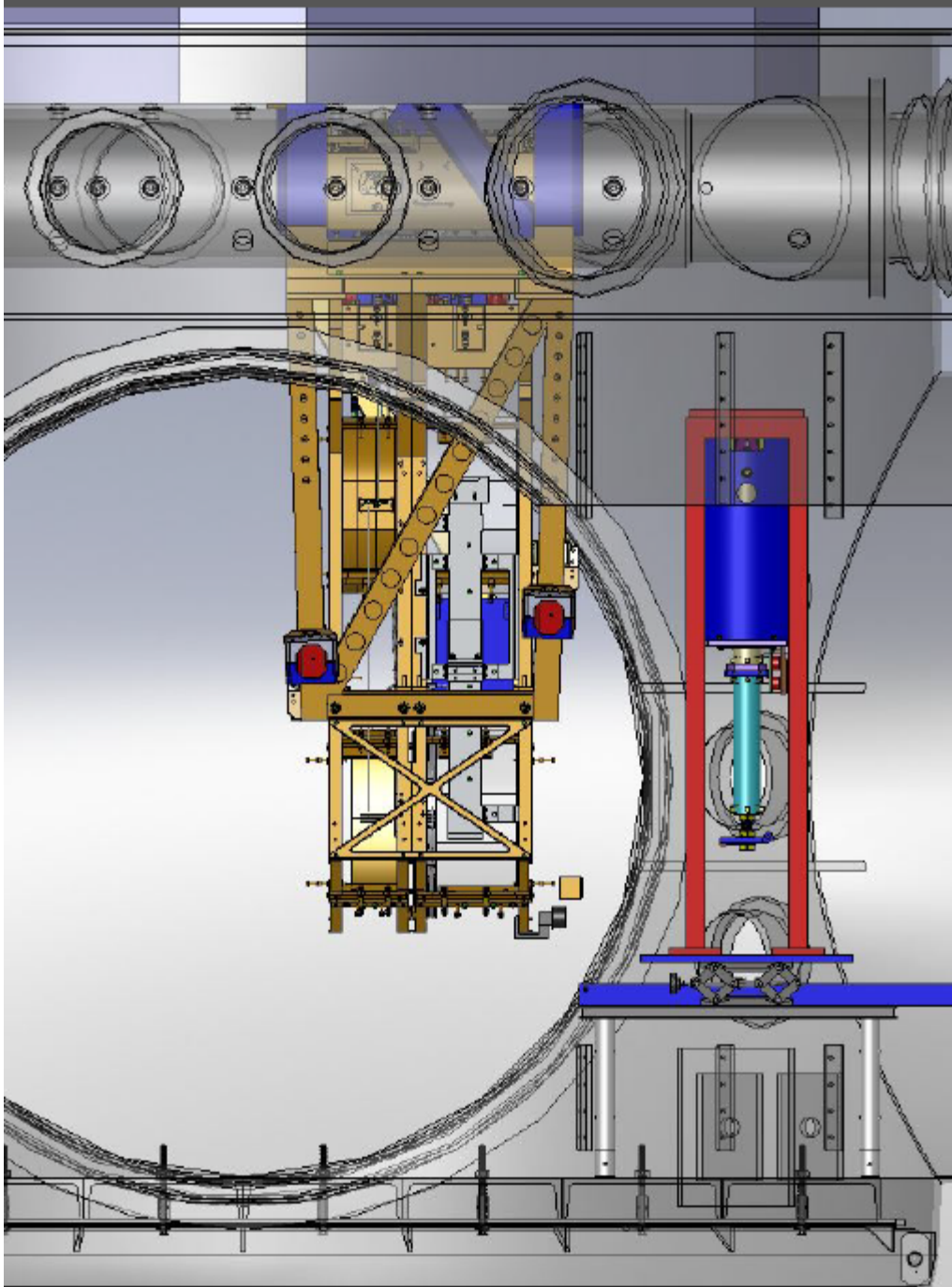

Figure 3: Lift Fixture for Lifting Suspension Assy to the ISI Stage 0 Prior to Clamping

- 3 The baffle suspension interface plate base will be held and positioned approximately in the final position by the temporary alignment clamps attached to Stage 0.

- 4 While the baffle suspension is held in place by the clamps, the vertical lift fixture will be removed.
- 5 The box structure of the baffle will be brought into the chamber and placed on top of the lift table, which will then be raised to bring the box structure in position to mount it to the bolt at the bottom of the suspension down tube.
- 6 While the baffle lateral position is being surveyed by an alignment theodolite, the baffle suspension will be slid laterally within the temporary alignment clamps until the baffle is positioned accurately on the beam center line as indicated with the theodolite. Then the interface plate will be rigidly clamped with appropriate dog-clamps to the Stage 0, using a torque wrench to tighten the dog-clamp bolts. The vertical alignment of the baffle is established by mechanical measurement from the bottom surface of the Stage 0