

NOTES CONTINUED:
1. APPROXIMATE WEIGHT= 39 LBS.

REV.	DATE	DCN #	DRAWING TREE #
v1	20 OCT 2011	D1100335-v4	-
v2	23 JAN 2012	-	-
-	-	-	-

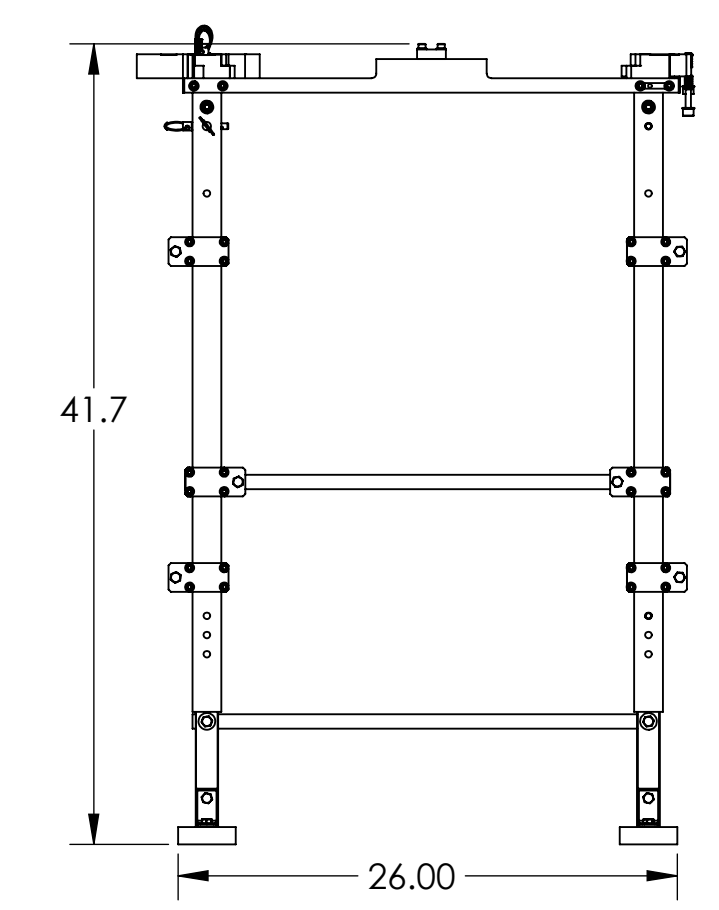
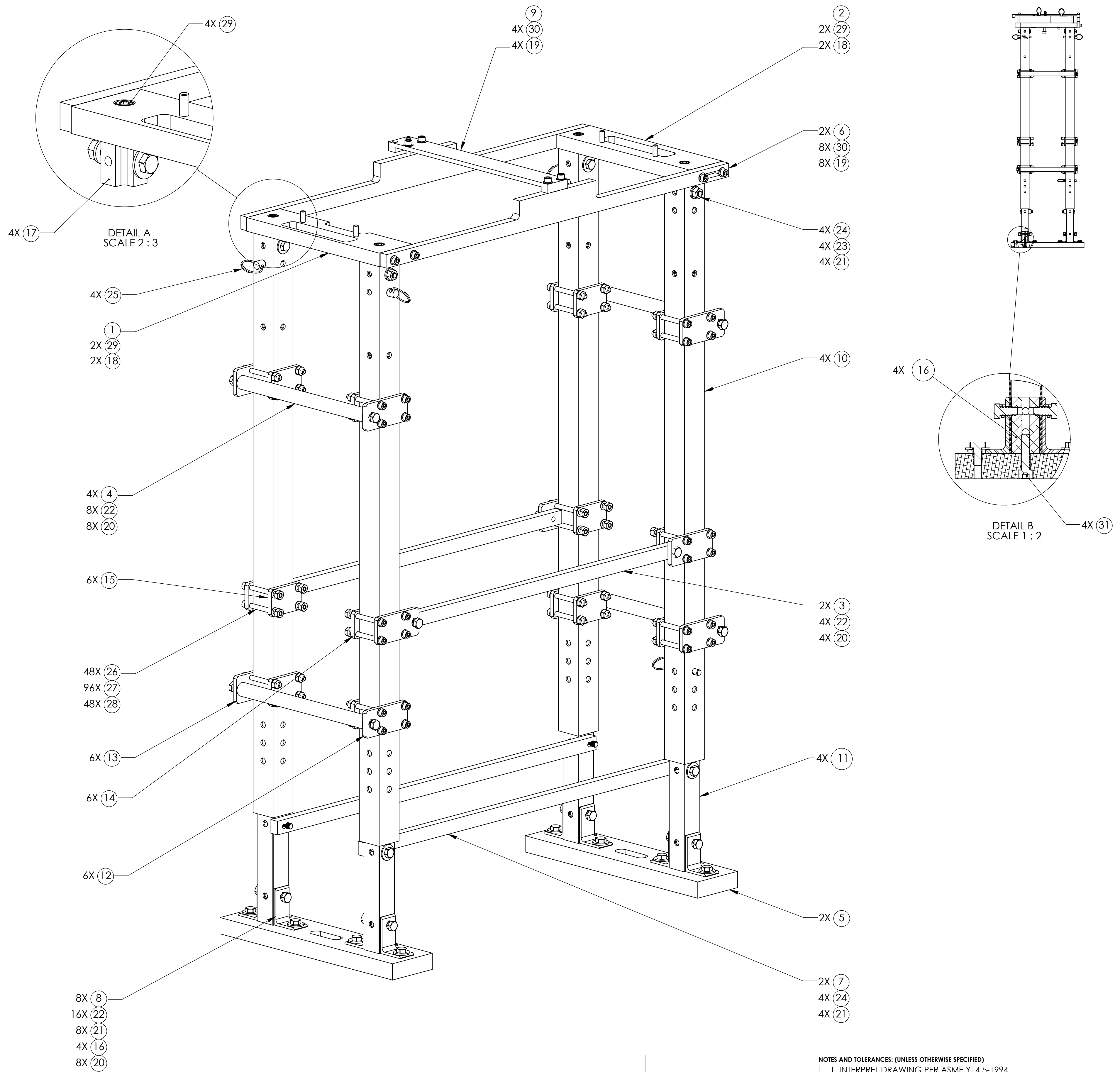

ITEM NO.	PART NUMBER	DESCRIPTION	MATERIAL	REQ	SPARE	TOTAL
31	92200A632	Socket Head Cap Screw_5/16-18 X 1.25 L	18-8 SSSL	4		4
30	92200A541	SOCKET HEAD CAP SCREW, SHC, 1/4-20 x 7/8" L	18-8 SSSL	12		12
29	92200A626	SOCKET HEAD CAP SCREW_5/16-18 X 3/4" L	18-8 SSSL	4		4
28	N-2520-A	HEX NUT 1/4-20	Ag-PLATED 300 SSSL	48		48
27	WF-25	FLAT WASHER 1/4 SCREW SIZE	18-8 SSSL	96		96
26	92185A555	Screw, socket head cap 1/4-20 X 2.5" L	316 SSSL	48		48
25	95165A054	QUICK-RELEASE PIN	18-8 SSSL	4		4
24	92245A591	SS HEX HEAD CAP SCREW-5/16-18, 2.0 L	18-8 SSSL	8		8
23	94758A029	FLANGE HEX NUT 5/16-18	18-8 SSSL	4		4
22	92245A580	HEX HEAD CAP SCREW-5/16-18 x 5/8 L	18-8 SSSL	28		28
21	98370A019	WASHER 5/16 SCREW	18-8 SSSL	16		16
20	98437A112	SPRING LOCK WASHER	18-8 SSSL	20		20
19	90313A203	FLAT WASHER 1/4 SCREW SIZE	18-8 SSSL	12		12
18	90145A542	1/4" DOWEL PIN	18-8 SSSL	4		4
17	D1102348	HIDDEN CONNECTOR	6061-T6 Al	4		4
16	D1102347	EXTENDED HIDDEN CONNECTOR	6061-T6 Al	4		4
15	D1102224-02	HANDLE TAB CLAMP	6061-T6 Al	6		6
14	D1102224-01	HANDLE TAB CLAMP	6061-T6 Al	6		6
13	D1102223-02	HANDLE TAB	6061-T6 Al	6		6
12	D1102223-01	HANDLE TAB	6061-T6 Al	6		6
11	D1102144-02	TELESCOPE TUBE FRAMING	6061-T6 Al	4		4
10	D1102144-01	TELESCOPE TUBE FRAMING	6061-T6 Al	4		4
9	D1102062	UPPER CLAMP	6061-T6 Al	1		1
8	D1102039	ANGLE CORNER BRACKET	6061-T6 Al	8		8
7	D1102038	LOWER SIDE BRACE	6061-T6 Al	2		2
6	D1102026	SIDE BEAM	6061-T6 Al	2		2
5	D1102024	FLOOR-MOUNTING BASE	6061-T6 Al	2		2
4	D1102023	ROUND BAR HANDLE	6061-T6 Al	4		4
3	D1102022	SIDE BRACE	6061-T6 Al	2		2
2	D1101972	DOG CLAMP SUPPORT	6061-T6 Al	1		1
1	D1101969	GUIDE BLOCK SUPPORT	6061-T6 Al	1		1

NOTES AND TOLERANCES: (UNLESS OTHERWISE SPECIFIED)	
1. INTERPRET DRAWING PER ASME Y14.5-1994.	
2. REMOVE ALL SHARP EDGES, .005-.015, FOR MACHINED PARTS. ROUND ALL EDGES APPROXIMATELY R.02 FOR SHEET METAL PARTS.	
3. DO NOT SCALE FROM DRAWING.	
4. ALL MACHINING FLUIDS MUST BE FULLY SYNTHETIC, FULLY WATER SOLUBLE AND FREE OF SULFUR, SILICONE, AND CHLORINE.	
DIMENSIONS ARE IN INCHES	
TOLERANCES:	
.XX ± .06	
.XXX ± .010	
ANGULAR ± 1.0°	
MATERIAL	N/A
FINISH	N/A μinch

LIGO CALIFORNIA INSTITUTE OF TECHNOLOGY
MASSACHUSETTS INSTITUTE OF TECHNOLOGY

ADVANCED LIGO SUB-SYSTEM **AOS**

PART NAME
ACB_INSTALLATION LIFT STAND BSC5-7-8-10

DESIGNER	TQ. NGUYEN	12 OCT 2011	SIZE	DWG. NO.	REV.
DRAFTER	TQ. NGUYEN	18 OCT 2011			
CHECKER	L. AUSTIN	23 JAN 2012			
APPROVAL	C. TORRIE	23 JAN 2012	SCALE: 1:6	PROJECTION:	SHEET 1 OF 3

D **D1101957** **v2**

D1101957_Am Conolly Beffle Installation Stand PART PDM REV: X-085 DRAWING PDM REV: X-027

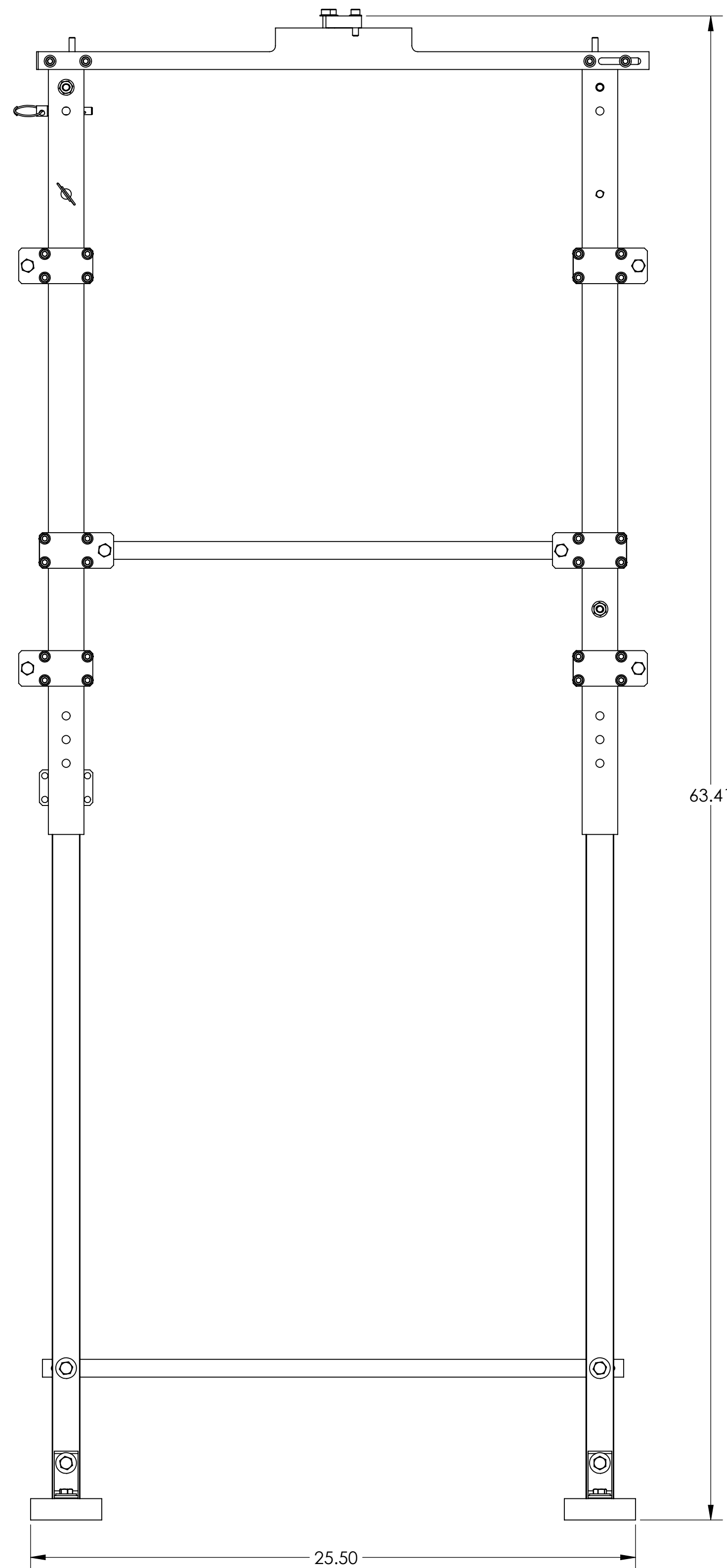
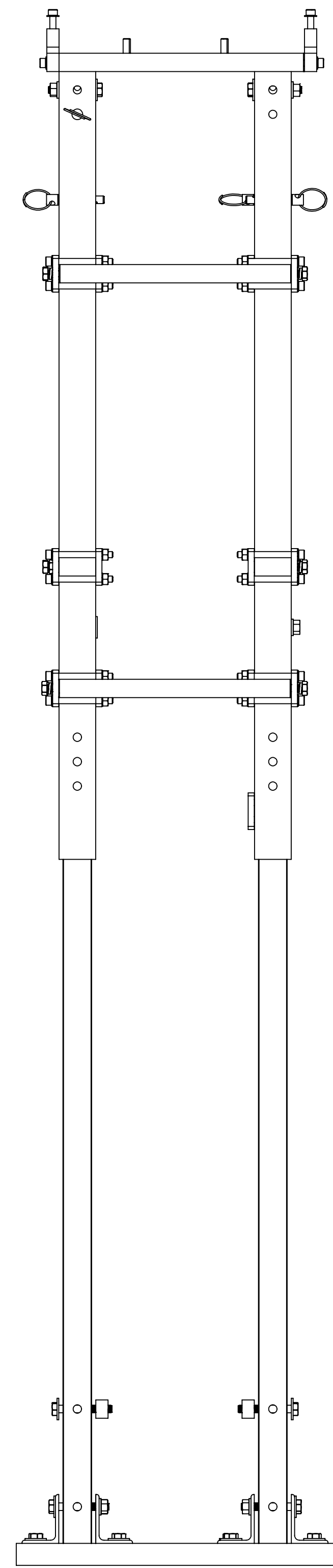

ACB_INSTALLATION STAND_EXTENDED VERSION

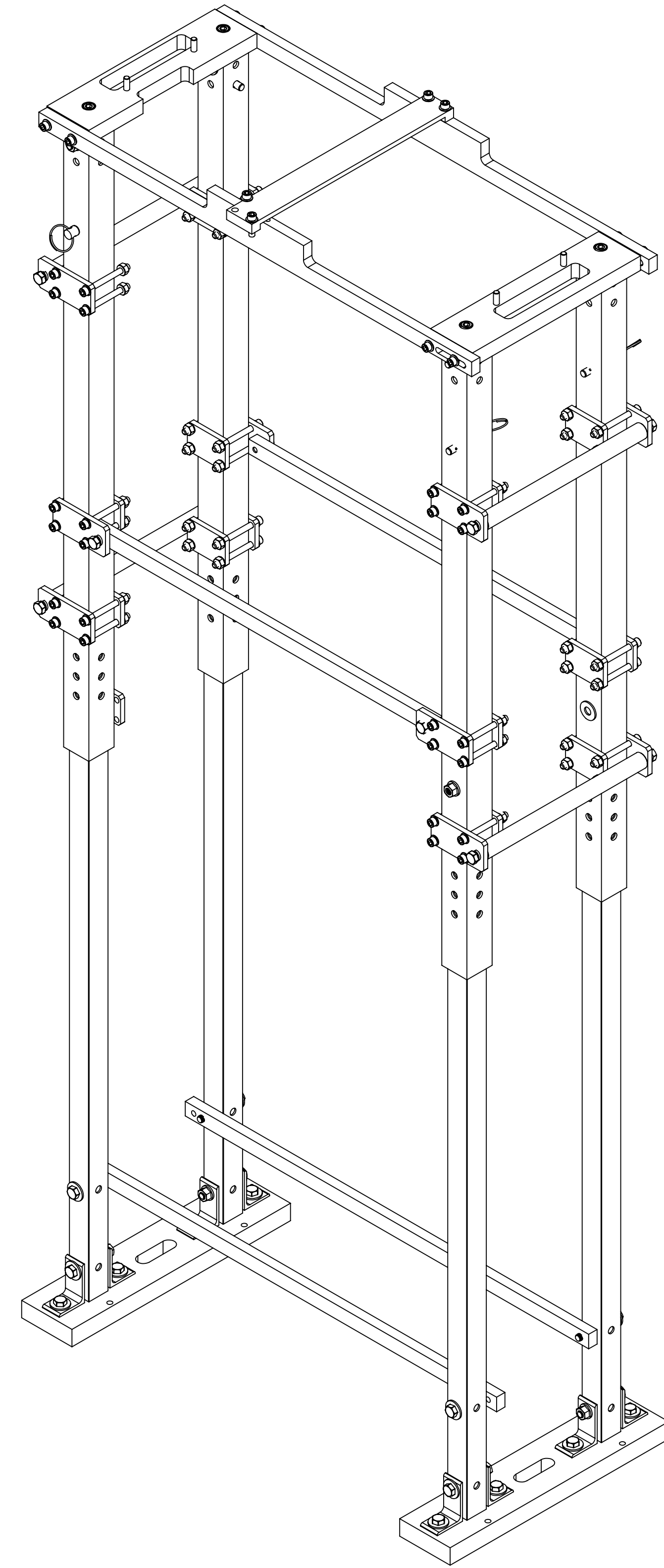

 CALIFORNIA INSTITUTE OF TECHNOLOGY MASSACHUSETTS INSTITUTE OF TECHNOLOGY		REV.
SIZE	DWG. NO.	REV.
D	D1101957	v2
SCALE: 1:6	PROJECTION:	SHEET 2 OF 3

D1101957_Arm Conolly Beffle Installation Stand PART PDM REV. X-012 DRAWING PDM REV. X-027

8

7

6

5

4

3

2

1

H

G

F

E

D

C

B

A

H

G

F

E

D

C

B

A

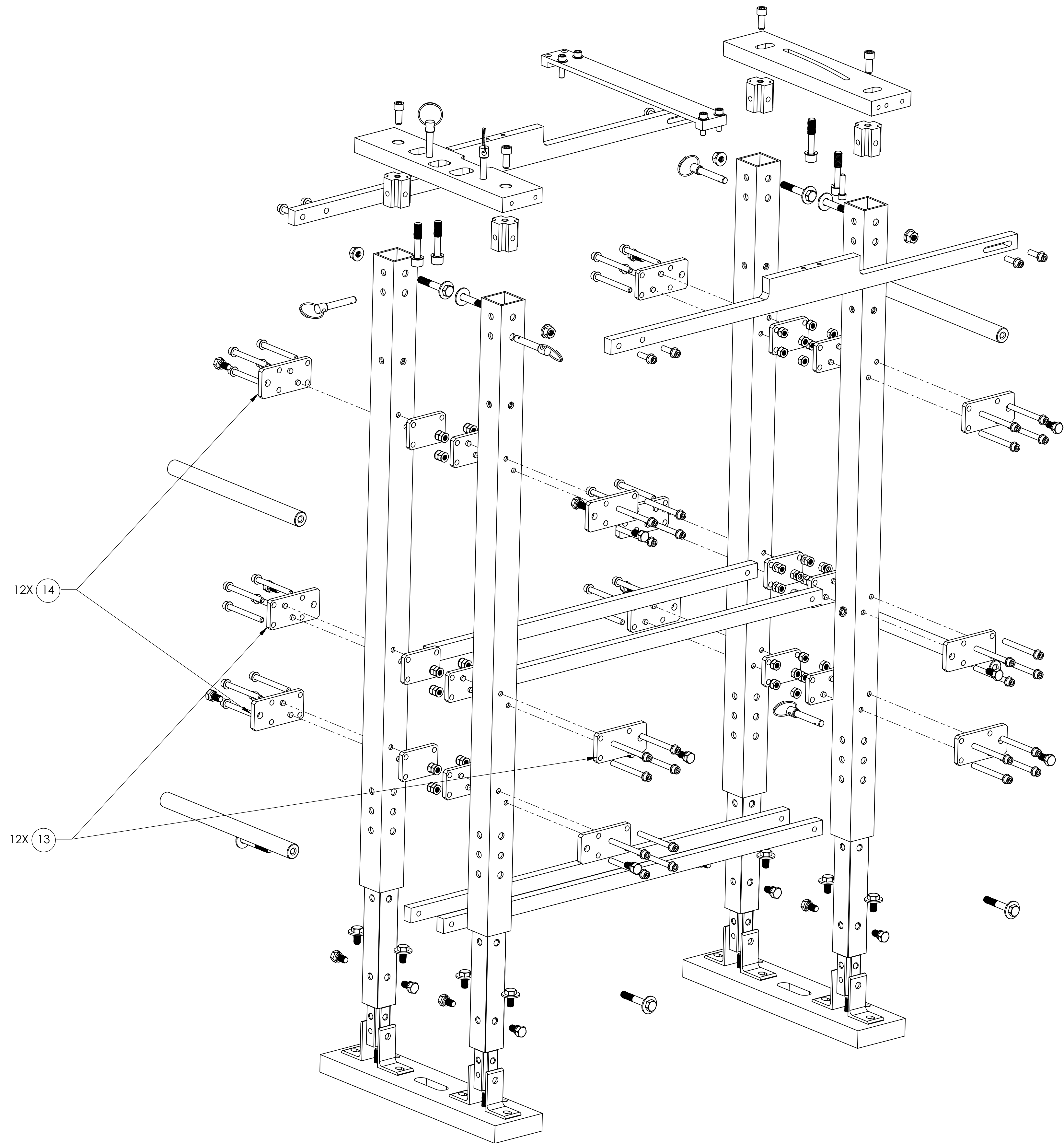

 CALIFORNIA INSTITUTE OF TECHNOLOGY MASSACHUSETTS INSTITUTE OF TECHNOLOGY		REV.
SIZE	DWG. NO.	REV.
D	D1101957	v2
SCALE: 1:3	PROJECTION:	SHEET 3 OF 3

D1101957_Arm Coevly Beffle Installation Stand PART PDM REV. X-085 DRAWING PDM REV. X-027