

BCHG7CBHBI 98.  
 G7F69Z9B; F5J9ZCFA 97 <5B75@MG5A DIBC B?G  
 CF8M9L8F5K B; D5FHBI A 69F 5B8 F9J 6CB CB  
 BCH8 G F: 579: C@C K 98 CB H-9B9LH@B96M5  
 H-F998 = #G9F 5@BI A 69F \*G9F 5@BI A 69FG6FH5H  
 \$\$%: CF H-9: #GH5FH7 @95B8 DFC 7 998  
 7 C BG97 I HJ 9@M I G9 "\$+ < < 7 < 5F57 HFG  
 9L5A D@9. 8LLLLLLL IJ MGB \$\$\$  
 5 J -6F5HC FMHC C @A 5M691 G98"

F9J "	85H9	87B:	8F5K B; HF99,
J %	- #&/#98%	998/\$\$, - *	!
!	!	!	!
!	!	!	!

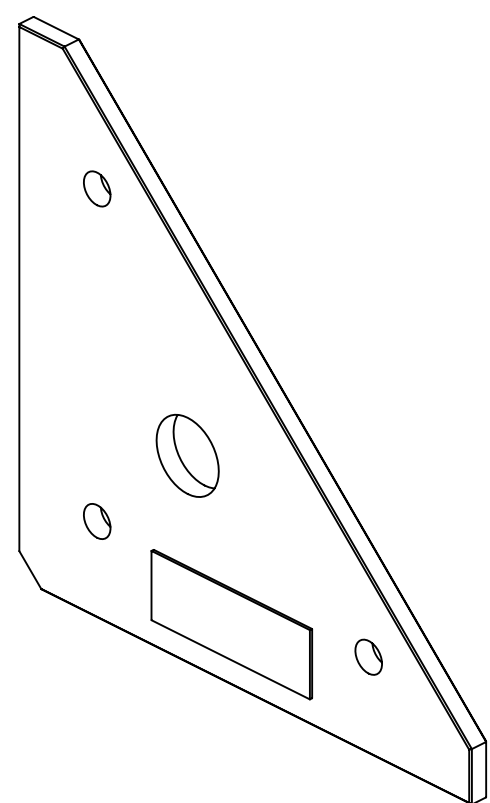
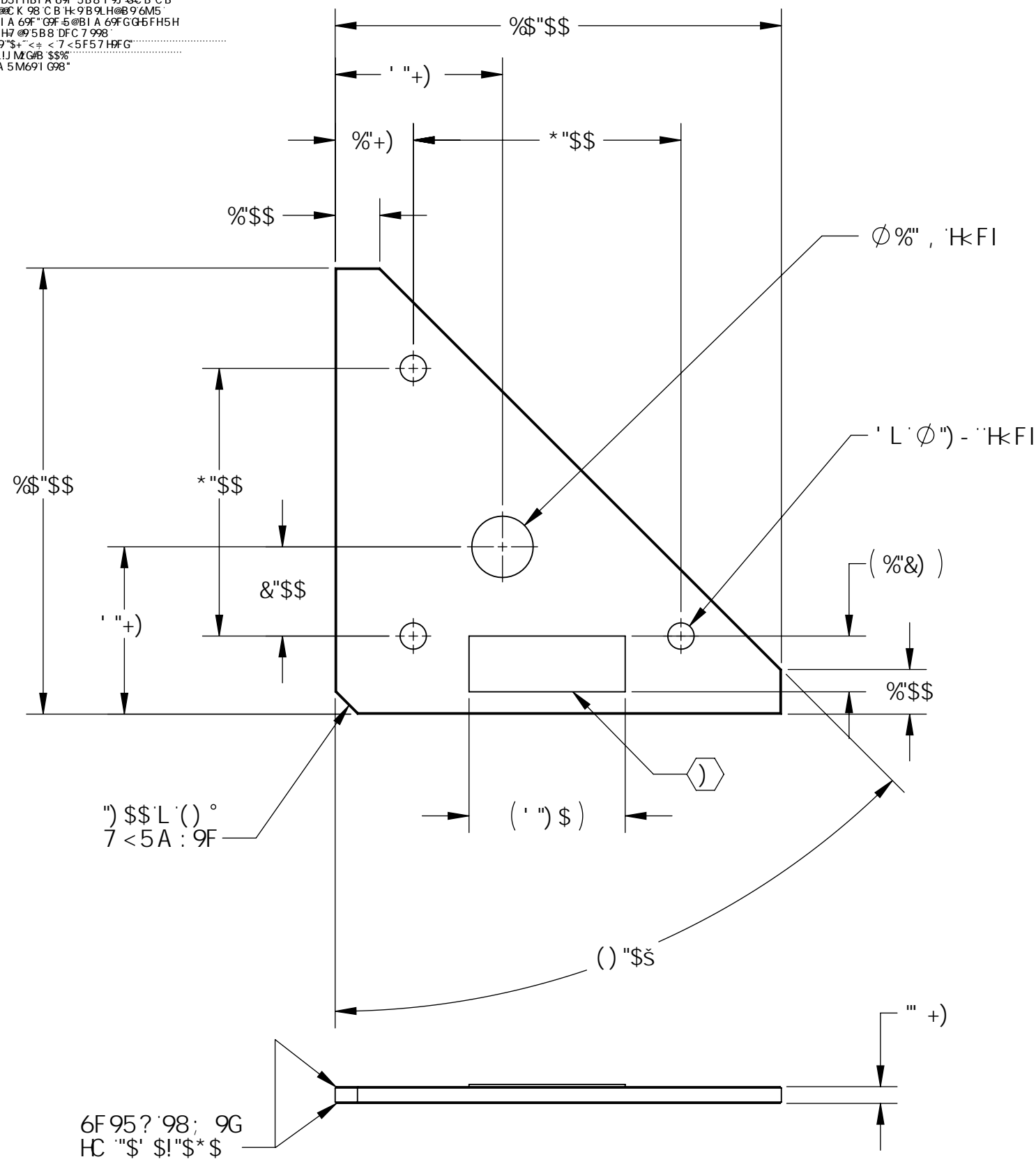

€C J =K

8%8% & (U@ C C DH7 5@9J 9FG; #5::97 @A D'D@5H9D5FHDBA F9J. LI.\$%8F5K B; D8A F9J. LI.\$%

BCHG5B8TC@F5B79G TI B@GGCH:9FK 497097 = 98L		LIGO 75@CFB5-BGHH H9C: H97 <BC@; M D5FH85A 9	
8A 9BGC BG5F9 B B7 <9G	% B HFD 9H8F5K B; D9F 5GA 9MK( ) 1% - ( " &" F9A C J 95@G: 5FD 98; 9QF "\$&A B"	A 5GG57 <I G9HG-BG-H H9C: H97 <BC@; M	U@= C 'C DH7 5@9J 9FG; #5::97 @A D'D@5H9
HC@F5B7 9G	" "8C BCHG7 5@9: FCA 8F5K B; "	89G: B9F 9>5A 9G -#% #9%	G99 8K; "BC"
TL ± '\$%	("5@A 57 <B-B; : @ -BGG<5@69K 5H9F GC @ 6@95B8: F99C: G @ I FZ	8F5: H9F =FCA 9FC -#85#98%	6 8 %/\$% & ( J %
L LL ± '\$\$)	7 <@CF B95B8 G@7 CB9ZG 7 < 5G7 B7 BB5HA @57 FCB 67 A H97 < (%\$"	7 < 97? 9F	
5B: I @F ± '\$%	A 5H9F-5@	5DDFCJ 5@ 9>5A 9G -#8%#9%	G7 5@9. %% DFC >97 HCB. G<99H9C: %
	5 €= \$( %&, σjWk		