

8

7

6

5

4

3

2

1

NOTES CONTINUED:

5. SCRIBE, ENGRAVE (A VIBRATORY TOOL MAY BE USED), LASER MARK OR MECHANICALLY STAMP (NO INKS OR DYES) DRAWING PART NUMBER, REVISION (AND VARIANT OR "TYPE" IF APPLICABLE) ON NOTED SURFACE OF PART FOLLOWED ON THE NEXT LINE WITH A THREE DIGIT SERIAL NUMBER. SERIAL NUMBERS START AT 001 FOR THE FIRST ARTICLE AND PROCEED CONSECUTIVELY. USE MINIMUM 0.12" HIGH CHARACTERS, UNLESS THE SIZE OF THE PART DICTATES SMALLER CHARACTERS. EXAMPLE: DXXXXXX-VY, TYPE-XX, S/N XXX

6. APPROXIMATE WEIGHT = X.XXX LB.

7. ALL PARTS SHALL BE MANUFACTURED IN ACCORDANCE WITH LIGO SPECIFICATION E0900364.

2X ϕ .20 ∇ .65
1/4-20 UNC - 2B ∇ .50
 \surd ϕ .30 X 120°, NEAR SIDE

2X ϕ .20 ∇ .65
1/4-20 UNC - 2B ∇ .50
 \surd ϕ .30 X 120°, NEAR SIDE

REV.	DATE	DCN #	DRAWING TREE #
-	-	-	-
-	-	-	-
-	-	-	-

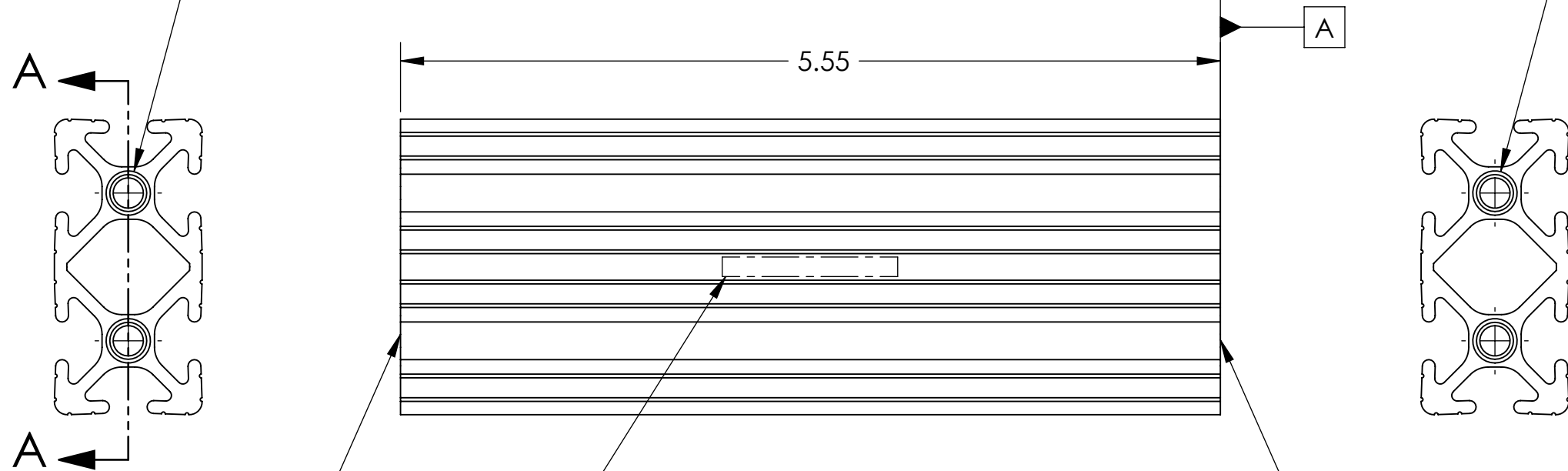

\surd .004 A

5

\surd .004



SECTION A-A

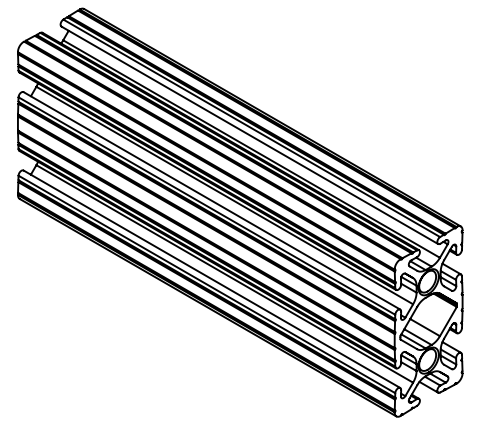

MATERIAL: McMaster 47065T213 (24" LENGTH, SHARE WITH D1101706)

D1101705 Vertical Mount, Eddie current damper, UIM Tooling, aLIGO, PART PDM REV.: DRAWING PDM REV:

NOTES AND TOLERANCES: (UNLESS OTHERWISE SPECIFIED)				LIGO		CALIFORNIA INSTITUTE OF TECHNOLOGY		MASSACHUSETTS INSTITUTE OF TECHNOLOGY		PART NAME	
DIMENSIONS ARE IN INCHES				ADVANCED LIGO		SUB-SYSTEM		SUS		Vertical Mount, Eddie current damper, UIM Tooling, aLIGO, McMaster 47065T213	
TOLERANCES: .XX ± .01 .XXX ± .005				MATERIAL		FINISH		NEXT ASSY		DESIGNER	
ANGULAR ± 0.5°				6061-T6 Al		125 μ inch		D1101702		SBARNUM 25 AUG 2011	
										DRAFTER	
										SBARNUM 26 AUG 2011	
										CHECKER	
										SBARNUM 26 AUG 2011	
										APPROVAL	
										MBARTON 26 AUG 2011	
										SIZE DWG. NO.	
										B D1101705	
										REV.	
										v1	
										SCALE: 1:1	
										PROJECTION:	
										SHEET 1 OF 1	

8

7

6

5

4

3

2

1