

**NOTES CONTINUED:**

- 5. APPROXIMATE WEIGHT = 21.6 LBS.
- 6. ASSEMBLE IN ACCORDANCE WITH SPECIFICATION E1100484.

REV.	DATE	DCN #	DRAWING TREE #
v1	21 NOV 2011	E1100478-v4	-
v2	13 MAR 2012	E1100478-v4	-
-	-	-	-

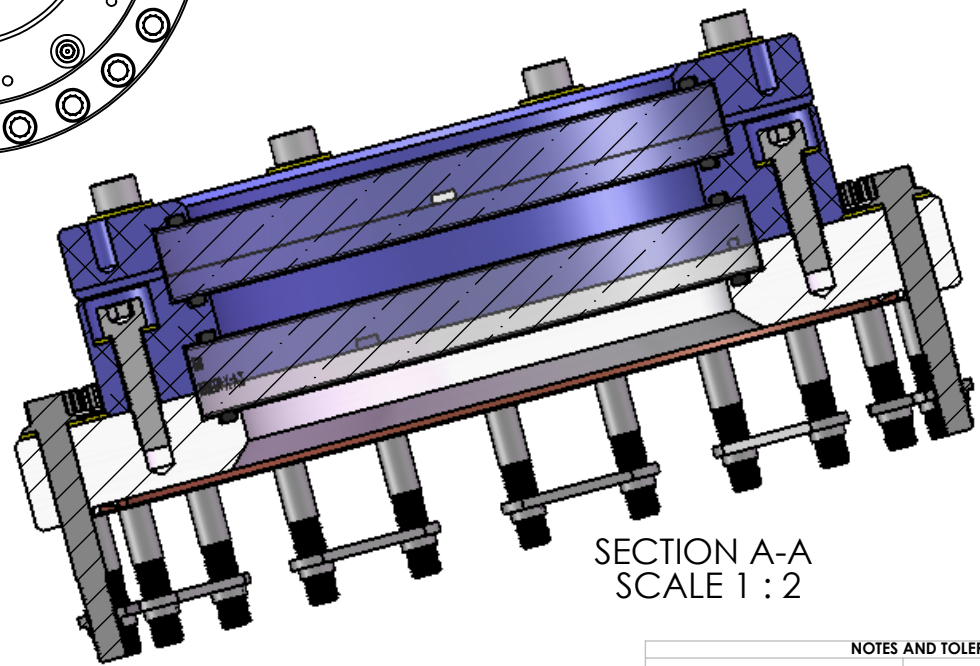
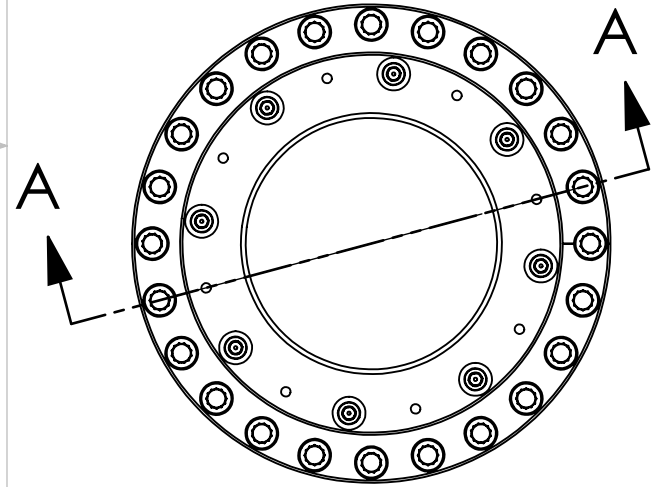
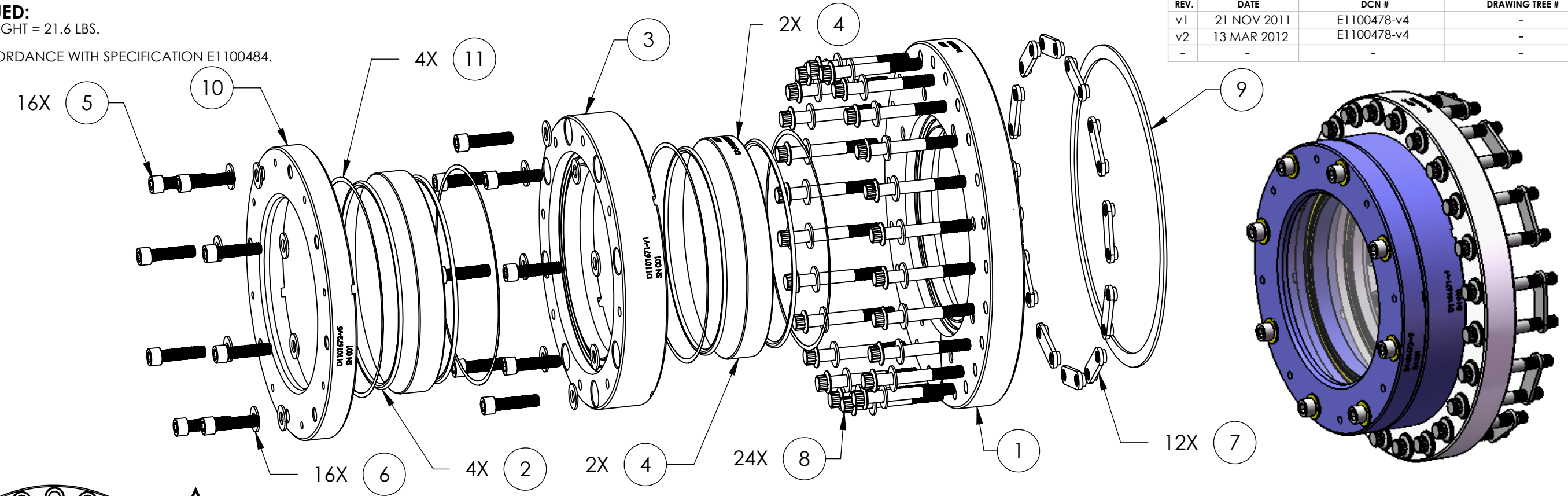

SECTION A-A  
SCALE 1 : 2

ITEM NO.	PART NUMBER	REQ
1	D1101001 aLIGO, high quality, 6in Viewport Flange	1
2	Parker O-Ring #2-253 Viton(R) Fluorocarbon (KFM), 75 shore A or equivalent. O-Rings must match-must be from the same lot/batch.	4
3	D1101671 aLIGO, High Power, Non Wedged 6in Viewport Clamp	1
4	D1101006-1 aLIGO, High quality, non-wedged, 6in Viewport, Optic AR1064/532	2
5	5/16-24 UNF x 1.25", Silver Plated, UC Components #C-3120-NA (or Equivalent)	16
6	5/16" FLAT WASHER, NAS 11149-C0563R ( or Equivalent)	16
7	Nut Plate, 10" Conflat, Nor-Cal NP-800 or equivalent	12
8	5/16-24 UNF x 2.5", Silver Plated, 12 PT Flange Bolt, and Washers MDC Kit #190067 (qty 25) or equivalent, discard nut.	24
9	Copper Gasket, 10" Conflat, MDC #191019 or equivalent	1
10	D1101672 aLIGO high power, non-wedged 6in Coverglass Clamp	1
11	D1003207 aLIGO, high quality, 6in viewport, Viewport Spacer	4

**NOTES AND TOLERANCES: (UNLESS OTHERWISE SPECIFIED)**

DIMENSIONS ARE IN INCHES  
TOLERANCES:  
.XX ± .03  
.XXX ± .010  
ANGULAR ± 1.0°

1. INTERPRET DRAWING PER ASME Y14.5-1994.  
2. REMOVE ALL SHARP EDGES, .005-.015, FOR MACHINED PARTS. ROUND ALL EDGES APPROXIMATELY R.02 FOR SHEET METAL PARTS.  
3. DO NOT SCALE FROM DRAWINGS.  
4. ALL MACHINING FLUIDS MUST BE FULLY SYNTHETIC, FULLY WATER SOLUBLE AND FREE OF SULFUR, SILICONE, AND CHLORINE.

MATERIAL 6061 FINISH 63 μinch

**LIGO** UNIVERSITY OF FLORIDA CALIFORNIA INSTITUTE OF TECHNOLOGY MASSACHUSETTS INSTITUTE OF TECHNOLOGY  
SYSTEM ADVANCED LIGO SUB-SYSTEM 100  
NEXT ASSY

PART NAME High Power, Non Wedged 6in Viewport Assy with Coverglass\_AR1064/532  
DESIGNER J. GLEASON 23 AUG 2011  
DRAFTER D. NANDA KUMARI NOV 2011  
CHECKER M. SMITH 9 DEC 2011  
APPROVAL

SIZE DWG. NO. B D1101670  
REV. v2  
SCALE: 1:8 PROJECTION: SHEET 1 OF 1

D1101670 ALIGO HIGH POWER NON WEDGED 6IN VIEWPORT ASSY, PART PDM REV: X-009, DRAWING PDM REV: X-013