

Overview of the projects at Caltech 40-m prototype

Koji Arai, Rana Adhikari, Joseph Betzwieser, Aidan Brooks, Jenne Driggers, Suresh Doravari, Kiwamu Izumi*, Jameson Graef Rollins, Steve Vass
LIGO Laboratory, California Institute of Technology, *Department of Astronomy, University of Tokyo, LIGO-G1100805



Abstract

The 40-meter prototype laser interferometer, located on the Caltech campus, is recently upgraded to increase its resemblance to Advanced LIGO interferometers so that it may be used for testing new interferometer technologies. Main targets currently pursued are lock acquisition and longitudinal sensing/control of the dual-recycled Fabry-Perot Michelson interferometer. We are also building simulated plants for rapid commissioning and adaptive filters for seismic noise cancellation. The current configuration of the detector and the status are discussed in this poster.

Current targets of the 40m prototype

Mission: Promote and accelerate commissioning of aLIGO

- The 40m is a control prototype of the aLIGO IFOs

Two main thrust areas are:

- Optical configuration
- Control issues of the IFO

Relationships between individual activities highlighted in this poster are summarized in this figure

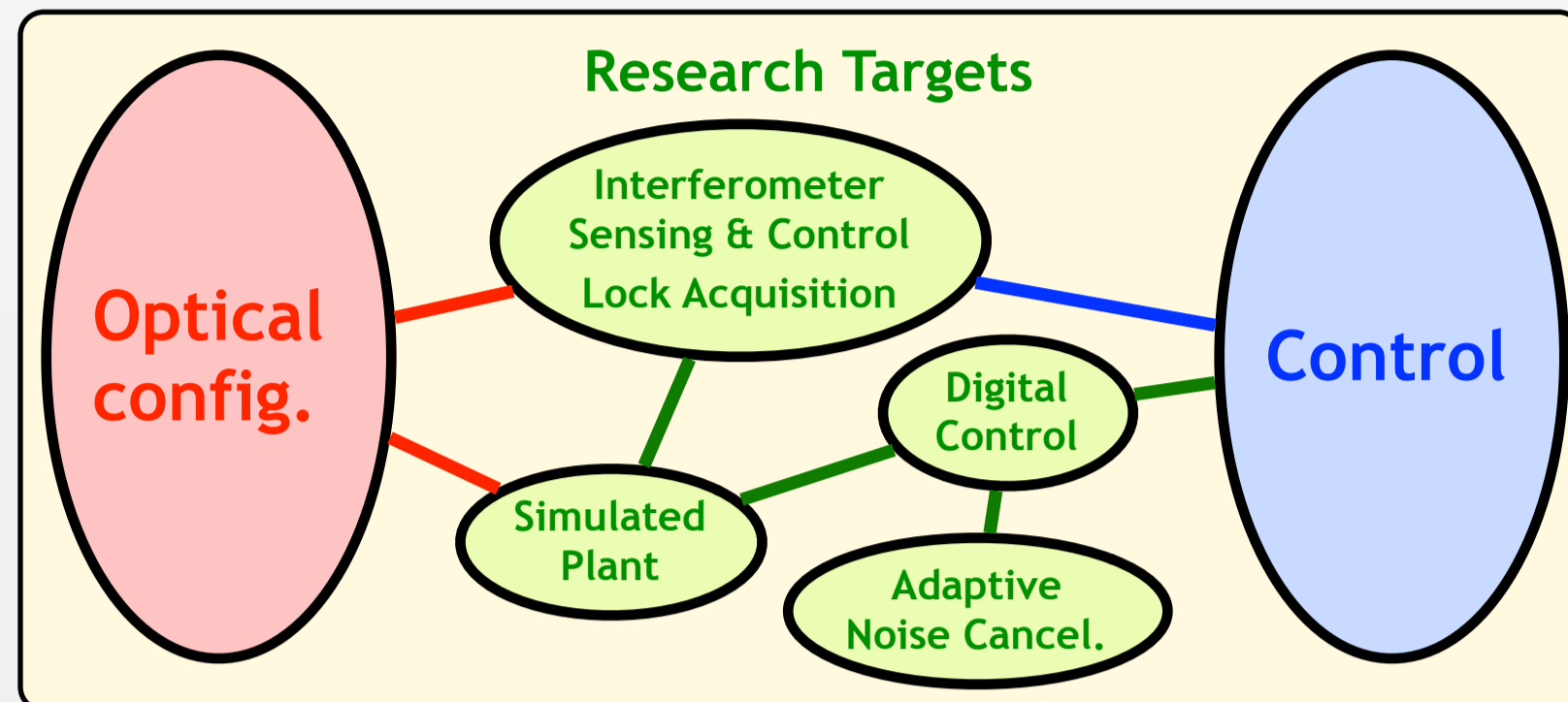

Optical configuration

Dual recycled Michelson with Fabry-Perot arms

- Upgrade installation completed in Dec. 2010

Dichroic ITM/ETM for Arm Length Stabilization using 532nm beams

Mimicking aLIGO : $F(1064\text{nm}) \approx 450$, $F(532\text{nm}) \approx 100$

Small Schnupp asymmetry: $\Delta l \approx 3\text{cm}$

Similar to the aLIGO's 5cm

Adjusted such that the 55MHz sidebands reach the dark port

Longer power and signal recycling cavities (PRC, SRC)

PRC = 6.8m, SRC = 5.4m, folded by ANU Tip-Tilt suspensions

Smaller test masses with SOS suspensions

3 inch dia. x 1 inch thick.

Same DC radiation pressure effect as that of aLIGO

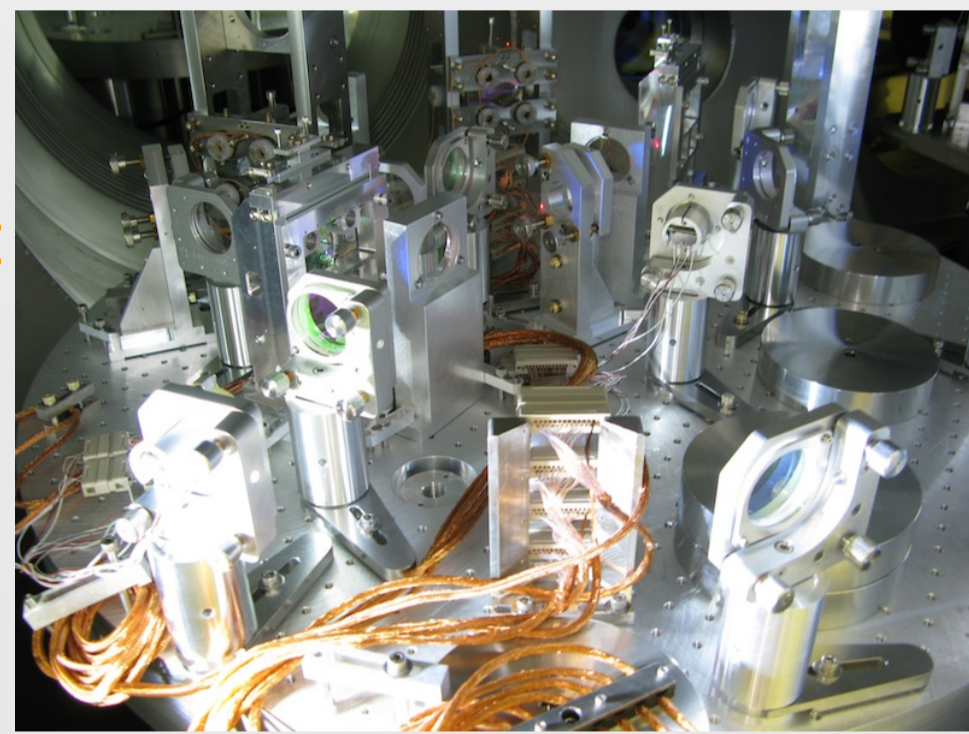

Interferometer sensing and control

Two modulations and demodulations at harmonic frequencies

- 11MHz and 55MHz modulation sidebands

The new RF system for the main interferometer involves modulation at 11MHz and 55MHz. The 11MHz sidebands resonate in the PRC while the 55MHz ones do in both the PRC and SRC. This difference enable us to separate the PRC, SRC, and Michelson length changes.

- Harmonic demodulation

In addition to the conventional demodulation, the 2nd and 3rd harmonic demodulations are used. The signals obtained by the 3rd harmonic demodulation are useful in the initial lock acquisition stages as they have inherent separation from the arm length signals.

The 2nd harmonic demodulation is used for the sideband power monitors in the PRC.

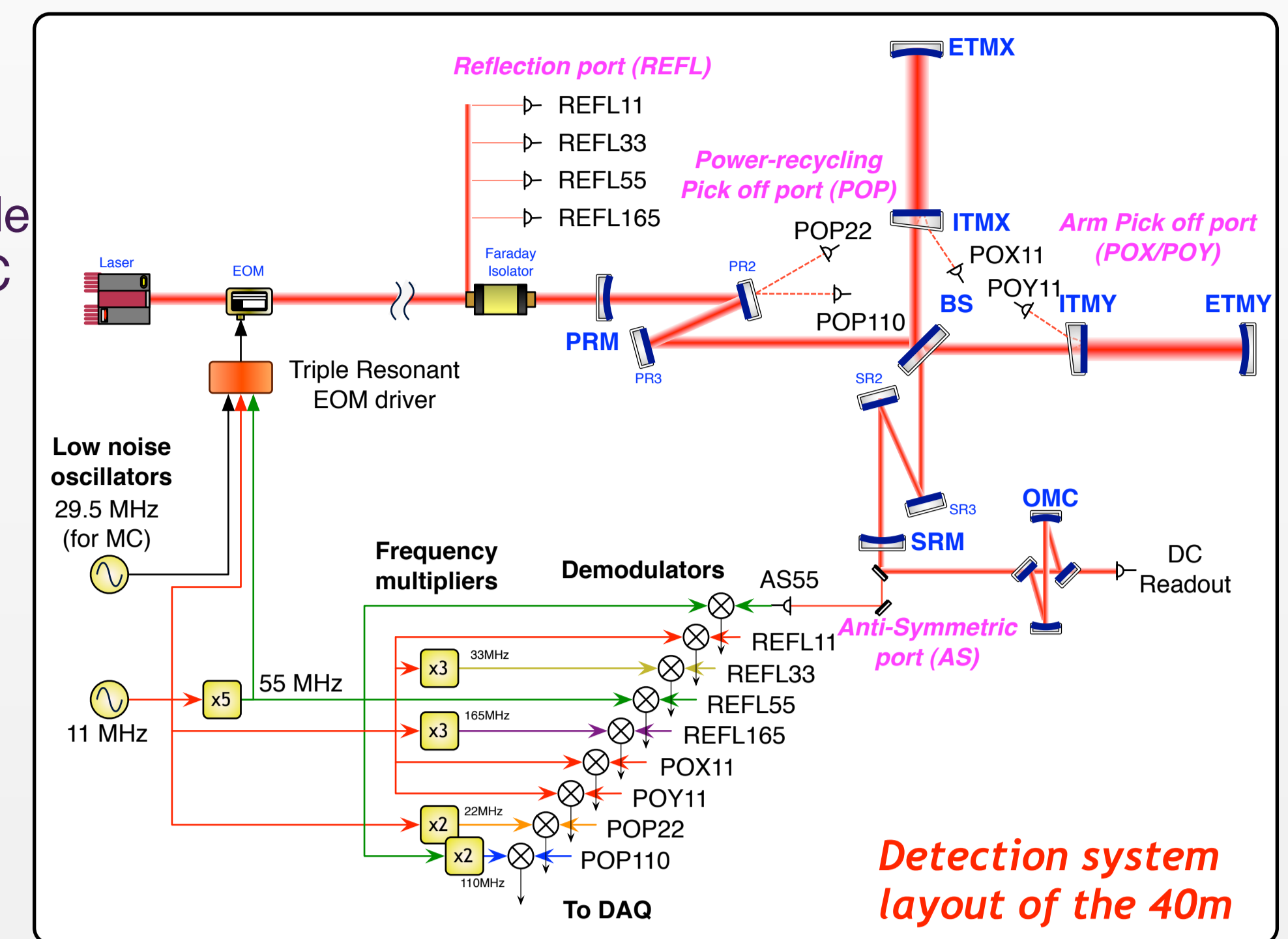

Arm length stabilization with auxiliary beam injection [1]

- 532nm beams are generated and injected into the arm cavities

The beat note between the 532nm beams from the aux lasers and the PSL contain information about the arm cavity length fluctuations. Using this information the arm cavity lengths can be stabilized with respect to the PSL frequency even before they are actually brought into resonance with it.

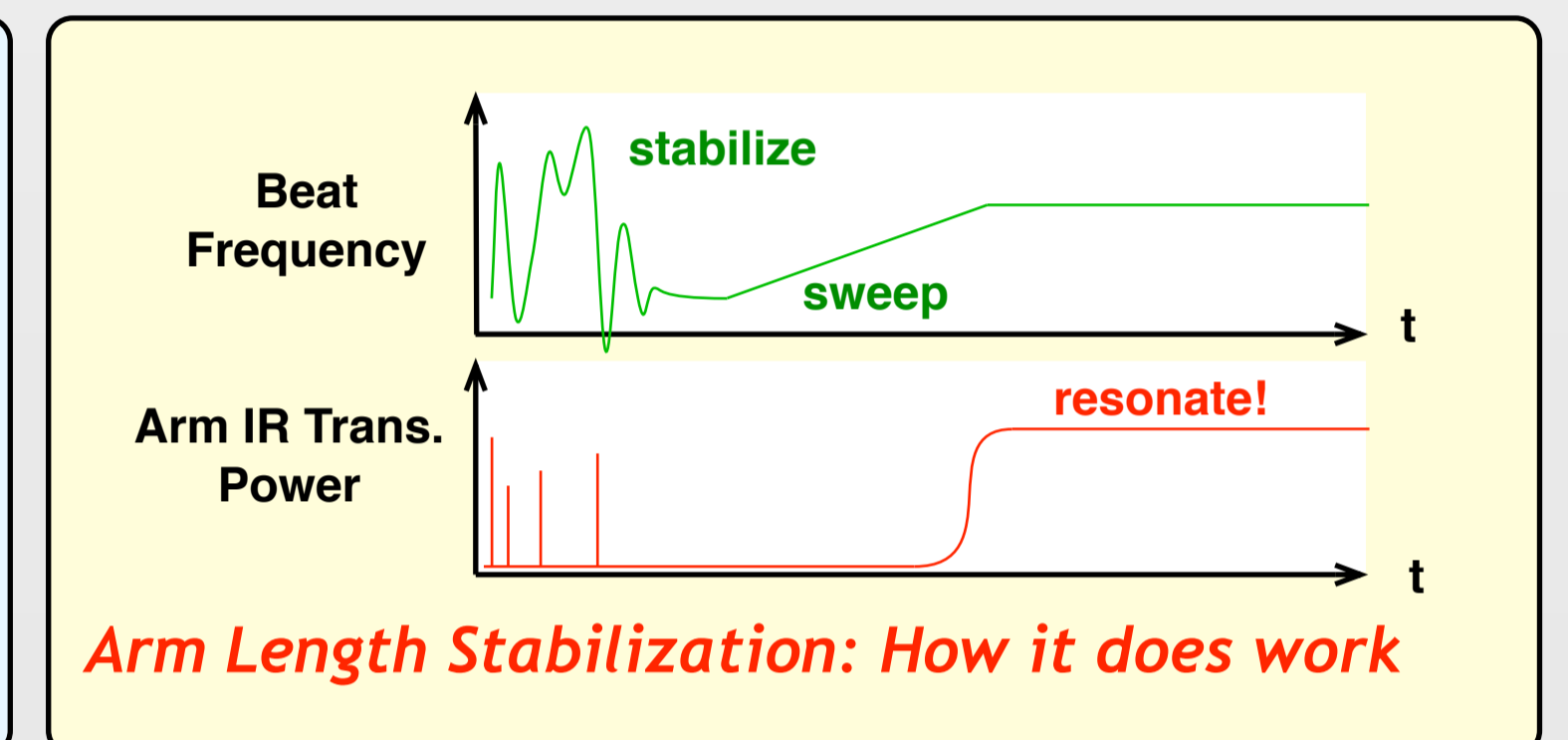
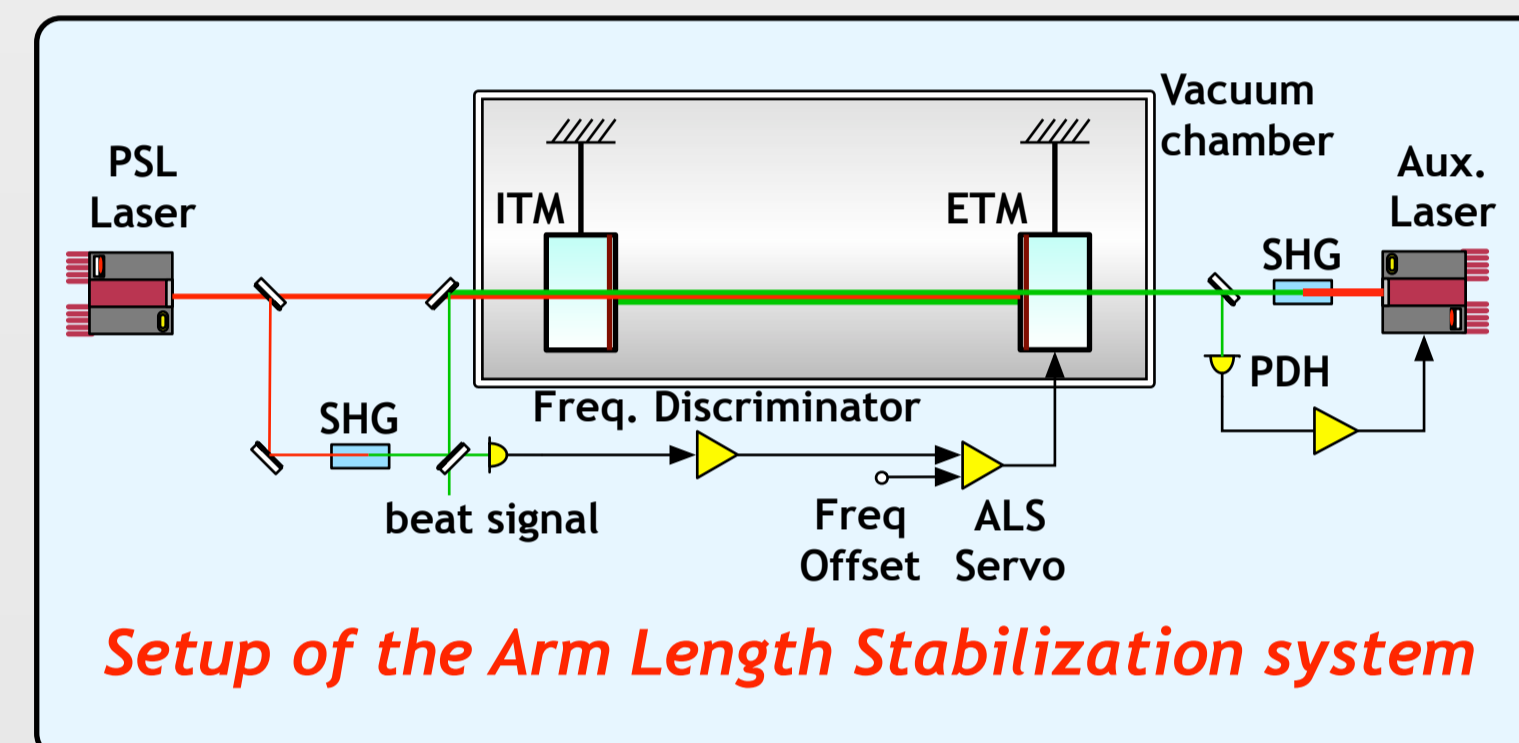

Digital control system

New aLIGO-style digital control system

- Distributed real-time control

Real-time control processes on the CPUs of a single host share the signals acquired by I/O Process via shared memory.

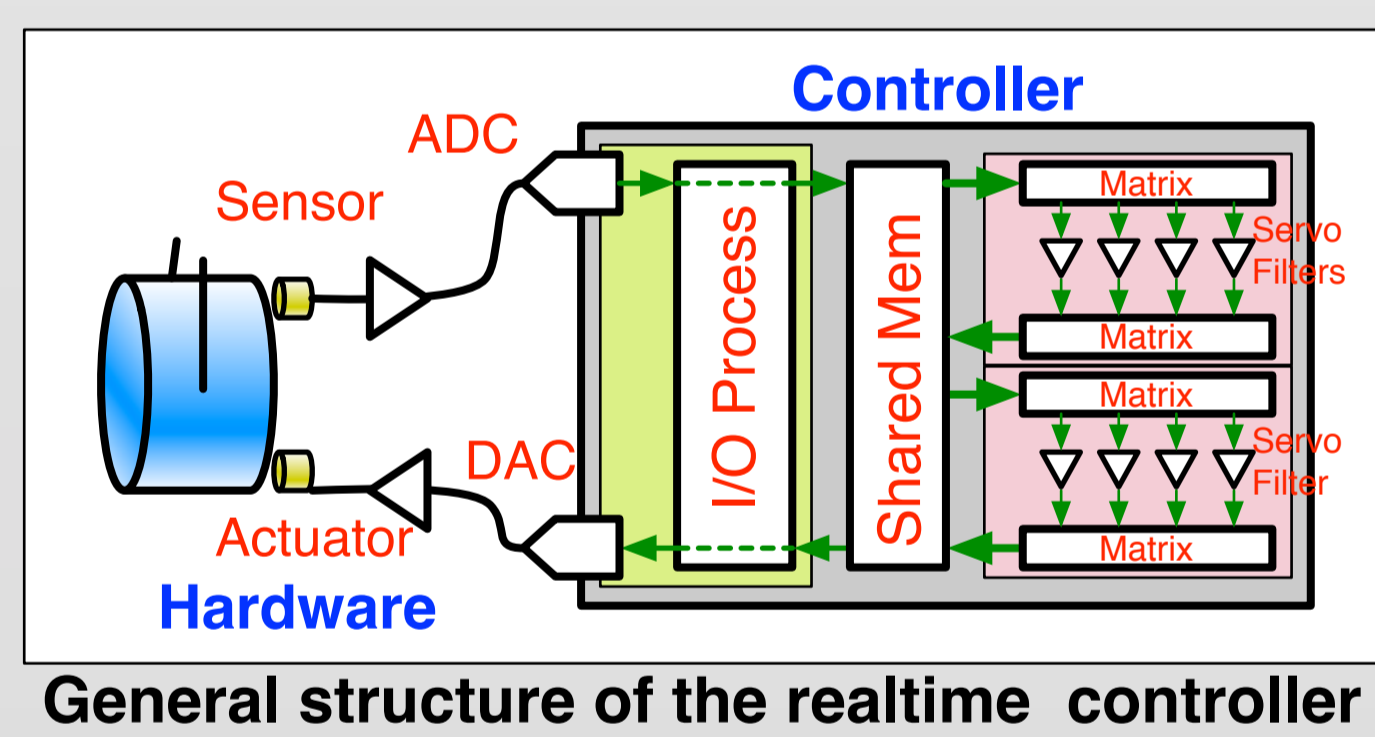
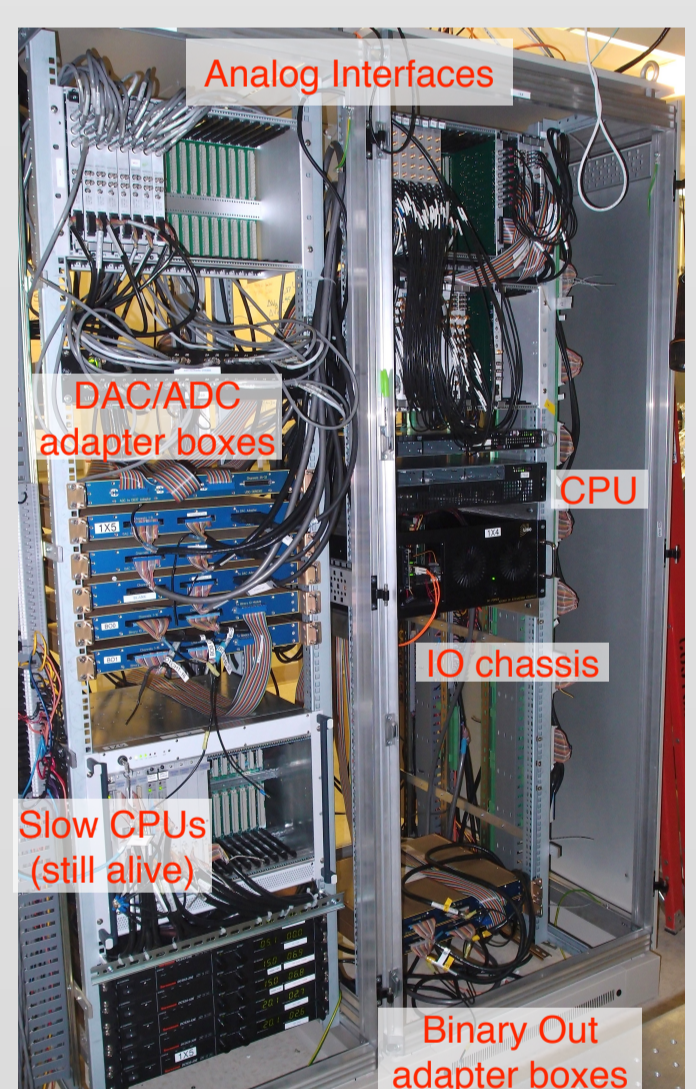

5 multiple-core controller hosts are connected with reflective memory networks.

Data stream is acquired through a dedicated high-speed network.

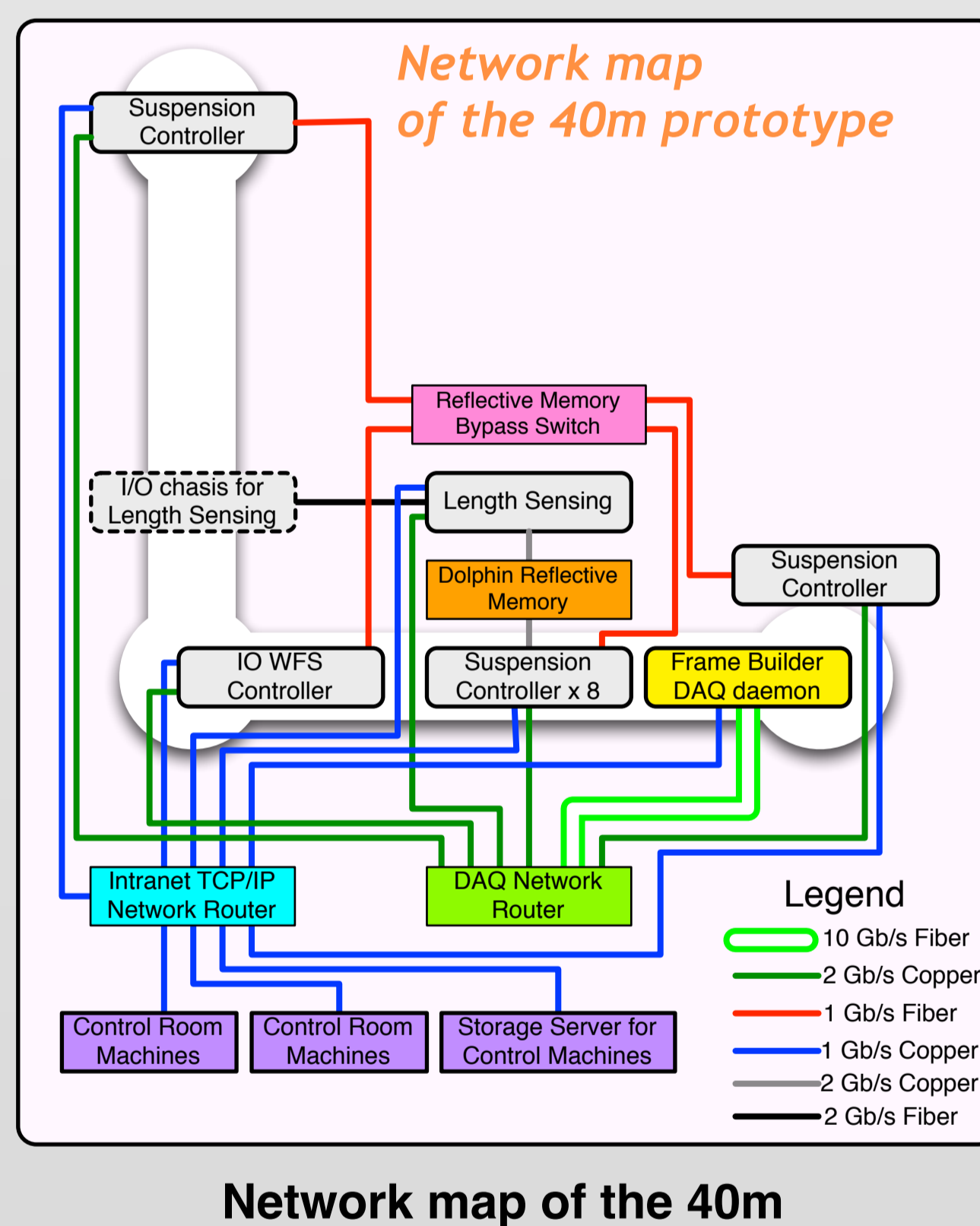

Simulated plant on the digital control

Interferometer emulator as a commissioning tool [2, 3]

Replace hardwares by digital filters with equivalent responses

The controller model can run without real hardwares. The models could then be tested on the Simulated Plant even if the real IFO is off-line. Conversely, the response of the real hardware can be compared with the predicted behaviour of the simulated plants. This would help us in the debugging of the interferometer control.

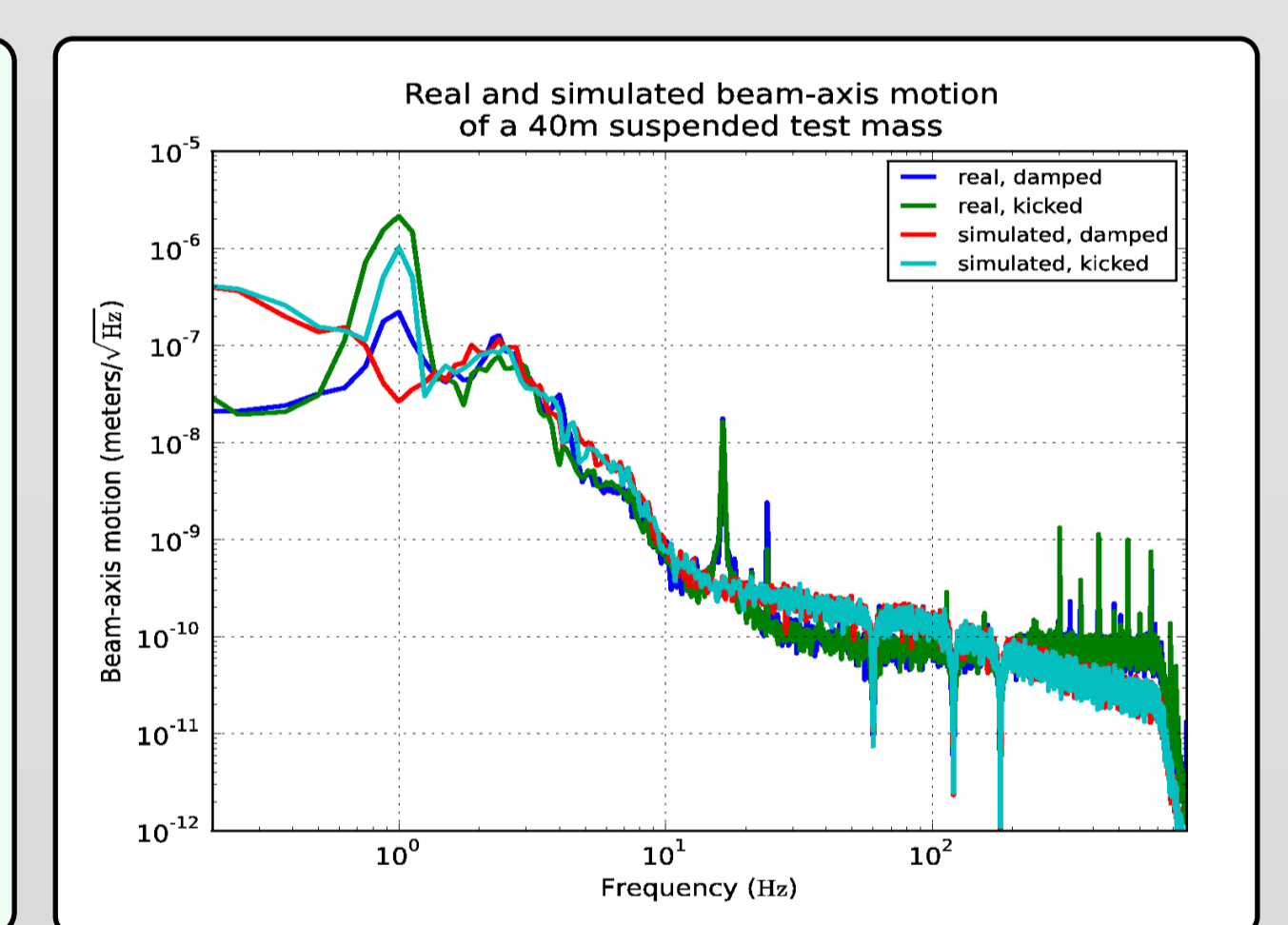
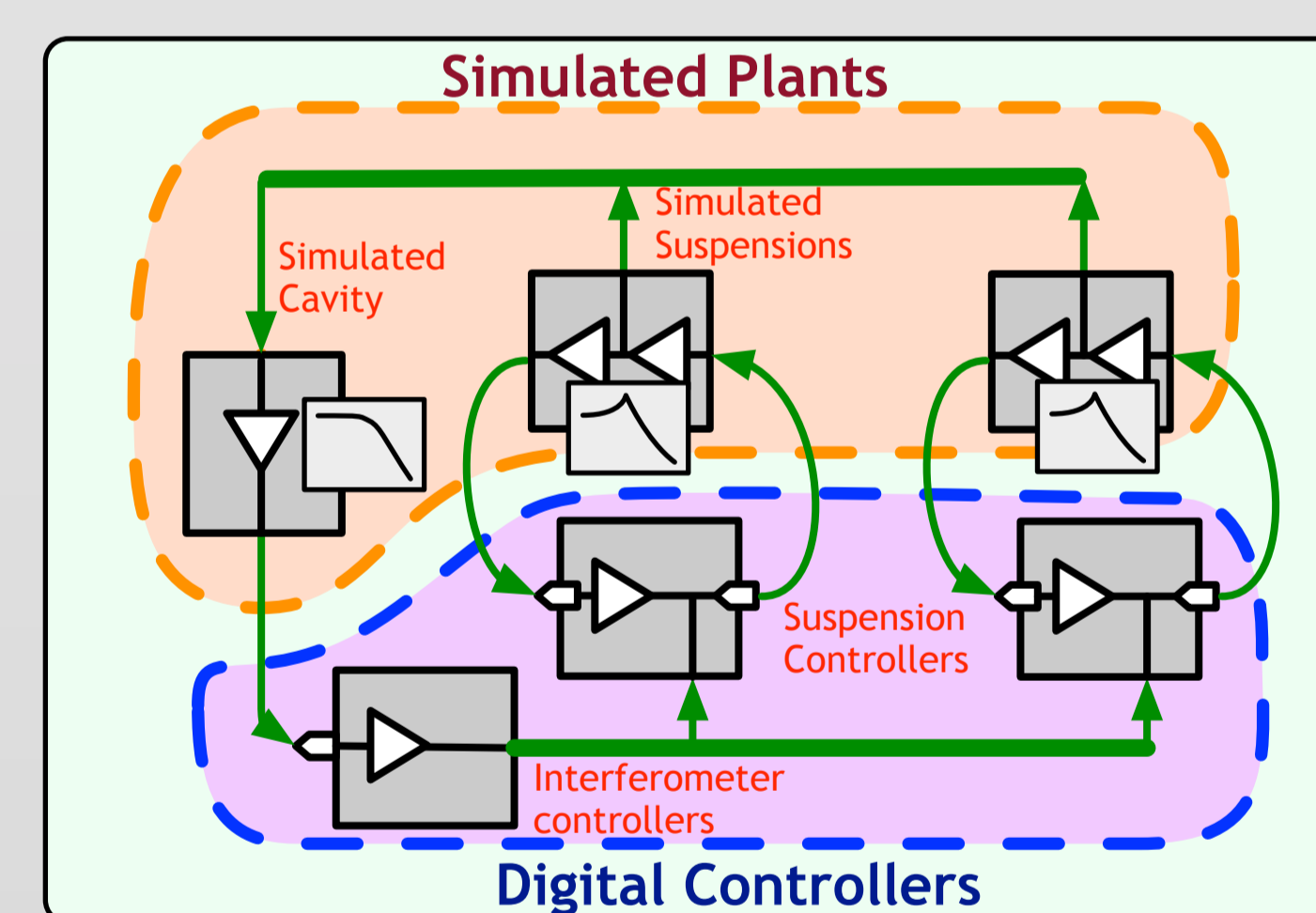

Adaptive seismic noise cancellation

Utilizing seismic feedforward to cancel the motion of the test masses [4]

- The seismic feedforward works as an active vibration isolation

even in the low freq band where the passive isolation is not effective

- Also applicable to Newtonian gravity noise subtraction

Experimental Setup

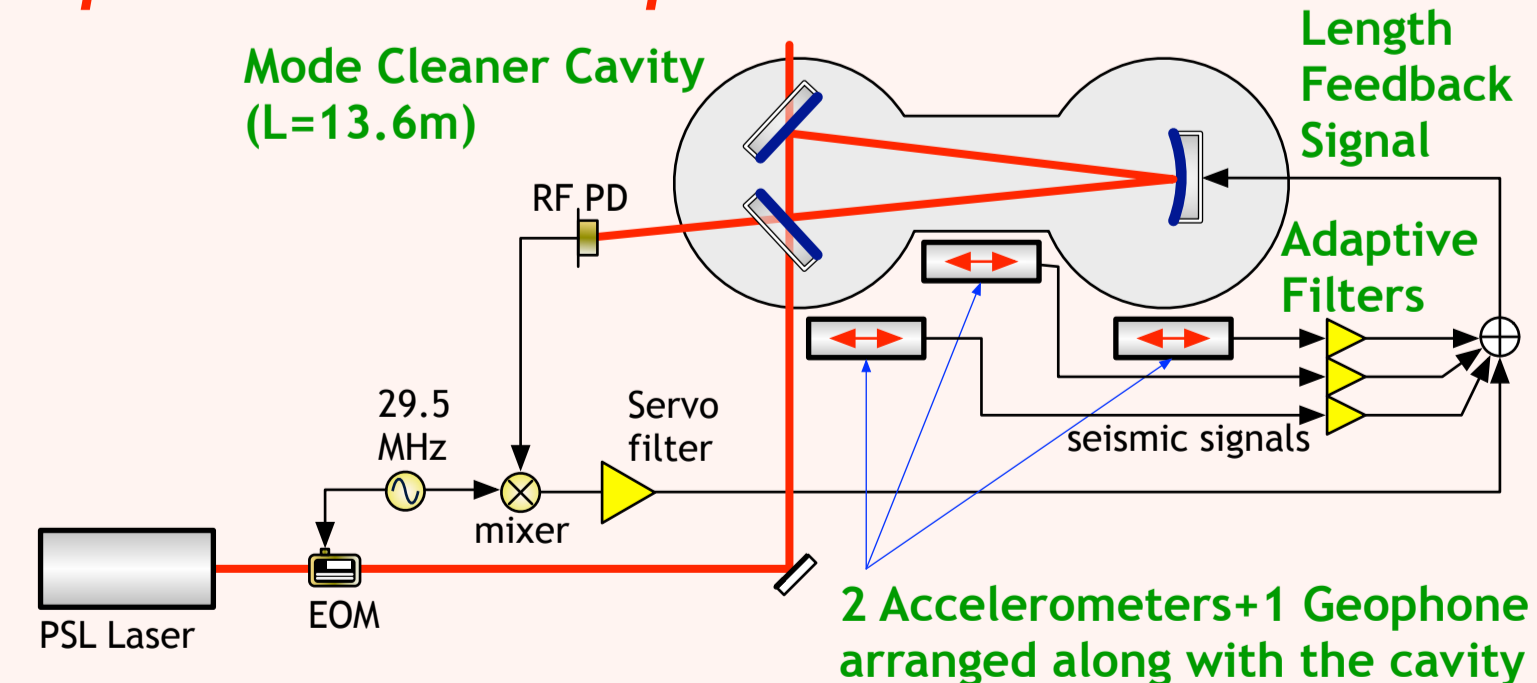

Adaptive filtering algorithm (LMS or FxLMS)

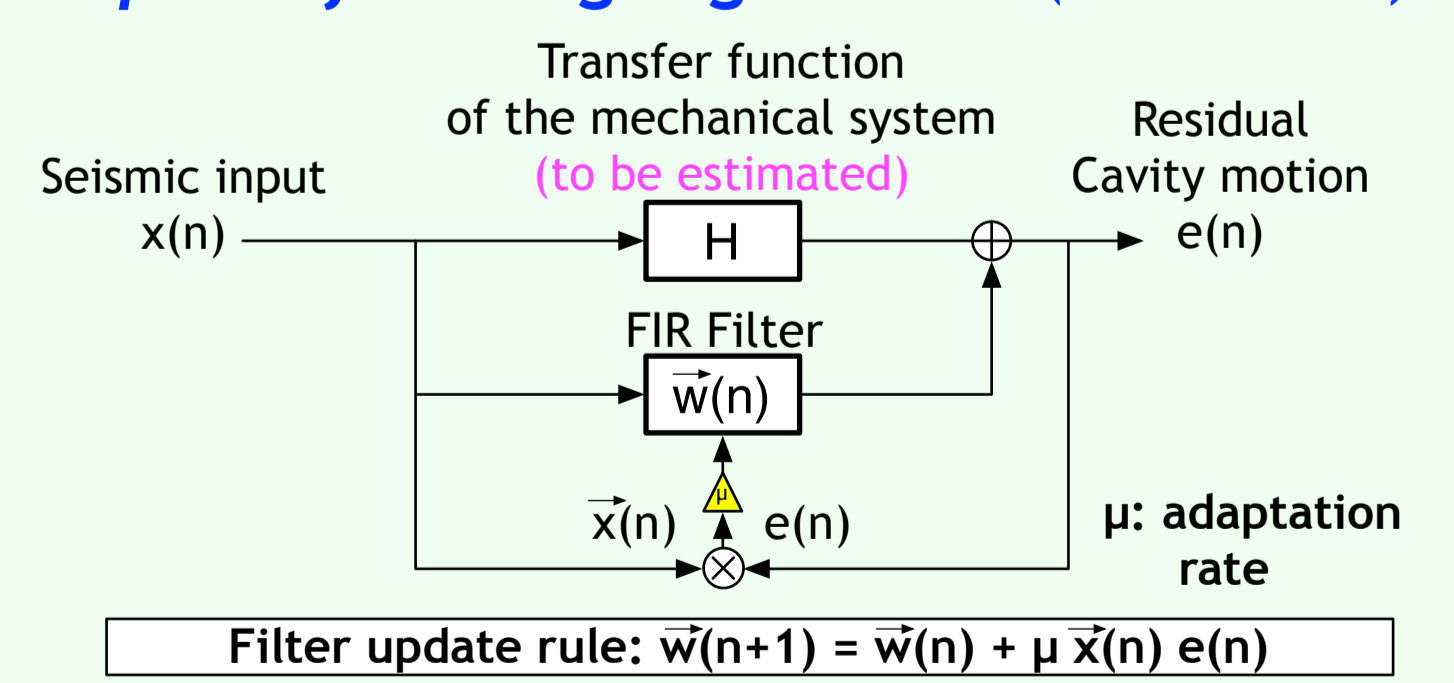

- Demonstrated reduction of the MC motion with adaptive filtering

three sensor signals are used for the adaptive feedforward
the cavity motion was **reduced by a factor of 17 at 3Hz**

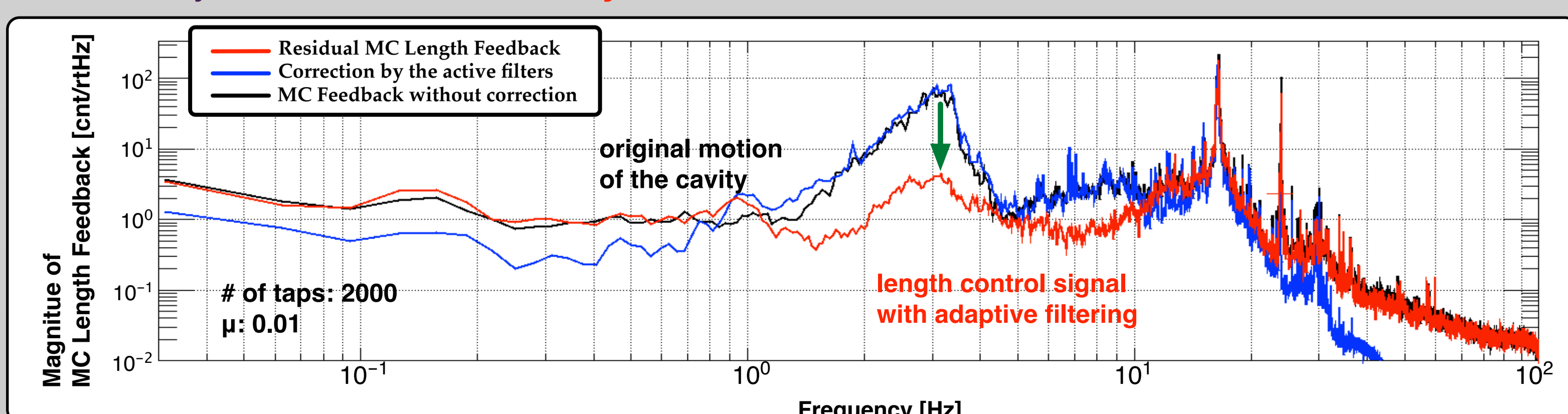

Status & Plans

• Interferometer sensing and control:

- Two arms are locked with 532nm and 1064nm beams

- Arm length stabilization of 200pm_{RMS} has been realized

with auxiliary 532nm laser injection from one of the arm end

- Dual-recycled Michelson is regularly locked and is operating

=> Plan: Characterization of DRM1

Demonstration of full lock with Arm Length Stabilization

• Digital control system

- Controllers for the suspensions and length control were implemented

- Simulated plant: suspensions and a simple cavity have been modeled

=> Plan: Expansion of the simulated models for full IFO

• Adaptive seismic noise cancellation

- Achieved reduction of the MC length change

=> Plan: Implementation of the technique to the main arm cavities

References:
[1] K. Izumi, et al. "The 40m interferometer : prototyping aLIGO locking scheme", LIGO Document G1100820
[2] K. Arai, et al. "Simulated Plant Approach", LIGO Document G1000546
[3] J. Betzwieser, et al. "Real Controls with a Simulated Plant at the 40m", LIGO Document G1100524
[4] J. Driggers, et al. "Feed Forward Seismic Isolation", LIGO Document G1000234

