

NOTES CONTINUED:

5. SCRIBE, ENGRAVE, LASER MARK OR MECHANICALLY STAMP (NO DYES OR INKS) A UNIQUE THREE DIGIT SERIAL NUMBER & REVISION NUMBER ON EACH PART. SERIAL NUMBERS START AT 001 FOR THE FIRST ARTICLE AND PROCEED CONSECUTIVELY. BAG AND TAG PARTS WITH THEIR DRAWING PART NUMBER, REVISION, VARIANT OR "TYPE" (IF APPLICABLE), AND QUANTITY, IF PARTS ARE TOO SMALL TO SCRIBE, BAGGING AND TAGGING ALONE IS SUFFICIENT.
 EXAMPLE (PART): 001-v1
 EXAMPLE (TAG): DXXXXXX-VY, TYPE-XX, QTY: TBD

- 6. APPROXIMATE WEIGHT = X.XXX LB.
- 7. MACHINE ALL SURFACES TO REMOVE OXIDES AND MILL FINISH. USE OF ABRASIVE REMOVAL TECHNIQUES IS NOT ALLOWED. REFER TO LIGO-E0900364
- 8. ALL PARTS SHALL BE MANUFACTURED IN ACCORDANCE WITH LIGO SPECIFICATION E0900364.
- 11. ALL MATERIAL IS TO BE VIRGIN MATERIAL (i.e. NO WELD REPAIRS, PLUGS OR RECYCLED MATERIAL). NO REPAIRS SHALL BE MADE UNLESS APPROVED IN ADVANCE, AND IN WRITING, BY LIGO LABORATORY. REFER TO LIGO-E0900364.
- 12. SURFACE FINISH TO BE AS-PROCESSED FROM MILL/SUPPLIER, FREE FROM SCRATCHES OR GOUGES.

| REV. | DATE | DCN # | DRAWING TREE # |
|------|------|-------|----------------|
| - | - | - | - |
| - | - | - | - |
| - | - | - | - |

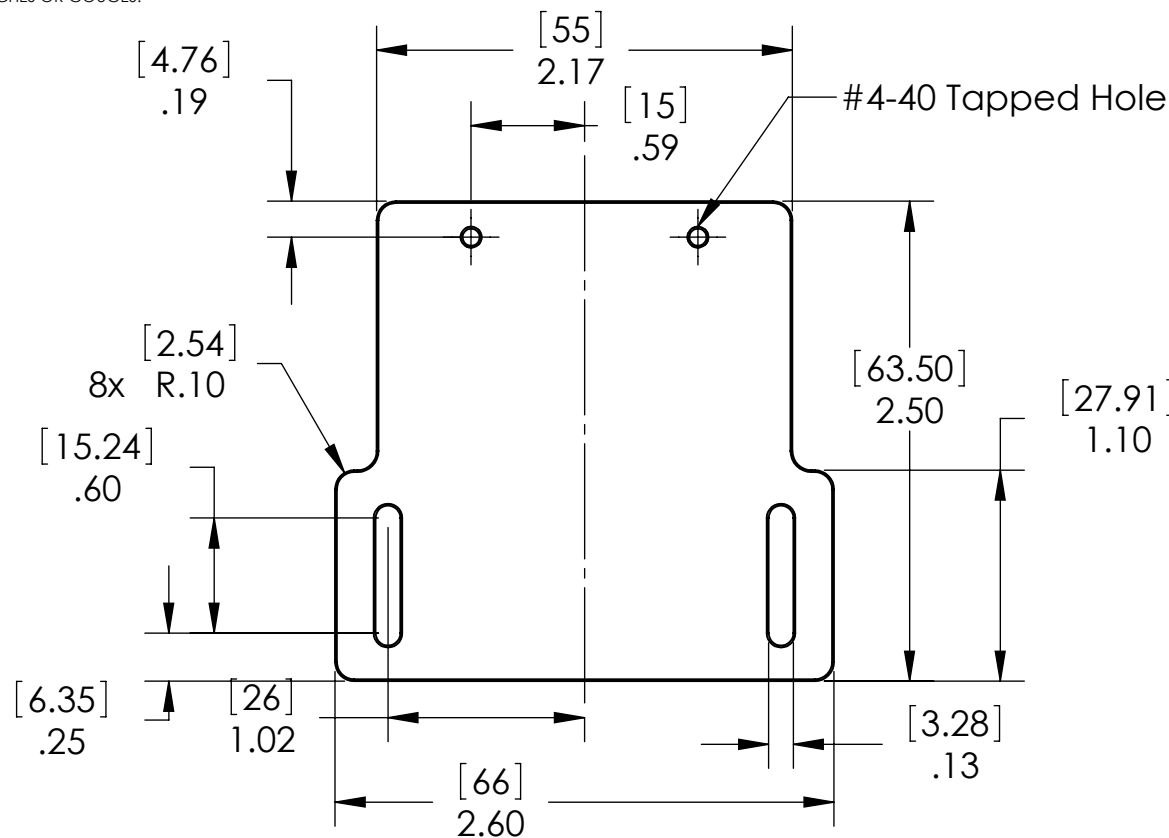
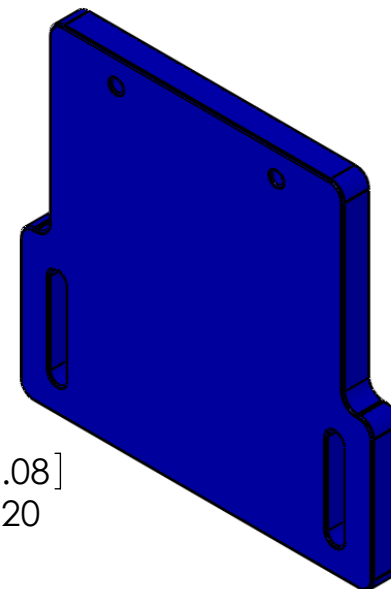

NOTES AND TOLERANCES: (UNLESS OTHERWISE SPECIFIED)

DIMENSIONS ARE IN INCHES [MM]
 TOLERANCES:
 .XX ± .05
 .XXX ± .005
 ANGULAR ± 0.4°

1. INTERPRET DRAWING PER ASME Y14.5-1994.
 2. REMOVE ALL SHARP EDGES, .005-.015, FOR MACHINED PARTS. ROUND ALL EDGES APPROXIMATELY R.02 FOR SHEET METAL PARTS.
 3. DO NOT SCALE FROM DRAWING.
 4. ALL MACHINING FLUIDS MUST BE FULLY SYNTHETIC, FULLY WATER SOLUBLE AND FREE OF SULFUR, SILICONE, AND CHLORINE.
 MATERIAL 6061-T6 Al
 FINISH 63 μinch

LIGO CALIFORNIA INSTITUTE OF TECHNOLOGY
 MASSACHUSETTS INSTITUTE OF TECHNOLOGY

SYSTEM **ADVANCED LIGO** SUB-SYSTEM **ISC**

NEXT ASSY **Tip-Tilt Structure**

| | | | |
|-----------|---------------|------------------------------|--------------------------------------|
| PART NAME | | Tip-Tilt DSUB Bracket Holder | |
| DESIGNER | BJJ Slagmolen | 17 July 11 | SIZE DWG. NO. |
| DRAFTER | BJJ Slagmolen | 17 Jul 11 | A D1101430 |
| CHECKER | | | REV. v1 |
| APPROVAL | | | SCALE: 1:1 PROJECTION: SHEET 1 OF 1 |