

NOTES CONTINUED:

- 5. SCRIBE, ENGRAVE (A VIBRATORY TOOL MAY BE USED), LASER MARK OR MECHANICALLY STAMP (NO INKS OR DYES) DRAWING PART NUMBER, REVISION (AND VARIANT OR "TYPE" IF APPLICABLE) ON NOTED SURFACE OF PART FOLLOWED ON THE NEXT LINE WITH A THREE DIGIT SERIAL NUMBER. SERIAL NUMBERS START AT 001 FOR THE FIRST ARTICLE AND PROCEED CONSECUTIVELY. USE MINIMUM 0.12" HIGH CHARACTERS, UNLESS THE SIZE OF THE PART DICTATES SMALLER CHARACTERS. EXAMPLE: DXXXXXX-VY, TYPE-XX, S/N XXX
- 6. APPROXIMATE WEIGHT = .612 LB.
- 7. ALL MATERIAL IS TO BE VIRGIN MATERIAL (i.e. NO WELD REPAIRS, PLUGS OR RECYCLED MATERIAL), NO REPAIRS SHALL BE MADE UNLESS APPROVED IN ADVANCE, AND IN WRITING, BY LIGO LABORATORY. REFER TO LIGO-E0900364.
- 8. MACHINE ALL SURFACES TO REMOVE OXIDES AND MILL FINISH, USE OF ABRASIVE REMOVAL TECHNIQUES IS NOT ALLOWED. REFER TO LIGO-E0900364
- 9. ALL PARTS SHALL BE MANUFACTURED IN ACCORDANCE WITH LIGO SPECIFICATION E0900364.
- 10. ALL HELI-COIL HOLES TO BE PREPARED ACCORDING TO EMHART HELI-COIL PRODUCT CATALOG, HC2000, REV 4
- 11. ALL HELI-COIL INSERTS TO BE INSTALLED BY LIGO PERSONNEL, AFTER DELIVERY OF FINISHED PARTS, USE NITRONIC 60 THREADED INSERTS.

REV.	DATE	DCN #	DRAWING TREE #
v1	11 JUL 2011	E1100335	-
v2	25 JUL 2011	E1100335	-
v3	6 SEP 2012	E1100335-v5	-

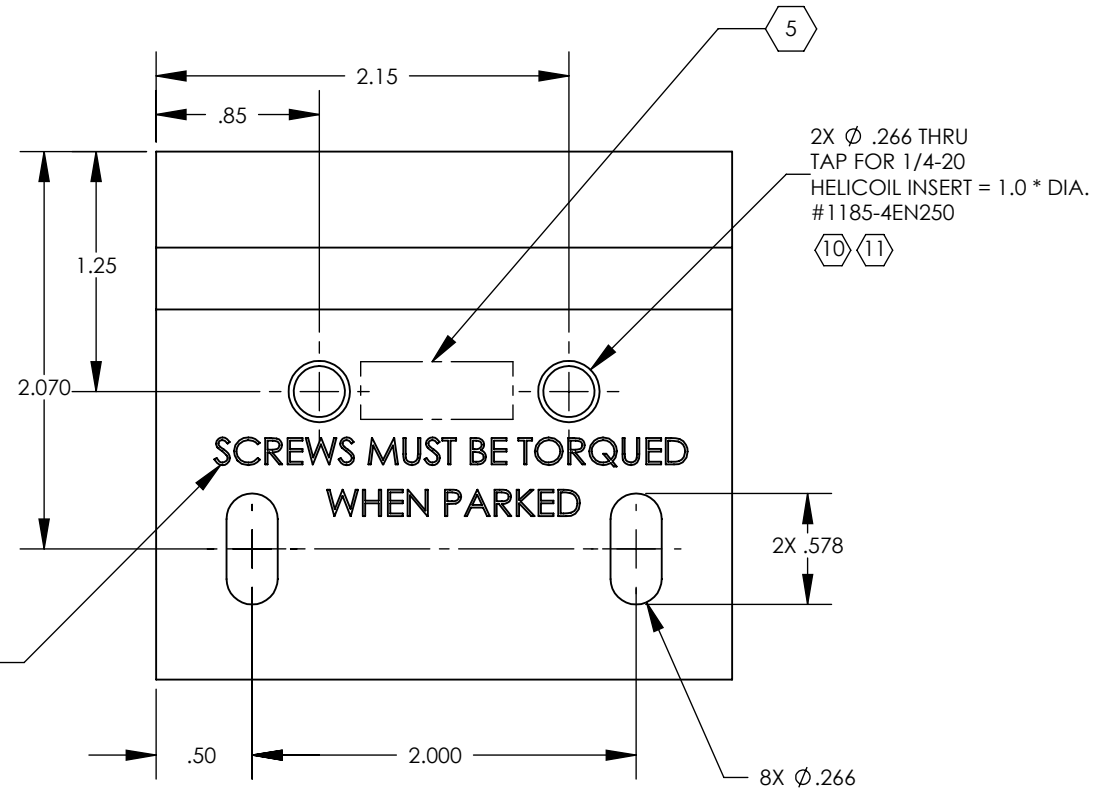
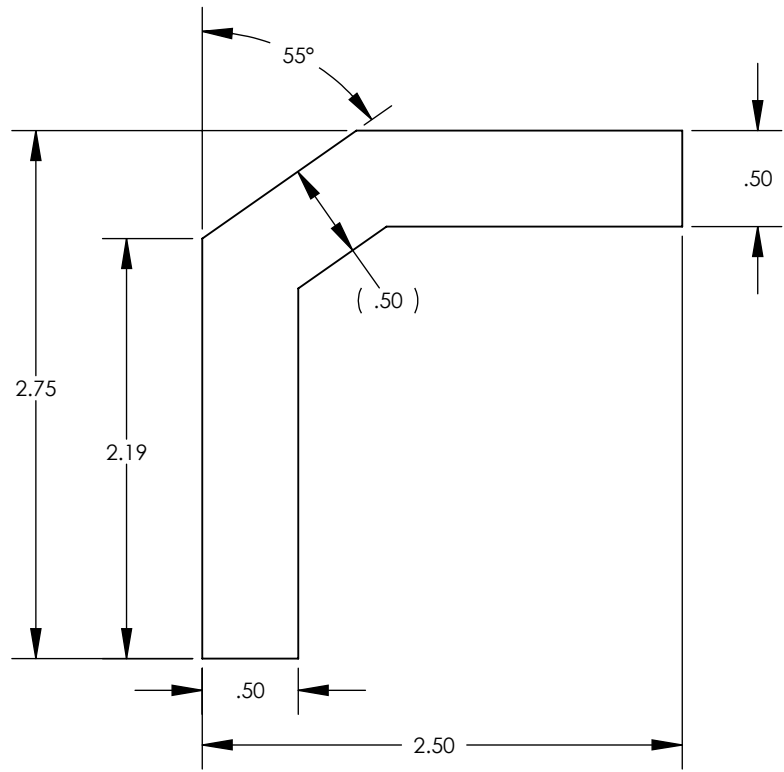
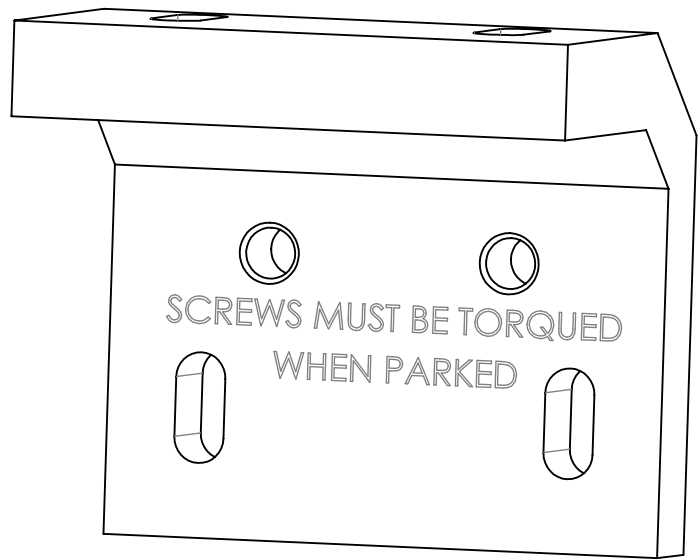
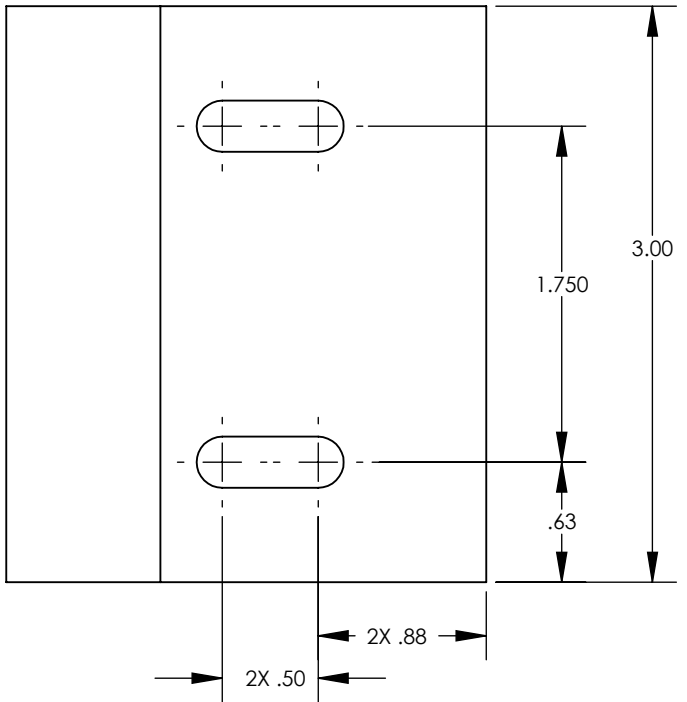

D1101285 Transport, Locking, ACB, PART PDM REV: X-013, DRAWING PDM REV: X-020

NOTES AND TOLERANCES: (UNLESS OTHERWISE SPECIFIED)	
DIMENSIONS ARE IN	1. INTERPRET DRAWING PER ASME Y14.5-1994.
TOLERANCES:	2. REMOVE ALL SHARP EDGES, .005-.015, FOR MACHINED PARTS. ROUND ALL EDGES APPROXIMATELY R.02 FOR SHEET METAL PARTS.
.XX ± .03	3. DO NOT SCALE FROM DRAWING.
.XXX ± .010	4. ALL MACHINING FLUIDS MUST BE FULLY SYNTHETIC, FULLY WATER SOLUBLE AND FREE OF SULFUR, SILICONE, AND CHLORINE.
ANGULAR ± .5°	
MATERIAL	6061-T6 Al
FINISH	63 μinch

CALIFORNIA INSTITUTE OF TECHNOLOGY MASSACHUSETTS INSTITUTE OF TECHNOLOGY		PART NAME		TRANSPORT, LOCKING, ACB	
SYSTEM	ADVANCED LIGO	SUB-SYSTEM	AOS	DESIGNER	
DRAFTER		CHECKER	MRUIZ	DATE	08 JUL 2011
CHECKER		APPROVAL		SIZE	DWG. NO.
				B	D1101285
				REV.	v3
				SCALE:	1:1
				PROJECTION:	
					SHEET 1 OF 1