

LASER INTERFEROMETER GRAVITATIONAL WAVE OBSERVATORY
-LIGO-
CALIFORNIA INSTITUTE OF TECHNOLOGY
MASACHUSETTS INSTITUTE OF TECHNOLOGY

LIGO- E1100607-v1	6/22/11
SLC Manifold/Cryopump Baffle Installation Document	
Michael Smith	

LIGO Hanford Observatory
P.O. Box 1970; Mail Stop S9-02
Richland, WA 99352
Phone (509) 37208106
Fax (509) 372-8137
E-mail: info@ligo.caltech.edu

LIGO Livingston Observatory
19100 LIGO Lane
Livingston, LA 70754
Phone (225) 686-3100
Fax (225) 686-7189
E-mail: info@ligo.caltech.edu

California Institute of Technology
LIGO – MS 18-34
Pasadena, CA 91125
Phone (626) 395-2129
Fax (626) 304-9834
E-mail: info@ligo.caltech.edu

Massachusetts Institute of Technology
LIGO – MS NW22-295
Cambridge, MA 01239
Phone (617) 253-4824
Fax (617) 253-7014
E-mail: info@ligo.mit.edu

Table of Contents

1	SCOPE	3
2	MANIFOLD/CRYOPUMP BAFFLE	4
2.1	Assembly	4
3	MODE CLEANER TUBE BAFFLE	10
3.1	Assembly and Installation	10

Table of Tables

No table of figures entries found.

Table of Figures

<i>Figure 1: Manifold/cryopump Baffle Assembly and Transport Apparatus</i>	<i>4</i>
<i>Figure 2: Baffle in Horizontal Orientation during Assembly.....</i>	<i>5</i>
<i>Figure 3: Baffle being Transported to Opening of Manifold spool.....</i>	<i>7</i>
<i>Figure 4: Baffle Inserted inside Manifold Spool and Suspended from Blade Springs</i>	<i>8</i>
<i>Figure 5: ITMX H1-L1 Manifold/Cryopump Baffle Positioned in the B-9 Spool next to A-1 Viewport Adapter.....</i>	<i>9</i>
<i>Figure 6: MCA1, H1-L1, HAM2.....</i>	<i>10</i>
<i>Figure 7: Bottom Central Portion of Baffle Sitting inside Mode Cleaner Tube.....</i>	<i>11</i>

1 Scope

This document describes the assembly and installation procedures for the Manifold/Cryopump Baffle and the Mode Cleaner Tube Baffles.

2 MANIFOLD/CRYOPUMP BAFFLE

2.1 Assembly

The baffle is assembled on the assembly/transport apparatus, shown in Figure 1.



Figure 1: Manifold/cryopump Baffle Assembly and Transport Apparatus

The apparatus is pivoted to the horizontal position for the baffle assembly, as shown in Figure 2.

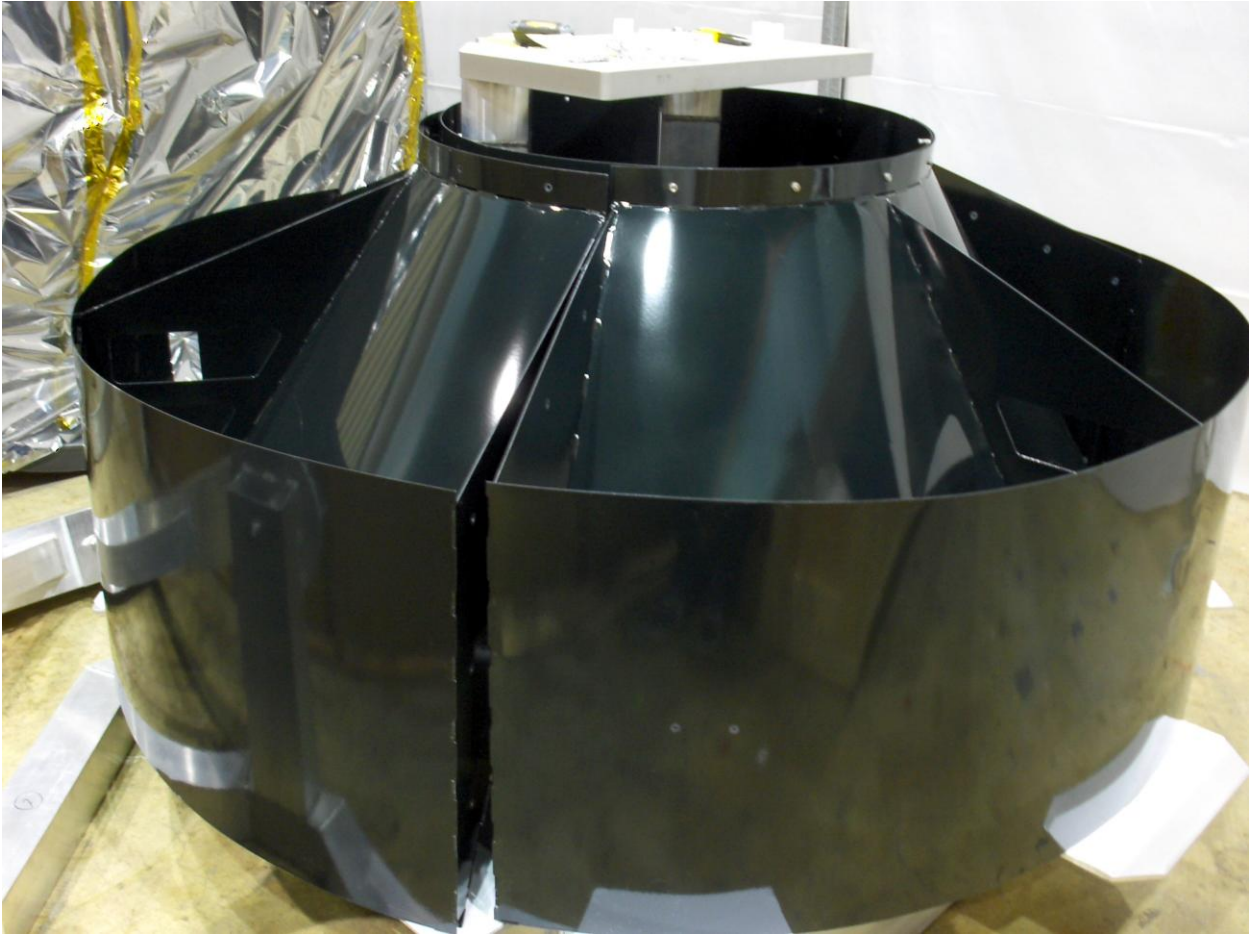
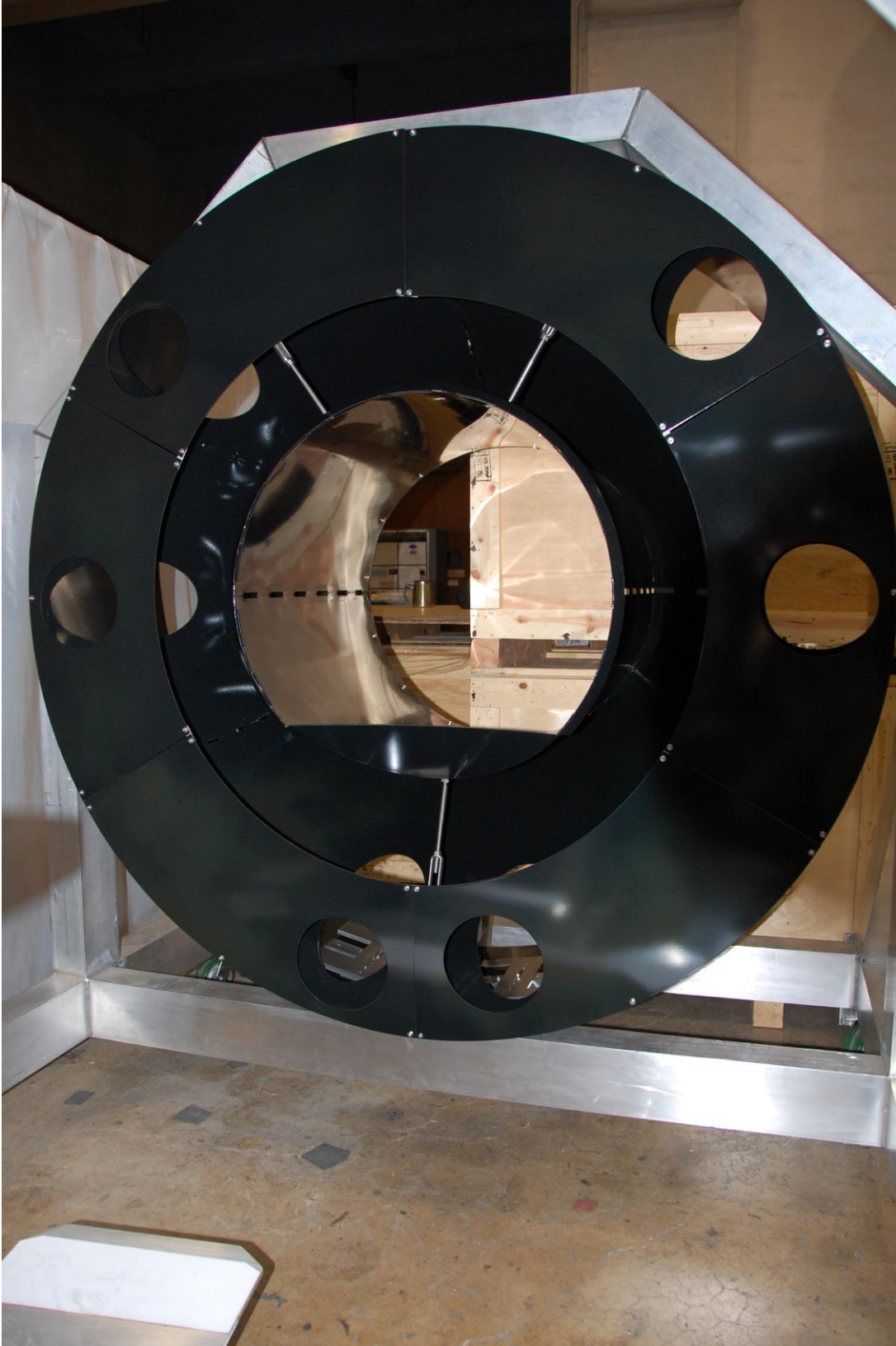

Figure 2: Baffle in Horizontal Orientation during Assembly

The assembly fixture is rotated to orient the baffle in the tube-axis direction, and is transported in the assembly fixture with an overhead crane to the balancing fixture, where the baffle is attached to the blade springs and balanced.



Following the balancing, the baffle is removed from the balancing fixture by means of the transport apparatus. The blade springs are attached to the pre-loading fixture and removed.

The support ring is attached inside the manifold spool; and, the blade springs are reattached.

The baffle is transported into the opening of the manifold spool and inserted into the spool until the attachment points of the baffle suspension align with the suspension rods that are pre-attached to the blade springs.

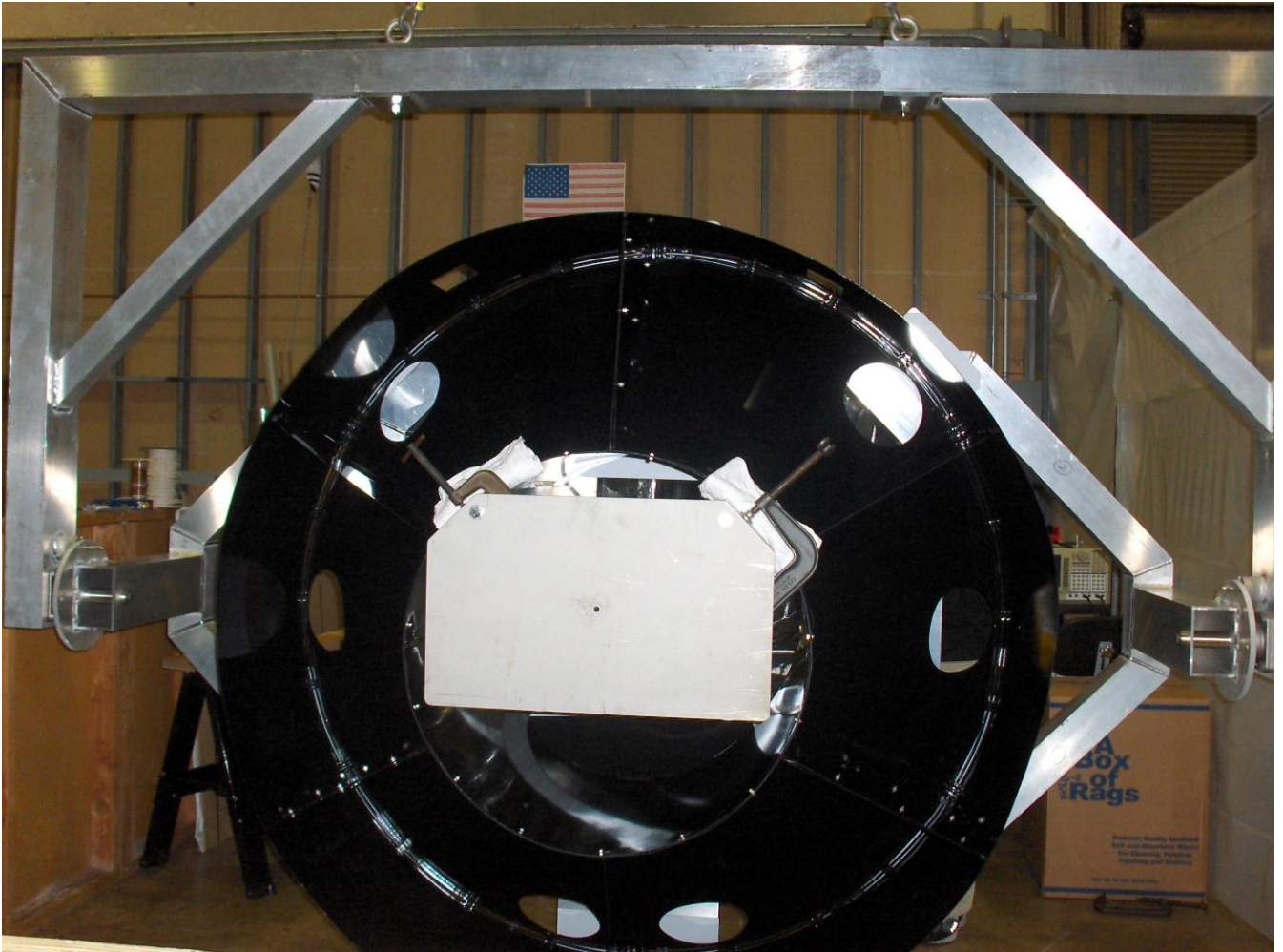

Figure 3: Baffle being Transported to Opening of Manifold spool

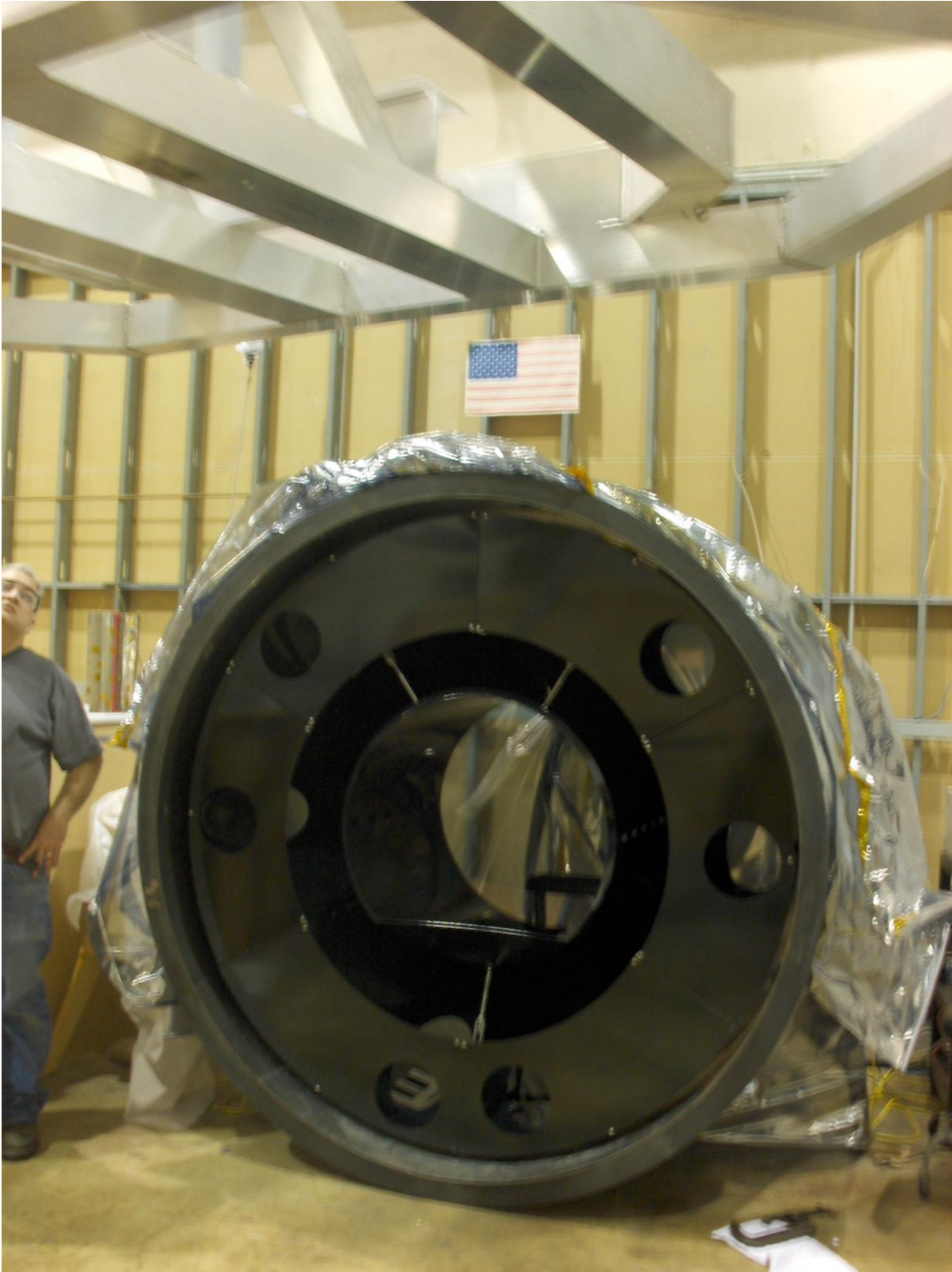

Figure 4: Baffle Inserted inside Manifold Spool and Suspended from Blade Springs

The location of the Manifold/cryopump Baffle inside the B-9 spool is shown in Figure 5.

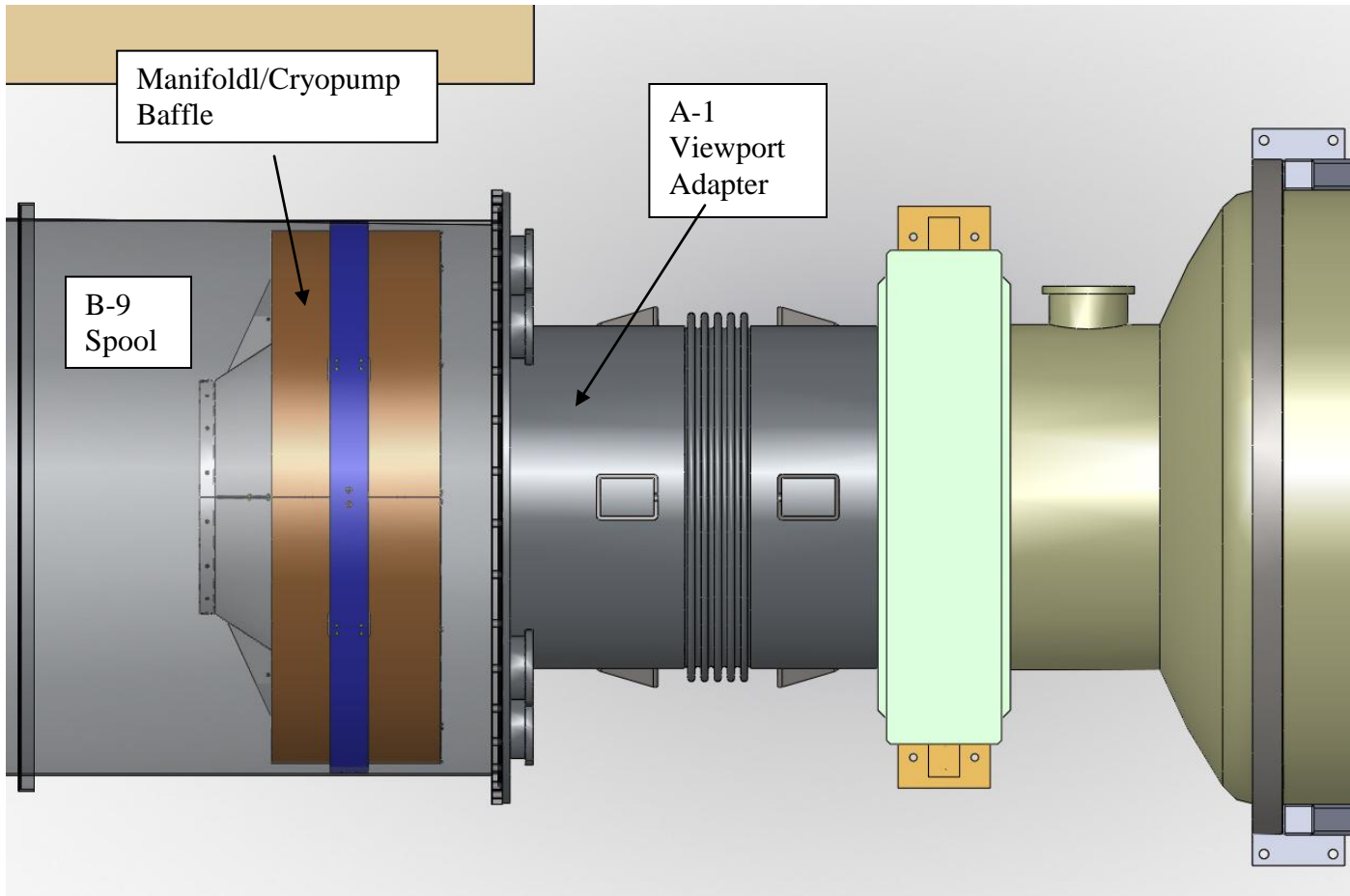

Figure 5: ITMX H1-L1 Manifold/Cryopump Baffle Positioned in the B-9 Spool next to A-1 Viewport Adapter

3 MODE CLEANER TUBE BAFFLE

3.1 Assembly and Installation

The Mode Cleaner Tube Baffles are assembled and installed in the input and output mode cleaner tubes, as shown in Figure 6. One person stands inside the mode cleaner tube; one person stands in the viewport adapter tube; and a third person hands the parts through the door of the HAM chamber. The parts weigh between 20-30 lbs and can be carried by a single person.

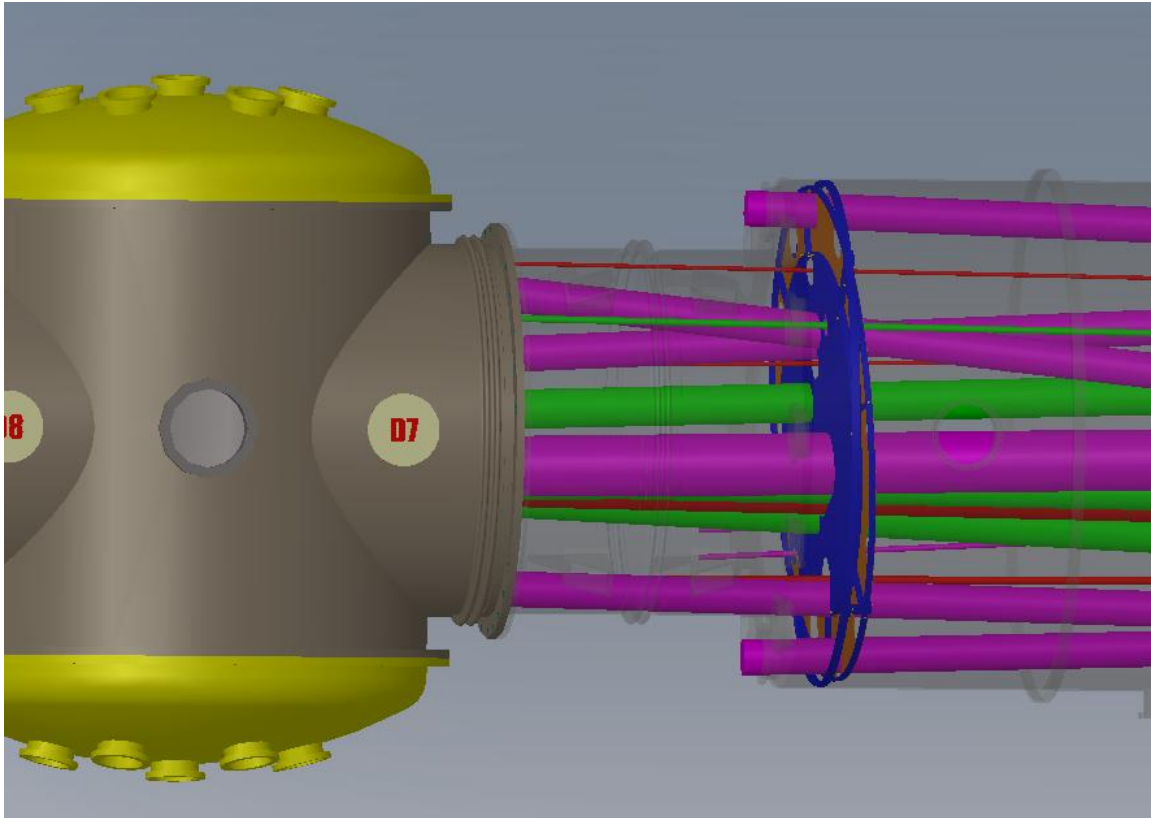

Figure 6: MCA1, H1-L1, HAM2

The support rings are installed by the person standing inside the mode cleaner tube. Next, the outer viewport ring assembly, in two semicircular pieces, are passed through the door of the HAM chamber and handed to another person standing in the viewport adapter just outside the opening to the mode cleaner tube, who hands the parts to the person inside the mode cleaner tube. After the viewport ring assembly is installed, the person inside the mode cleaner tube exits and stands together with the person in the viewport adapter tube.

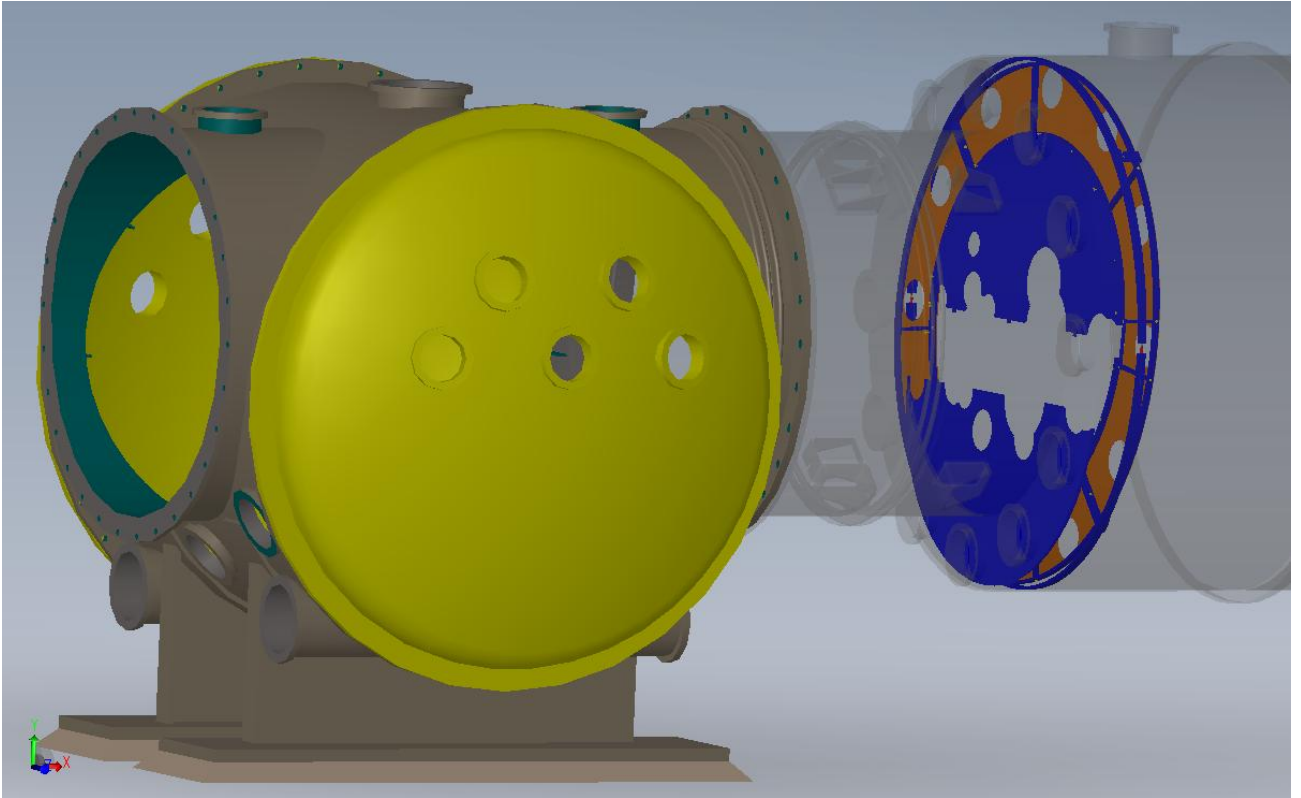

Figure 7: Bottom Central Portion of Baffle Sitting inside Mode Cleaner Tube

The central portion of the baffle is brought inside the viewport adapter tube in two semicircular pieces. The bottom piece is rested on the bottom of the mode cleaner tube between the viewports and the already installed viewport ring assembly of the baffle, as shown in Figure 7.

The top piece is attached to the viewport ring assembly from the outside; and then the bottom piece is attached to the viewport ring assembly.