

NOTES CONTINUED:
 5. MECHANICALLY STAMP (NO INKS OR DYES) PART NUMBER, REVISION AND SERIAL NUMBER .020" DEEP WITH MINIMUM CHARACTER HEIGHT .156" APPROXIMATELY WHERE SHOWN. SERIAL NUMBER WILL START AT 001 AND PROCEED CONSECUTIVELY. EXAMPLE: D100XXX-V1 S/N 001

6. ALL PARTS SHALL BE MANUFACTURED IN ACCORDANCE WITH LIGO SPECIFICATION E0900364.

7. ALL MATERIAL IS TO BE VIRGIN MATERIAL (i.e. NO WELD REPAIRS, PLUGS OR RECYCLED MATERIAL). NO REPAIRS SHALL BE MADE UNLESS APPROVED IN ADVANCE, AND IN WRITING, BY LIGO LABORATORY. REFER TO LIGO-E0900364.

8. SURFACE FINISH TO BE AS-PROCESSED FROM MILL/SUPPLIER, FREE FROM SCRATCHES OR GOUGES.

9. DELETED.

10. DELETED.

11. PART IS NOT TRUE HALF CIRCLE.

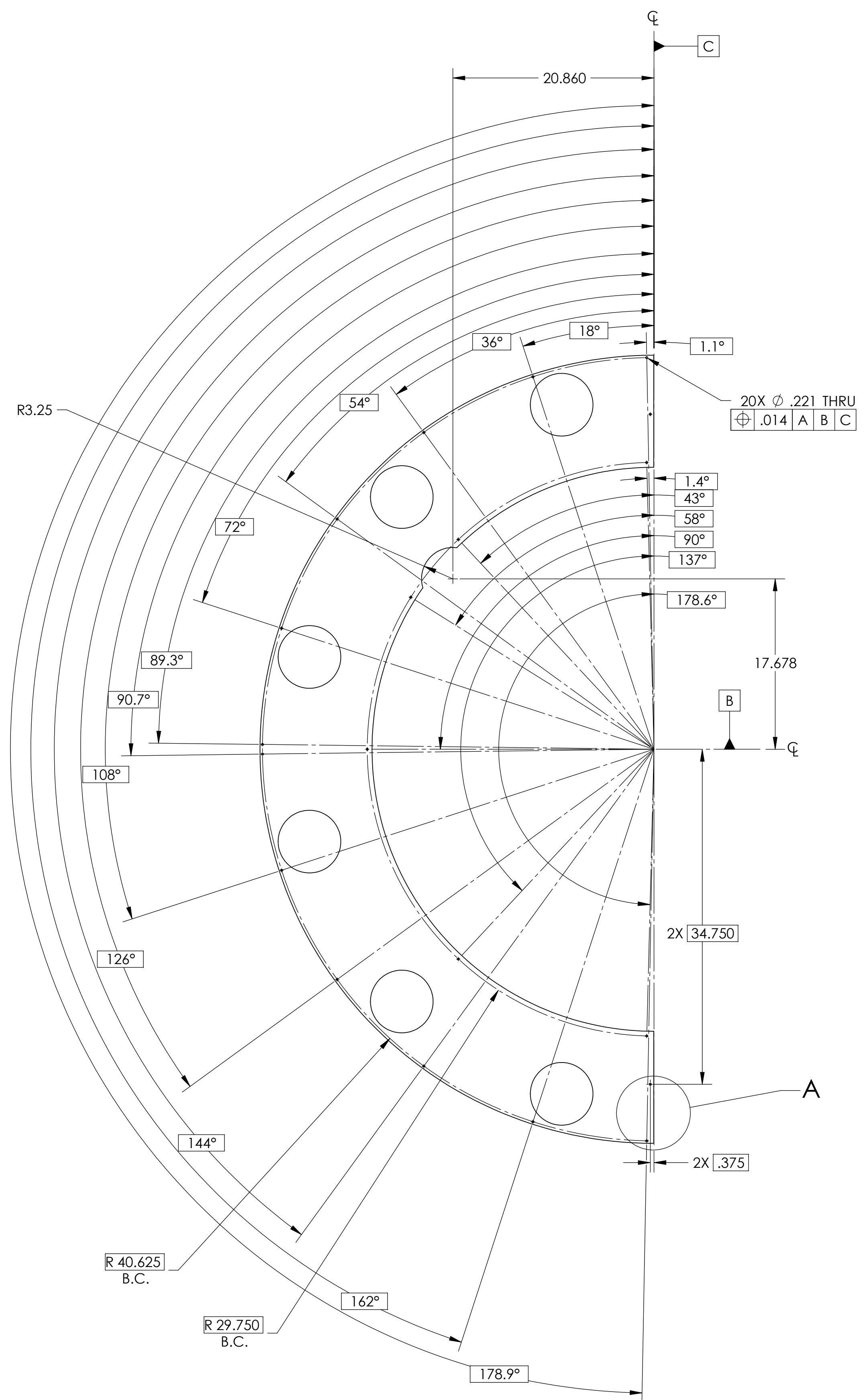
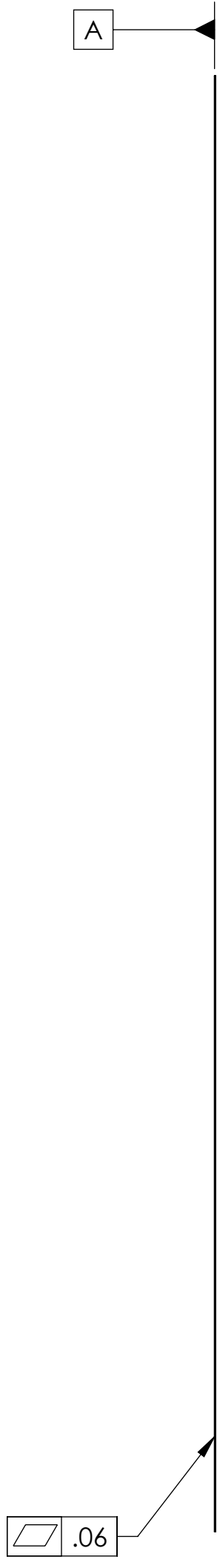
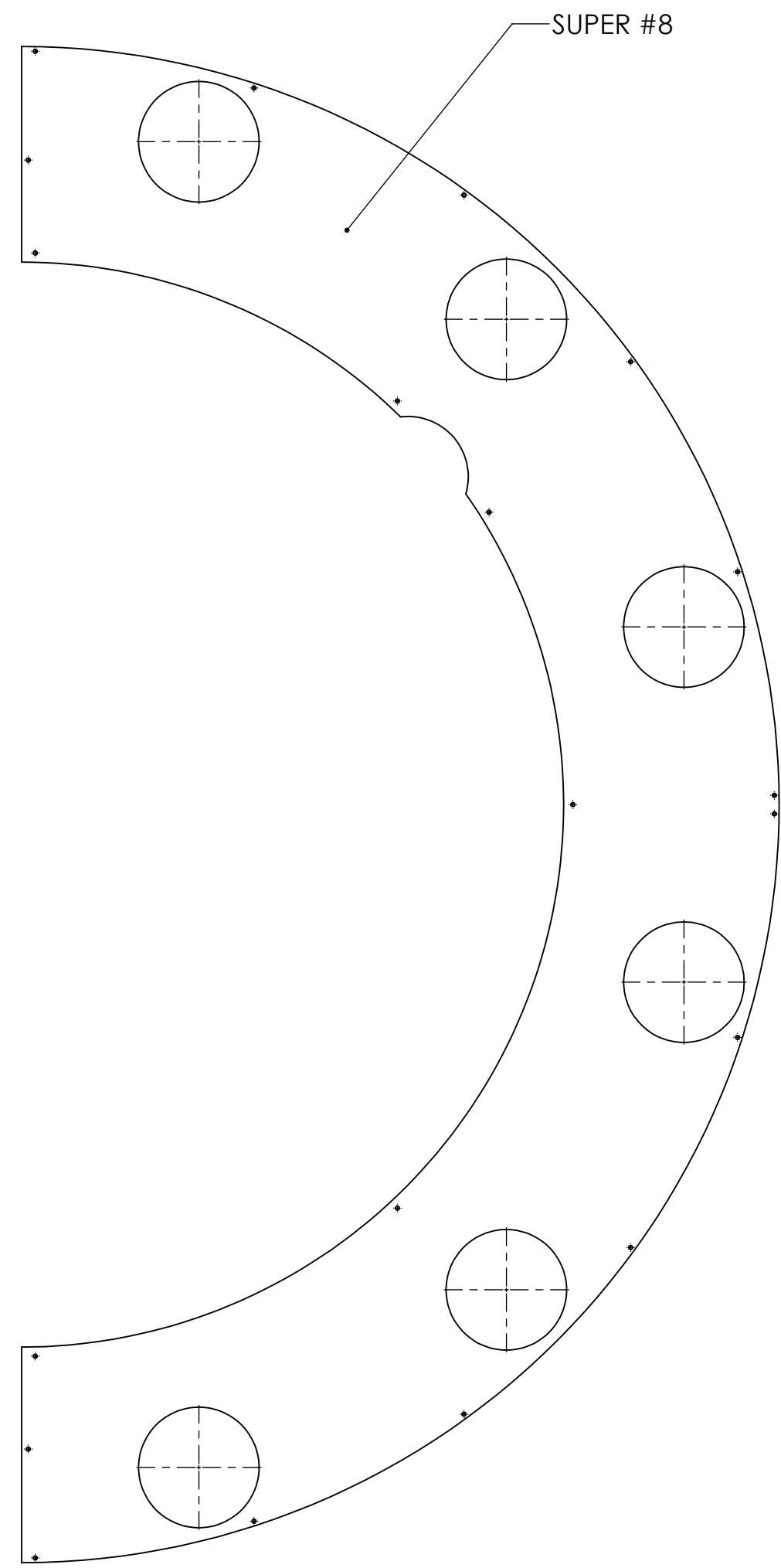

REV.	DATE	DCN #	DRAWING TREE #
v1	22 JUN 2011	E1000822-v2	-
v2	18 JUL 2011	-	-
v3	8 SEP 2011	-	-

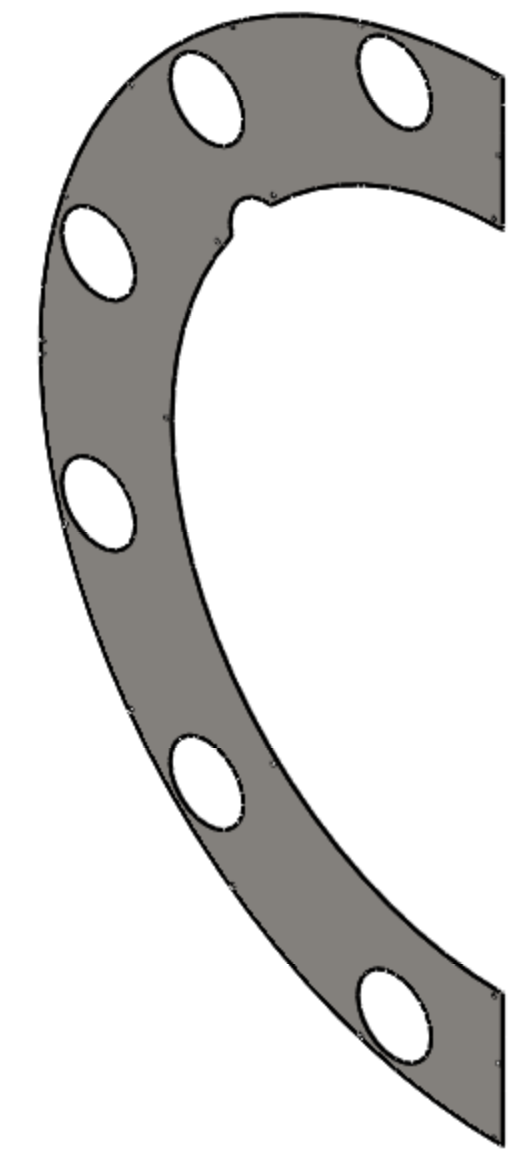

GENERAL VIEW FOR REFERENCE ONLY NO SCALE

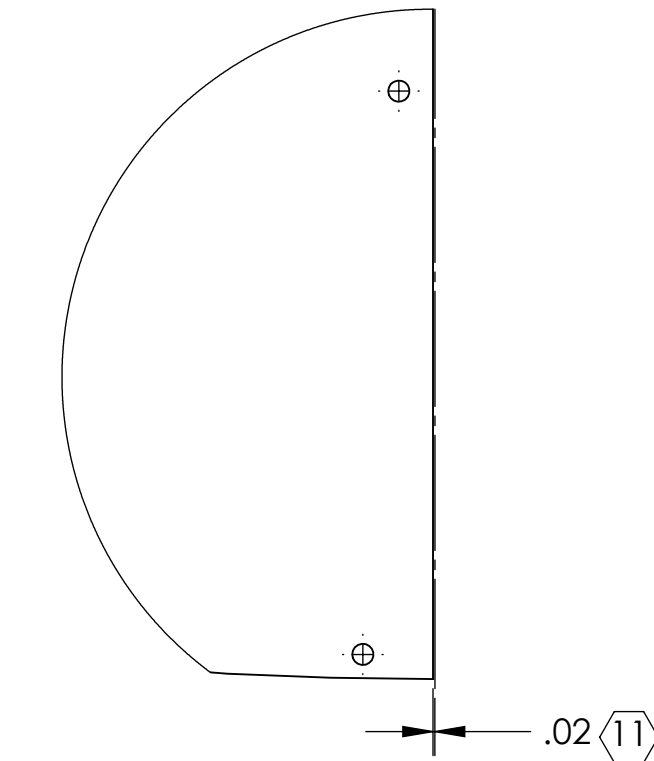

DETAIL A SCALE 1 : 2 2 PLACES

NOTES AND TOLERANCES: (UNLESS OTHERWISE SPECIFIED)				LIGO CALIFORNIA INSTITUTE OF TECHNOLOGY MASSACHUSETTS INSTITUTE OF TECHNOLOGY		PART NAME	
DIMENSIONS ARE IN INCHES				SYSTEM		TUBE BAFFLE PLATE_LOWER-MCA3	
TOLERANCES: .XX ± .02 .XXX ± .005				ADVANCED LIGO		DESIGNER TQ. NGUYEN 17 JUN 2011	
ANGULAR ± 0.5°				SUB-SYSTEM AOS		DRAFTER TQ. NGUYEN 22 JUN 2011	
MATERIAL 18 GAUGE 304 SSSL				NEXT ASSY D1002864		SIZE DWG. NO. D D1101152	
FINISH 8 SUPER #8				APPROVAL D. COYNE		REV. v3	
				SCALE: 1:8		PROJECTION: [Symbol] SHEET 1 OF 2	

D1101152.dwg; JACOBO_Tube_Baffle_Plate_Lower_MCA3; PART PDM REV: X.008; DRAWING PDM REV: X.012

8

7

6

5

4

3

2

1

H

G

F

E

D

C

B

A

H

G

F

E

D

C

B

A

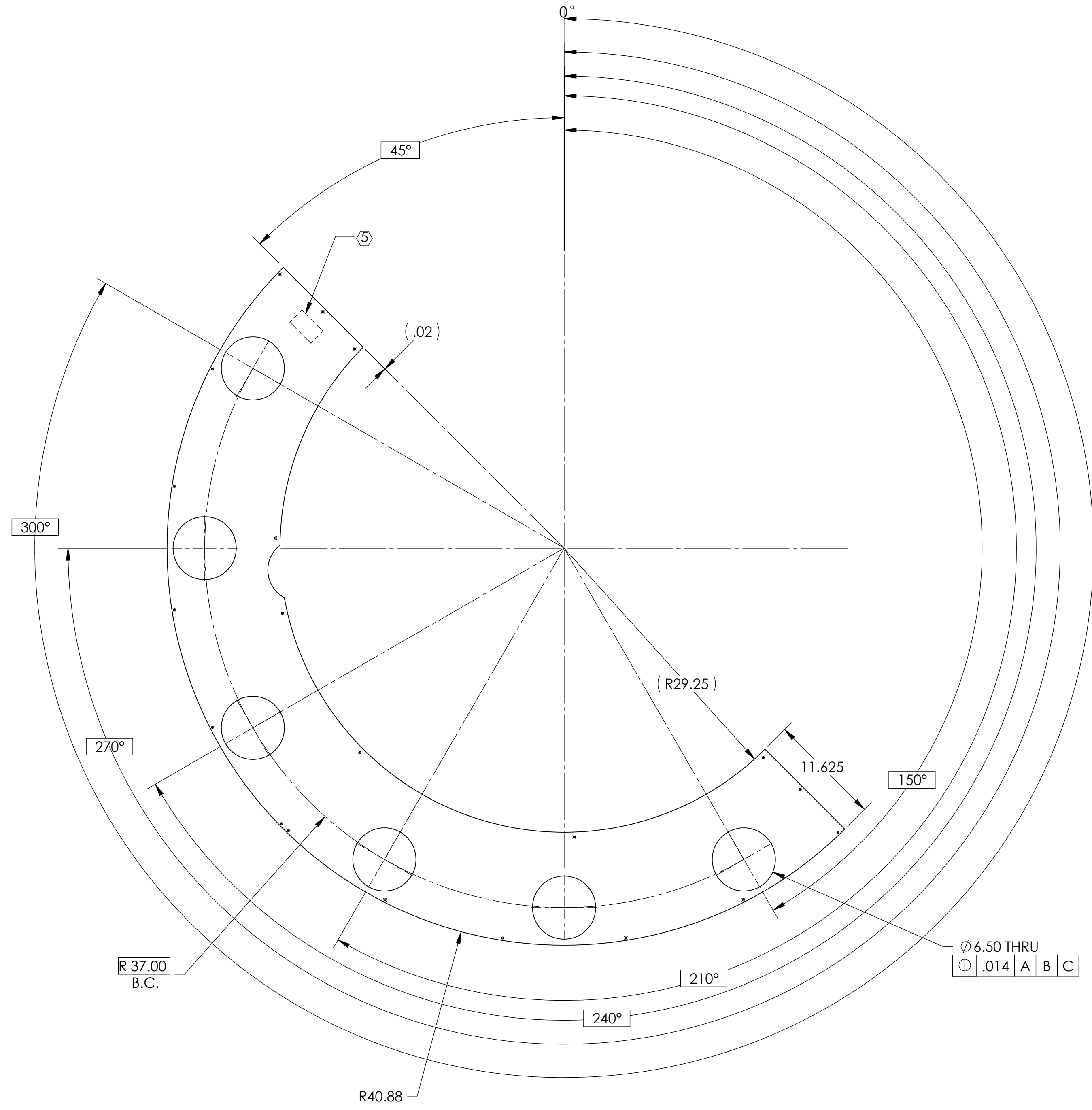

LIGO CALIFORNIA INSTITUTE OF TECHNOLOGY
 MASSACHUSETTS INSTITUTE OF TECHNOLOGY

SIZE	DWG. NO.	REV.
D	D1101152	v3
SCALE: 1:8	PROJECTION:	SHEET 2 OF 2

D:\101152_d1101152_d1101152.dwg: Tube_Baffle_Plate_Lower_JMCA31.PART PDM REV: X.008: DRAWING PDM REV: X.012