

8

7

6

5

4

3

2

1

**NOTES CONTINUED:**

5. SCRIBE, ENGRAVE (A VIBRATORY TOOL MAY BE USED), LASER MARK OR MECHANICALLY STAMP (NO INKS OR DYES) DRAWING PART NUMBER, REVISION (AND VARIANT OR "TYPE" IF APPLICABLE) ON NOTED SURFACE OF PART FOLLOWED ON THE NEXT LINE WITH A THREE DIGIT SERIAL NUMBER. SERIAL NUMBERS START AT 001 FOR THE FIRST ARTICLE AND PROCEED CONSECUTIVELY. USE MINIMUM 0.12" HIGH CHARACTERS, UNLESS THE SIZE OF THE PART DICTATES SMALLER CHARACTERS. EXAMPLE: DXXXXXX-VY, TYPE-XX, S/N XXX

- 6. APPROXIMATE WEIGHT = 13 LB.
- 7. MACHINE ALL SURFACES TO REMOVE OXIDES AND MILL FINISH. USE OF ABRASIVE REMOVAL TECHNIQUES IS NOT ALLOWED. REFER TO LIGO-E0900364
- 8. ALL PARTS SHALL BE MANUFACTURED IN ACCORDANCE WITH LIGO SPECIFICATION E0900364, OR VACUUM EQUIPMENT MANUFACTURER'S SPECIFICATION IF APPROVED BY LIGO.
- 9. ALL MATERIAL IS TO BE VIRGIN MATERIAL (i.e. NO WELD REPAIRS, PLUGS OR RECYCLED MATERIAL). NO REPAIRS SHALL BE MADE UNLESS APPROVED IN ADVANCE, AND IN WRITING, BY LIGO LABORATORY. REFER TO LIGO-E0900364.

MARK PART NUMBER & SERIAL NUMBER ON THIS EDGE. SEE NOTE 5

.397" THRU HOLES  
12 EQUALLY SPACED ALONG 9.13 DIA  
WITH 90 DEG, .38" COUNTERSINK, BOTH SIDES

Ø7.13

MARK THIN STRAIGHT LINE ON THESE SURFACES

REV.	DATE	DCN #	DRAWING TREE #
V1	9 JUN 2011	E1100478-X0	NA
-	-	-	-
-	-	-	-

D

C

B

A

D

C

B

A

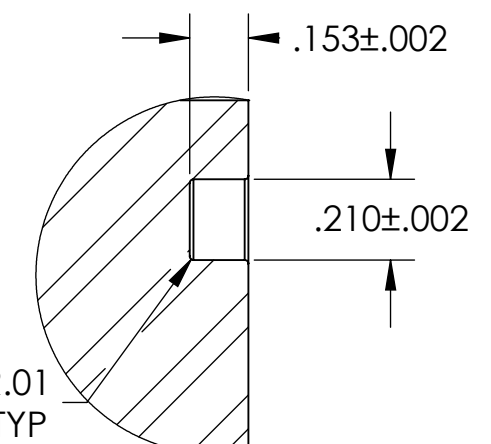
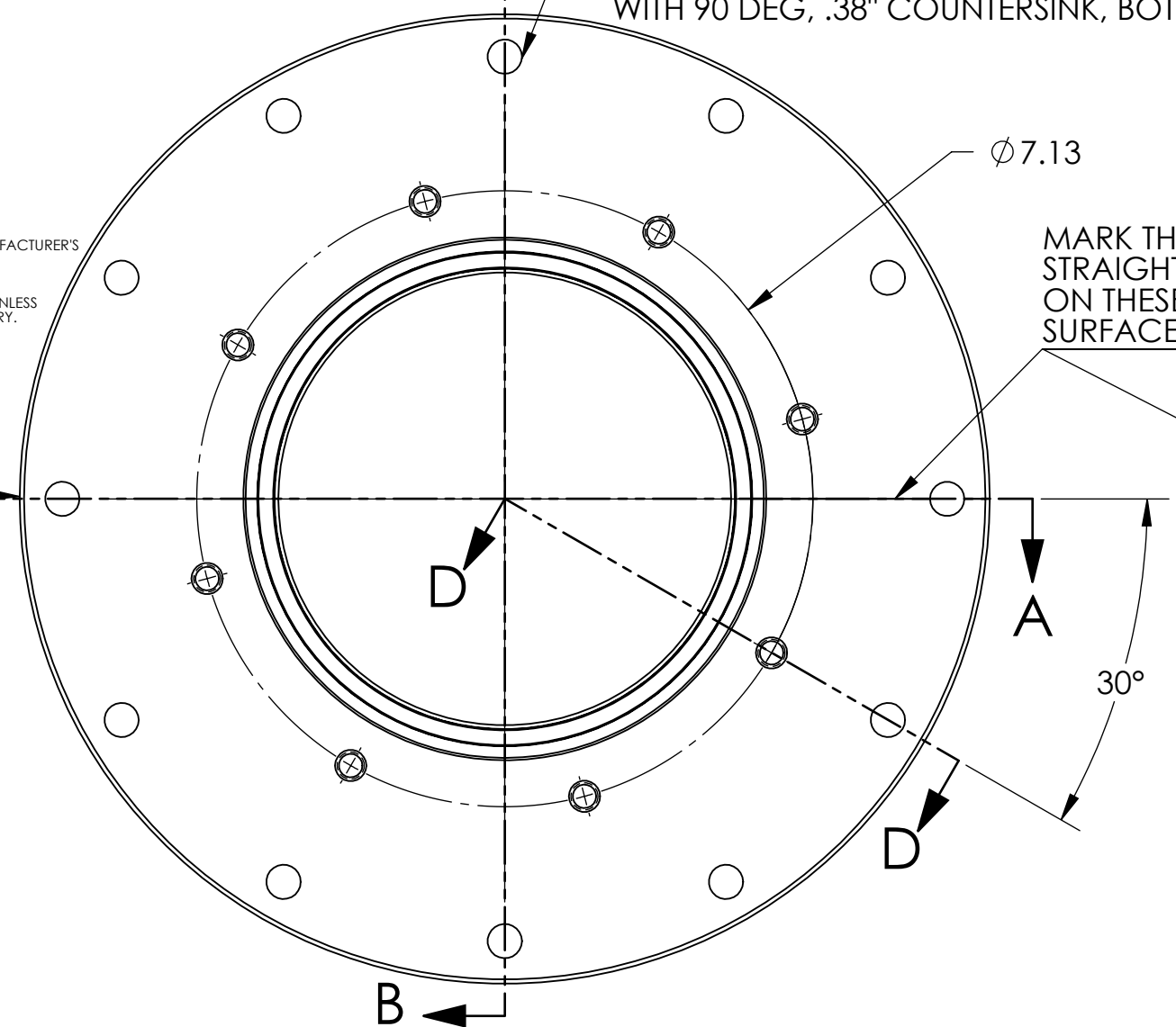

DETAIL E  
SCALE 2:1

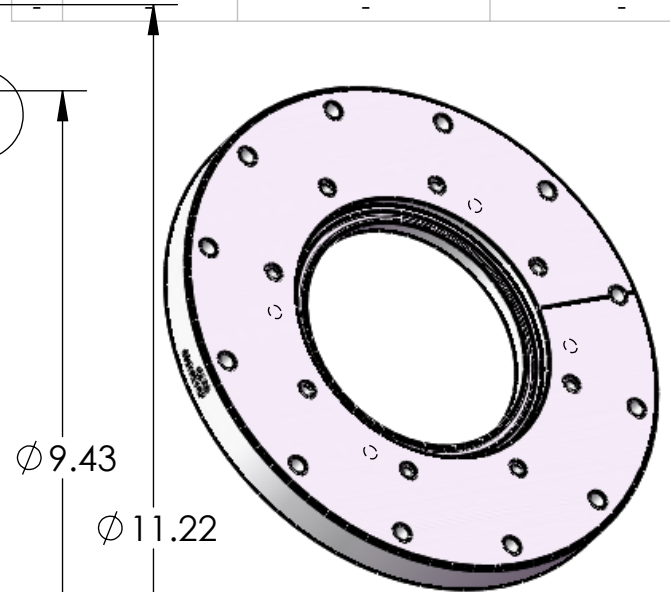

SECTION B-B

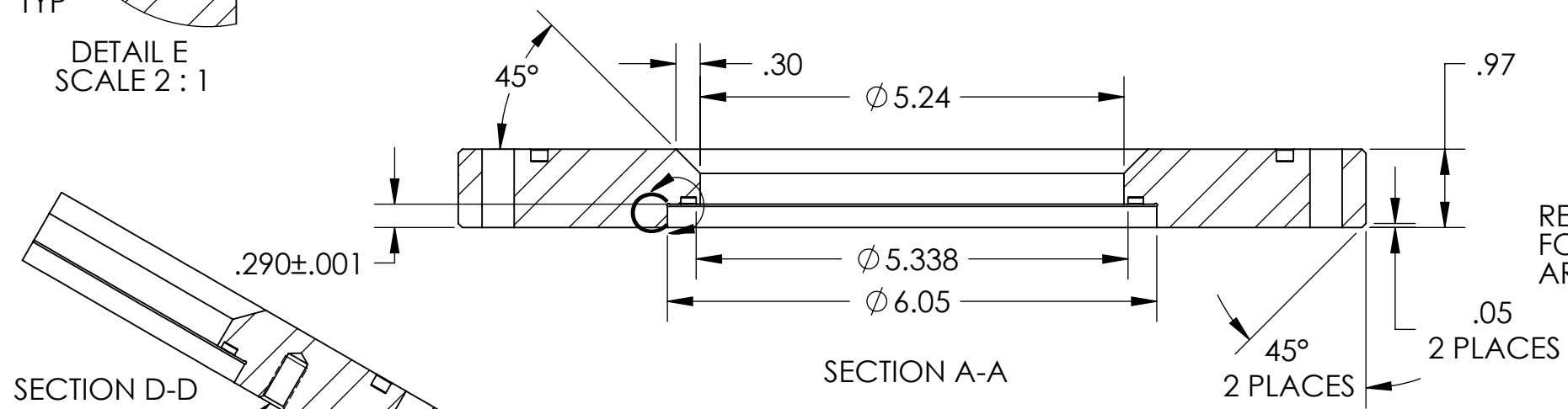

SECTION A-A

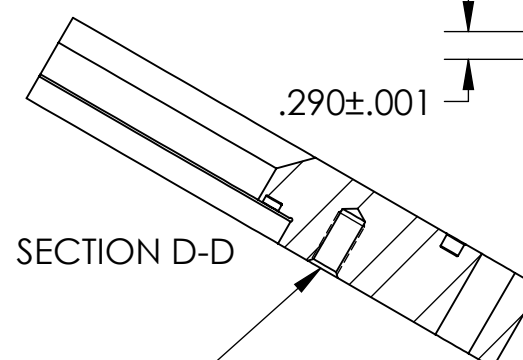

SECTION D-D

5/16-24 TAP .6" DEEP  
DRILL .76" MAX DEPTH  
8 EQUALLY SPACED ALONG 7.13 DIA

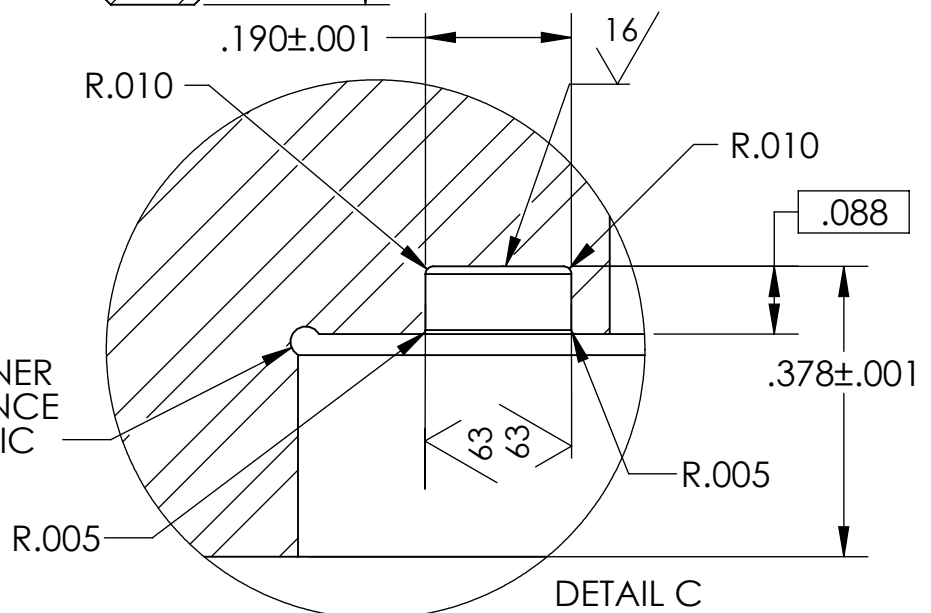

DETAIL C

RELIEVE CORNER FOR CLEARANCE AROUND OPTIC

**NOTES AND TOLERANCES: (UNLESS OTHERWISE SPECIFIED)**

1. INTERPRET DRAWING PER ASME Y14.5-1994.  
2. REMOVE ALL SHARP EDGES, .005-.015, FOR MACHINED PARTS. ROUND ALL EDGES APPROXIMATELY R.02 FOR SHEET METAL PARTS.  
3. DO NOT SCALE FROM DRAWING.  
4. ALL MACHINING FLUIDS MUST BE FULLY SYNTHETIC, FULLY WATER SOLUBLE AND FREE OF SULFUR, SILICONE, AND CHLORINE.

DIMENSIONS ARE IN INCHES

TOLERANCES:  
.XX ± .03  
.XXX ± .010  
ANGULAR ± 1.0°

MATERIAL: AISI 304  
FINISH: 63 Raµinch

CALIFORNIA INSTITUTE OF TECHNOLOGY MASSACHUSETTS INSTITUTE OF TECHNOLOGY		PART NAME	
SYSTEM: AOS		aLIGO Septum Viewport FLANGE	
SUB-SYSTEM: SLC		DESIGNER: Dennis Coyne 9 JUN 2011	SIZE DWG. NO. B
NEXT ASSY: D1101092		DRAFTER: Dennis Coyne 27 May 2011	D1101117
		CHECKER: Mike Smith 8 Jun 2011	REV. v1
		APPROVAL: see DCN	SCALE: 1:2 PROJECTION: SHEET 1 OF 1

D1101117 aLIGO Septum Viewport Flange, PART PDM REV: X-001, DRAWING PDM REV: X-000

8 7 6 5 4 3 2 1