



LIGO Laboratory / LIGO Scientific Collaboration

E1100440-v4

LIGO

27 Nov 2013

**Advanced LIGO HAM Tip-Tilt Suspension
Assembly Procedure**

Bram Slagmolen, Keita Kawabe

Distribution of this document:
Advanced LIGO Project

This is an internal working note
of the LIGO Laboratory.

California Institute of Technology
LIGO Project – MS 18-34
1200 E. California Blvd.
Pasadena, CA 91125
Phone (626) 395-2129
Fax (626) 304-9834
E-mail: info@ligo.caltech.edu

Massachusetts Institute of Technology
LIGO Project – NW22-295
185 Albany St
Cambridge, MA 02139
Phone (617) 253-4824
Fax (617) 253-7014
E-mail: info@ligo.mit.edu

LIGO Hanford Observatory
P.O. Box 1970
Mail Stop S9-02
Richland WA 99352
Phone 509-372-8106
Fax 509-372-8137

LIGO Livingston Observatory
P.O. Box 940
Livingston, LA 70754
Phone 225-686-3100
Fax 225-686-7189

Table of Contents:

1. Introduction.....	3
1.1. Clean room standards.....	3
1.2. Torque Values for Bolts:.....	3
1.3. Assembly Report.....	3
2. Assembly and sub-assemblies preparation	4
2.1. Bill of Material.....	4
2.2. BOSEMs	4
2.3. Tools	4
2.4. Parts for pre-balancing.....	4
3. Assemble Structure	6
3.1. Step 1 – Base, Side and Top	7
3.2. Step 2 - Backplane	8
3.3. Step 3 – BOSEMs	9
3.4. Step 4 – Finalizing	11
4. Assemble Blades.....	14
4.1. Step 1 – Base, Hinge and Pitch Adjuster	14
4.2. Step 2 – Blade and Damper	16
4.3. Step 3 – Stopper	18
4.4. Step 3 – Finalizing	18
5. Assemble Mirror Holder	19
5.1. Inner Wire Clamp Magnet Assembly	19
5.2. PEEK Flag Assembly	19
6. Assemble Suspension Wire.....	20
7. Assemble Suspending Mirror	21
8. Pre-Balancing.....	21
9. Finalising the Assembly.....	22
10. Appendix A. Torque Specifications (Generic SS).....	24

1. Introduction

This document details the assembly of D1001396 Advanced LIGO HAM Tip-Tilt Suspension. These instructions are intended to complement the assembly drawings, which can be found on the LIGO Document Control Center.

Before bolting parts together, always make sure there is no dust or debris in the interface.

This introduction summarizes very important information for the assembly. It recalls the clean room standards, gives information on torque values, hardware, and describes the overall assembly documentation.

1.1. Clean room standards

For a clean assembly all LIGO standards should be followed, as presented in the latest version of the **LIGO Contamination Control Plan (E0900047)**. Clean room garb including UHV gloves should be worn when working with parts.

All tools that come in contact with assembly should be cleaned to class B standards.

Assembly will be done under a portable clean room. Any time a part of the assembly is not covered by the portable clean room or not being actively worked on it should be covered with appropriate clean covers. (C3 polyester or equivalent).

All parts that will be included in the final assembly must be cleaned to LIGO standards, Class A. The list of parts to be Class A-cleaned includes screws, washers, inserts, and assorted other hardware. All tooling and other parts that are not included in the final assembly, but that contact Class A parts during assembly must be cleaned to LIGO standards, Class B.

1.2. Torque Values for Bolts:

Except where noted, use a torque wrench to tighten all screws to specified torques.

[Torque values are provided in blue](#)

Table of torque values are also given in appendix D, which is an abstract from document T1100066 of the SSSL Generic torque values.

1.3. Assembly Report

During assembly of the HAM Tip-Tilt Suspension various steps and values are recorded in the Assembly Report (F1100007). In this report a final DCC number for the assembly will be filed as an E document.

During the assembly it is mentioned to record the serial number of the various parts in the Assembly Record, this is highlighted in red.

2. Assembly and sub-assemblies preparation

2.1. Bill of Material

The BOM is listed on the top overview drawing, ‘aLIGO Tip-Tilt Mirror Assembly - [D1001396](#)’

2.2. BOSEMs

The HAM Tip-Tilt Suspension uses the D060218-v1 Birmingham OSEM assemblies (BOSEM). The BOSEM will be partially disassembled for the removal of D060107 Backplate and D060108 Clamp. Keep the four (4) little socket head cap screws which held the Backplate in place and the two (2) adjuster shafts with their PEEK nuts for reuse.

2.3. Tools

The following lists the tools required (and provided) to fully assemble the HAM Tip-Tilt Assembly.

- (2x) Torque wrench: 2.5 In-lbs to 75.2 In-lbs
- (2x) Allan Keys (L-shape + for wrench):
 - 0.050
 - 1/16
 - 5/64
 - 3/32
 - 9/64
 - 5/32
 - 3/16
- (2x) Spanner: 9/32" (A/F?)
- (2x) Shifter: 4" and 6"
- (3x) Socket drive (~1.25" deep): 9/32" (A/F?)
- (2x) Screw driver: 5/32" width
- (2x) Wire cutter (for 127um or 0.005" steel wire)
- (2x) Ruler (inches + metric): 1ft
- scratch or engrave tool, for marking an 'X', 'N' or 'S' on PEEK and magnet coating

2.4. Parts for pre-balancing

- (1x) 2" diameter, 3/8" thick mirror.
- (1x) laser pointer.
- (1x) holder for laser pointer at 4", with the ability to level the laser pointer
- (1x) vertical ruler or post at 4" (or equivalent).
- (1x) level workbench

Only when required

- (1x) scalpel

After each HTTS unit is assembled, it is balanced with a dummy optic to make sure that everything is good mechanically. Only use a 3/8" thick mirror, if pre-balanced with a 1/2" optic, it will be impossible to balance it properly with a real optic later.

The 2" mirror is secured using a small round piece PTFE ('mirror nudge'), which is in turn held in place with a #4 set screw. It is possible that the mirror nudge is too thick, and makes it hard to insert and remove the mirror. Before you insert the optic, use a scalpel to thin down the mirror nudge. Start on one side first, and work your way around until the mirror nudge slide into the opening.

3. Assemble Structure

Drawings: [D1100906](#) aLIGO HAM Tip-Tilt Suspension Assembly – Structure.

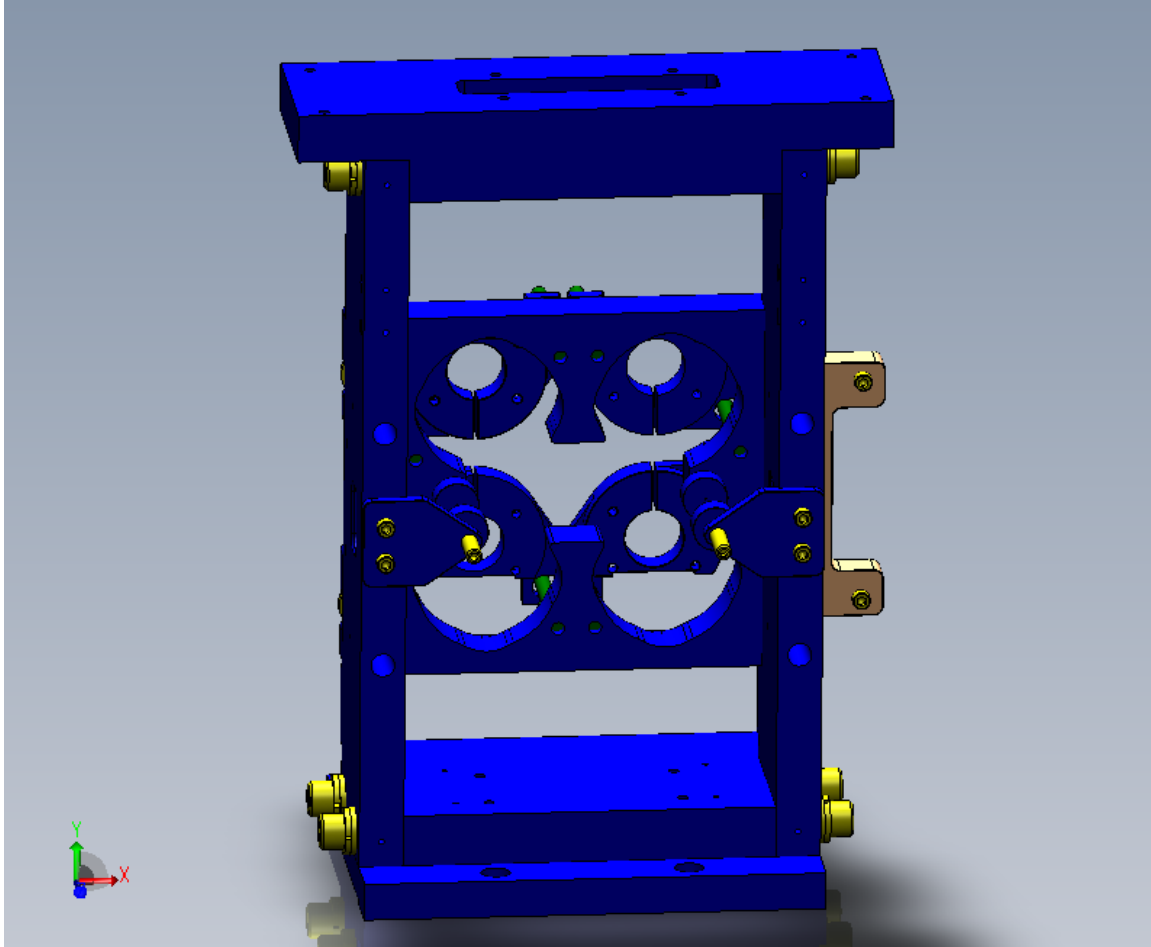

Figure 1. Overall Tip-Tilt Structure Assembly.

Parts required

QTY	Part Number	Description
1	D1000768 v2	Tip-Tilt Structure Base
2	D1000772 v2	Tip-Tilt Structure Side
1	D1000767 v2	Top Plate, Opposite $dy=35\text{mm}$
1	D1001450 v2	Tip-Tilt BOSEM Backplane
2	D1001496 v1	Tip-Tilt BOSEM Backplate - Upper Right
2	D1001511 v1	Tip-Tilt BOSEM Backplate - Upper Left
4	D060218	Birmingham OSEM assemblies
1	D1001484 v1	Tip-Tilt DSUB Bracket
1	D1101430 v1	Tip-Tilt DSUB Bracket Holder
2	D1001492 v2	Tip-Tilt Structure ECD Bracket

4 D1100346 v1 Tip-Tilt Mirror Holder ECD

Fasteners

QTY	Part Number	Description
8	Socket Haed Cap Screw 1/4-20x7/8	
4	Socket Haed Cap Screw 1/4-20x3/4	
8	Socket Head Cap Screw #4-40x0.4375	
2	Socket Head Cap Screw #4-40x0.3125	
12	Flat Washer Type B Narrow 1/4	
2	Flat Washer Type B Narrow #4	
4	Socket Set Screw Oval Point #8-32x1	
2	Socket Set Screw Oval Point #4-40x0.25	

3.1. Step 1 – Base, Side and Top

Select the (1x) Structure Base, (2x) Structure Side and (1x) Top Plate, Opposite dy=35mm. *Record their serial numbers on the Assembly Report.*

Starting with the Base, mount the two Side's as shown in figure 1, using the 1/4"-20x7/8 SHCS (4x). Place the 'wider' end of the Side's, which have the two larger chamfers, onto the Base. Orientate the chamfers to the back of the Base, so the front of the Side's and the Base are aligned, as shown in Figure 2.

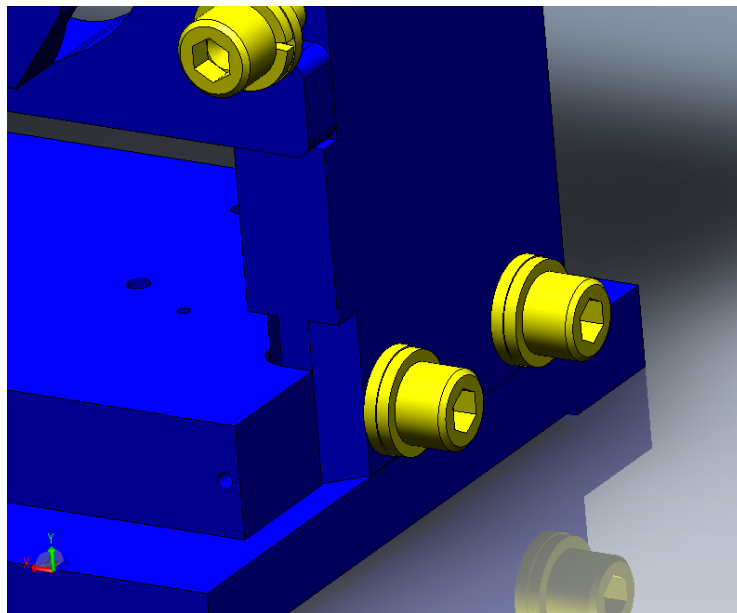

Figure 2. Chamfer located at the back. Shown is the use of lock-washers (the washer underneath the screw head), they are NOT installed.

Use the only a flat washer, leave the screw loose for now. No lock-washer (or spring washer) are NOT used in any part of the HTTS assembly.

Place the Top Plate on top with the engraving to the front (and the two tapped holed at the back), as shown in figure 1, and use the remainder of the $\frac{1}{4}$ "-20x7/8 SHCS (4x), with a flat washer.

In figure 1, the Base and the Top are in a lighter color, into which the screws are inserted.

Once all screws are in place use the **75.2 in-lb** on the torque to tighten all screws (8x).

3.2. Step 2 - Backplane

Locate the BOSEM Backplane and insert it from the back. *Record the serial number on the Assembly Report.*

The back of the structure is identified by the small step on the Side's. Place/insert the Backplane between the Side's on top of this step, such that the U-shape holes align with the screw holes in the Side's. This is illustrated in figure 3, with the Side's shown in a lighter color.

Use the $\frac{1}{4}$ "-20 x 3/4 SHCS (4x) and flat washers to tighten the Backplane, using **75.2 in-lb** of torque.

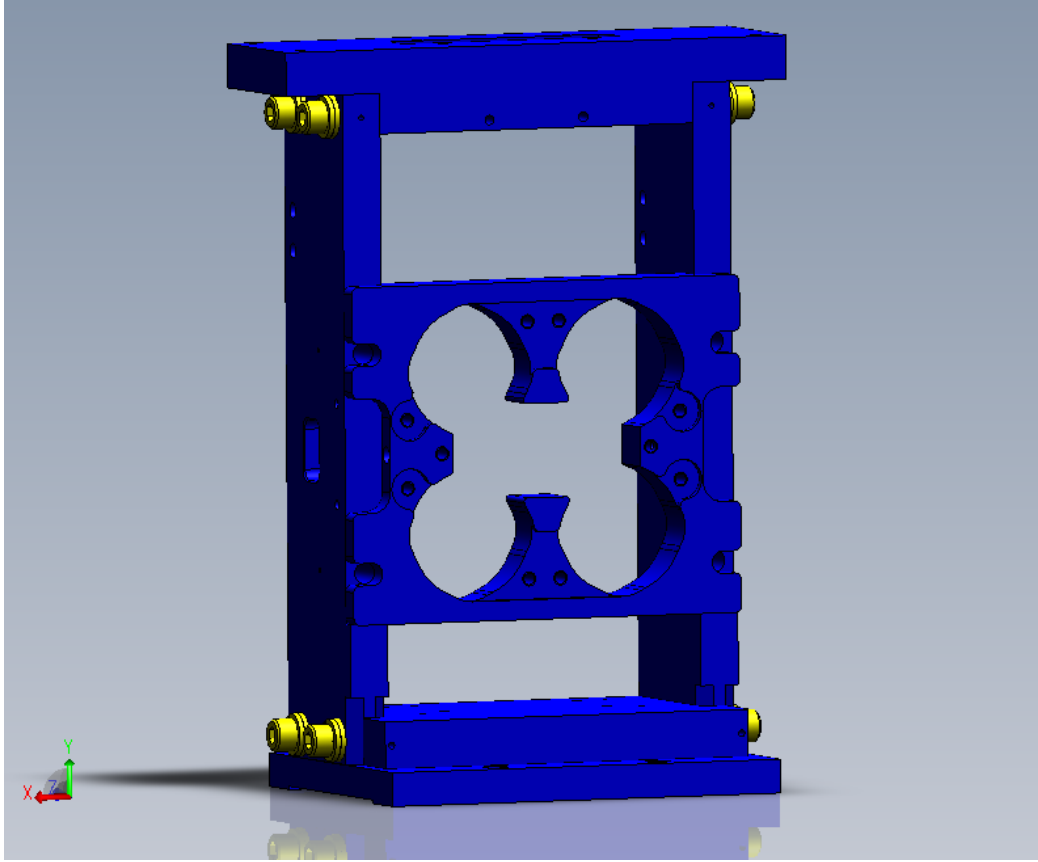

Figure 3. Inserting the Backplane. Shown are the use of lock-washers (the washer underneath the screw head), they are NOT installed.

3.3. Step 3 – BOSEMs

Select (4x) BOSEMs. Take one BOSEMs and unscrew the Coil Former (with all the electronics) from the Clamp via the Adjuster Shafts using the two PEEK nuts. When separated, unscrew the Adjuster shafts form the Clamp. Remove the Backplate from the Coil Former via the 4 socket hard cap screws on the back, shown in figure 4. Place the Clamp and the Backplate back in the bag.

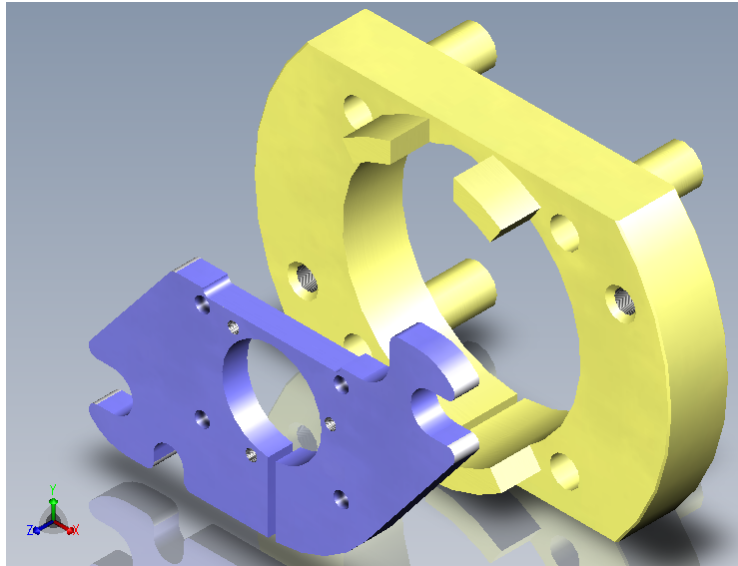

Figure 4. Discarded BOSEM parts.

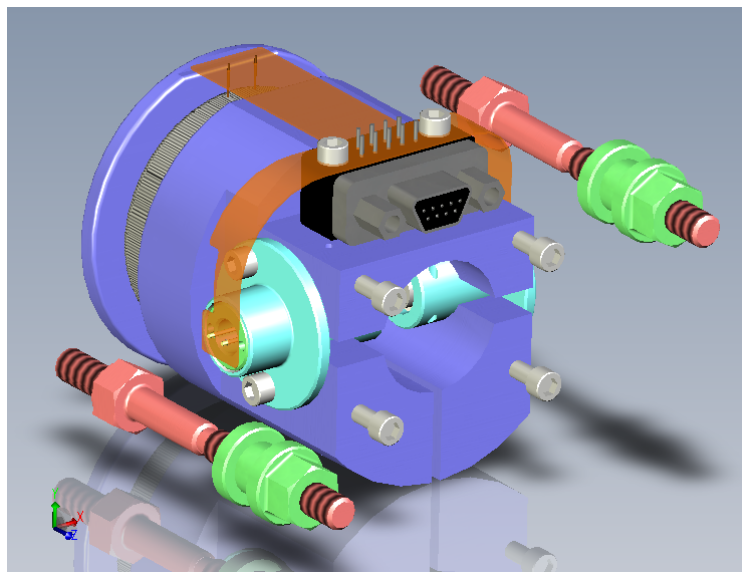

Figure 5. Reminder parts, with the two 'red' Adjuster Shafts and the two 'green' PEEK nuts.

Screw in the Adjuster Shafts in to the Backplane (from step 2), as shown in figure 6 (total of 8x), with a torque of **19.8 in-lb**.

Select (2x) BOSEM Backplate - Upper Right, and (2x) BOSEM Backplate - Upper Left. *Record their serial numbers on the Assembly Report.* Using the original four little BOSEM screws and mount the Backplates onto the 4 BOSEMs.

Using the original two (2) Nuts, insert the BOSEM's into the Tip-Tilt Backplane. Orientate the BOSEM's such that the 9-pin MicroD connectors are on top for the UPPER BOSEMs and at the bottom for the LOWER BOSEMs.

Screw in the BOSEM's so that the front of the BOSEMs are flush with the backplane (this is quite an exercise). Record the serial number of the BOSEM in the location as listed in F1100007.

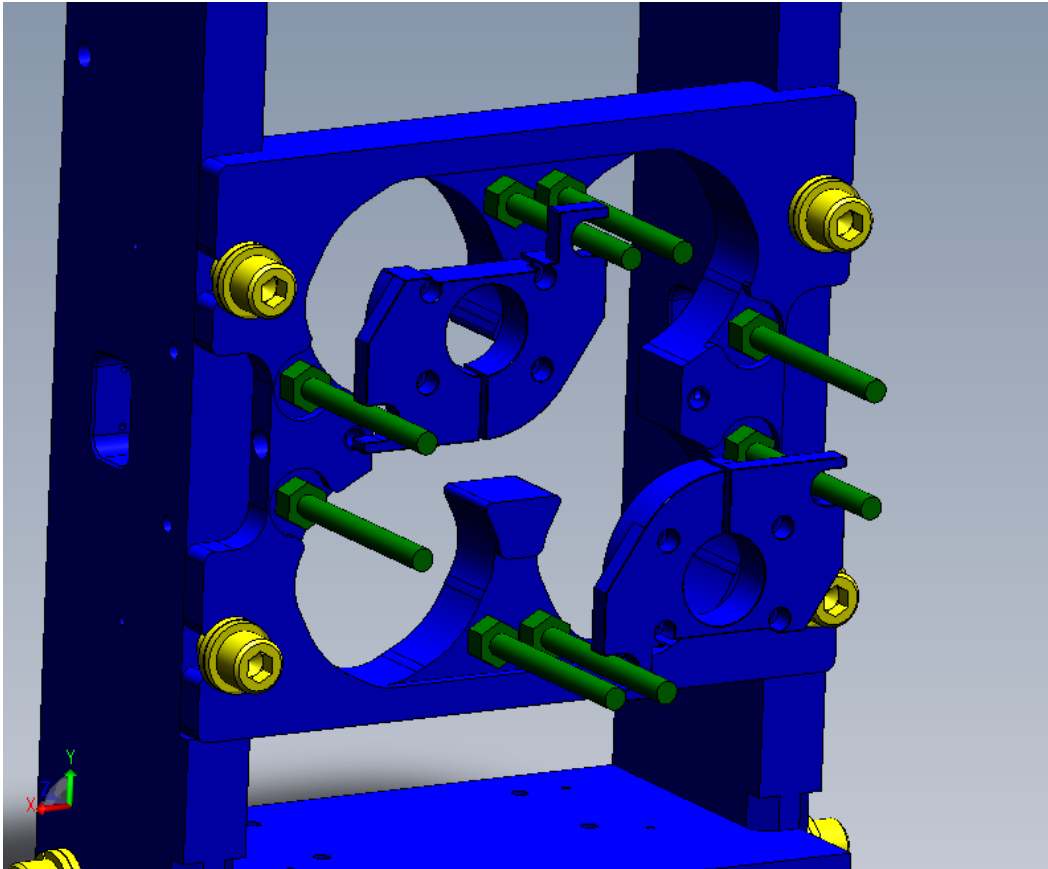

Figure 6. Adjuster Shaft installation. Shown are the use of lock-washers (the washer underneath the yellow screw head), they are NOT installed.

3.4. Step 4 – Finalizing

Select (2x) Structure ECD Bracket, (4x) Mirror Holder ECD, (4x) Titanium Socket Set Screw Oval Point #8-32x1, (2x) PEEK Nut #8 and (2x) Socket Set Screw Oval Point #4-40x0.25.

Screw the 1" Titanium Set Screws into the Mirror Holder ECD, as shown in figure 7.

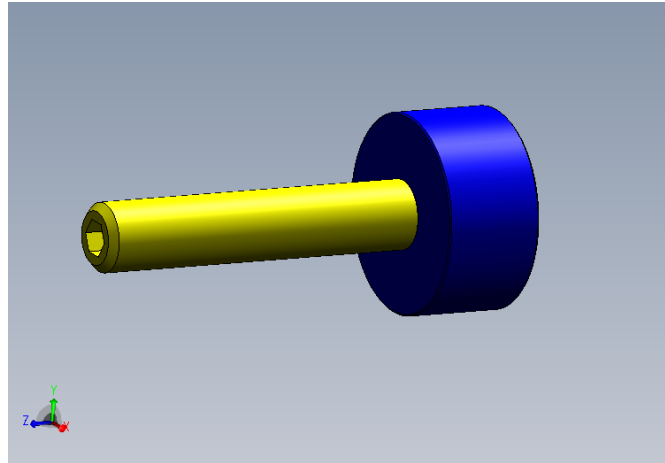

Figure 7. Titanium Set Screw and Mirror Holder ECD.

Screw (2x) of the Titanium Set Screw assemblies in to the Backplane as shown in Figure 8. Use the (2x) #4-40 x 0.25 Set Screws to lock the #8-32 into place.

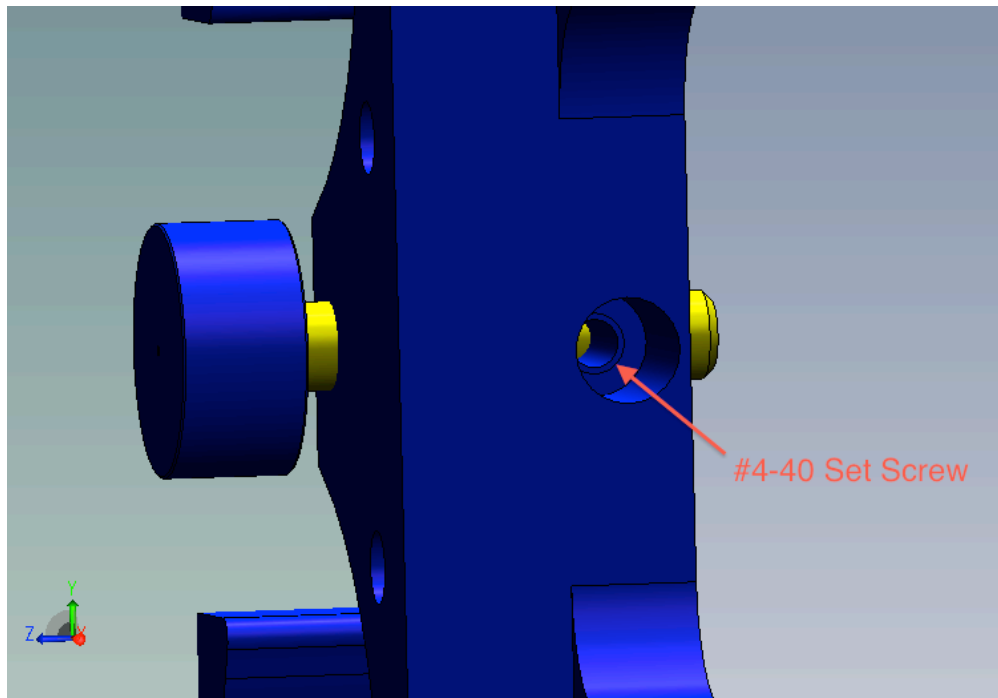

Figure 8. Set Screw Assembly into Backplane.

Assemble the left over two Titanium Set Screw Assemblies into the ECD Baskets and mount them onto the Side's as shown in Figure 9. Using (2x) #4-40 x 0.4375 with **5.2 in-lb** torque.

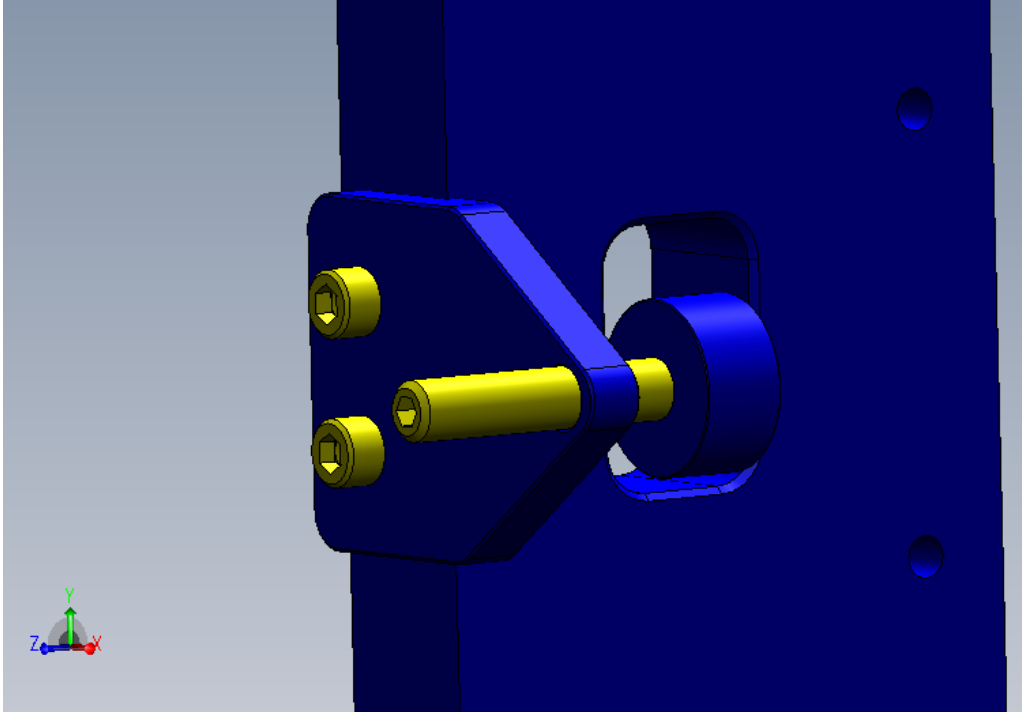

Figure 9. Mirror ECD mounted in the bracket onto the Side.

Mount the DSUB Bracket to the D1101430 DSUB Bracket Holder on the narrow side using (2x) #40-40 x 0.3125. Then mount the DSUB Bracket Holder to the baseplate using (2x) #4-40 x 0.4375 SHCS and (2) #4 type B narrow flat washers. Use two threaded holes located at the 'back' on the baseplate and the slotted holes in the Bracket Holder, with the DSUB Bracket facing upwards, as shown in Figure 10.

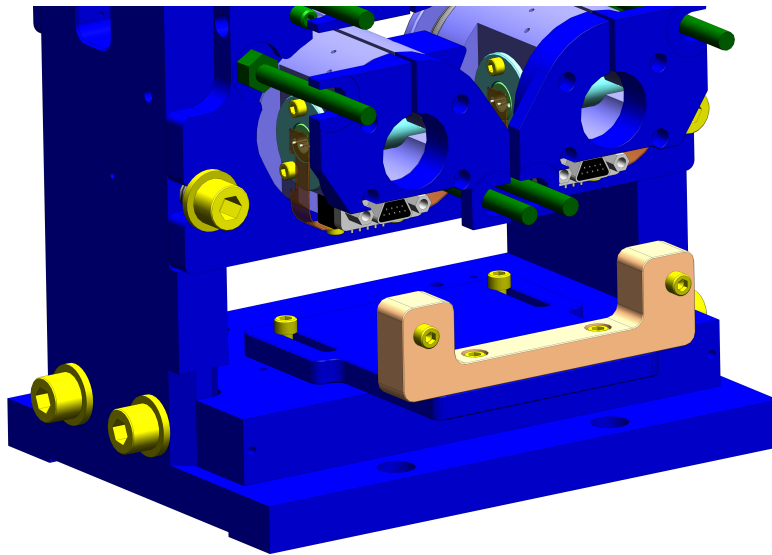

Figure 10. Mounting the DSUB Bracket.

4. Assemble Blades

Drawings: aLIGO HAM Tip-Tilt Suspension Assembly – Blades ([D1100913](#))

There will be two (2x) of the aLIGO HAM Tip-Tilt Suspension – Blade assemblies required for a single HAM Tip-Tilt Suspension.

Parts required

QTY	Part Number	Description
1	D1000766 v1	Tip-Tilt Base Pitch Adjuster
1	D1000810 v1	Tip-Tilt Blade Hinge Plate
1	D1002226 v1	Tip-Tilt Pitch Adjuster - 8 deg
1	D1000765 v2	Tip-Tilt Blade 254um
1	D1002227 v1	Tip-Tilt Blade O-ring Spacer
1	D1002228 v1	Tip-Tilt Blade O-ring Ledge
1	D1100345 v1	Tip-Tilt Blade Damping O-ring - BS013
1	D1001480 v1	Tip-Tilt Blade Clamp
1	D1001485 v1	Tip-Tilt Blade ECD Riser
1	D1001486 v1	Tip-Tilt Blade ECD Holder
1	D1001491 v1	Tip-Tilt Blade ECD Screw
1	D1001451 v1	Wire Clamp - Blade Tip
1	D1001481 v1	Tip-Tilt Wire Clamp Top - Blade Tip

Fasteners

QTY	Part Number	Description
1		Socket Button Head Cap Screw #4-40x0.125
2		Socket Button Head Cap Screw #2- 56x0.188
2		Socket Head Cap Screw #8-32x0.5
10		Socket Head Cap Screw #4-40x0.4375
6		Socket Head Cap Screw #4-40x0.3125
1		Hex Thick Nut 1/4
1		Flat Washer Type B Narrow #4
2		Flat Washer Type B Narrow #8

4.1. Step 1 – Base, Hinge and Pitch Adjuster

Select the (1x) Base Pitch Adjuster, (1x) Hinge Plate and (1x) Pitch Adjuster – 8 deg.
Record their serial numbers on the Assembly Report.

Using the (6x) #4-40 x 0.3126 SHCS, mount the Hinge Plate to the Base and Pitch Adjuster as shown in Figure 11. Don't use any washers and use [5.2 in-lb](#) torque.

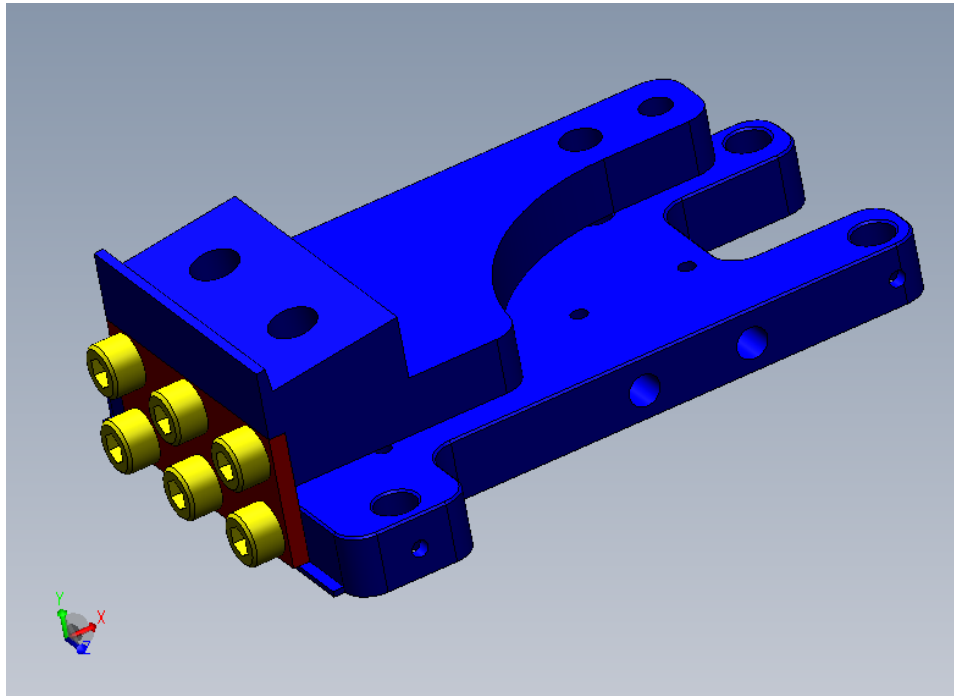

Figure 11. Pitch Adjuster, Base and Hinge Plate.

Insert the (2x) #4-40 x 0.4375 SHCS such that the hinge is at its nominal position, as shown in Figure 12.

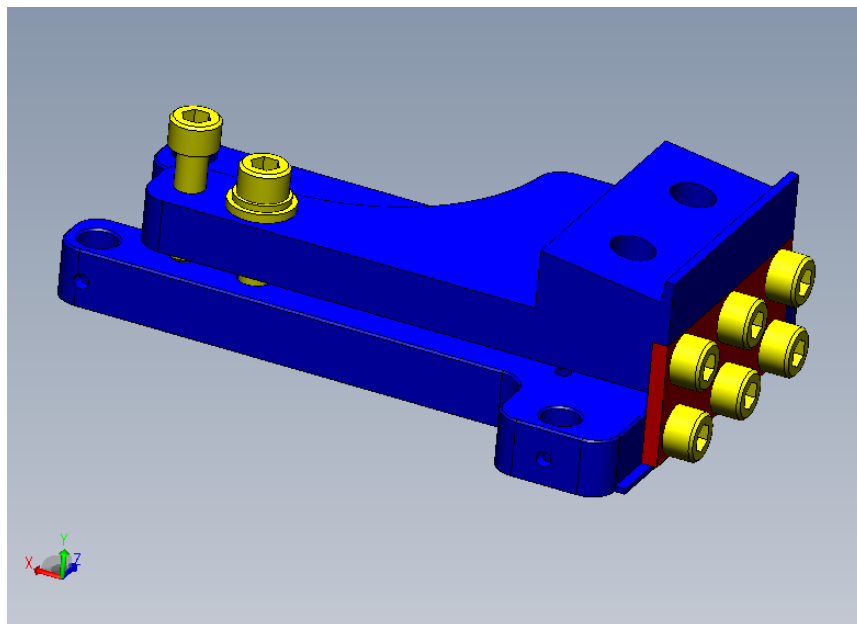

Figure 12. Hinge locking screws. Shown is the used of a lock-washer, on the second screw from the left. This is NOT installed.

4.2. Step 2 – Blade and Damper

Select the (1x) Blade 254 um, (1x) Blade O-ring Spacer, (1x) Blade O-ring Ledge, (1x) Blade Damping O-ring – BS013 and (1x) Blade Clamp. Also select (2x) #8-32 x 0.5 SHCS, including washers.

This is a tricky assembly, to located the O-ring in between the to blades. Figure 13 and 14 show the location of the Ledge and the O-ring. Place the O-ring in the centre of the Ledge, touching the Spacer.

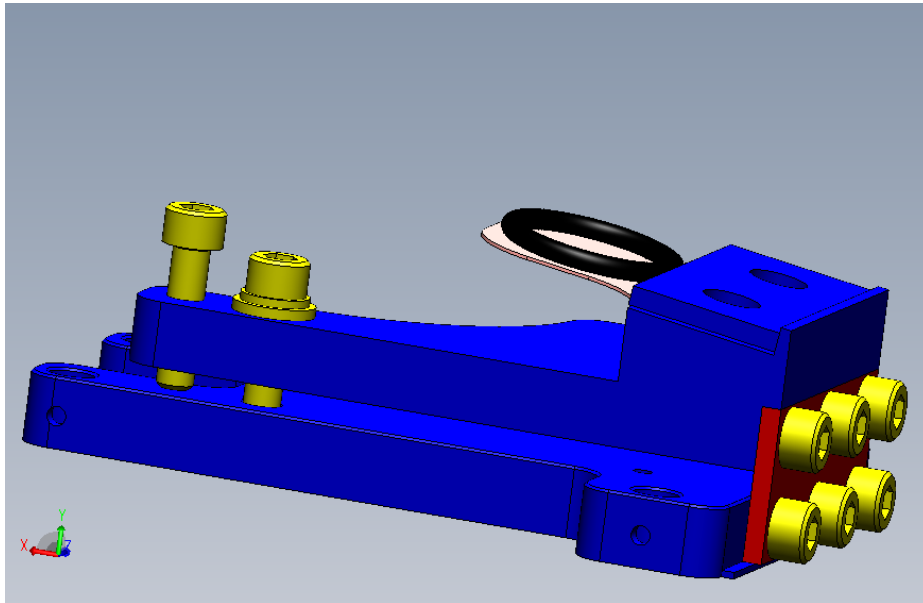

Figure 13. Overall Ledge, O-ring and Spacer location.

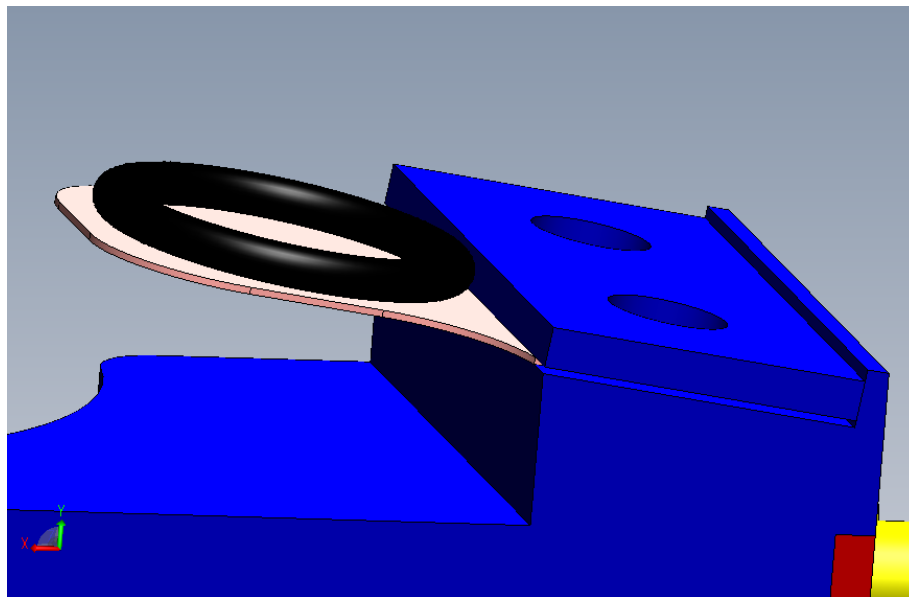

Figure 14. Detail of the Ledge and O-ring, with the reference plane at the back.

Place the Clamp and the two screws and washers as shown in Figure 15. Keep the screws loose (~1 mm spacing) and insert the blade between the Spacer and the Clamp. Keep the Ledge, Spacer, Blade and Clamp tight to the back step on the Pitch Adjuster. This is shown in more detail in Figure 16.

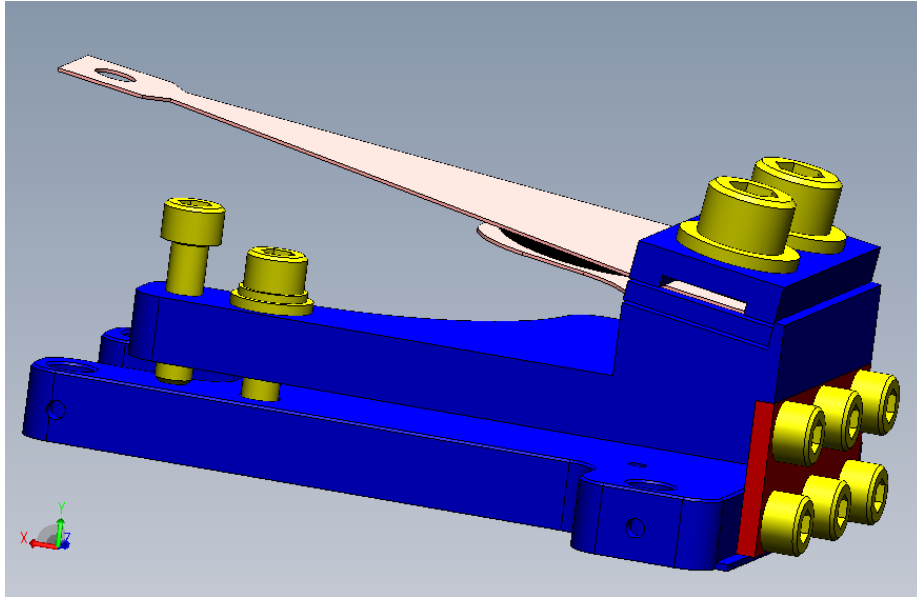

Figure 15. Blade and damper clamped.

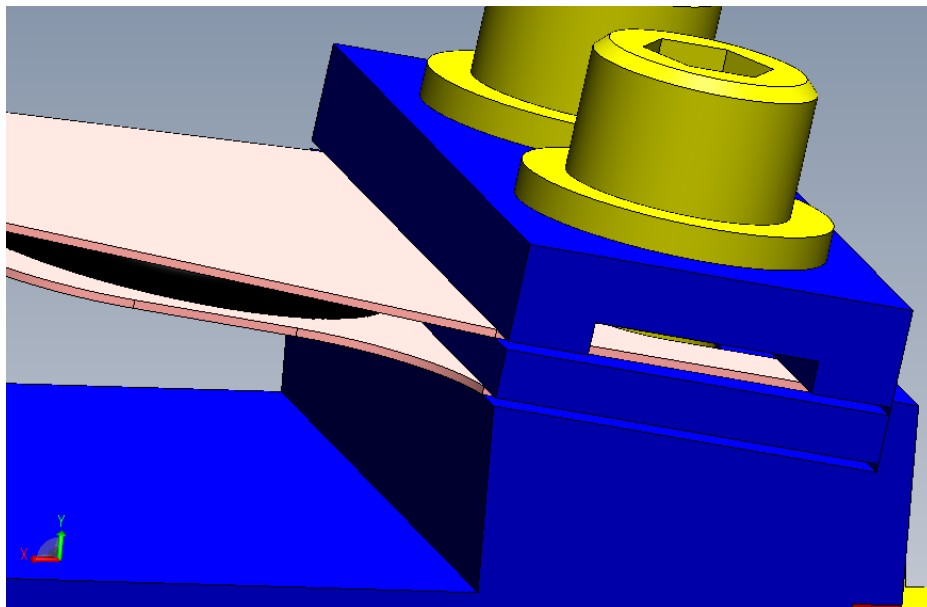

Figure 16. Details of the Ledge, Spacer, Blade and Clamp onto the step on the Pitch Adjuster.

When tighten the #8-32 screws make sure the Blade is against the step, and not on top!
Use the appropriate torque [19.8 in-lb](#).

4.3. Step 3 – Stopper

Select the (1x) Blade ECD Riser, (1x) ECD Holder, (1x) ECD Screw, (1x) ¼” Nut and (4x) #4-40 x 04375 SHCS.

Insert the ECD Screw into the ECD Holder keeping ~2 mm spacing between the ECD Screw head and the ECD Holder. Lock the ECD Screw with the ¼” Nut in place. Mount the ECD Riser to the Base Pitch Adjuster, as shown in Figure 17 using the #4-40 and [5.2 in-lb](#) torque.

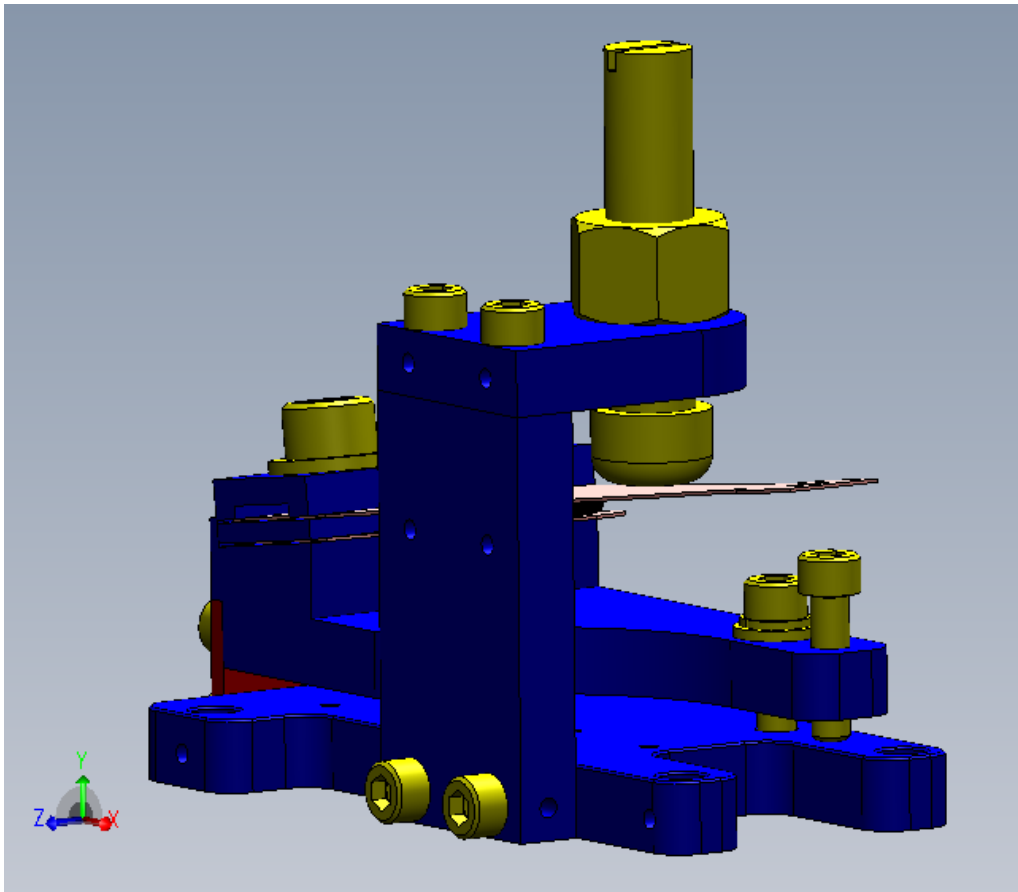

Figure 17. Blade Stopper.

4.4. Step 3 – Finalizing

Check if the O-ring is still in place (e.g. centered on the Ledge).

Set aside and assemble a second Blade Assembly, required for a single HAM Tip-Tilt Suspension.

5. Assemble Mirror Holder

Drawing:

1. aLIGO HAM Tip-Tilt Suspension Assembly - Mirror Holder ([D1100907](#)).
2. Tip-Tilt Flag Magnet Assembly Tool ([D1100862](#))
3. aLIGO HAM Tip-Tilt Inner Wire Clamp Magnet Align Tool ([D1100914](#))
4. aLIGO HAM Tip-Tilt Suspension Magnet Flag Pin ([D1100916](#))

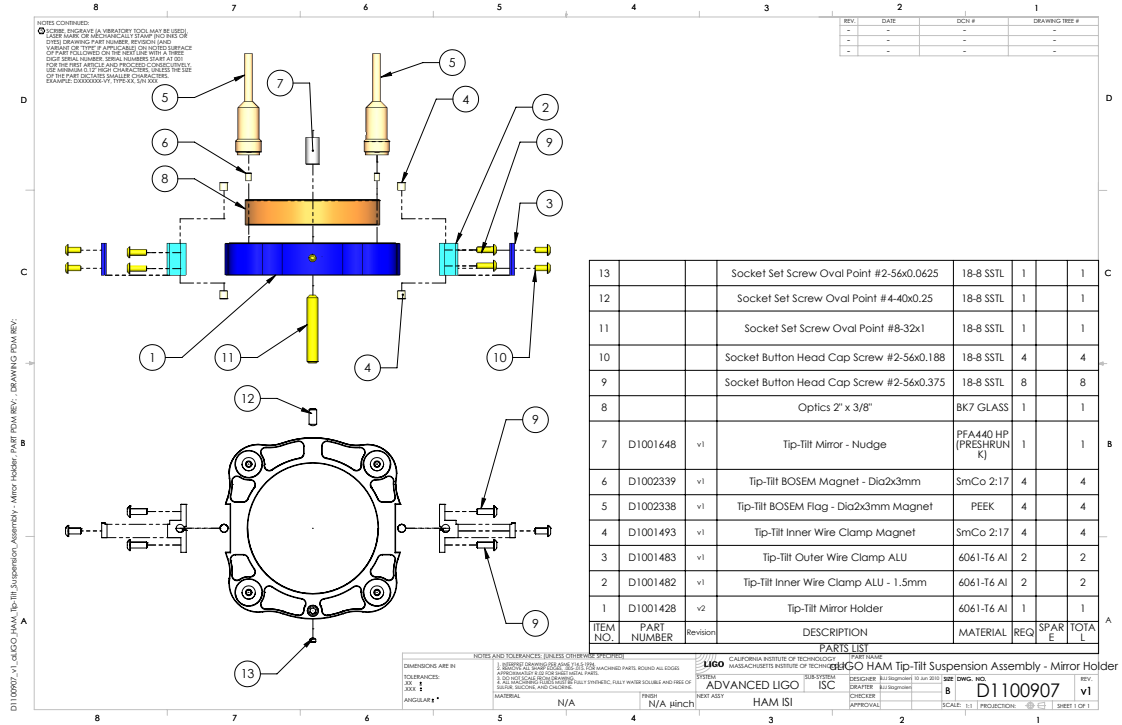

Figure 18. D1100907 Mirror Holder Assembly.

5.1. Inner Wire Clamp Magnet Assembly

Assemble the ‘Inner Wire Clamps’ (2), using the ‘Inner Wire Clamp Magnet Align Tool’ and the ‘Magnet Flag Pin’ to insert the magnets (4). To keep the magnetic field ‘neutral’, the magnet on either side the ‘Inner Wire Clamp’ need to have opposite polarity. Both the ‘N’ needs to be facing outwards.

5.2. PEEK Flag Assembly

Assemble the PEEK flag using ‘Flag Magnet Assembly Tool’ and the ‘Magnet Flag Pin’. Count the number of flags you have and make two equal groups. One group will be ‘North’, while the other will be ‘South’, referring to the orientation of the magnet inside the flag.

Prior inserting the magnet into the back of the flag, align the polarity of the magnet such that 'N' is facing out. Use a sharp marker and scratch an 'X' on the face of all the flags within this group.

On the second group align the magnet such that 'S' is facing out. Mark the face of the flag with an 'O'.

NOTE: The 'X' and 'O' mark are chosen for 'easy' marking using a sharp tool. Instead of the 'X' mark, one can make a 'N'. Also instead of the 'O' mark, one can make an 'S'.

6. Assemble Suspension Wire

The suspension wire is assembled using a Wire Jig, see Figure 19.

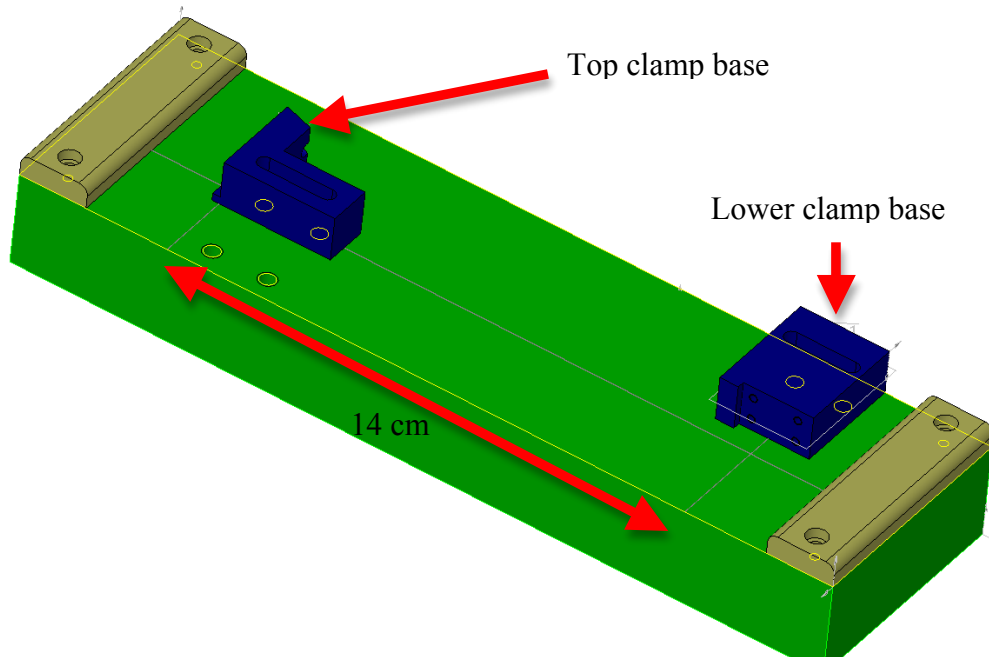

Figure 19. HTTS Wire Jig Assembly. The aluminium base is made green for clarity.

Make sure the pendulum length is 140 mm, with the actual distance between the wire clamps slightly longer. This is achieved by locating the two clamp holders, around the inscribed lines in the base tool.

The top wire clamp is bolted to the top clamp base, while the 'inner wire clamp' is bolted to the lower clamp base. There are two wire assemblies required per HTTS, there is a left and a right version (seen from the front). They are different, in that the wire is clamped off-center in the 'inner wire clamp'. This is achieved by offsetting the 'inner wire clamp' in the lower clamp base. The 'inner wire clamp' has four (4) slotted holes. When securing the 'inner wire clamp' to the lower clamp base using two (or four) #2-56 button head socket screws, the 'inner wire clamp' is pushed down, or pushed up.

When pushed **down**, the **right** suspension wire is made (seen from the front), and when pushed **up**, the **left** suspension wire is made.

This is required to help in balancing the optic.

7. Assemble Suspending Mirror

Drawing:

1. Tip-Tilt Flag Magnet Assembly Tool ([D1100862](#))
2. aLIGO HAM Tip-Tilt Inner Wire Clamp Magnet Align Tool ([D1100914](#))
3. aLIGO HAM Tip-Tilt Suspension Magnet Flag Align Tool ([D1100915](#))
4. aLIGO HAM Tip-Tilt Suspension Magnet Flag Pin ([D1100916](#))
5. Tip-Tilt Mirror – Nudge ([D1001648](#))

The 2” mirror is secured using a small round piece PTFE (‘mirror nudge’), which is in turn held in place with a #4 set screw. It is possible that the mirror nudge is too thick, and makes it hard to insert and remove the mirror. Before you install the mirror, use a scalpel to thin down the mirror nudge. Start on one side first, and work your way around until the mirror nudge slide into the opening.

When assembling the suspended mirror, do not use the real optic, use the dummy. Note that a fair amount of pressure is required to compress the mirror nudge so the mirror is securely pressed onto the two little locators at the bottom of the mirror holder.

Before (un)mounting the optic, you will need to remove the two front Eddy Current Dampers, if you not already done so.

Slide the ‘inner wire clamps’ into the cut-out on the side of the mirror holders. Insert at least one #2-56 button head socket screw. Do one side at the time. Once in place insert the remaining #2-56 button head socket screws.

8. Pre-Balancing

Check the balance of the unit using a dummy optic and a laser pointer. A fine adjustment is not necessary, all you need to do is to confirm that you can make the mirror top point down to one adjustment extreme, and up to the other end of the adjustment extreme. This adjustment is made using the ‘balance adjuster’, the 1” long #8/32 socket set screw at the bottom of the mirror holder (#11 in figure 18).

Place the bottom of the HTTS on a table that is level. Back off the blade stops and all ECD screws so the mirror holder is suspended without touching anything.

Mount the laser pointer at 4 inches above the table surface and level it using the ruler. Place the laser pointer about a meter away from the front surface of the mirror and find the reflection.

If the mirror is tilting down (i.e. the reflection is too low), screw the balance adjuster in. If the mirror is pointing up, pull the adjuster out.

Confirm that you can point the beam higher than and lower than horizontal. After that, balance the mirror to the neutral position as well as you can.

If you cannot balance by merely using the balance screw, do not try to reposition the wire in the wire clamp, instead you need to change the position of the wire clamp on the side of the mirror holder using the slop of the screw holes. If you still cannot balance, you might want to go back to « 6. Assemble Suspension Wire » section.

9. Finalising the Assembly

Drawing:

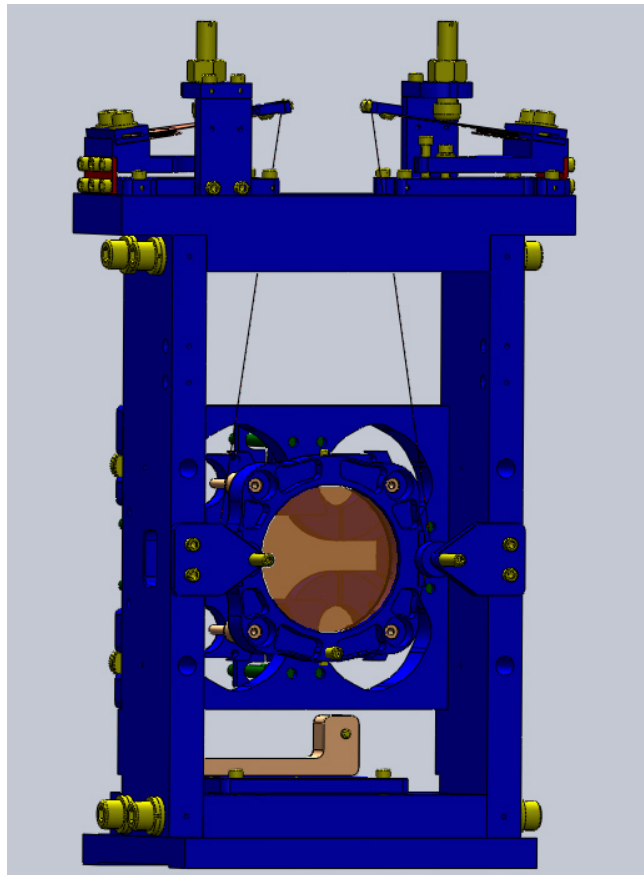

Figure 20. Fully assembled HTTS, note the relocation of the 25-pin D-Sub connector bracket on the base.

Now that the mirror is roughly balanced, you need to check the position of the mirror relative to the surrounding structure.

Look at the BOSEM holes and see if the tip of the BOSEM flags are centered. If not, change blade angles to move the mirror up or down or rotate the mirror around the axis vertical to the mirror. To move the mirror side ways, or rotate around the vertical, loosen the four (4) screws which bolt the blade assemblies to the top-plate. Move the blade assemblies (using the slop in the screw holes) to move the mirror side ways or rotate the mirror around the vertical axis.

After everything looks good, remove the dummy optic from the mirror holder, set the blade stops so they barely touch the blades, mount the front ECD plates with ECDs, use the front and the back ECDs to fix the mirror holder in position, wrap the entire structure in aluminum foil, then in a double ameristat bags, and then in storage.

10. Appendix A. Torque Specifications (Generic SS)

Material: Stainless Steel
Screw Type: Socket Head Cap Screw (SHCS)
Mfgr./Vendor: McMaster-Carr, U-C Components and HoloKrome

<i>Thread</i>	<i>Torque (in-lbs)</i>	<i>Torque (ft-lbs)</i>
#2-56	2.5	-
#4-40	5.2	-
#8-32	19.8	0.8
¼"-20	75.2	6.3

Material: Stainless Steel
Screw Type: Socket Button Head Cap Screw (SBCS)
Mfgr./Vendor: McMaster-Carr, U-C Components and HoloKrome

<i>Thread</i>	<i>Torque (in-lbs)</i>	<i>Torque (ft-lbs)</i>
#2-56	2.5	-
¼"-20	75.2	6.3

Material: Titanium
Screw Type: Socket Set Screw
Mfgr./Vendor:

<i>Thread</i>	<i>Torque (in-lbs)</i>	<i>Torque (ft-lbs)</i>
#8-32	2	-