

NOTES CONTINUED:
 5. APPROXIMATE WEIGHT = 17 LB.
 6. ASSEMBLE IN ACCORDANCE WITH SPECIFICATION E1100484

REV.	DATE	DCN #	DRAWING TREE #
v1	30 MAY 2011	E1100478-x0	E1100479
v2	8 JUL 2011	E1100478-v1	E1100479
v3	23 SEP 2011	E1100478-v4	-
v4	12 MAR 2012	E1100478-v4	-

D1100999 aLIGO, high quality, non-wedged, 6in Viewport Assy, PART PDM REV: X-015, DRAWING PDM REV: X-013

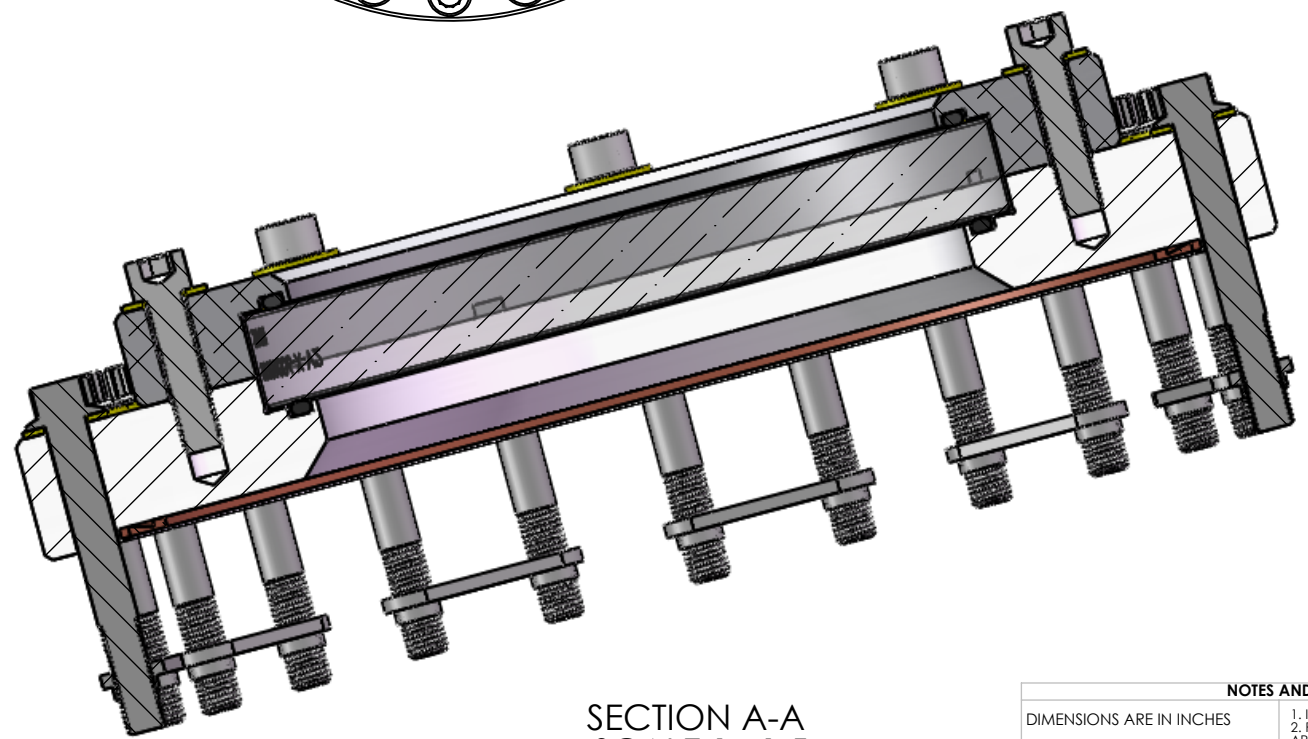
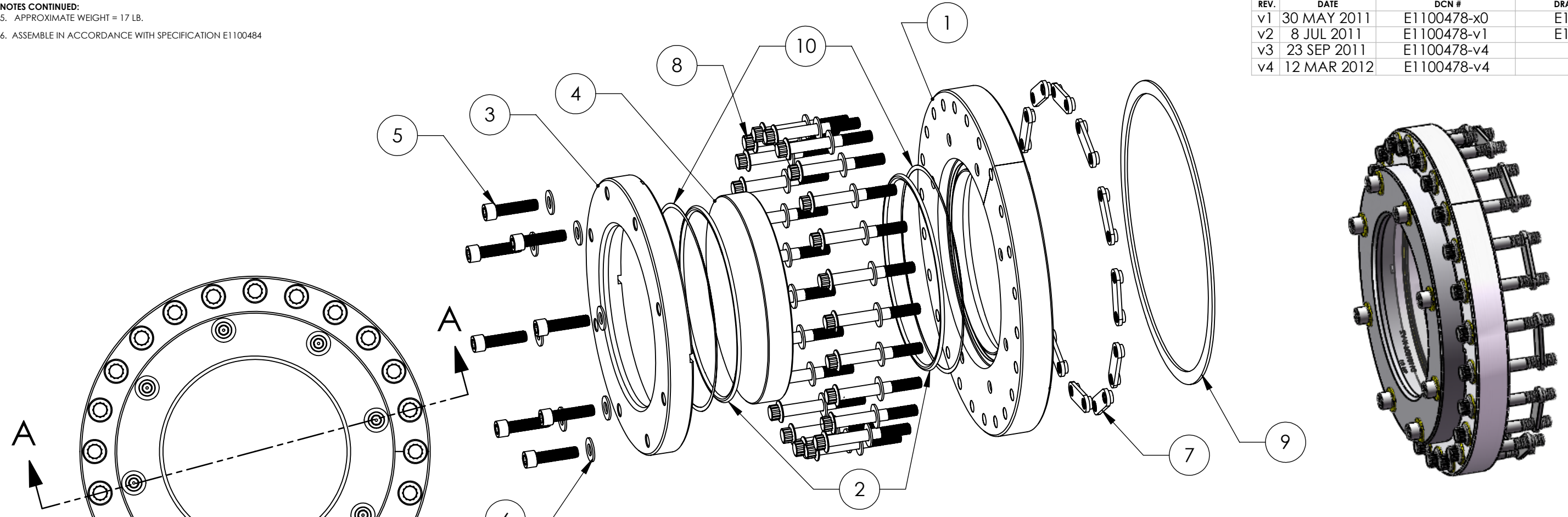

SECTION A-A
SCALE 1 : 1.5

ITEM NO.	PART NUMBER	QTY.
1	D1101001 aLIGO, high quality, 6in Viewport Flange	1
2	Parker O-Ring #2-253, Viton(R) Fluorocarbon (KFM), 75 Shore A or equivalent. O-Rings must match-must be from the same lot/batch.	2
3	D1101002 aLIGO, high quality, 6in Viewport Clamp	1
4	D1101006-1 aLIGO, high quality, non-wedged, 6in Viewport, Optic AR1064/532	1
5	5/16-24 UNF x 1.25", Silver Plated, UC Components #C-3120-NA or equivalent	8
6	5/16" FLAT WASHERS, NAS 1149-C0563R (OR EQUIV.)	8
7	Nut Plate, 10" Conflat, Nor-Cal NP-800 or equivalent	12
8	5/16-24 UNF x 2.5", Silver Plated, 12 PT Flange Bolt, and Washers MDC Kit #190067 (qty 25) or equivalent, discard nut.	24
9	Copper Gasket, 10" Conflat, MDC #191019 or equivalent	1
10	D1003207 aLIGO, high quality, 6in Viewport, Viewport Spacer	2

NOTES AND TOLERANCES: (UNLESS OTHERWISE SPECIFIED)
 DIMENSIONS ARE IN INCHES
 TOLERANCES:
 .XX ± .03
 .XXX ± .010
 ANGULAR ± 1.0°
 1. INTERPRET DRAWING PER ASME Y14.5-1994.
 2. REMOVE ALL SHARP EDGES, .005-.015, FOR MACHINED PARTS. ROUND ALL EDGES APPROXIMATELY R.02 FOR SHEET METAL PARTS.
 3. DO NOT SCALE FROM DRAWING.
 4. ALL MACHINING FLUIDS MUST BE FULLY SYNTHETIC, FULLY WATER SOLUBLE AND FREE OF SULFUR, SILICONE, AND CHLORINE.
 MATERIAL N/A FINISH N/A μinch

CALIFORNIA INSTITUTE OF TECHNOLOGY MASSACHUSETTS INSTITUTE OF TECHNOLOGY	PART NAME		High Quality, Non-Wedged, 6in Viewport Assy_AR1064/532	
	SYSTEM	AOS	SUB-SYSTEM	SLC
DESIGNER	Dennis Coyne	30 May 2011	SIZE	DWG. NO.
DRAFTER	Dennis Coyne	30 May 2011	B	D1100999
CHECKER	Mike Smith	31 May 2011	SCALE	1:4
APPROVAL	See DCN	06 JAN 2012	PROJECTION	
				SHEET 1 OF 1