

REV.	DATE	DCN #	DRAWING TREE #
v1	5 May 2011	E1100408	E1100409

CONFIGURATIONS DIFFER AS A FUNCTION OF SHAFT HOLES USED, MIRROR POSITION CAN BE TRANSLATED BY THE COMBINATION OF HOLES USED.

CONFIGURATION 1

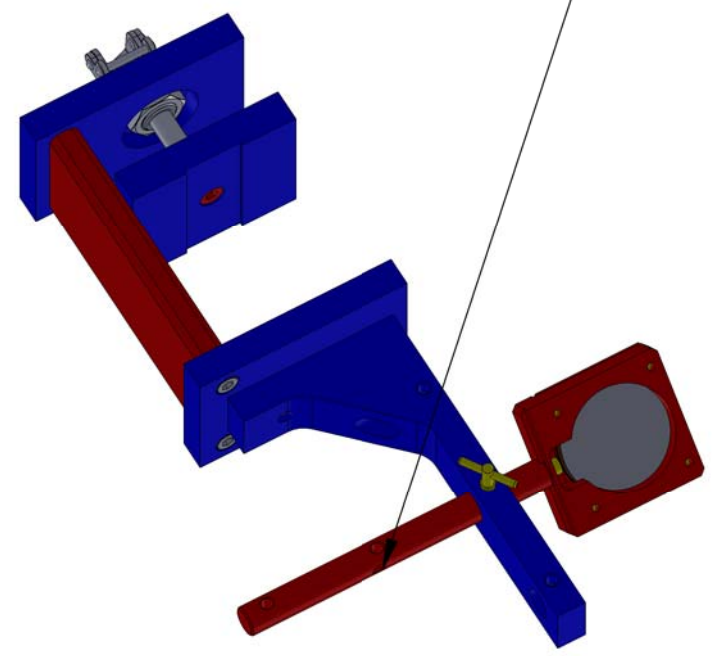

QTY. SAME BOTH CONFIGURATIONS

NOTE 6

5

CONFIGURATION 2

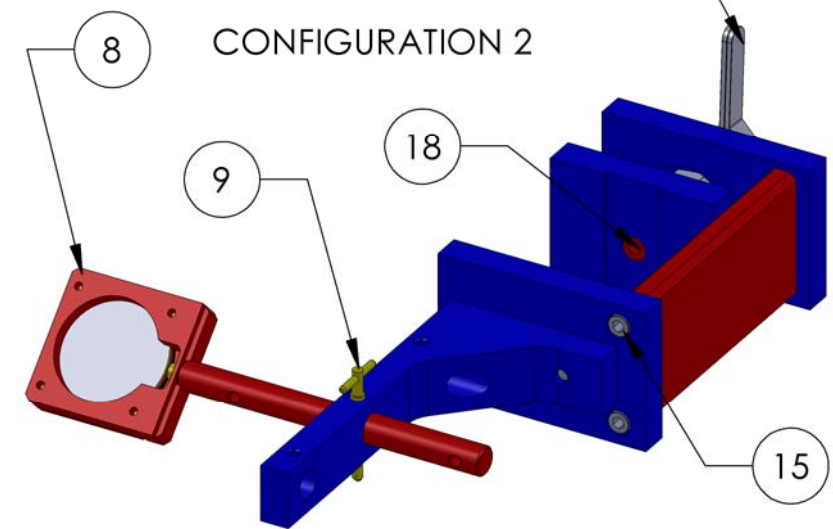

18	McMASTER_97345A578	SHOULDER SCREW, 1/4-20 THD 5/16 DIA SHOULDER X 1/2 LG	316 SSTL	1	1
17	McMASTER_92217A475	WASHER .34 ID X .75 OD X .04-.06 THK.	316 SSTL	1	1
16	McMASTER_9713k65	BELLEVILLE SPRING WASHER, .317 ID X .625 OD X .022 THK	302 SSTL	6	6
15	HOLOKROME_78056	SHCS, 1/4"-20x.625"	18-8 SS	6	6
14	MSC_05667043	SCREW SHCS, 8-32 X 3/8 LG	18-8 SSTL	5	5
13	McMASTER_92217A475	WASHER .28 ID X .73 OD X .05-.08 THK.	18-8 SSTL	1	1
12	D1100804	BOSEM 45 DEG MIRROR TOP	304 SSTL	1	1
11	McMASTER_1201T751	O-RING, AS568A-032 .070" THK X 1.87" ID	VITON	1	1
10	EDMUND OPTICS_NT64-440	2" DIA MIRROR	BK7 GLASS	1	1
9	McMASTER_98405A012	QUICK RELEASE PIN	18-8 SSTL	1	1
8	D1100798	BOSEM 45 JIG MIRROR MOUNT	304 SSTL	1	1
7	D1100797	BOSEM 45 DEG MIRROR JIG SHAFT	304 SSTL	1	1
6	D1100767	BOSEM 45 DEG. MIRROR JIG LEG	6061-T6 Al	1	1
5	CarrLane-150-TPC-S	TOGGLE CLAMP	STAINLESS STEEL	1	1
4	D1100768	BOSEM 45 DEG MIRROR JIG PUSHER	6061-T6 Al	1	1
3	D1100774	BOSEM 45 DEG MIRROR JIG PUSHER MOUNT	6061-T6 Al	1	1
2	D1100765	BOSEM 45 DEG MIRROR JIG SPACER	304 SSTL	1	1
1	D1100766	BOSEM 45 DEG MIRROR JIG END BLOCK	6061-T6 Al	1	1
ITEM NO.	PART NUMBER	DESCRIPTION	MATERIAL	QTY C-1	QTY. C-2

NOTES CONTINUED:
 4. VENDOR REFERENCES ARE PROVIDED AS EXAMPLES OF PARTS MEETING ALL REQUIRED SPECIFICATIONS. EQUIVALENTS ARE ALWAYS ACCEPTABLE UNLESS OTHERWISE SPECIFIED.
 5. REFER TO LIGO E0900357 FOR ASSEMBLY AND LOADING PROCEDURE.
 6. THE VINYL HANDEL ON ITEM 5 TOGGLE CLAMP MUST BEREMOVED AND CLEANED PRIOR TO USE.

NOTES AND TOLERANCES: (UNLESS OTHERWISE SPECIFIED)			PARTS LIST		PART NAME	
DIMENSIONS ARE IN INCHES TOLERANCES: .XX ± N/A .XXX ± N/A ANGULAR ± N/A *			1. INTERPRET DRAWING PER ASME Y14.5-1994. 2. REMOVE ALL SHARP EDGES, .03 x 45°. 3. DO NOT SCALE FROM DRAWING.		BOSEM 45 DEG MIRROR JIG ASSEMBLY	
MATERIAL N/A FINISH N/A μinch			SUS TOOLING		DESIGNER M.HILLARD 21 Apr. 2011 DRAFTER M.HILLARD 5 May 2011 CHECKER J.LEWIS 5 May 2011 APPROVAL C.TORRIE 5 May 2011	
LIGO CALIFORNIA INSTITUTE OF TECHNOLOGY MASSACHUSETTS INSTITUTE OF TECHNOLOGY			SYSTEM ADVANCED LIGO SUB-SYSTEM SEI		DWG. NO. D1100764 REV. v1	
SCALE: 1:2 PROJECTION:			SHEET 1 OF 2		SHEET 1 OF 2	

D1100764, PART PDM REV: X-006, DRAWING PDM REV: X-002

