

D1100671_aLIGO TMS TELE-OPT TABLE BALANCE BRIDGE TIE PLATE, PART PDM REV: X-018, DRAWING PDM REV: X-003

- NOTES CONTINUED:**
- 5. SCRIBE, ENGRAVE (A VIBRATORY TOOL MAY BE USED), LASER MARK OR MECHANICALLY STAMP (NO INKS OR DYES) DRAWING PART NUMBER, REVISION (AND VARIANT OR "TYPE" IF APPLICABLE) ON NOTED SURFACE OF PART FOLLOWED ON THE NEXT LINE WITH A THREE DIGIT SERIAL NUMBER. SERIAL NUMBERS START AT 001 FOR THE FIRST ARTICLE AND PROCEED CONSECUTIVELY. USE MINIMUM 0.12" HIGH CHARACTERS, UNLESS THE SIZE OF THE PART DICTATES SMALLER CHARACTERS. EXAMPLE: DXXXXXX-VY, TYPE-XX, S/N XXX
 - 6. APPROXIMATE WEIGHT = 1.87 LBS.
 - 7. ALL PARTS SHALL BE MANUFACTURED IN ACCORDANCE WITH LIGO SPECIFICATION E0900364.
 - 8. ALL MATERIAL IS TO BE VIRGIN MATERIAL (i.e. NO WELD REPAIRS, PLUGS OR RECYCLED MATERIAL). NO REPAIRS SHALL BE MADE UNLESS APPROVED IN ADVANCE, AND IN WRITING, BY LIGO LABORATORY. REFER TO LIGO-E0900364.
 - 9. SURFACE FINISH TO BE AS-PROCESSED FROM MILL/SUPPLIER, FREE FROM SCRATCHES OR GOUGES.

REV.	DATE	DCN #	DRAWING TREE #
v1	14 JUN 2011	E1100355-v1	-
-	-	-	-
-	-	-	-

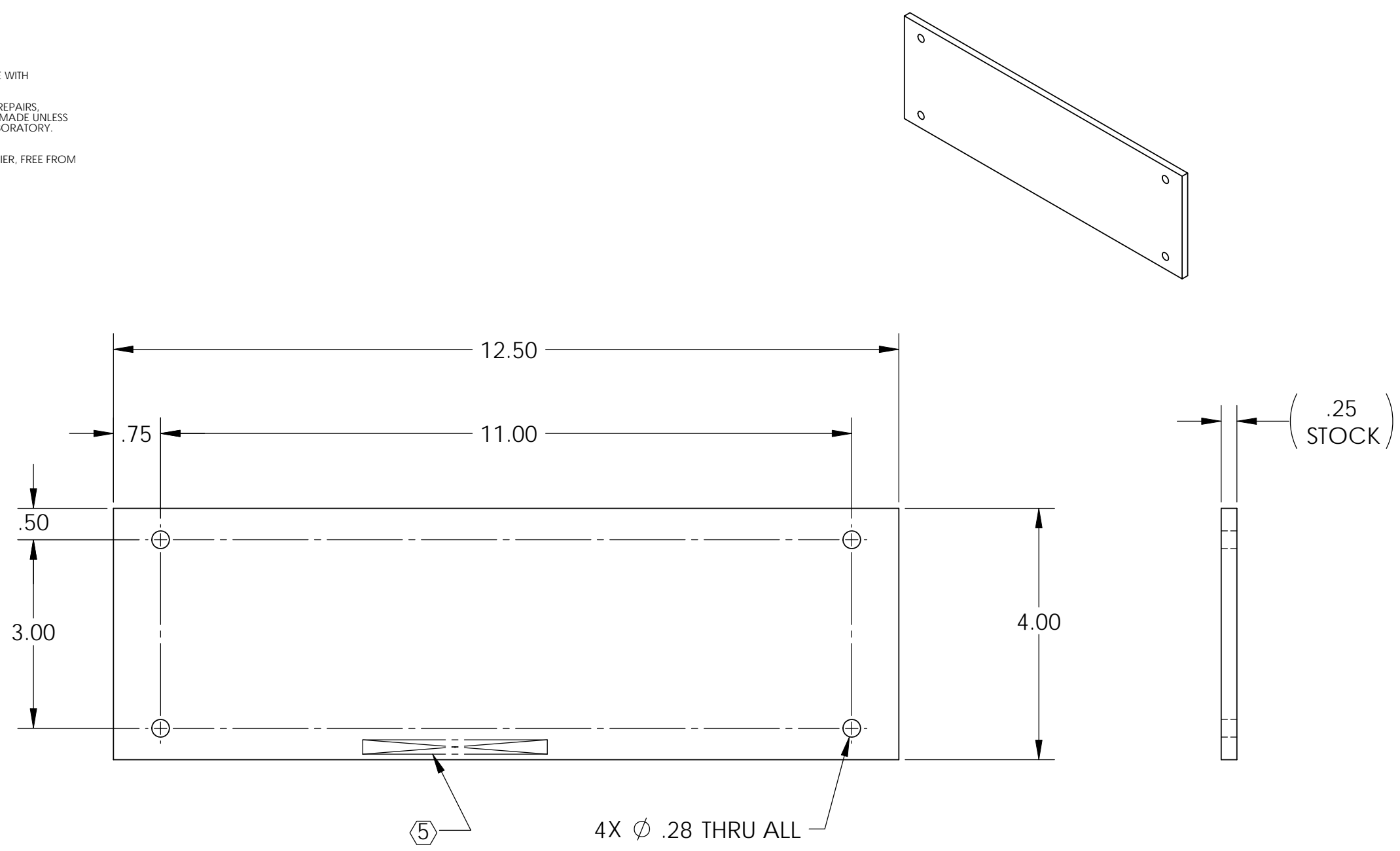

NOTES AND TOLERANCES: (UNLESS OTHERWISE SPECIFIED)				LIGO CALIFORNIA INSTITUTE OF TECHNOLOGY MASSACHUSETTS INSTITUTE OF TECHNOLOGY		PART NAME	
DIMENSIONS ARE IN INCHES TOLERANCES: .XX ± .02 .XXX ± .005 ANGULAR ± 1.0°				1. INTERPRET DRAWING PER ASME Y14.5-1994. 2. REMOVE ALL SHARP EDGES, .005-.015, FOR MACHINED PARTS. ROUND ALL EDGES APPROXIMATELY R.02 FOR SHEET METAL PARTS. 3. DO NOT SCALE FROM DRAWING. 4. ALL MACHINING FLUIDS MUST BE FULLY SYNTHETIC, FULLY WATER SOLUBLE AND FREE OF SULFUR, SILICONE, AND CHLORINE.		aLIGO TMS TELE-OPT TABLE BALANCE BRIDGE TIE PLATE	
MATERIAL		FINISH		SYSTEM	SUB-SYSTEM	DESIGNER	DATE
6061-T6 Al		μinch		ADVANCED LIGO	AOS	J. TERRAZAS	13 APR 2011
NEXT ASSY				SIZE	DWG. NO.	CHECKER	REV.
D1100649				B	D1100671	J. TERRAZAS	v1
				APPROVAL	SCALE: 1:2	PROJECTION:	SHEET 1 OF 1