

**LIGO VACUUM EQUIPMENT
FINAL DESIGN REPORT
VOLUME II
DESIGN**

LIGO-C960963-01-V

CONTRACT NO:	PC 175730
PSI DOCUMENT NO:	V049-1-097
PROGRAM I.D.	LIGO VACUUM EQUIPMENT
CDRL NO:	03
APPROVAL STATUS:	A

**Process Systems International, Inc.
20 Walkup Drive
Westborough, MA 01581**

CALIFORNIA INSTITUTE OF TECHNOLOGY
MASSACHUSETTS INSTITUTE OF TECHNOLOGY

LIGO PROJECT

FINAL DESIGN REPORT

VOLUME II

DESIGN

CONTRACT NO: PC 175730
PSI DOCUMENT NO: V049-1-097 Rev. 1
PROGRAM I.D. LIGO VACUUM EQUIPMENT
ISSUE DATE: NOVEMBER 16, 1996
CDRL NO: 03
APPROVAL STATUS: A

SUBMITTED TO:

California Institute Of Technology
391 South Holliston Avenue
Pasadena, CA 91125

SUBMITTED BY:

Process Systems International, Inc.
20 Walkup Drive
Westborough, MA 01581

Technical Director: D. A. McWilliams
David McWilliams

Project Manager: Richard Bagley
Richard Bagley, P.E.

**LIGO VACUUM EQUIPMENT
FINAL DESIGN REPORT
CDRL 03
VOLUME TABLE OF CONTENTS**

VOLUME	TITLE
Volume I	Project Management Plan
Volume II	Design
Volume II Attachment 1	Calculations
Volume II Attachment 2	Calculations
Volume II Attachment 3	Calculations
Volume II Attachment 4	Calculations
Volume II Attachment 5	Specifications/Misc.
Volume III	Fabrication
Volume IV	Installation/Commissioning
Volume V	
Book 1	Mechanical Drawings
Book 2	Electrical Drawings

**LIGO PHASE B
FINAL DESIGN
CDRL 03**

TABLE OF CONTENTS

Volume II

Vacuum Equipment Design

SECTION

1.0 SYSTEM DESIGN SUMMARY

- 1.1 Key Design Decisions
- 1.2 FDR Action List
- 1.3 Design Requirements
- 1.4 Design Verification
- 1.5 Project Q.A. Plan
- 1.6 Safety and Reliability
- 1.7 Deleted
- 1.8 Codes and Standards

2.0 VACUUM PERFORMANCE

- 2.1 Leak Rate
- 2.2 Outgassing and Ultimate Pressures
- 2.3 Pumpdown
- 2.4 Bakeout Capability

3.0 DESIGN

3.1 Station Design

- 3.1.1 Equipment Arrangement
 - 3.1.1.1 WA Corner Station
 - 3.1.1.2 WA Mid Station
 - 3.1.1.3 WA & LA End Station
- 3.1.2 Utilities
 - 3.1.2.1 Electrical Power
 - 3.1.2.2 Cooling Water
 - 3.1.2.3 Instrument Air
- 3.1.3 Interfaces to Buildings and Utilities
 - 3.1.3.1 Electrical
 - 3.1.3.2 Mechanical
- 3.1.4 Interfaces to Process Control System
 - 3.1.4.1 WA Corner Station
 - 3.1.4.2 WA Mid Station
 - 3.1.4.3 WA End Station

| = Indicates Revision To That Section

3.2 Vacuum Enclosure

3.2.1 Design

- 3.2.1.1 Beam Splitter Chamber
- 3.2.1.2 Horizontal Access Module
- 3.2.1.3 Beam Tube Manifolds
- 3.2.1.4 Mode Cleaner Tubes
- 3.2.1.5 80 K Cryopumps
- 3.2.1.6 Common Items
 - 3.2.1.6.1 Materials
 - 3.2.1.6.2 Cleaning
 - 3.2.1.6.3 Welding
 - 3.2.1.6.4 Alignment and Dimensions
 - 3.2.1.6.5 Mechanical Loads
 - 3.2.1.6.6 Flanges and Ports
 - 3.2.1.6.7 Flange Annuli
 - 3.2.1.6.8 Access Connectors
 - 3.2.1.6.9 Fasteners
 - 3.2.1.6.10 Bellows

3.3 Pumps

- 3.3.1 Main Roughing System
- 3.3.2 Main Turbomolecular Pump System
- 3.3.3 Auxiliary Turbomolecular Pump System
- 3.3.4 Main Ion Pumps
- 3.3.5 Annulus Ion Pumps
- 3.3.6 80 K Pumps

3.4 Valves

- 3.4.1 Large Gate Valves
- 3.4.2 Small Valves

3.5 Vent and Purge System

- 3.5.1 Clean Air Supply
- 3.5.2 Portable Softwall Cleanrooms/Systems

3.6 Bakeout/Heating System

- 3.6.1 Bakeout Blankets
- 3.6.2 Bakeout Control System

3.7 Monitor and Control System

- 3.7.1 Vacuum Gauging
- 3.7.2 Other Instruments
- 3.7.3 Cabinets
- 3.7.4 Interlocks
- 3.7.5 Required Controls by Others

4.0 SHOCK, VIBRATION AND ACOUSTICS

- 4.1 Shock
- 4.2 Vibration
- 4.3 Acoustics
- 4.4 Technical Approach to Shock, Vibration and Acoustics/Risk Mitigation
- 4.5 Source Measurement and Transmission Analysis

ATTACHMENTS

Attachment 1

Calculations

Structural Design Criteria
BSC's - Structural
General - Structural
HAM - Structural

Attachment 2

Calculations

80K Cryopump - Structural
Adapters and Spools - Structural

Attachment 3

Calculations

Adapters and Spools - Structural

Attachment 4

Calculations

Vacuum and Process Calculations
Safety and Reliability Analysis

Attachment 5

Specifications/Miscellaneous

Shock, Vibrations and Acoustics
Design Goals/Requirements
Specifications



FINAL DESIGN REPORT

VOLUME II DESIGN

1.0 SYSTEM DESIGN SUMMARY

The purpose of this Final Design Report is to document and validate the PSI design of the LIGO Vacuum Equipment. The criterion for system design throughout this effort has been to assure that the LIGO Vacuum Equipment achieves the required level of vacuum performance as defined in the LIGO/PSI contract. As you read through this Final Design Report, you will note that PSI's understanding of the design philosophy presented in LIGO specification No. E940002-02-V and subsequent addenda, is accurately and efficiently reflected in the detailed design.

The following points are addressed in this report:

- Key Design Decisions
- PDR Action Item Resolution
- LIGO Requirements vs. PSI Design
- Design verification through testing and/or analysis (ISO-9001 approach)
- Project Quality Assurance Program
- Safety and Reliability

The scope of the attached drawing package is limited to the Washington site design. The Louisiana drawing package will be completed upon approval of the Washington design and the issuing of the Louisiana building drawings.

1.1 Key Design Decisions

Throughout the execution of the proposal, preliminary design, and the final design process, PSI has made a number of key decisions to manage technical risk and optimize system performance. These decisions are summarized below along with the basis for the decision.

Key Decision	Issue	Justification
1. Double Viton O-rings	Vacuum performance	<ul style="list-style-type: none">• Metal O-rings present an unacceptable risk, since potential vendors will not guarantee performance.• Metal O-rings of the size required for LIGO have not been used in UHV service.• Gasket seating loads for metal O-rings are not well understood. Very high seating loads are required resulting in very thick flanges with many bolts.• Viton O-rings with a pumped annulus can provide predictable vacuum performance. Gas loads from permeation and outgassing can be predicted with confidence.
2. Place all roughing equipment in mechanical room	Noise and vibration	<ul style="list-style-type: none">• Moves a major source of noise and vibration on a separate foundation away from the optics.
3. Investigate cleaning methods	Vacuum performance	<ul style="list-style-type: none">• Identification of suitable detergents.• Develop cleaning protocol.• Define washing equipment requirements.
4. Prototype vessel	Design verification	<ul style="list-style-type: none">• Verify flange design.• Verify manufacturing methods.• Verify stress relieving effectiveness.• Measure cryopump vibration.

5. Bench scale prototype	Early verification of design data	<ul style="list-style-type: none"> • Verify effectiveness of cleaning techniques by measuring outgassing rates from the metal. • Verify that stress relieving protocol does not adversely affect H₂ outgassing. • Verify O-ring outgassing and permeation rates. • Verify O-ring bakeout protocol. • Verify O-ring groove design. • Verify O-ring manufacturing method.
6. Noise & vibration testing program	Design data for vibration model	<ul style="list-style-type: none"> • Provide realistic source data to improve confidence level in vibration models.
7. Oversized vessel nozzles	Alignment	<ul style="list-style-type: none"> • 60" nozzles are oversized to accommodate manufacturing tolerances.
8. Alignment slots	Alignment	<ul style="list-style-type: none"> • Slots have been added to flange bolt holes between fixed sections to allow for some angular misalignment.
9. Plasma welding	Alignment	<ul style="list-style-type: none"> • Reduction in weld distortion by reduced heating of weld joint.

1.2 Action Item Resolution List

There were two sets of action items resulting from the PDR Update meeting.

- A list of 12 action items of which 9 were assigned to PSI and which are addressed in this section.
- A second list of 22 items from TDM 03 related specifically to the text of the PDR. These items have been previously addressed and have been included in the final version of the PDR Update, CDRL 01, and are therefore not discussed here.

Table 1.2 summarizes the resolution of the nine action items assigned to PSI from the PDR Update meeting.

TABLE 1.2

Action Item	Issue	Resolution
1. Foreign Materials	LIGO QA suggested that materials from foreign sources require independent lab analysis of the material properties.	This item is included in the QA Plan V049-2-029.
3. Water Outgassing Rate	The water outgassing rate at 10 minutes of 2×10^{-8} TI/sec cm^2 may be optimistic. What is the impact of 10x higher on the pumpdown?	All of the pumpdown calculations have been updated for the FDR and are included in Attachment 4. The outgassing rate at the end of the 100 hour pumpdown is considered to be more important than the 10 minute rate. The design values used after 100 hours of pumping are: <ul style="list-style-type: none">• Viton: 3×10^{-9} torr-l/s-cm^2 for 0.5 hour re-exposure to air.• Stainless: 5×10^{-11} torr-l/s-cm^2
5. Low Emissivity Liner	PSI was requested to check the calculations of the low e liner by an independent means.	The liner calculations were confirmed by an independent model. These calculations can be found in Attachment 4.
6. Electric Gate Valves	PSI was requested to consider using electric actuators on all of the large gate valves.	The definition of the size and type of gate valves was determined by LIGO and provided to PSI by TIM 9.

7. Ion Pump
Vibration

It was suggested that the analysis of potential vibration sources include the ion pumps. The unregulated power supplies used in most ion pumps might couple 60 Hz or multiples thereof into the ion pump structure.

Ion pump vibration will be measured as part of vibration source data collection included in CAA scope of work.

8. Post Weld
Stress Relief

It has been suggested that the furnace treatment can have a positive or negative impact on the vessel outgassing. (Positive if done in a clean environment, potentially negative, if hydrocarbons are baked onto the vessel surface.)

Steam cleaning prior to stress relief and control of the furnace to provide excess O₂ is included in the stress relief procedure, V049-2-046 which is included in Volume III Fabrication.

The verification of the post weld stress relief process is included in the bench scale prototype and BSC prototype testing programs.

9. CH₄ Pumping
Speed

CH₄ Pumping speed data in ion pumps was requested. Why is the CH₄ speed greater than air.

The pumping speed of CH₄ has been confirmed to be greater than the pumping speed of N₂ by Varian, the supplier of the ion pumps. The reason for the high pumping speed is the methane molecule is cracked and transformed into smaller compounds such as C, CH₃,...H. The lighter compounds always have a higher pumping speed than N₂.

10. QA Audit Points

LIGO requested definition of suggested QA audit points of PSI and PSI subcontractors.

This item is included in the following documents.

- QA Plan V049-2-029 Sections 4.3.2- Vendor Surveillance and 4.10.2-QA requirements.
- BSC Procurement Plan V049-2-080.
- HAM Procurement Plan V049-2-081.

11. All Metal Foil

Investigate all metal aluminum foil as insulation on 80 K cryopumps

As part of the engineering analysis it was determined that the heat load contribution from the ambient temperature walls is a relatively small portion of the total heat load. Additional shielding would provide only marginal benefit (app 2 %) and makes the assembly of the vessel more difficult.

1.3 Design Requirements

1. ISO-9001 Approach

The LIGO system will be designed, fabricated and installed using ISO-9001 type philosophies including design input verification, design review, independent analysis, etc.

2. Designs Goals

Each component or subsystem has been reviewed for compliance to the specification via a "Design Goals/Requirements Form". The specification requirements are listed along with a specific method meeting the requirements, and identifies the engineer responsible to complete any action items. This document is a working document that is updated and revised at each design review. The Design Goals are detailed in Volume II, Attachment 5.

3. Equipment Specifications

Equipment specifications are generated for each major component. These specifications are reviewed against the project specification for compliance using the Design Goals/ Requirements Form.

4. Design Reviews

Each major component or subsystem undergo internal design reviews, where the cognizant engineer and other members of the design team review the design for technical feasibility, specification compliance, safety, and operability.

1.4 Design Verification

1. Analyses

Design verification is provided by analysis where applicable by codes and standards or where adequate methods exist. All analyses are checked independently. Analyses necessary to support the design are included in the attachments. Analyses are organized as follows:

- Attachment 1, 2, 3 - Structural
- Attachment 4 - Vacuum and Process
 - Safety and Reliability
- Attachment 5 - Shock, Vibration, and Acoustics
 - Design Goals/Requirements Specifications

Where insufficient data exists to depend on analyses alone, additional testing has been or will be undertaken to provide the necessary supporting data. Examples in this category include:

- Outgassing from metal and elastomers
- O-ring permeation
- Gate valve shock
- Source vibration from turbopumps, ion pumps, and cryopumps
- Flange design under tensile loading

2. Bench Scale Testing

- PSI has continued the cleaning evaluation program initiated during the Preliminary Design. A washing station has been constructed that allows testing of various cleaning agents.
- A Bench Scale prototype has been constructed and is being used for qualification testing of welding techniques, cleaning methods, outgassing rates, O-ring performance and baking protocol, clean room assembly methods, and leak detection methods.
- A test setup was constructed and vibration characteristics of two phase flow simulating the flow regime entering the 80K cryopumps were measured.
- The O-ring sealing under tension loading will be verified by pressure testing a flange with the same geometry as the full scale design.

3. Prototype Testing

A prototype BSC has been constructed. This unit provided full scale verification of the fabrication methods including, welding procedures, fixturing, stress relieving, and cleaning. The BSC prototype also provided a test vehicle for 80K cryopump vibration testing.

4. First Article Fabrication Approach

The LIGO vessel designs and procedures will be validated on one unit before the entire order is released for fabrication. A HAM first article will be constructed prior to release of the production lot. As with the BSC prototype, confirmation of the fabrication methods will be verified.

1.5 Project Quality Assurance Program

The overall project quality assurance strategy is detailed in V049-2-029 "Project Q.A. Plan".

Project Quality Assurance begins with understanding the contract requirements and ends with accurately recording performance data. In between the Quality Assurance program forms the backbone of a strategic risk management plan.

Timely reviews of engineering, design, procurement, vendor performance greatly increase the probability of a successful project. PSI has adopted this philosophy in its execution of design engineering and throughout the entire project.

PSI Q.A. program includes the following:

- ISO-9001 Design Approach
- Component Design Reviews
- Station Design Reviews
- Vendor Q.A. Requirements
- Vendor Audits
- Vendor Inprocess and Final Inspection
- Vendor Performance Tests

1.6 Safety and Reliability

PSI has generated a Hazards Analysis as required by the Statement of Work and detailed in the LIGO System Safety Plan. The major types of equipment and operations were analyzed with respect to hazards that result in injury to personnel, or damage to equipment or the environment. A Failure Modes, Effects, and Criticality Analysis has also been performed.

The complete Preliminary Hazards Analysis, Document V049-2-093 and the associated Failure Modes, Effects, and Criticality Analysis, Document V049-2-094 can be found in Volume II, Attachment 4.

1.7 Status of Bench Scale Qualification Testing

(This section deleted.)

2. Bench Scale Vessel

The first set of vacuum tests have been completed on the 10" Bench Scale vessel. These tests were made on a vessel that has a mill finish, was detergent cleaned with a pressure wash, and was not stress relieved. The purpose of this testing was to establish baseline outgassing rates after a 48 hour bake at 150C.

1.8 Codes and Standards

The following standards are incorporated as applicable. Requirements as set forth in the specification have final precedence.

1. **American Society of Mechanical Engineers (ASME) Boiler and Pressure Vessel Code**
 - Materials, Section II
 - Pressure Vessels, Section VIII, Division 1 and 2.
 - Welding and Brazing Qualifications, Section IX.
2. **American Society for Testing and Materials**
 - ASTM E498-Standard Test Methods for leaks using the Mass Spectrometer Leak Detector.
3. **Handbook of Acoustical Measurements and Noise Control**
 - Chapter 43, Noise Criteria for Heating, Ventilation, and Air Conditioning Systems.
4. **International Standards Organization**
 - ISO Standard 2861-Flange Standards.
5. **American Society of Civil Engineers**
 - Minimum Design Loads for Buildings and Other Structures, ASCE 7-88
6. **Expansion Joint Manufacturer's Association (EJMA)**
 - Standards for Expansion Joint Manufacturer's Association.
7. **National Fire Protection Association (NFPA) Standards**
 - No. 70-National Electrical Code.
8. **Government Standards**
 - Federal Standard 209 for clean rooms.
9. **American Institute of Steel Construction**
 - Manual of Steel Construction, Allowable Stress Design, Ninth Edition



2.0 VACUUM PERFORMANCE

2.1 Leak Rate

Specification Section 4.1 requires leaks greater than 1×10^{-9} torr-l/s of helium to be repaired. To demonstrate leak integrity of any individual chamber or tube section, the total leak will be measured per ASTM E498, to be less than 1×10^{-9} torr-l/s of helium at PSI.

Specification Paragraph 5.1.14 requires that leaks on each chamber or tube section be repaired at the site of manufacture. Leak checking will be performed in stages prior to shipment from the factory. A preliminary leak check will be done prior to final cleaning. Since leaks can develop in apparently tight systems following a bake [Welch, 1994, LEP Group, 1990]. PSI will conduct the final shop leak test on each chamber and tube section after it has been baked at 150C.

As each vacuum enclosure is installed at the site, the O-ring annulus of each adjacent section will be pumped to operating pressure to provide a qualitative indication of O-ring joint integrity.

The objective of these procedures is to do as much work as possible prior to the final assembly so that potential leaks in each isolatable volume are minimized. This will significantly reduce costs, schedules, and risks of overruns and delays.

A baked vacuum section can have its air leak rate directly measured by a Residual Gas Analyzer (RGA). The air signature amplitudes are compared with those from a calibrated air leak. The bakeout will eliminate or greatly reduce the level of CO and other gases etc. which can interfere with this direct measurement in unbaked systems. This RGA measurement is especially helpful when testing a complex section with many chambers. Definite knowledge that a leak exists, and the size of the leak, has a remarkable effect on the efficiency of the search for leaks. PSI plans that the total leak rate of each vacuum section be initially measured with an RGA. If no leak is detected with the air signature, then the section meets the leak requirement. Otherwise a search with a helium leak detector is initiated.

The bakeout in the shop will be done using the heater blankets developed for requirement of Specification Section 4.5; and that the LIGO main turbomolecular pumps (TMP), and auxiliary TMP's be used in the shop as far as practical. Any wear on the equipment would be far outweighed by the operating experience gained in its use.

Leak testing a chamber sealed with double O-rings requires three separate measurements: the leak from atmosphere to annulus, that from within the chamber to annulus, and that from atmosphere directly into the chamber. Permeation of helium through the Viton seals will occur in a few minutes, so all three measurements must be completed quickly.

Detailed leak test plans are included as attachments to Volume II (Fabrication) and Volume IV (Installation) and are integrated with the plans for cleaning, baking, and outgassing measurements.

2.2 Outgassing Rates And Ultimate Pressures

2.2.1 Water & Surface Desorption

The vacuum envelope will be baked at 150C to drive off surface contaminants and to potentially reduce the concentration of hydrogen in the steel.

Since the surfaces are exposed to air after the bake-out process, the surface will reabsorb water. The outgassing rates obtained when the volume is re-evacuated will vary depending on the time of exposure and the dewpoint of the air.

For design purposes the outgassing rates for water after 100 hours of pumping are:

Viton: 3×10^{-9} torr-l/s-cm² for 0.5 hour re-exposure to ambient air

Stainless: 5×10^{-11} torr-l/s-cm²

The basis of selection of the outgassing rates are discussed in detail in the "Pumpdown and Ultimate Pressure Analysis" V049-1-078 which is included in Attachment 4.

2.2.2 Hydrogen Outgassing

Since the vessel wall is baked at low temperature (150C), hydrogen outgassing rates will remain essentially as manufactured. Rates as high as 5×10^{-10} torr-l/s-cm² have been reported, and as low as and lower than, 2×10^{-12} torr-L/s-cm² (VIRGO - Final Design). Since these rates are dictated by the diffusion and/or recombination of atomic hydrogen from the bulk of the metal vessel wall which is at room temperature, the hydrogen outgassing rates will be almost unchanged over the 100 hours of pumpdown and will change less than one decade over many years (see Santeler). There are several independent sources of outgassing data that suggest that ordinary 304L stainless will have outgassing rates of less than 1×10^{-11} torr-l/s-cm². Santeler reports a 200 hour bakeout time at 150C to obtain an outgassing rate of 2×10^{-11} torr-l/s-cm² and at 250C to obtain an outgassing rate of 2×10^{-12} torr-l/s-cm² for hydrogen. VAT valve reports achieving outgassing rates of 2×10^{-13} mbar - l/s-cm² after baking for 24 hours at 150C. The VIRGO Final Design reports hydrogen outgassing rates of $2-3 \times 10^{-12}$ mbar-l/s-cm² after baking at 150C for one week.

For design purposes a H₂ outgassing rate of 1×10^{-11} torr-l/s-cm² was used.

For the design outgassing rate of 1×10^{-11} torr-L/s-cm², a surface area of 814 m² in the corner station and 20,000 l/s of ion pump speed, the achievable partial pressure of hydrogen will be about 4×10^{-9} torr.

There will be three near term opportunities to verify the water and H₂ outgassing rates; the bench scale prototype, the BSC prototype, and the HAM first article. The HAM first article will provide the best data since it will be fabricated from the same material as the early production chambers.

Data from the bench scale and BSC prototypes has indicated that the H₂ outgassing on these two samples has ranged from the mid 10^{-12} to the low 10^{-11} torr l/cm². Detailed results are found in the prototype vessel data review package V049-1-119.

2.2.3 Leakage

Corner Station

Assuming that the leakage and diffusion from a single chamber with its adjacent tube or chamber interconnecting flange joint is 1×10^{-9} torr-l/s each and that there are 100 joints per isolatable volume, then the total leakage will be 1×10^{-7} torr-l/s. The required pumping speed to hold 1×10^{-9} torr will be about 100 l/s, which corresponds to about 1% of the ion pumping capacity in the section. This value is conservative since the leakage should be better than 1×10^{-9} torr-l/s per joint.

End And Mid Stations

Assuming that the leakage and diffusion from a single chamber with its interconnecting flange joint to an adjacent tube or chamber is 1×10^{-9} torr-l/s each and that there are 25 joints, the total leakage will be 0.25×10^{-7} torr-l/s. The required pumping speed to hold 1×10^{-9} torr will be about 25 l/s, which also corresponds to about 1% of the ion pumping capacity in each station.

2.2.4 Ultimate Pressures

To achieve a partial pressure of 5×10^{-9} torr for hydrogen, the outgassing rate for hydrogen must be less than 1×10^{-11} torr-l/s-cm² with the available ion pump capacity. Since the outgassing rate for hydrogen will not decay very quickly the achievable ultimate partial pressure can be predicted by measuring the hydrogen outgassing rate after the bakeout process.

Depending on initial conditions for water content on the vessel-wall surface, it may not be possible to meet the partial pressure of 5×10^{-9} torr for water after 100 hours of pump down. However, if the partial pressure of water is only several times larger than the required partial pressure, then the desired partial pressure may be reached in a reasonable amount of time because of the quick decay of the outgassing rate for water. If the partial pressure is an order of magnitude higher, a low temperature bake out may need to be repeated.

It is difficult to predict the exact partial pressure of species other than water and hydrogen after 100 hours of pumpdown. Various investigators have measured the partial pressures of the other species after a bake out or after a pumpdown (see Dylla et al. and Moraw and Dobrozemsky). Surface outgassing rates of other species were estimated from Dylla's pumpdown measurements for partial pressures of other species after 100 minutes of pumping. A 1/t decay behavior was used for the surface outgassing rates of the other species in the pumpdown calculations.

Maximum partial pressure goals for each isolatable volume from Specification section 4.3:

Gas Species	Partial Pressure (Torr)	Comments
H ₂ O	5×10^{-9}	Varies depending on air purge conditions and bakeout
H ₂	5×10^{-9}	Depends on H ₂ content of stainless steel as manufactured
N ₂	5×10^{-10}	Vary depending on cleaning and bakeout
CO	5×10^{-10}	Vary depending on cleaning and bakeout
CO ₂	2×10^{-10}	Vary depending on cleaning and bakeout
CH ₄	2×10^{-10}	Vary depending on cleaning and bakeout
Others	5×10^{-10}	Vary depending on cleaning and bakeout

Partial Pressure Measurement

Partial pressure of the various species will be measured at the Ion pumps. With the outgassing rate dominated by water a pressure gradient for water will establish itself along the beam manifold since the cryopump is located at the far end. The partial pressure of water will vary by approximately one order of magnitude throughout the isolatable section. Partial pressure for water could be measured at two locations, one near the cryopump and another at the other end of the isolatable section. Pumpdown curves are based on the partial pressure of water near the cryopump.

Cryopumping Of Carbon Dioxide

The vapor pressure of CO_2 at 80K is about 10^{-7} torr. CO_2 will be cryopumped onto the 80K pump surface during pumpdown if a lot of CO_2 is present and will re-evaporate when the pressure drops below 10^{-7} torr, thus becoming an outgassing source in the UHV range. To minimize this effect the startup of the cryopump is delayed until the pressure is less than 1×10^{-5} torr.

2.3 Pumpdown

2.3.1 Pumpdown From 760 Torr to 0.1 Torr

To obtain a total roughing time of less than four hours for crossover to Turbo molecular pumping, the capacity of the roughing pump must average about 100 l/s. The main roughing pump package which is comprised of a roots blower with hydrokinetic drive, backed by a multistage dry pump, provides a pumpdown from atmosphere to 10^{-2} torr of approximately 2 hours for the largest isolatable volume in the corner station. For the mid and end stations that do not have separate roughing pumps, the pumpdown will be on the order of 12 to 16 hours.

2.3.2 Pumpdown From 0.1 Torr to 10^{-6} Torr

For a clean, dry system, the 1000 l/s net pumping speed at the chamber provided by a single TMP, is adequate for pumpdown of the isolatable section in 24 hours. If moisture is present in the chamber because of improper cleaning, bake out, or purging with less dry air; then either a second TMP connected at the roughing port or, operation of the 80K cryopump may be necessary in order to lower the pressure below 10^{-5} torr.

2.3.3 Pumpdown From 10^{-6} Torr to 10^{-9} Torr

Using the 80K cryopump and Ion pumps, reaching the desired ultimate partial pressures within 100 hours of pumping will be dictated by the outgassing rates and is dependent on proper cleaning and bakeout of the surfaces. To achieve the required partial pressures the outgassing rate for water, after 100 hours, needs to be about 5×10^{-11} torr-l/s-cm². The outgassing rate for hydrogen needs to be about 1×10^{-11} torr-l/s-cm², and the total outgassing rate for the other gasses needs to be about 1×10^{-12} torr-l/s-cm².

2.3.4 Pumpdown Curves

Thirty two (32) hour and 100 hour pumpdown curves of the corner, mid, and end stations are shown in V049-1-078 which can be found in Attachment 4.

2.4 Bakeout Capability

Degassing of the vacuum chamber walls requires a bake-out temperature of $150\text{C} \pm 20\text{C}$. Requirements and design criteria for the bakeout blanket system are dictated by bakeout temperature, warm-up time, maximum allowable surface temperature, practical blanket thickness and available space for installation, insulation type, cost effective design, and end effects such as gate valve's gate and vacuum envelope support legs. Additionally, higher power density heating jackets are required for baking the pressure gauges at 250C .

2.4.1 Blanket Design

2.4.1.1 Insulation thickness

To be able to reach a temperature of 150C asymptotically a certain insulation thickness/value is required for a given power input. Selection of the insulation thickness involves tradeoffs between power density, heat-up time, cooldown time, maximum allowable surface temperature and available space for installation. To maintain a reasonable cost of the blanket system and manageability of the blankets (a thick blanket makes it difficult to install onto the complex curvature of the vacuum envelope), 2 inch fiberglass insulation has been specified.

2.4.1.2 Warm-up Time

Because the warm-up is controlled to maintain temperature uniformity over the bakeout system, warm-up of the vacuum envelope will be dictated by the thickest section. At a power density of 350 W/m^2 it takes less than 48 hours to heat the thickest flange (1.5 inch). The specification requires a maximum ramp of $1.8\text{C}/\text{hour}$ and requires it to be controllable. Power density is limited to provide fail safe protection.

2.4.1.3 Cooldown Time

With a 2 inch fiberglass insulation the cooldown is estimated to take over 48 hours to approach room temperature.

2.4.1.4 Power Density

A 2 inch fiberglass insulation with a design margin of 2 for the insulating value, and a surface emissivity of 0.9 requires a power density is 350 W/m^2 to hold a temperature at 170C . The system is currently specified to have an average power density of no more than 450 W/m^2 .

2.4.2 Special Blankets

To ensure that all surfaces can be heated to at $150\text{C} \pm 20\text{C}$, certain sections need to have blankets with higher power density to maintain the required temperature on the vacuum surface.

Due to end effects on the gate spool sections, in the adjoining isolatable section next to gate valves, require a higher power density blanket in order to allow the gate being baked to reach the required temperature.

Vessel support legs which are made from carbon steel (higher thermal conductivity than stainless steel) requires a blanket system to allow the vacuum surface to reach temperature.

Pressure gauge pair bakeout at 250C requires a higher power density jacket.

2.4.3 Power Requirements

The power requirement will be the highest for the most massive isolatable section used in the bake-out. However, if sufficient amount of time is allowed for warm-up to a steady state temperature of 150C , then the minimum power requirements will be dictated by the section with the largest surface area.

The corner station in WA or LA has an isolatable section with an approximate area of 400m^2 , and at a power density of 450 W/m^2 requires a power of 180 kW .

The end station which has an approximate area of 119 m^2 requires a power of approximately 53 kW .

The mid station which has an approximate area of 162 m^2 requires a power of approximately 72 kW .

Further information on the blanket design and control is given in section 3.6 and Document V049-1-065.





3.0 DESIGN

3.1 Station Design

3.1.1 Equipment Arrangement

The basic equipment arrangement and dimensional requirements have been determined by LIGO in the Vacuum Equipment Specification LIGO-E940002-02-V, Rev. 2 and various LIGO TDM's and LIGO Preliminary ICD's to the beam tube contractor and civil contractor.

The drawings listed below at the various section headings are the PSI drawings for each station that depict the locations of the PSI Vacuum Equipment, vacuum/purge air and utility piping at the Corner, Mid and End Stations.

In general, PSI has been responsible for the location and arrangement of the following items at all the stations:

1. PSI's electrical instrumentation and control work, as shown on the drawings, provides LIGO with a complete installation, enabling proper operation of vacuum equipment. All devices and raceways are shown installed in such a way so as to avoid stay clear areas and to avoid interferences with vacuum equipment and piping systems while providing some flexibility due to possible field corrections.
2. The layout of the vacuum pump piping, the purge air/air shower piping and the utility air and cooling water headers. The piping has been routed under the beam tube manifolds and is supported 6 in. above the floor surface on pipe supports which are anchored to the floor.
3. The design and layout of the 80K cryopumps, the LN₂/GN₂ piping and the LN₂ storage tanks and associated equipment. The LN₂/GN₂ piping is supported on tee posts approximately eight feet above the floor. Note the 80K pump shell rupture disc vent line, the GN₂ relief valve discharge and the Dewar pressure regulator vent are all piped to a safe discharge zone outdoors and within a fenced off area around the LN₂ systems. The suggested fence is to be provided by LIGO.
4. The port locations for the main turbo and roughing pump carts.
5. The port locations of the main ion pumps.
6. The layout of the equipment and piping in the mechanical/vacuum support equipment rooms.
7. PSI has included circumferentially slotted holes for flange bolts on certain spools. This feature will allow easier alignment of the spools. An example of this is shown on drawing V049-4-060.

8. PSI has increased the ID's of the following items to assure LIGO minimum apertures to allow for manufacturing tolerances.

BSC's to 104.5 in. ID, from 104 in. ID

HAM's to 84.25 in. ID, from 84 in. ID

Manifolds to 72.25 ID, from 72 in. ID

Manifolds to 60.5 in ID, from 60 in. ID

Manifolds to 48.25 in. ID, from 48 in. ID

Manifolds to 44.625 in. ID, from 44 in. ID

Manifolds to 30.5 in. ID, from 30 in. ID

3.1.1.1 Washington Corner Station

Reference PSI Drawings V049-5-001 (2 Sheets), V049-5-012, V049-5-013 and V049-5-014.

The equipment has been arranged per Figure 4 of Specification LIGO-E940002-02-V Revision 2. The Final Design Review drawings reflect the following updates to the original scope drawings.

1. The HAM support saddles are anchored directly to the concrete floor.
2. The elevation of the floor surface was lowered 3 in. (measured at the vertex). This gives a dimension of 73 in. (1854 mm) between the floor surface to the beam axis centerline.
3. The 72 in. beam tube manifolds are now arranged similar to the Louisiana long tube sections to save costs on flanged sections. (Reference change order #11).
4. The HAM 60" end covers now have a symmetrical pattern vs. Figure 9 details. The HAM 84" doors have the ports spread at greater horizontal intervals to avoid nozzle reinforcement problems. (Approved per TIM 21).
5. Beam tube manifold changes in diameter are made with flat plate transitions instead of cone shaped sections. (Approved per TIM 26).
6. The orientation of LIGO vibration isolation supports for the detector equipment at BSC1 and BSC3 have been turned 90⁰ to allow easier removal of adjacent beam tube manifold sections.
7. The main ion pumps are mounted on top of the 30 in. mode cleaner tubes and the 48 in. diagonal beam tube manifolds. This was done to free up space around the BSC's which are very congested, and avoid mounting them on top of the HAM's above the optics.
8. The 30 in. x 60 in. adapter cone sections on the ends of the mode cleaner tubes have been deleted. The 30 in. diameter sections are extended to a 30 in. x 60 in. transition plate on each end of the mode cleaner tubes. This transition plate connects directly to the HAM flanges.
9. The four (4) cone style view port adapters, as depicted in view "C-C", of LIGO Spec. E940002-02-V, Figure 4, have been changed to a flat flange plate style. Details of these can be seen on dwg. V049-4-A15 & A1. The flat plate concept will allow more viewing area. Note that on A15 the size of the view ports are in 4" in. tube on a 56" dia. circle because of the 60.5" ID nozzle on the BSC. On A1, the view ports are 8 in. O.D. tube on a 60 in. dia. circle.

10. The HAM 75 l/s annulus ion pumps are located on top of the HAM chambers to free up floor space. For details, refer to dwg. V049-4-054.
11. The BSC 75 l/s annulus ion pumps are located on the upper half of the BSC. For annulus tubing layout on the BSC chamber, refer to dwg. V049-4-025.
12. The 25 l/s annulus ion pumps for the gate valves are located on the gate valve bonnet. The 75 l/s pumps for the beam tube manifold annuli will be supported near grade adjacent to the beam tube manifold. For details of the 25 l/s pump/manifolds, refer to dwgs. V049-4-108 and 110. For details of the 75 l/s pumps, refer to dwg. V049-4-078.
13. The mode cleaner tubes have had a third central support point added which limits the amount of axial thermal movement into the bending type supports. This has created the need for an additional bellows in the 30 in. section near the vertex end. This was approved by LIGO in Change Order No. 19.

3.1.1.2 Washington Right Mid Station

Reference PSI drawing V049-5-004, V049-5-017, V049-5-018 and V049-5-019.

The equipment has been arranged per Figure 7 of specification LIGO-E940007-02-V, Rev. 2. The Final Design Review drawings reflect the following updates to the original scope drawings.

1. Access spools WBE-4C and 4E, 36 in. long, are located on the beam tube end of each 80K pumps, allowing access to the 80K pump and the welded-in-place gate valves.
2. The elevation of the floor surface was lowered 3 in. This gives 73 in. between the floor surface and the beam tube axis centerline.
3. The Main Ion pumps are mounted on top of the 72 in. dia. beam tube manifold on spool A-7.
4. The mechanical room was enlarged to accommodate the PSI vacuum support equipment. An additional personnel door was added for direct access to the vacuum support equipment from the LVEA. The HVAC equipment was moved to a separate room when the size of the mid-station building was increased.
5. The vacuum support equipment room houses the main turbo backing pump, the Class 100 air skid, an electrical cabinet, and the building potable water storage tank. An outside access door 8 ft. wide x 10 ft. high has been added to the mechanical room.
6. The string of chamber and beam tube manifold components between the BSC and the beam tube interface point, shown as 11m 50 cm long in fig. 7, has been detailed identical to the similar string of components shown at the end station in fig. 6.
7. The LN₂ systems have separate storage tanks at each end of the building. The piping runs between the 80K pumps and the storage facilities have been arranged to be nearly identical.
8. The LVEA egress door to the outside was moved from the left side of the building, to the right side. This allowed the piping and electrical wireway between the LVEA and vacuum support equipment room to be routed and supported low in elevation off the floor.

Washington Left Mid Station

Reference PSI Drawings V049-5-006, V049-5-026, V049-5-027 and V049-5-028.

The Left Mid Station is a mirror image of the Right Mid Station.

3.1.1.3 Washington Right End Station

Reference PSI drawings V049-5-005, V049-5-021, V049-5-022 and V049-5-0

The equipment has been arranged per fig. 6 of specification LIGO-E940002-02-V Rev. 2. The Final Design Review drawings reflect the same updates as stated above in the mid station with the following differences:

1. The end station has one 80K pump and one LN₂ storage facility.
2. The building has been enlarged to be the same size as the mid station.

Washington Left End Station

Reference PSI Drawings V049-5-006, V049-5-026, V049-5-027 and V049-5-028.

The Left End Station is a mirror image of the Right End Station.

3.1.2 Utilities

Utilities for electrical power, cooling water and instrument air are provided by the building contractor. The requirements for each of these utilities are defined in the attached documents which can be found in Attachment 4.

Utility	Document Number
Electric Power	V049-1-047
Cooling Water	V049-1-010
Instrument Air	V049-1-043

3.1.2.1 Electrical

LIGO will provide 480/277 V, 3 phase, 4w and 208/120V, 3 phase, 4w panelboards at all of the Corner, Mid, and End stations. This will allow LIGO to properly select electrical and distribution equipment based on available-fault currents and to coordinate overcurrent protection devices.

Electrical equipment provided by PSI is based on the available electrical fault current not exceeding 14,000A RMS on 480/277V systems and 10,000A RMS on 208/120V systems.

Electrical design is also based on the following:

A pipe bridge between the mechanical room and vacuum equipment area will be used by PSI for installing power and instrument cable trays.

Where wiring is not in cable trays, PSI is providing electrical metallic tubing (EMT) with set-screw fittings at indoor locations and in rigid metal (RMC) or intermediate metal (IMC) conduit at outdoor locations. Refer to Electrical and Instrument Construction Specification V049-2-022, Rev. 0, which can be found in Attachment 4.

Electrical loads and circuit breaker sizes are summarized in document number V049-1-047, which can be found in Attachment 4.

3.1.3 Interfaces To Building And Utilities

3.1.3.1 Electrical Interface To Buildings

Reference PSI Drawings V049-3-101, V049-3-102, V049-3-103 and V049-3-104, Instrument Plans WA Corner Station.

The instrument plans depict the location of all instruments that are field mounted. Instruments that are not integral to the vacuum equipment are mounted using industry standard 2" dia. pipe standards. The pipe stands are anchored to the concrete pad at outside locations. The pipe stands are mounted to the cryopump support at indoor locations. For instrument installation details reference PSI Drawing V049-3-008.

Reference PSI Drawings V049-3-106, V049-3-107, V049-3-108 and V049-3-109, Cable Tray Plans WA Corner Station.

The cable tray plans depict cable tray installed throughout this station. The trays are installed overhead at the mechanical room, on the pipe bridge between the mechanical room and the vacuum equipment and on the pipe supports under the vacuum equipment. There are two cable tray systems. One system is for the main ion pump power cables (7,000 volts). This tray system is labeled on the side, "Danger High Voltage". The other tray system is for instrument and control cables (24V max). For cable tray details, reference PSI Drawing V049-3-110.

Reference PSI Drawings V049-3-111, V049-3-112, V049-3-113 and V049-3-114, Instrument Electrical Plans WA Corner Station.

The instrument electrical plans depict field routed conduit and cable channel to instrument/control devices as well as the high voltage cable to the main ion pumps. The conduit and cable channel are used to run conductors from the cable tray to their associated devices. At indoor locations, 2" cable channel houses the ion pump cables, and electrical metallic tubing with set screw fittings will be used for all other conductors. At outdoor locations, rigid metal conduit with threaded fittings supports the conductors. For instrument electrical installation details, reference PSI Drawing V049-3-007.

Reference PSI drawings V049-3-116, V049-3-117, V049-3-118, V049-3-119 and V049-3-124, Power Plans WA Corner Station (4 Dwgs) and Stub-Up Plan WA Corner Station (2 Shts).

The stub-up plan depicts the locations where the vacuum equipment requires LIGO supplied power. Conductors, provided by PSI, are run in underground conduit from the power distribution panels to the locations where the vacuum equipment requires power. Underground conduit and distribution panels are provided by LIGO. At each

stub-up location, intermediate metal conduit (10" - 15" long) with threaded fittings is installed between the stub-up and required receptacle(s). Receptacles are supplied by PSI. For installation details, Ref. PSI Drawing V049-3-006. The power plans depict all electrical device connections. The connections that are not directly associated with underground conduit and are at indoor locations are fed using conductors run in electrical metallic tubing with set screw fittings. At outdoor locations, rigid metal conduit with threaded fittings will be used for all conductors.

Reference PSI Drawings V049-3-133, V049-3-134, V049-3-135 and V049-3-136, Grounding Plans WA Corner Station

PSI is providing grounding lugs on the beam tube and vessel support legs. The grounding plans depict the location of these lugs on the equipment. These points of connection are bonded to the existing ground grid. The ground grid is provided by LIGO. The grounding conductor is #2/0 green. For grounding details, reference PSI Drawing V049-3-009.

WA Mid Stations

Reference PSI Drawings V049-3-201 and V049-3-301, Instrument Plans WA Mid Stations.

Reference PSI Drawings V049-3-202 and V049-3-302, Cable Tray Plans WA Mid Stations.

Reference PSI Drawing V049-3-203 and V049-3-303. Instrument Electrical Plans, WA Mid Stations.

Reference PSI Drawings V049-3-204, V049-3-205, V049-3-304 and V049-3-305, Power Plans WA Mid Stations and Stub-Up Plans WA Mid Stations.

Reference PSI Drawing V049-3-209 and V049-3-307, Grounding Plans WA Mid Stations.

Refer to Section 3.1.3.1. for installation and other information.

WA End Stations

Reference PSI Drawings V049-3-401 and V049-3-501, Instrument Plans WA End Stations.

Reference PSI Drawings V049-3-402 and V049-3-502, Cable Tray Plans WA End Stations.

Reference PSI Drawings V049-3-048 and V049-3-503, Instrument Electrical Plans, WA End Stations.

Reference PSI Drawing V049-3-404, V049-3-405, V049-3-504 and V049-3-505, Power Plans WA End Stations and Stub-Up Plans WA End Stations.

Reference PSI Drawing V049-3-409 and V049-3-509, Grounding Plans WA End Stations.

Refer to section 3.1.3.1 for installation and other information.

A junction box is located at each backing pump. A similar box is located at each pumpout port. The wiring between the two is such that a backing pump for a main roughing cart can only be used with one roughing cart at a time. The turbomolecular pump cart with backing pump cart are arranged similarly.

3.1.3.2 Mechanical Interface to Buildings

Mechanical interfaces between the Vacuum Equipment and building are defined on the referenced drawings. These interfaces are consistent with the information previously provided to LIGO in PSI document V049-PL-104.

WA Corner Station

Reference PSI drawings V049-5-001 and V049-5-012.

1. Location of PSI tie-in to 3 in. cooling water supply and return.
2. Location of PSI tie in to 1 in. Instrument Air Header.
3. Air dryer blow down exhaust - 1/2" dia. with sleeve (by PSI).
4. Location of floor drain in mechanical room.
5. Location of 6" air inlet wall penetration to V.E. air compressor, through wall to the LVEA room.
6. Location of piping/electrical wall penetrations "A" between LVEA pipe bridge and the mechanical room.
7. Location of wall penetrations "B", between the LVEA and the LN₂ storage area outside. This is typical for both right and left arms.
8. Location of HVAC exhaust duct in the area of the vacuum backing pump exhausts.

WA End Stations

V049-5-017, V049-5-004 and V049-5-026

1. Location of PSI tie-ins to 2 in. cooling water supply and return headers.
2. Location of PSI tie in to 3/4 in. instrument air headers.
3. Air dryer blow down exhaust - 1/2" dia. with sleeve to outside (By PSI).
4. Location of floor drain in vacuum equipment support room.
5. Location of 4 in. air inlet wall penetration to V.E. air compressor, through the wall to the LVEA room.
6. Location of piping and electrical wall penetration "A" and "C" between LVEA room and vacuum equipment support room.
7. Wall penetration "B", between the LVEA and the LN₂ storage area outside. This is required on both ends of the Mid Station buildings.

WA Mid Stations

Mechanical Interface to Buildings

Reference PSI drawings V049-5-005, V049-5-021, V049-5-007 and V049-5-030.

The following building interface requirements have been sent to LIGO and the Building Contracts.

1. Location of PSI tie in to 2 in. cooling water supply and return headers.
2. Location of PSI tie in to 3/4 in. instrument air header.
3. Air dryer blow down exhaust - 1/2" dia. with sleeve to outside (By PSI).
4. Location of floor drain in Vacuum Equipment Support room.
5. Location of 4 in. air inlet wall penetrations to V.E. air compressor, through the wall to the LVEA.
6. Location of piping and electrical wall penetration "A" and "C" between LVEA and the Vacuum Equipment Support room.
7. Wall penetration "B", between the LVEA and the LN₂ storage area outside. This is required on one end of the End Station Building.

3.1.4 Interfaces To Process Control System

When reviewing this section, reference can be made to the following drawings:

V049-3-123	5 Shts	CDS Interface Diagram Corner Station
V049-3-208	2 Shts	CDS Interface Diagram Left Mid Station
V049-3-308	2 Shts	CDS Interface Diagram Right Mid Station
V049-3-408	2 Shts	CDS Interface Diagram Left End Station
V049-3-508	2 Shts	CDS Interface Diagram Right End Station

3.1.4.1 WA Corner Station

Reference PSI Drawing V049-3-123, CDS Interface Diagram.

This drawing depicts all the instrument/control inputs and outputs being wired directly to the CDS racks. These racks are supplied by LIGO. A control transformer is required at each rack. The control transformer is provided by PSI.

I/O Count WA Corner Station

Digital Inputs: 58

Digital Outputs: 60

Analog Inputs: 82

Analog Outputs: 4

T/C Inputs: 6

3.1.4.2 WA Mid Stations

Reference PSI Drawings V049-3-208 and V049-3-308, CDS Interface Diagram.

These drawings depict all the instrument/control inputs and outputs being wired directly to the CDS racks. These racks are supplied by LIGO. A control transformer is required at each rack. The control transformer is provided by PSI.

I/O Count WA Right Mid Station

Digital Inputs: 22

Digital Outputs: 21

Analog Inputs: 25

Analog Outputs: 4

T/C Inputs: 6

* I/O Count For the Right And Left Mid Stations Are Identical.

3.1.4.3 WA End Stations

Reference PSI Drawings V049-3-408 and V049-3-508, CDS Interface Diagram.

These Drawings depict all the instrument/control inputs and outputs being wired directly to the CDS racks. The racks are supplied by LIGO. A control transformer is required at each rack. The control transformer is provided by PSI.

I/O Count WA Right End Station

Digital Inputs:	13
Digital Outputs:	13
Analog Inputs:	16
Analog Outputs:	2
T/C Inputs:	3

* I/O Count For the Right And Left End Stations Are Identical.

3.2 Vacuum Enclosure

3.2.1 Design

The basic design approach of all the pressure vessels and beam tube modules uses the ASME Boiler and Pressure Vessel Code, Section VIII, Div. 1 as a guideline. Vessels that function under vacuum do not technically fit within the scope of the Code, however, every attempt was made in our design to meet the intent of the Code. For some components, the design rules of Sect. VIII, Div. 2 are used where Div. 1 rules are not appropriate.

Under normal design conditions following Par. UG-37 of the Code, openings in vessel walls will be integrally reinforced without the addition of reinforcement pads if the vessel wall is made to be 1.5 times the required thickness for external pressure loads only. However, certain locations on the BSC and HAM vessels have openings whose size and spacing fall far outside the limits set by the Code and must be handled differently (per Par. U-2). For these instances when it was determined that Division 1 of the Code did not adequately address the design considerations, a detailed finite element stress analysis of the area in question was performed. Models were created to demonstrate that combined bending and membrane stresses in the shell and more specifically at the shell to nozzle intersection are within code accepted values. By means of thickened shell sections, thickened nozzle sections, and exterior stiffeners, we were able to effectively reduce stress limits to acceptable levels. Stress contour plots of these areas were created and are included in the calculations provided. For the upper section of the BSC vessel, a stainless steel external stiffener has been added to the shell to reinforce the vessel.

Tubular components, such as mode cleaner tubes, beam tube manifolds, and adapters have been designed using thickness requirements of the ASME Code, Section VIII, Div. 1. These are based on the external design pressure. Most tubes are 1/4 in thick and include ring stiffeners that are spaced to meet code requirements for the external pressure.

Nozzle welds, that vary slightly from the standard nozzle connection details shown on Fig. UW-16.1 of the ASME Code, have been designed to improve vacuum performance. Some of the features of the connection details common among industry accepted vacuum design and fabrication practices include minimizing weld sizes while retaining structural integrity, penetration welding from the inside surface, and stitch welding outside surfaces. We believe these details are necessary in order to reduce heat distortion. Alternative configurations of the welded connections have been evaluated and their structural integrity has been confirmed.

Bolted flanges at nozzles and removable shell sections have been designed for positive internal pressure in accordance with Appendix Y of the ASME Sec. VIII, Div. 1 Code. Since this design section does not include rules for external pressure or vacuum, an alternative analysis using the finite element method was employed. Tensile forces tend to separate flanges and reduce the effectiveness of the seals. Designs of bolted flanges account for the tensile forces that can occur in the system during normal operation and when gate valves are closed.

Gasket seating forces for the self energizing o-rings are essentially zero. Smaller flanges will have Conflat flanges. Our design approach for flange details, was similar to that for the nozzle connections. That is, we modified the ASME details of Appendix 2, Fig 2-4 to provide the best design for vacuum service, while still meeting the basic intent of the Code, specifically as it applies to structural integrity.

The vacuum system is designed using flanges with dual Viton o-ring seals and an annular pump-out channel. This design provides the best performance from an operational consideration and also allows us to utilize the best alternatives for fabrication, shipping, maintenance, etc.

Drawing V049-4-019 shows a typical bolted flange with o-rings and pumping ports. Bolt spacing for the flanges was selected on the basis of structural considerations as well as the recommendations of the gasket vendors for optimum performance. Keeping in mind future service and maintenance requirements the minimal number of bolts were used. This will allow opening of access ports, dome section, etc. to be performed as efficiently and quickly as possible. Detailed finite element analyses of the bolted flanges demonstrate that seals are maintained under all loading conditions.

Expansion bellows will be provided between axial restraints to permit thermal expansion of the system during the bakeout condition. These will be supplied with tie rods that will allow easy installation and removal of these large diameter joints. The tie rods can be used to compress the joint for servicing Viton O-rings. A typical bellows and tie rod assembly is shown on Dwg. V049-4-A1. Tie rod assemblies have been designed to allow removal of tie rods after installation.

Spools and adapters have been designed using flat plate transitions between apertures of different diameters. These plates are 1 in thick stainless steel, SA240, type 304L. Where these transition plates are also used as bolted flanges, the material is SA182, type F304L. Finite element analyses were performed to confirm the flexural resistance of these plates at the discontinuities with the attached shells. For most adapters, these plates are part of the bolted flange.

Vessel supports have been designed to withstand the most severe load combinations for the following conditions:

1. Operating pressures including unbalanced vacuum load
2. Bakeout/thermal expansion
2. Vessel dead and live loads
3. Lateral seismic forces
4. Shipping

The axial restraints are designed for full vacuum load where a gate valve is attached to a tube or component. Flexible supports are attached to tubes and adapters to facilitate thermal expansion. These are designed for combined loads resulting from axial thermal expansion of tubes, downward component weight load and lateral seismic forces. This design concept was selected as an alternative to sliding supports which can be sources of vibration and noise.

Seismic loads were calculated in accordance with ASCE 7-88. For the Washington and Louisiana sites, accelerations were based on Seismic Zone 1.

Vessel supports outside the limits of the ASME boundaries were designed in accordance with the American Institute of Steel Construction (AISC) "Manual of Steel Construction - Allowable Stress Design" 9th edition. Anchor bolts and base plates have been sized using carbon steel properties and a concrete compressive strength of 3,000 psi at 28 days. The concrete anchors will be the drilled-in type that are fastened to the cured concrete. Hilti HVA adhesive anchor were selected.

Material properties used for vessels, cryopumps, beam tube manifolds, and mode cleaner tubes were taken from the ASME Code, Sect. II, Part D at a design temperature that corresponds to the worst case thermal condition. Material properties for structural steel were taken from the AISC manual.

3.2.1.1 Beam Splitter Chamber

The design of the Beam Splitter Chambers (BSC) consists of a 265 cm (104.5 in.) inside diameter upper major access section approximately 154 cm (60.5 in.) long. This section is made up of a 304L stainless steel shell stiffened by means of a rolled stainless steel angle. The top head is an ASME flanged and dished (F&D) section supplied with lifting lugs. The bottom section of the BSC is also a 265 cm inside diameter shell with a bottom ASME F & D head. However, this section of shell has numerous openings for laser beam access, support beams, electrical feedthroughs, etc. This section is made up of a 304/304L stainless steel shell with external stainless steel stiffeners. These stiffeners have been located around nozzles to reduce the shell stresses to within ASME Sect. VIII allowables. Access nozzles "C" will be supplied with ASME F&D heads, as required, and bolted flanges for easy removal. The vessel will be supported by carbon steel legs anchored to the concrete floor slab using Hilti HVA adhesive anchors or equivalent.

The BSC shell will be constructed of material that meets both the high strength properties of 304 stainless steel and the low carbon content of 304L stainless steel. A stress contour plot of the BSC lower shell, from the finite element analysis, is shown in Doc. No. V049-1-022. The maximum stress intensity, 23.5 ksi, is at the junction of the 60.5 in nozzle and the shell. It is less than the limit of 3Sm for primary plus secondary stress range of 56.1 ksi.

A removable aluminum floor has been designed for the BSC to facilitate installation and maintenance of the optical equipment. The floor will be constructed of SB 221, 6061, T6. It will be anchored to the BSC vessel internal structure using screw fasteners. The floor is shown on PSI Dwg. V049-4-036.

Vessel dimensions, nozzle sizes, nozzle locations, and internal details are per Specification LIGO-E940002-02-V Fig. 8 & 12. Drawing. V049-4-001, Sheets 1 to 5, shows the final configuration of the BSC. For the final design, some nozzles have been moved, with LIGO approval, to increase the ligament material between nozzles thereby providing greater strength and stiffness. Access doors on large diameter nozzles are shown on PSI Dwg. V049-4-014.

3.2.1.2 Horizontal Access Module

The Horizontal Access Module (HAM) is a 213 cm (84.25 in.) I. D. horizontal vacuum vessel. The heads for the HAM access covers are ASME F&D heads with bolted flanges and 10-20 cm nozzles for observation ports. The shell section is type 304/304L stainless steel stiffened in two areas by means of stainless steel angles to bring stress levels to within ASME Sect. VIII allowables. Lifting Lugs are attached to stiffeners located on the top section of the shell and positioned to allow the vessel to hang vertically when lifted. The stiffened support saddles are attached to wear plates which in turn are attached to the vessel shell. The support saddles will be bolted to the concrete floor slab using the Hilti HVA concrete anchors. One Laser Beam nozzle (B) will be supplied with a bellows type expansion joint to provide flexibility for thermal movements and to allow O-ring maintenance. Tie rods will be included to compress the bellows for this purpose.

The HAM shell will be constructed of dual grade 304/304L stainless steel material which meets both the high strength properties of 304 stainless steel and the low carbon content of 304L stainless steel. A stress contour plot of the HAM shell, is shown in Doc. No. V049-1-039. The maximum stress intensity, 28.6 ksi, is at the junction of 60 in nozzle and the shell. It is less than the limit of 3Sm for primary plus secondary stress range of 56.1 ksi.

Vessel dimensions, nozzle sizes, nozzle locations, and internal details are per Specification LIGO E940002-02-V Fig. 9 & 12. Drawing V049-4-002, Sheets 1 to 5, depicts the final HAM design.

3.2.1.3 Beam Tube Manifolds/Adapter Spools

Beam tube manifolds consist of 183 cm (72.25 in.) inside diameter rolled sections of varying length. Material for the beam tube manifolds is 1/4 in thick, 304/304L stainless steel. The beam tube sections will be stiffened by means of external stainless steel angles located to minimize material and provide the most cost effective design. Flanges for beam tube sections have been located to provide space for future components. Flanges have also been designed to act as vacuum stiffeners. Manifolds will be supported by means of tube steel type supports located at stiffener rings. The flexible support will allow thermal expansion, but it will support the weight of the manifold and restrain it against lateral seismic acceleration. The bellows expansion joint allows free thermal motion during bakeout.

Some manifold/spool sections have flanges on one end with slotted holes. During installation, this feature corrects minor hole pattern tolerance stack-up.

Beam tube manifold dimensions, lengths, and details conform to the requirements of LIGO specification E940002-02-V Rev 2. These are shown on PSI V049-4 series drawings.

3.2.1.4 Mode Cleaner Tubes

Mode cleaner tubes consist of 76 cm (30.5 in.) inside diameter rolled sections of varying length. Material for the mode cleaner tubes will be 304/304L stainless steel. The tube sections will be stiffened by means of external stainless steel angles similar to the beam tube manifolds. Supports for the cleaner tubes will be similar to the beam tubes. The flexible supports and bellows allow thermal expansion during bakeout.

Mode cleaner tubes dimensions, lengths, and details are per Spec. LIGO E940002-02-V Fig. 4 and 5. These are shown on V049-4 series drawings. The design includes flanges featuring dual Viton O-rings and a pumped annulus space.

3.2.1.5 80K Cryopumps (Vacuum Enclosure)

The 80K Cryopumps will be provided in 2 versions. The long pump vacuum enclosure is an 80 in. inside diameter by 146 in. (T/T) shell made of SA 240, type 304/304L. The ends are reduced to a 44 5/8 in. inside diameter section using ASME F&D heads. The shell is stiffened by means of stainless steel rolled angles. The short pump vacuum enclosure is an 80 in. inside diameter by 48 in. (T/T) shell. The ends are reduced to 44 5/8 in. inside diameter sections. Thickness of the various parts of the cryopump outer shell are based on ASME Code requirements.

Supports for each model cryopump consist of vessel legs attached to stiffener rings on the vessel shell. Legs are carbon steel (A500 Grade B tube steel). The pair of legs that serve as longitudinal restraints against the vacuum load on a closed gate valve are diagonally braced longitudinally. The other pair of legs are flexible members that allow thermal expansion during the bakeout condition. Legs will be insulated to minimize heat leak during bakeout.

The pump reservoir is an aluminum inner vessel (SB209, 6061, T651) in the 80K pump that is designed for the worst combination of pressure and temperature. One-half inch stainless steel rods support the weight of the reservoir and restrain it against lateral and longitudinal seismic accelerations. Springs are included in the support rods and restraints to mitigate vibrations from the pump reservoir to the outer shell. The pump reservoir, which contains boiling nitrogen, was designed in accordance with the ASME Code for worst case load combinations.

Since gate valves are located at each end of the 80K cryopump, there is a possibility of overpressurization due to malfunction during the regeneration cycle. To mitigate the consequences of this condition and prevent a rupture, a pressure relief device has been designed for the outer shell. This device will maintain the vacuum seal but it will open before substantial positive pressure is attained in the outer shell.

The 80K cryopumps are shown on Drawings V049-4-004 and -005.

3.2.1.6 Common Items

3.2.1.6.1 Materials

Unless specified otherwise, the following materials will be used for the design and fabrication of the items listed:

1.	BSC and HAM Shells	SA	240	304/304L	
2.	Beam Tube Manifolds	SA	240	304/304L	
3.	80K Cryopump (Vacuum Boundary)	SA	240	304/304L	
4.	Mode Cleaner Tube	SA	240	304/304L	
5.	Bolted Flanges	SA	182	304L	
6.	Flange Bolts	SA	193	B7	
7.	External Stiffeners	A	479	304	
8.	Supports	A	36 or	A500	Gr B
9.	Expansion Bellows	SA	240	304L	
10.	Gate Valves	SA	240	304L	
11.	Adapters/Spools	SA	240	304/304/L	
12.	Conflat Flanges			304L	
13.	BSC Removable Floor	SB	221	6061	T6
14.	80K Pump Reservoir	SB	209	6061	T651

All plate and forgings will be supplied as hot rolled, annealed and pickled, with a standard mill finish. Detailed descriptions of the materials can be found in the following specifications located in Attachment 5.

Plate	V049-2-041
Heads	V049-2-039
Flange Forging	V049-2-040
Conflat Flanges	V049-2-037

Only new material meeting the specified ASTM or ASME designation will be used. These materials are intended for use in a high vacuum application. All potential sources of hydrocarbon contamination will be eliminated. Also, wherever possible, the material will be wrapped and covered at all times that such materials is not being processed in order to minimize possible exposure to contaminants.

3.2.1.6.2 Cleaning

The preliminary design effort included confirmation of CEBAF test results using XPS analysis to measure the surface contamination. It confirmed the effectiveness of simple detergent cleaning. Further investigation showed that the use of ultrasonic baths (typically used for vacuum components) for pieces as large as the BSC lower section were impractical. The reasonable choices were manual washing using nylon brushes, or automatic pressure spray washing. Pressure spray washing was selected as providing the desired washing turbulence and repeatability, especially when done in a machine with an automatic cycle.

The use of pressure sprays, however, limited the detergent choices, since one of the prime selection criteria was the need for a non-sudsing compound. Six candidates were tested and coupons were analyzed by XPS. The ultimate test, however, is an RGA test of the 10" prototype unit under vacuum. This, along with other considerations (e.g., corrosiveness and disposal issues) leads to the final selection.

The following are descriptions of the six detergents tested. All were represented as being biodegradable and low sudsing, although the Fisan Versagen proved to produce heavy foam.

A. 217 Pressure Wash (Manufactured by Chesterton).

The main ingredient is dipropylene glycol monomethyl ether with no silicates. The recommended concentration is 4-10%, resulting in a pH of 10.2. The material is non-hazardous, but produces some skin irritation.

B. Inpro-Clean 1300 (Manufactured by Oakite).

The main ingredient is potassium phosphate with some proprietary hydrocarbons but no silicates. The recommended concentration is 5%, resulting in a pH of 9.8. The material produces some skin irritation.

C. Fisan Versagen (Manufactured by Oakite).

The main ingredient is dipropylene glycol monomethyl ether with other hydrocarbons, but no silicates. The recommended concentration is 4%, resulting in a pH of 8.5. The material produces some skin irritation.

D. Chem-Klean HPS (Manufactured by Leander).

The main ingredients are KOH, glycol and ethanalamines with no silicates. The recommended concentration is 5-10%, resulting in a pH of 10.1. The material is non-hazardous, but produces some skin irritation.

E. Det-O-Jet (Manufactured by Alconox).

The main ingredient is KOH with no silicates. The recommended concentration is 3.2%, resulting in a pH of 13. The material is corrosive.

F. Hazzit (Manufactured by Diversey).

The main ingredients are potassium metasilicate and pyrophosphate. The material is corrosive.

XPS analysis of test coupons showed relatively high oxygen and low carbon for detergents B (Impro-Clean 1300) and E (Det-O-Jet). Impro-Clean 1300 was selected as the primary candidate detergent. It was used on the 10" prototype vessel and again on the BSC prototype with excellent results.

3.2.1.6.3 Welding

The specification requires welding by TIG with inert gas purging to avoid contamination of the heat affected zone. All vacuum welds are to be continuous on the vacuum side with stitch welding on the external surfaces in accordance with good high vacuum practice. These welding procedures are routine at PSI. Weld procedures are in place for both ASME and high vacuum requirements. Welders are certified on a regular basis.

Project specific weld details and procedures have been developed based on the use of plasma welding. Plasma arc welding, an enhanced form of TIG was investigated and selected for use because it provides improved control of the weld penetration. The result is less power is required resulting in reduced distortion, an important benefit for fabricated vessels with tight dimensional tolerances. As part of this development PSI has purchased two plasma welding machines, and has been qualifying welders and weld procedures per ASME Section IX.

The weld design details and procedures will be verified in the construction of the Prototype BSC. Weld procedures are included in Volume III, Fabrication.

3.2.1.6.4 Alignment and Dimensions

The procedure defining the method of establishing the beam tube, vacuum vessels, cryopumps, etc. alignment during construction activities and through final alignment after bakeout and testing includes a positioning system consisting of alignment lasers, targets, and all the necessary supporting computer software and hardware. The exact procedure is a function of the positioning system manufacturers recommendations, but will be in complete conformance with the concepts and procedures adopted by Cal Tech and the LIGO Project Safety Manual. Initial survey bench marks from which PSI's alignment and positioning will be measured will be provided by others.

Vacuum vessels, cryopumps, beam tube manifolds, and mode cleaner tubes will be aligned vertically to within acceptable limits by means of wheeled jacks positioned under supports or under clips that have been attached to the supports. See attached Figure 3.2.1.6.4. Once the item is properly positioned, the hole locations will be marked, the vessel moved aside and the holes core drilled. The vessel will then be repositioned and grouted in place. (See Volume IV for full installation details.) After the component is locked in place, the jacks can be removed. The use of this system will allow easy adjustment during installation. Horizontal adjustment will be permitted by a combination of oversize holes, drilled-in concrete anchors, and a jacking system attached to a structural anchor. Flanges of adjacent components and spool pieces will be aligned using removable drift pins that will be inserted into bolt holes.

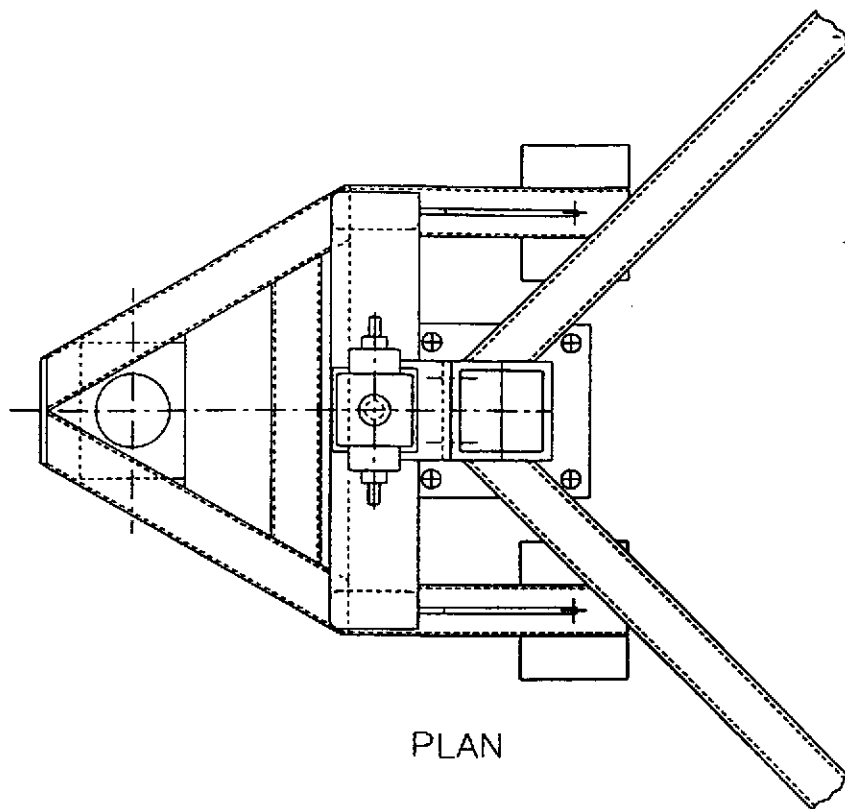

PLAN

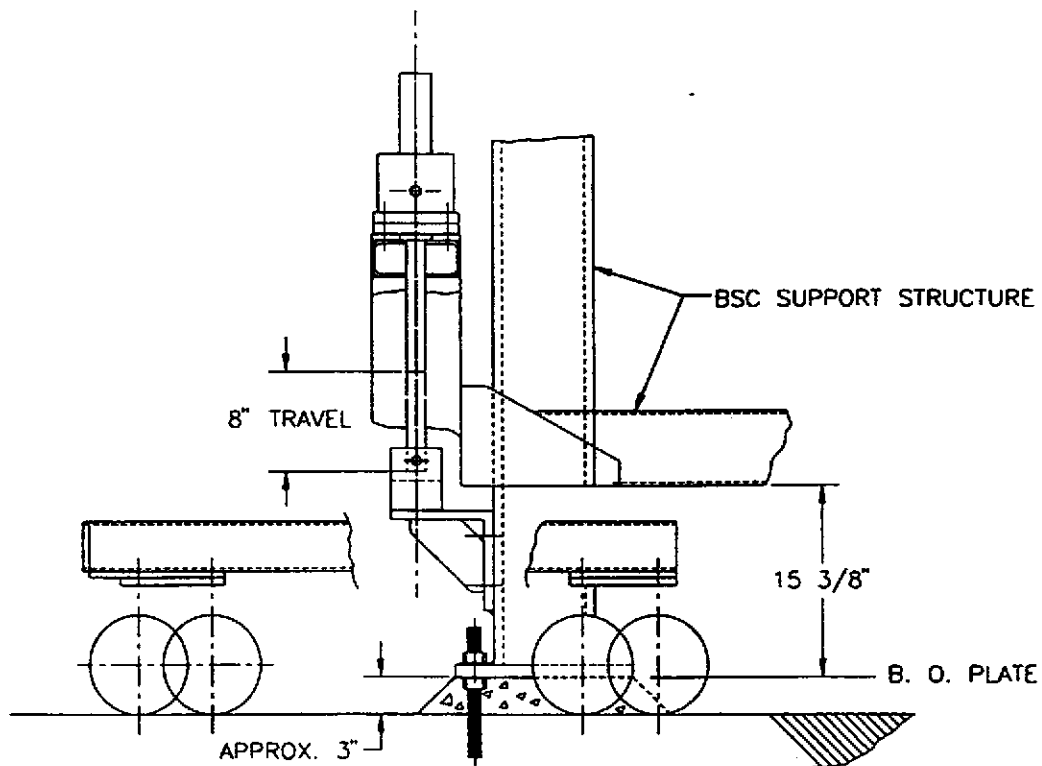

ELEVATION
CHAMBER JACK CONCEPT

SCALE: 1/16" = 1"

FIGURE 3.2.1.6.4

CAD NO. 469E900F

3.2.1.6.5 Mechanical Loads

An analysis of the vacuum system has been performed to determine the component interface loads resulting from equipment operation and bakeout. The analysis considers unbalanced vacuum loads resulting from closed gate valves (vented on one side) and the location of bellows expansion joints which do not transmit axial forces. Mechanical loads obtained from this analysis of the system were evaluated for their effects on the bolted flanges. Also, these loads were used to design axial restraints.

In addition to operating mechanical loads, the vacuum equipment has been designed for concurrent weight and seismic loading in accordance with ASCE 7-88.

3.2.1.6.6 Flanges and Ports

Flanges for the BSC vessels, HAM vessels, beam tube manifolds, and mode cleaner tubes are shown in detail on the appropriate chamber or tube drawings. Generally, flanges for nozzle sizes 36 cm (14 in.) and smaller will be CF type (using copper gaskets). For nozzles and beam tubes of larger diameter, flanges are custom designed. The vacuum seal for these flanges utilizes a dual o-ring design. The dry Viton (registered trademark, Dupont Inc.) O-rings are vacuum baked prior to installation in order to remove potential sources of offgas. These flanges have an annular channel between the two o-ring seals. These annular channels are manifolded to a pumpout port leading to an ion vacuum pump. Flanges are designed in accordance with Appendix Y of the ASME Sec. VIII Code for positive pressure. For negative pressure, finite element analyses have been performed to ensure that seals are maintained during equipment operation. Welding of the flanges to the nozzle walls or vessel shells are in accordance with the requirements of the ASME Code and, where required, modified to meet the industry accepted standards for good vacuum practice. Flange material is 304L stainless steel. Bolting for the larger diameter flanges is SA 193 B7. Sealing surfaces are machined to a 32 rms finish with a concentric lay. Flange finish away from the sealing surfaces is 63 rms or 125 rms depending on location. Machining of flanges shall be performed with water soluble industry accepted UHV compatible machining lubricants.

3.2.1.6.7 Flange Annuli

Annulus Channels

To minimize diffusion of gasses from atmosphere through the double Viton o-ring seal, the space between the two o-rings is pumped out and maintained under vacuum using an ion pump. There are six sizes of flange connections which require a double Viton o-ring seal: a 112 cm (44 inch) diameter seal, 122 cm (48 inch) diameter seal, a 152 cm (60 inch) diameter seal, a 183 cm (72 inch) diameter seal, a 213 cm (84 inch), and a 264 cm (104 inch) diameter seal

Diffusion Rate

A diffusion rate of 2×10^{-6} [torr - l/s]·[m/m² ·bar] is used for diffusion of air through Viton. A nominal o-ring diameter of 1/4 inch (6.35 mm) was assumed in the calculation of the amount of gas diffused through the o-rings. The predicted diffusion rate will be on the order of 1×10^{-5} torr - l/s per o-ring

Annulus Pressure And Pumping Speed

To achieve a diffusion rate into the ultra-high vacuum (UHV) side, which does not require a significant pumping speed, on the UHV side, a certain pressure must be maintained in the Annulus space. A diffusion rate per o-ring on the order of 1×10^{-5} torr - l/s -bar and an annulus pressure on the order of 1×10^{-3} torr gives a diffusion rate into the UHV section on the order of 1×10^{-11} torr - l/s. To maintain a pressure on the order of 10^{-4} torr, with a diffusion rate from atmosphere per o-ring on the order of 10^{-5} torr - l/s, the pumping speed must be of order 0.1 l/s.

3.2.1.6.8 Access Connectors

The LIGO specification has requested 90 cm min. length (35.4 in) removable tube sections in the 152 cm dia. tube sections at BSC2 & BSC4, and a similar connector at BSC7 & BSC8.

PSI has incorporated the following access connector spools into the equipment arrangements. Note that each access spool contains an expansion bellows designed for 2 in. of retraction for removal and o-ring maintenance, and has removable threaded tie rods for spool length adjustment, and lifting lugs.

1. Washington Corner Station

- WBE-2A & 2B, 66 1/2" Long, each spool is one piece with an expansion bellows located near one end to allow room for the addition of future side access ports.
- WBE-3B & 3C are 40 3/4" long, each spool is one piece with an expansion bellows and a fixed transition plate which is used to make the 10 cm vertical offset between the BSC and HAM. These are located at BSC2 & BSC4.
- WBE-3A1 & A2 are 40 3/4" long, each spool is made into two pieces with allows removal of one or two pieces while the BSC detector support system is in place. An expansion bellows is included in the longer of the two spools. The 10 cm vertical offset is designed into the middle flange set. One spool is located next to BSC2, and one is located next to BSC4.
- WA-12A & 12B are 46" long, each spool is one piece with an expansion bellows. These are the access connectors for BSC7 & BSC8.
- WA-6A & 6B are 46" long, each spool is one piece with an expansion bellows. These are additional access connectors at BSC4.
- BE-4A & 4B are 36" long, each spool is one piece with an expansion bellows. These spools give access to the 80K pumps and gate valves at the beam tube interface.
- A-1A & 1B are 52" long, each spool is one piece with an expansion bellows. These spools are easily removable for access to the gate valves on the beam tube manifolds.

2. Washington Mid Station

- WBE-4C, 4D, 4E and 4F are 36 in. long, each spool is one piece with an expansion bellows. These spools give access to the 80K pumps and the gate valves at the beam tube interface. The main access to the BSC's is through two access doors.

3. Washington End Station

- WBE-4G and 4H are 36 in. long, each spool is one piece with an expansion bellows. These spools give access to the 80K pumps and the gate valves at the beam tube interface. The main access to the BSC's is through the three access doors. Note, the end access door WA-11A and 11B has one 8 in. O.D. tube port with a 10 in. O.D. conflat blind flange.

3.2.1.6.9 Fasteners

Flange bolts for the large diameter flanges will be SA 193 B7, 7/8 in. 9UNC, with an electrolysis nickel finish. Nuts will be SA 194 B7. Concrete anchors for all vessels, beam tube manifolds, mode cleaner tubes, and skid weldments will be Hilti HVA adhesive anchors which will be installed in cured concrete floors. Bolts used in structural steel fabrication shall be ASTM A325 or A307. For additional, bolting or other miscellaneous fasteners used, refer to individual equipment specifications and drawings.

3.2.1.6.10 Bellows

Bellows expansion joints are placed between components and between the axial restraints of beam tube manifolds and mode cleaner tubes to allow unrestrained thermal expansion during the bakeout condition. Also, bellows facilitate installation and removal of components and spools. Adapters which include bellows also include tie rods that span the bellows. These will be used to compress the bellows for maintenance and component removal. The displacement requirements for bellows are given in Specification V049-2-017.

3.3 Pumps

3.3.1 Main Roughing System

Two different types of vacuum pump sets are used for roughing service. Which types of sets used depends on the location.

In the corner stations where the volumes are large, the roughing system is comprised of both main roughing pump sets and main turbo molecular pump sets.

For the mid and end stations, only turbo molecular pump sets are used.

The main roughing pump sets from the corner stations are also used to evacuate the beam tubes.

The main roughing pump sets are sized to provide a four hour pumpdown from atmosphere to less than 1 torr for an isolated section. The main roughing pump sets are also designed to pump out a 2000m³ volume without overheating.

The main roughing pump set is comprised of two pumps per set. The first stage is a roots type blower which is then backed by a single dry rotary pump. The set is designed for continuous duty oil free pumping at 1 torr and 0.1 torr inlet pressure.

The set will be supplied by Edwards High Vacuum Inc. in accordance with PSI specification V049-2-001, Rev. 3. The following is a brief description of this set:

1 Edwards High Vacuum Model EH2600 Roots Vacuum Pump with the following features:

- Volume flow = 3100 M³/Hr @ 60 Hz
- Gray cast iron body
- Water cooling
- Viton seals
- No oil in pumping path
- Air cooled motor
- Hydrokinetic drive (rotational speed = 0-3500 rpm)

1 Edwards High Vacuum Model EDP200 Dry Backing Pump with following features:

- Nominal volume flow of 300 M³/Hr @ 60 Hz
- Three stage design
- Gray cast iron body
- Temperature controlled coolant jacket (water cooled)

The Edwards standard design for this type of roughing system is a single assembly. PSI, however, is remotely locating the EDP200 dry backing pump in the Mechanical Equipment Room. This will minimize vibration transmission from the backing pump to the VEA.

The 3100 M³/hr roots blower will be coupled to the vacuum envelope by means of a flexible connector. The blower discharges to a 15.2 cm (6 in.) diameter header maintained at 1 torr. This header leads to the backing pump in the Mechanical Equipment Room. The dry backing pump discharges to the building ventilation system.

Safety interlocking is provided on the inlet to the roots blower by means of a pneumatically actuated fail closed gate valve which in the event of a power loss or pump trip will isolate the interferometer from atmospheric exposure.

Vacuum instrumentation includes Pirani and cold cathode gauges at the inlet to the roots blower and a Pirani gauge at the outlet. Manual valves are provided to allow connection of a leak detector.

Utility requirements are as follows:

- 15 liters/min. of cooling water, max. 30 deg. C for cooling each roots blower and dry backing pump
- Roots blower- 7.5 KW
- Dry backing pump- 15 KW
- Instrument air for valve operation and seal gas.

3.3.2 Main Turbomolecular Pump System

The set will be supplied by Edwards High Vacuum Inc. in accordance with PSI specification V049-2-002, Rev. 4. The following is a brief description of this set:

1 Edwards High Vacuum (Seiko) Model STPH 2000C turbomolecular drag pump with the following features:

- 1400 l/s (minimum speed) @ $< 1 \times 10^{-3}$ torr inlet pressure
-
- 5 torr-l/s (minimum thruput) @ 0.1 torr inlet pressure
- Holwek drag stage
- Magnetic bearings with 5 axis active control
- Baked, non-lubricated Viton o-rings

1 Edwards High Vacuum Model QDP80 Dry Backing Pump with the following features:

- Nominal volume flow of 110 M³/Hr @ 60 Hz
- Four stage design
- Gray cast iron body
- Temperature controlled coolant jacket (water cooled)
- Water cooled motor

The Edwards standard design for this type of turbomolecular vacuum system is a single though separable assembly. PSI has remotely located the backing pump in the Mechanical Equipment Room. This will minimize vibration transmission from the backing pump to the VEA.

The turbopump will be closely coupled to the interferometer to maintain high pumping performance. A short bellows between the interferometer and the pump will attenuate vibration from the pump. Vibration isolation mounts on the turbopump and the pump cart are included in the design.

The inlet to the turbopump is a 25 cm. (10") nominal diameter connection. The turbopump will exhaust to a 10 cm. (4") nominal diameter vacuum header maintained at 1 torr leading to the QDP80 backing pump in the Mechanical Equipment Room. The backing pump will exhaust to the building ventilation system.

Safety interlocking is provided on the turbopump discharge by means of a pneumatically actuated fail closed valve which in the event of a power loss or to atmospheric pressure. Controls for local operation are provided. In addition, connections are provided for interface with the future LIGO control system.

Vacuum gauges are located at the inlet and outlet of the turbopump. The inlet to the turbopump has both a Pirani gauge and a cold cathode gauge. The outlet of the turbopump has a Pirani gauge. Manual valves are provided to allow connection of a leak detector.

Utility requirements are as follows:

- 7.6 liter/min. of cooling water for each set
- Turbo- 2 KW
- Backing- 4KW
- Instrument air for valve operation and seal gas

Vibration and noise measurements on the turbopump system will be taken prior to field operation. This data will be included as part of the vibration program analysis.

3.3.3 Auxiliary Turbomolecular Pump System

The set will be supplied by Edwards High Vacuum Inc. in accordance with PSI specification V049-2-003, Rev. 3. The following is a brief description of this set:

1 Edwards High Vacuum Model EXT70H compound turbomolecular pump with the following features:

- Holwek drag stage
- Upper magnetic bearing
- Lower ceramic ball bearing
- No oil in pumping path

1 Edwards High Vacuum (Vacuubrand) Model MD4 diaphragm pump with the following features:

- Viton diaphragms
- No oil in pumping path
- Silencer on outlet

The auxiliary turbo pump system will be mounted on a single cart, and since the volume it needs to rough is very small, it will have completed its function before the main roughing pumps are done pumping. Vibration and noise are therefore not an issue for the auxiliary turbo system.

Since the annular volumes to be evacuated are small, and no oil vapors will be in the discharged air, the turbopump system will discharge directly to the building.

A fail closed pneumatically actuated valve will be provided at the inlet of the pump cart, so that in the event of a power failure, the interferometer annular spaces will not be exposed to atmospheric air. This valve also prevents the annulus from being exposed to a non-operating pump.

Controls for local operation are provided. In addition, connections are provided for interface with the future LIGO control system.

Vacuum gauges are located at the inlets of both pumps. The inlet to the turbopump has both a Pirani gauge and a cold cathode gauge. The inlet to the backing pump has a Pirani gauge. Manual valves are provided to allow the connection of a leak detector.

Utility requirements are as follows:

- Instrument air for valve operation
- 110 VAC, 1 Ph., 60 Hz.

3.3.4

Main Ion Pumps

The main ion pumps will be supplied by Varian Vacuum Products in accordance with PSI specification V049-2-004, Rev. 2. The pumps are installed either on the top of the mode cleaner tubes or the the beam tube manifolds. This arrangement offers the advantage of freeing up floor space around the interferometer. Twelve (12) pumps will be installed at the Washington site, and 6 pumps will be installed at the Louisiana site.

Each pump has 2 electrically isolated sections controlled by 2 individual feedthrus, and a single controller with 2 independent 400 watt high voltage modules. This configuration allows the ion pump to operate as two independent half capacity pumps.

1. Characteristics of the Main Ion Pump Are:

- The minimum pumping speed is 2500 l/s for N₂ at 1×10^{-6} torr, measured in accordance with the PNEUROP test procedure.
- The pump housing is a rectangular stainless chamber measuring 850 mm x 850 mm x 750 mm high, and contains 40 noble diode element assemblies mounted in two rows.
- The weight is 600 Kg \pm 30 Kg.
- The main port is a 16 1/2" OD x 14" ID CFF mounted on the bottom of the pump.
- An additional 8" OD x 6" ID CFF port is mounted on the top of the pump for future use by LIGO.
- A 2-3/4" OD x 1-1/2" ID CFF pumpout port is provided on the top of the pump for roughing the pump
- 4 lifting bolts are provided on top and bottom.
- 2 high voltage (HV) electrical feedthrus are provided per pump. They are controlled individually thru a HV module in the multivac controller.
- Maximum operating pressure is 1×10^{-5} torr.
- The pump is bakeable to 150⁰C
- Minimum operational life is 40,000 hours at operating pressure of 10^{-6} torr.

2. Ion Pump Controller Features Are:

- CAT # Varian Multivac 929-4010S012
- Maximum power is programmable between 10 and 400 W
- 2 HV modules. (One per feedthru)
- 2 HV cables. (One per feedthru)
- Local/remote control
- Front panel display
- 0-10V output current (One per HV module)
- 0-10V output voltage. (One per HV module)
- General fault output. (One per HV module)
- Programmable (Front Panel)
- High pressure shutdown mode
- Fan cooled (Noise source)
- Max operating pressure 1×10^{-6} torr

The controllers are rack mounted in the mechanical rooms. Details of noise and vibration integration measures that PSI has implemented may be found in Section 4.0.

3.3.5 Annulus Ion Pumps

Annulus pumps were sized with due regard to the volumes being maintained at ultra high vacuum, the expected leakage rate, and the requirement for a 40,000 hr. life.

The system based on a 75 L/S noble diode pump for the chamber annuli, and a 25 L/S noble diode pump for the valve annuli. One power supply is provided for every pump. These power supplies require no forced air cooling, and are very small consumers of power, and so are not expected to be of any consequence with regard to noise or vibration.

3.3.5.a. 75 l/s Ion Pump Features Are As Follows:

- CAT # Varian 919-0302S004
- 19 Kg (weight)
- 6" CFF (6" Varian manual valve will isolate the pump)
- 1 1/2" CFF for roughing down the pump
- One HV electrical feedthru
- Maximum operating pressure is below 1×10^{-3} torr
- Ultimate pressure is below 10^{-11} torr
- Bakeable to 350°C
- Operational life, 50,000 hrs at operating pressure of 1×10^{-6} torr
- Pumping speed (nominal): 68 l/s of air at 1×10^{-6} torr

3.3.5.b. 75 l/s Ion Pump Controller Features Are:

- CAT # Varian 929-0191
- Maximum power is 21W
- (1) HV connectors
- (1) HV Cable
- Local/remote control
- Front panel LED bargraph for current and voltage indication
- 0-10V DC, linear proportional to current (10V = 10mm)
- 0-5VDC, linear proportional to HV (1V = 1KV)
- HV on confirm signal
- Maximum operating pressure 1×10^{-5} torr

3.3.5.c. 25 l/s Ion Pump Features Are As Follows:

- CAT # Varian 919-5050S004
- 18 KG (weight)
- 2 1/2" CFF (Varian manual valve will isolate the pump)
- CFF for roughing down the pump
- One HV electrical feedthru
- Max operating pressure is below 1×10^{-3} torr
- Ultimate pressure is below 10^{-11} torr
- Bakeable to 350°C
- Operational life, 50,000 hrs at operating pressure of 1×10^{-6} torr
- Pumping speed (nominal): 25 l/s of air at 1×10^{-6} torr

3.3.5.d. 25 l/s Pump Controller Features Are:

Both 75 and 25 l/s ion pumps are controlled by the same type controller which is shown in Section 3.3.5.b.

3.3.5.e. Corner Station

- Each HAM is served by a single pump. Four flanged pump out ports are manifolded together.
- The flanged beam manifold sections plus the large 183 cm. x 122 cm. flange on each arm are served by a single pump on each arm. The pump out ports are manifolded together and lead to these pumps.

3.3.5.f. Mid Station

- Each BSC is served by a single pump. Five flanged connection pump out ports are manifolded to this pump (Wash. site only).
- The flanged beam manifold sections on each arm are served by a single pump on each arm. The pump out ports are manifolded together and lead to these pumps.

3.3.5.g. End Station

- Each BSC is served by a single pump. The manifolding is similar to the five flanged pump out ports.
- The flanged beam manifold sections on each arm are served by a single pump on each arm. The pump out ports are manifolded together and lead to these pumps.

3.3.5.h. Large Gate Valves

- Each large gate valve has a dedicated pump, serving the valve flanges. A blanked off port is provided for the addition of a future dedicated pump for the gate seal.

Annulus Channel Size

The approximate conduction of the annulus channel and annulus pump out port must be sufficient to maintain a pumping speed on the order of 0.1 l/s throughout the annulus channel. The cross-sectional sizes of the annulus and interconnecting tubing were sized to give a minimum conductance of 0.2 l/s anywhere in the channels. Refer to Document V049-1-012 for annuli system conductance calculations

Annulus Port

The diameter of the annulus pump out port must be large enough to retain the same or larger orifice conductance as the annulus. The diameter used for the annulus flange port is 0.620 inches (15.7 mm).

Pump Size And Capacity

With a diffusion rate on the order of 1×10^{-5} torr - l/s per o-ring, the approximate gas load per pump would be 5×10^{-5} torr - l/s. For a 40,000 hr life, the required ion pump capacity would need to be 7300 torr-L. A typical ion pump has a storage capacity of 144 torr-L per 1 L/s of pumping speed (40,000 hours @ 1×10^{-6} torr.) The pump speed needs to be at least 50 l/s. A pump with a storage capacity equivalent to a speed of 75 l/s is planned. For the 112 cm and 122 cm (44 inch and 48 inch) gate valves, where the quantity of o-rings and sizes are smaller, the pump size selected is a 25 l/s pump. A separate pumpout port is provided for a future pumpout of the gate valve seals

Annulus Pumpout Tubing

The size of the tube that runs from the annulus pump out port to the manifold where the auxiliary turbo pump and ion pump are connected varies from 1 inch to 1 1/2 depending on length and flange size.

Valving

Each chamber manifolded annuli group has an single roughing port 63 mm valve and an 63 mm isolation valve for the Ion pump.

3.3.6 80 K Pumps

3.3.6.1 Design & Operating Principle

Cryopump Design: "Annulus" Design

The "annulus" design is shown in figure 3.3.6.1 and PSI drawing no. V049-4-004. The liquid nitrogen is contained in an annular space created by two cylindrical aluminum surfaces. Because the entire surface of each cylinder is in contact with the boiling liquid, temperature variations across the cryopump surface are minimal. This design can allow for a larger liquid volume, compared to a more typical tube on sheet design, in order to keep the vapor/bubble fraction of the boiling liquid low. Because of the two vessel walls, this design is much heavier than a typical "tube on sheet" design.

	LONG PUMP	SHORT PUMP
Length	3.7 m	1.2 m
Shell 1 I.D.	1.35 m (53")	1.35 (53")
Wall Thickness.	15.9 mm (0.625")	15.9 mm (0.625")
Shell 2 I.D.	1.44 m (56 3/4")	1.30 m (51")
Wall Thickness.	12.7 mm (0.50")	9.5 mm (0.375")
Estimated Weight (empty)	1341 kg (2950 lbs)	398 kg (875 lbs)

Operation

Liquid nitrogen stored at a set pressure is supplied to the 80K cryopump. The cryopump is flooded with liquid nitrogen. Liquid level is maintained in the cryopump by a control valve on the supply line which provides make up liquid from the liquid nitrogen dewar under level control. Heat fluxes are low and nucleate pool boiling occurs. The vapor generated rises to the top and is vented.

3.3.6.2 Heat Load And LN2 Consumption

The heat load on the cryopumping surface is predominantly radiation load. Water condensation loads can be high, but will be very low under normal operation. Water condensation loads at 10^{-7} torr are approximately 0.14 watts at a pumping speed of $150 \text{ m}^3/\text{s}$. At 10^{-4} torr the condensation load would be about 140 watts. The radiation load on the outer surface of the cryopump has been reduced by the addition of a thermal radiation shield. The radiation load on the inner surface of the cryopump has also been reduced by design, but when the inner surface becomes dirty, the heat load will increase.

Inner Surface

Calculations to determine the radiant heat load on the inner surface of the cryopump have been finalized and submitted. These calculations were performed for both the long and short pumps, clean and frosted, with and without the low emissivity ($\epsilon=.06$) liner. Reducing the heat load on the cryopump is desirable in order to minimize the operating costs due to liquid nitrogen consumption, and to minimize the vibration generated from the collapse of nitrogen vapor bubbles when they break the liquid surface. These heat loads are as follows:

Short Pump, clean with liner:	116 watts
Short Pump, frosted with liner:	499 watts
Short Pump, frosted no liner:	980 watts (conservative value from long pump calculation)
Long Pump, clean with liner:	249 watts
Long Pump, frosted with liner:	546 watts
Long Pump, frosted no liner:	980 watts

Outer Surface

Radiant heating on the cryopump from the chamber walls has been calculated as approximately 28 watts/square meter. To further reduce this load, a single aluminum sheet metal thermal radiation shield with an emissivity of .06, has been included in the design. This shield is located in the annular space between the pump reservoir and the pump chamber wall and is allowed to thermally float at a temperature between the reservoir temperature and the chamber wall temperature. A temperature of 269.5K is predicted for a floating shield. These calculations also predict a better performance for a floating one as opposed to one which is thermally grounded to the vacuum chamber wall. Since the shield has been baffled from the beam tube, water vapor will preferentially condense on the cryopump and not on the shield to any significant degree, and so its performance will not be degraded significantly. Calculations predict a reduction in the chamber wall heat load on the cryopump to the following levels:

Short Pump with radiation shield:	64 watts (211 watts without shield)
Long Pump with radiation shield:	176 watts (615 watts without shield)

Dewar Size

To lengthen the time between refills of the LN2 inventory, the system is designed for minimum heat load. In addition to the cryopump and transfer lines, the liquid nitrogen storage vessel is designed for minimum heat leak. If the cryopump surface stays relatively clean the LN2 consumption will remain low. However as the surfaces get dirtier, the radiation loads increase. Thus 90 day storage requirements would be larger for a dirty than for a clean cryopump. The liquid requirements for a dirty cryopump surface that has a low emissivity diffuse-reflective liner in the inlet/outlet tube sections is still modest and would allow the cryopump to operate dirty for the entire 90 days. During a time when initial outgassing of water is high the pump needs to be regenerated more frequently, but once most of the water has outgassed, LN2 requirements remain low.

Liquid nitrogen use has been calculated for the pump with and without the low e liner, and is summarized below:

Consumption (Gal/90 days)

Short Pump, clean with liner:	3,039 (11502 liters)
Short Pump, frosted with liner:	8,330 (31529 liters)
Short Pump, frosted no liner:	14,975 (56680 liters)
Long Pump, clean with liner:	6,493 (24576 liters)
Long Pump, frosted with liner:	10,596 (40106 liters)
Long Pump, frosted no liner:	16,592 (62801 liters)

For the short cryopump a dewar size of 14401 gallons (54508 liters) is to be with a specified net liquid capacity of 10,000 gallons (37850 liters) for a 90 day storage period. This will allow the short pump to operate frosted for 90 days.

For the long cryopump a dewar size of 17264 gallons (65344 liters) is to be used with a specified net liquid capacity of 12,000 gallons (45420 liters) for a 90 day storage period. This will allow the long pump to operate frosted for 90 days.

3.3.6.3 Vibration And Noise

Vibration Related To Boiling

Since no accurate data is available for vibration levels of boiling liquid nitrogen, a concrete design criteria for vibration related to the boiling of liquid nitrogen was not available. However, a design that keeps bubble generation per unit volume to a minimum should contribute to quiet operation of the cryopump. To minimize the vapor volume formation per unit of liquid volume in the cryopump, a large volume of liquid is desirable. For the same dimensional envelope, the "Annulus" design offers a larger liquid volume than the more common "tube on sheet" design.

Bubble generation within the cryopump annular reservoir is only one of two sources of vibration. The other source of vibration is due to the delivery of the two phase mixture of nitrogen vapor and liquid from the liquid nitrogen supply line. Vapor in the supply line is from heat leaking into the line across the vacuum jacketing around the line, from heat leaking into valves and mechanical connections, and from liquid flashing into vapor across the supply control valve.

Two concepts were initially considered for supplying the two phase mixture to the cryopump:

1. Submergence of a distribution pipe below the reservoir liquid surface with holes along the top and bottom of the pipe to allow vapor to vent from the top holes and liquid to exit from the bottom holes.
2. Placement of the distribution pipe described in 1) above the liquid surface, allowing the vapor to vent from the top holes and liquid to drip down into the bath below it.

In order to assess which concept would produce the least vibration, PSI and Cambridge Acoustical Associates (CAA) agreed to set up a test program to simulate the cryopump operation using bottled nitrogen gas, an elevated container of water, copper tubing, clear plastic tubing (to observe the flow regime in the supply pipe), and a large plastic tank filled with water. Vibration monitoring equipment was supplied by CAA. The nitrogen gas flow and water flow were proportioned to produce the stratified flow regime predicted by two phase flow design calculations. During the course of the testing, it was decided to modify Concept 2) by sawing the distribution pipe lengthwise and pitching it downward to make a chute down which the supply liquid could dribble. The gas of course, escaped out of the top of the tank without ever coming in contact with the bath. It became clear from accelerometer measurements that the chute design was superior to either Concept 1) or 2). The cryopump design therefore incorporates this method of delivery.

Liquid Nitrogen Level Control

The liquid nitrogen level is controlled on the supply side. The tradeoffs of each design are discussed below.

Supply-Side Level Control

In the supply side method, the liquid nitrogen entering the cryopump is controlled by a level control valve on the supply side. The supply valve is extremely small, requiring a Cv of only about .03 to pass the flow required for a long cryopump coated with frost. Its size and location, next to the liquid nitrogen dewar outside the vacuum equipment building, minimizes concern that it will be an objectionable source of vibration. In the event of a rupture of either the cryopump reservoir or the nitrogen supply line, a control valve located at the dewar would prevent a large loss of inventory from the dewar. In order to cool down the cryopump in a reasonable period of time, the control valve is bypassed with a 1/2 inch manual valve in the supply line.

Vent-Side Level Control

Because the nitrogen is now a vapor, flow velocities are higher and may cause noise / vibration. Venting of the vapor might also cause episodes of increased boiling as the pressure drops in the pump. The line could be sized to minimize velocities, however a high velocity will still exist at the control valve. This velocity at the control valve could be minimized by operating with as small a pressure difference as possible between the supply pressure of the storage dewar and the vent pressure which is at atmospheric pressure. A control valve located in the vent line would be unable to prevent a large loss of liquid inventory in the event of a ruptured cryopump reservoir or supply line.

Noise/Vibration Related To Supply And Vent Lines

To reduce heat leak and therefore vapor generation, the supply line diameter was selected to be 1/2 inch N.P.S. The minimization of vapor generation is desirable from a noise and vibration viewpoint. Gas velocities in both the supply and vent lines are extremely low - 1.0 ft/sec and 2.1 ft/sec in each of these lines, respectively. By comparison, air velocities exiting air registers in sound recording studios are recommended to be about 8 ft/sec or less. Since the 80K pump supply and vent lines are vacuum jacketed, no noise is radiated to the vacuum equipment room from them.

Noise/Vibration Related To LN2 Storage Vessel Pressure Controls Controls for Building and Venting Pressure in the LN2 Dewar

Actuation of the dewar controls to maintain pressure in the dewar is not expected to cause any measurable disturbances in the vacuum equipment, since the controls are attached directly to the dewar, which is mounted on its own foundation, and transmission paths to the 80K pump (the regen line and the supply line) are long. Pressure fluctuations in the dewar will cause minor disturbances in the steady state operation of the liquid supply control valve but because the LN2 consumption is so low, the valve can be tuned to react slowly without causing concern that the pump will be drained. Likewise, because the valve is so small, overfilling the pump should not be a concern.

3.3.6.4 Pumping Speed

The 80K cryopump is cylindrical with the inlets at either end. The pumping speed is limited by the cross-sectional area of the inlets. Using a gas temperature of 298 K, the mean velocity for water molecules is calculated to be 529 m/s. The area collision flux at this mean velocity is $148 \text{ m}^3/\text{m}^2\text{-s}$ and with a cross-sectional area of 0.98 m^2 the maximum pumping speed per inlet side is about $144 \text{ m}^3/\text{s}$.

The pumping speed of the 80K pump will not reach the full $167 \text{ m}^3/\text{s}$ because some fraction of the molecules crossing the cross-sectional area will not hit and therefore will not be captured by the cold surface. A Monte Carlo simulation of free molecular flow through a cylinder with a surface sticking coefficient of 1 can be used to determine the capture fraction of the cryopumps.

Capture Fraction: Monte Carlo Simulation

A Monte Carlo simulation was carried out to determine the capture fraction of the 80K cryopump surface for the short pump and the long pump.

The Monte Carlo molecular flow simulator is a computer program that generates a three dimensional model of the reflection and capture of particles in the free molecular flow regime. The molecules are emitted at random directions from a source surface. Reflections are modeled to follow a cosine law distribution. The program has the ability to calculate transmission and capture fractions using a combination of geometric surfaces. Each geometric surface can be defined as a partially/fully capturing, transmitting or reflecting surface.

A Monte Carlo simulation of the capture fraction for the long pump gives a value of 97.4% and a value of 82.8% for the short pump. These simulations provide an estimate of the capture fraction based on a model where the molecular flux at the inlet to the pump is completely random (Maxwellian Distribution). Since the capture fraction of each of the cryopumps is less than 100%, the net pumping speed per inlet side of each cryopump will not be 100% of the maximum pumping speed. In fact any molecules that are not captured in the cryopump enters the beam tube and will be captured on the clean baked surface of the beam tube.

3.3.6.5 Regeneration

Warm-up

Hot gas is supplied by vaporizing liquid nitrogen in the ambient vaporizer, and then raising its temperature in an electric heater to warm the cryopump to 150C.

A bakeout heater blanket is used to heat the vacuum chamber to above 100 deg. C. This will keep moisture driven off the pump from reabsorbing on the chamber walls.

Warm-up Using N₂ Gas

	Heater	Flow rate	LN2 use	Warm-Up Time
Short Pump	12 kW	50 g/s	1800 Liters	8 Hours
Long Pump	25 kW	50-100 g/s	5975 Liters	16.75 Hours

Pumpdown

During warm-up, if the pressure is low enough, pumpout of the water vapor can be done with the turbo pump. The ballast valve on the backing pump needs to be opened to prevent water from condensing in the backing pump. Pumpdown time will vary depending on the amount of water collected on the cryopump. However because of the small volume and relatively large pumping speed of the roughing pump and turbomolecular pump, pumpdown should be very quick. The regeneration time may be dictated by the warm-up time of the vacuum vessel walls to 150°C.

Cooldown

Cooldown From Ambient

	LN2 Consumption
Short 80K pump	265 Liters
Long 80K pump	915 Liters

Cooldown From 423K (150°C)

	LN2 Consumption
Annular Design Short 80K Pump	380 Liters
Annular Design Long 80K Pump	1335 Liters

3.4 Valves

3.4.1 Large Gate Valves (112 and 122 cm)

The large gate valves are supplied by the GNB Corporation of Hayward, California. GNB is experienced both in the manufacture of large gate valves for high vacuum service, and in vacuum vessels.

Both electric and pneumatic actuators are used for the large gate valves. For valves mounted close to chambers, electric actuators are used to minimize possible shock. This includes the vertex section isolation valves at both sites, and the diagonal section isolation valves in Washington. The valves at the Louisiana mid-joints are also electrically actuated to eliminate the need for instrument air systems at those locations. All of these valves have 122 cm clear apertures.

The remainder of the valves are used as cryopump isolation valves (some also serve to isolate the long sections of beam tube). All of these valves have 112 cm clear apertures. All are electrically actuated except the ones at the corner stations, which are pneumatically actuated. These valves are far enough removed from chambers which contain optics so that the closing shock is expected to be attenuated enough to meet the 0.01g peak-to-peak requirement. In summary, there are eight pneumatically actuated valves and twenty-two electrically actuated valves.

Valve features include the following:

- Stainless steel construction
- 122 cm and 112 cm clear aperture
- Internal mechanisms non-lubricated
- Bakeable to 150 C +/- 20 C
- External supports on compliant mounts to further isolate shock (by PSI, and LIGO for the beam tube isolation valves)
- Manual position lock for both open and closed positions
- 1,000 cycle life before service
- Pumpable gate seal (dual o-rings)
- Pumpable bonnet seal (dual o-rings)

Valve shock is produced by the locking action of the valve when it closes. Both the electric and pneumatic valves limit this shock by slowing the speed as the valves approach the fully closed position. This can be more precisely controlled in the electrically actuated valves.

All of the large gate valves are designed for flanged connection in the field (double O-ring grooves are provided in the mating flanges), with the exception of the valves used for beam tube isolation. These valves have weld stubs designed to match the beam tube for automatic welding.

3.4.2 Small Valves

a. Pumpout Ports

1. Roughing, 6" (150 mm) and 10" (254 mm), Manual

These valves are ultra high vacuum gate types constructed of stainless steel with metal bonnet stem seals, Conflat flanges and vacuum-baked Viton gate seals. They are non-lubricated and are rated for 10,000 cycles before maintenance. The leakage rate across the gate seal is less than 1×10^{-10} Torr l/s. The valves can be baked out to 150 C. They are manually actuated and are equipped with limit switches and padlockable devices to prevent inadvertent opening. The valves are manufactured by the Varian.

2. Main Ion Pump, 14" (356 mm), Manual

This valve is an ultra high vacuum gate type constructed of stainless steel with a metal bonnet stem seal, metal flange seals and vacuum-baked Viton gate seal. It is non-lubricated, rated for 10,000 cycles before maintenance and can be baked out to 150 C. The valve is manually actuated (no limit switches) and is equipped with a padlockable device to prevent inadvertent opening. It is manufactured by Varian.

3.5 Vent And Purge Systems

3.5.1 Clean Air Supply

Each site (Washington and Louisiana) will be equipped with one 200 CFM clean air supply system at the corner station and one 50 CFM system at each of the other stations (none at the Louisiana mid-stations). The systems are identical in configuration, and all are self contained, mounted on skids. Each skid is located in the mechanical equipment room to minimize the noise and vibration in the LVEA. The following paragraphs describe the clean air systems:

Compressors

The compressor draws ambient air into the system and through an air intake filter. This air is not taken from the mechanical room, but is piped from the LVEA. An intake silencer is provided in this piping. Each compressor is an oil-free type to preclude the addition of hydrocarbons to the air stream. The following compressor types are used:

1. 200 CFM Systems

The 200 CFM systems use Kobelco Model KNWO-C/L two-stage oil-free rotary screw air compressors. These units are water cooled and self-contained in fully enclosed cabinets. Each compressor system has a variety of controls (including a PLC), instruments and safety devices. The 60 horsepower compressor provides the design flowrate of air at up to 100 psig.

2. 50 CFM Systems

Each 50 CFM system uses five Powerex Model SLP05 scroll compressors in parallel to meet the required capacity. These units are air cooled and are staged by a PLC to come on as needed to maintain the air receiver pressure. Each is self-contained in a fully enclosed cabinet with a variety of controls, instruments and safety devices. Each compressor is 5 horsepower (25 total horsepower) and in combination provides the design flowrate of air at up to 100 psig. Powerex was chosen as the supplier for these units because of their extremely quiet (49 dBA) and low vibration design. A common air-cooled aftercooler will be provided on each skid.

Coalescing Pre-Filter

Prior to entering the desiccant drying towers, any condensate that may be present is removed by passing the air through a coalescing pre-filter. This filter removes all liquid and aerosols to 0.3 μ , allowing only water vapor to pass. A condensate trap removes any liquid from the filter.

Carbon Adsorber

Although an oil free compressor is used, some hydrocarbons that exist in ambient air must be removed. The desiccant dryer will remove most or all hydrocarbons, and the carbon adsorber is used as a further assurance of this requirement.

Desiccant Air Dryer

Process air is directed through one of the twin tower desiccant dryers for removal of water vapor to a dewpoint of -60 C (measured at atmospheric pressure).. The adsorption process is exothermic and a portion of the dried, warm air is used to regenerate the alternate tower. The blowdown air is piped to a silencer located outside of the building. Dryer regeneration is fully automatic, controlled by timers. Air is passed through an additional particulate filter after the desiccant beds.

Air Receiver

Pressurized, clean air is stored in a receiver tank. This is a carbon steel vessel designed, fabricated and stamped in accordance with ASME Section VIII. The receiver for each 200 CFM system is 240 gallons in capacity, while the 50 CFM units are 120 gallon. The air receivers are equipped with a pressure gauge and pressure relief (safety) valve.

After-Filter

The final filter (0.1 μ) removes any bacteria or remaining small particulate prior to use of the air. The filter housing and all piping downstream is stainless steel.

Repressurization back to atmospheric (venting) is accomplished automatically. A portable pressure monitoring and control system is provided for each site. This is required to provide the accuracy needed as the pressure approaches atmospheric (use of the system Parani gauges could result in significant overpressure, or residual vacuum when equipment opening is attempted). The portable system is connected to the RGA roughing port valve with CF flanges. The controller is then set and the purge air compressor started. The portable system will then regulate the position of the back-to-air control valve to control the rate of pressure rise in the vacuum equipment. The portable system includes the following components:

- Capacitance Manometer (Gauge Pressure Transducer)
- PID Controller
- Time Delay Relay
- DC Power Supply
- Check Valve
- Solenoid Valve
- 1 1/2" Flex Hose with CF Flange
- 1 1/2" Vent
- Power and Control Cables

3.5.2 Portable Softwall Cleanrooms

The portable soft-walled cleanrooms (PSC's) are used to isolate sections of the vacuum envelope from the building environment. They will provide a Federal Standard 209 Class 100 environment (while the rooms are "at rest") for the opening of chamber ports.

A total of twelve PSC's will be provided at the Washington site. Three cleanrooms will be located in the corner station, with one each being placed at the end and mid stations. The corner station will have a cleanroom system consisting of two BSC cleanrooms, one HAM cleanroom, and a gowning room. These cleanroom units can be joined to form the desired work space. End and mid stations will each have one BSC cleanroom and a gowning room.

A total of eight PSC's will be provided at the Louisiana site. The corner station will have a cleanroom system consisting of two BSC cleanrooms one HAM cleanroom and a gowning room. The end stations will each have one BSC cleanroom and a gowning room.

A three cleanroom system will be located in the corner station, and one BSC cleanroom (with integral gowning room) will be placed at each end station. The corner cleanroom system will have one BSC cleanroom, one HAM cleanroom, and a gowning room.

3.5.2.1 BSC Cleanrooms

Each BSC cleanroom is 18' - 7" L x 18' - 7" W x 16' H. This cleanroom will have an opening in the ceiling to accommodate the 9' diameter chamber dome, which can be lifted by a crane up through the cleanroom ceiling approximately its entire length without compromising the Class 100 environment. The BSC cleanrooms for the Louisiana mid and end stations will also have integral gowning rooms, since there will be no additional gowning facilities at these locations. For each corner station, one removable filter section is provided for use with a BSC cleanroom when it is used away from a BSC.

3.5.2.2 HAM Cleanrooms

Each HAM cleanroom is 16' - 9" L x 11' - 11" W x 12' H. It is similar in design to the BSC cleanrooms, but without the dome accommodation or integral gowning rooms.

3.5.2.3 Common Cleanroom Features

A Class 100 environment (at rest) will be achieved in all cleanrooms by utilizing blowers with pre-filters ducted to a HEPA filtering system. The filters will have dampers for initial flow balancing. The blowers will have variable speed controllers to reduce the power consumption during periods of inactivity, or will be single speed ducted so as to allow half to be turned off during such times..

All cleanroom frames will be constructed with painted tubular steel. Trusses for overhead support will be used so that the cleanrooms can be lifted and moved into place by the building overhead crane. Heavy duty lockable casters will be utilized to allow location adjustment of the cleanrooms. Cleanrooms of like size will have the capability to mate to each other in order to form larger working areas. 40 mil clear vinyl curtain will be hung on all cleanrooms to an appropriate height above the floor to provide proper pressurization and air flow.

The cleanrooms will be equipped with a removable six foot square window in at least three sides. The vinyl sections provided for this window will seal around the tube or nozzle entering the cleanroom. An additional two inch diameter hole will be provided in this window to be used for laser alignment during equipment installation. The bottom of the six foot window will have a velcro-sealed slit directly below it, extending to the bottom of the wall to allow lowering the cleanroom into place over the tube.

3.5.2.4 Electrical

The cleanrooms will be fed by 480V, 3-phase power. Each cleanroom has a power panel with overcurrent protection. The BSC rooms without integral gowning rooms are provided with receptacles for connection of a gowning room.

Sealed overhead lighting will be provided in all cleanrooms. Lighting and blower controls for each cleanroom will be located conveniently on the cleanroom wall. A single, centrally located electrical service box will be provided in each cleanroom.

3.5.2.5 Cleanroom Accessories

The following cleanroom accessories are provided:

- Airborne Particle Counter with 0.3 micron sensitivity (one per site).
- Magnehelic Gauge for measuring internal static pressure and filter pressure drop (two per cleanroom).
- Stainless Steel Gowning Bench (one per site).
- Open Wire Garment Storage Rack (one per station, except Louisiana mid-stations).

3.6 Bakeout/Heating Subsystem

The scope of the bakeout system is one bakeout system, which will be used at the Hanford, WA. site and then transported to Livingston, LA. PSI has determined that large scale, conventional bakeout blankets or "mantels" best meet the bakeout requirements and specification criteria of the LIGO project and included this approach in our design (one system capable of baking out WA or LA sites).

The heating blanket system will be designed to heat the vacuum system from ambient to +150C with a maximum variation of -20C to +20C. Temperature ramping rate control will be provided.

The blanket system is estimated to require 150 to 180 kW at 480/277 VAC, 3-phase power at maximum heat-up of a corner station.(This represents the largest load for any of the bakeout configurations).

The following paragraphs describe the general configuration of the mantel type bakeout system:

A method of heating the vacuum chambers and specific components for bakeout and conditioning is provided in the form of custom manufactured blanket system (approx. 640 blanket circuits). Each circuit consists of insulated heater blankets (mantels), designed to fit tightly to the component being heated. The blankets contain flexible heating elements, arranged in multiple zones, captured within a durable, insulating blanket construction. Each blanket has two (2) thermocouple sensors for temperature control, alarm and shutdown.

Control and power distribution systems for the blankets are mounted on portable carts that may be moved to the various locations when required for use. The carts will be equipped with power cables to plug into facility utility outlets. Blanket power harnesses and control thermocouples will plug into dedicated connectors located on the cart. Power is applied to the blankets in accordance with a pre-determined ramp program. A programmable logic controller (PLC) with thermocouple data acquisition system will be used to control the temperature profile, uniformity and interlocking functions. Each blanket will be controlled using time proportioning on-off controller (electronic). A CRT based operator interface will be provided on each cart. When more than a single cart is required to bakeout a single isolatable section, they will communicate, as a "Configured System", with each other over a plug-in Data Highway Plus network. A master temperature setpoint will control all carts. The carts can also be used in a stand alone mode.

The quantity of blankets to be provided is based on the minimum number of blankets to bakeout any isolatable LIGO vacuum zone.

The largest isolatable zone for the Washington site is defined as:

Vertex and Beam Manifold Sections composed of:

- Six (6) HAM chambers
- Three (3) BSC chambers
- Two (2) Mode Cleaner Tubes
- One (1) Beam Tube
- One (1) 80 K Cryo Pump (long)
- Four (4) large gate valves
- Six (6) large bellows sections

In addition, blankets are included for the components at the Washington site:

- One (1) Short 80 K Cryo pump
- Six (6) small gate valve (6-14 inch)
- Six (6) 250 deg. C gauge pair bakeout blankets
- Four (4) main ion pumps

The Vertex section and Beam Manifold will not be baked simultaneously. The Vertex section, including all HAM chambers, BSC chambers and Mode Cleaner Tubes will be baked first. The Beam Line, 80 K Cryo. pump and BSC chamber will then be baked, using the portable bakeout carts used in the Vertex section.

The Washington site bakeout system will be designed to allow reconfiguration for use at the Louisiana site.

3.6.1 Bakeout Blankets

The bakeout blankets will be supplied by HTD Heat Trace, Inc. in accordance with PSI specification V049-2-009, Rev. 3. Characteristics of the blankets are as follows:

1. Heating rate of the vessels to $150^{\circ}\text{C} \pm 20^{\circ}\text{C}$ at a rate of 1.8°C/hr .
2. Durable construction; all materials are rated for a maximum temperature exposure of 450°C .
3. Siliconized glass cloth inner jacket.
4. Two (2) inch minimum insulation KAO WOOL ceramic fiber.
5. Two (2) type "J" thermocouples, cables and plugs (per blanket).
6. One (1) 277 Volt heater circuit, cable and plug (per blanket).
7. One (1) 3" x 4" blanket removable patch for TC's installation.
8. Low emissivity aluminized glass cloth outer jacket.
9. Non-removable tag.

These blankets will be installed on any isolatable section according to a bakeout blanket configuration. This configuration shows the vacuum system, the blankets layout and each blanket tag number. Oversized velcro and fiberglass thermal flaps are used to eliminate exposed air gaps between blankets.

Nylon straps and thermal strap loops are used to ensure tight fit against the surface being heated.

All blankets are connected to and controlled by portable bakeout carts. Refer to Section 3.6.2.

3.6.2 Bakeout Control System

Each Bakeout Cart has the following heater blankets available:

1. (92) Chamber Blankets
2. (16) Aux. Blankets
3. (4) Gauge Blankets

The 76 Chamber blankets on each Cart can be networked together via the PLC Data Highway Plus network to form a "Configured System". The Configured System will communicate and control all chamber blankets to ramp at the same rate, and stay within the required ± 20 Deg C temperature differential. A master cart will be selected and this cart will control the Mode / Sequence for all the other carts on the Configured System.

The 16 Aux. Blankets and 4 Gauge Blankets on each cart will work independently.

See V049-2-086 for details on the Control Functionality.

The LIGO Bakeout Cart System consists of up to (6) six Allen-Bradley PLC 5/30 controllers networked via Data Highway Plus cable spanning over any isolatable section of the Vacuum Vessel System. Each of the (6) six carts contains a PC operator interface which is connected directly to the individual cart PLC. An individual Cart Control System layout is shown on the following drawings :

1. PLC / PC / Data Acquisition Configuration V049-3-014
2. Cart Assembly V049-3-013 (7 Sheets)
3. Electrical Schematic, Control System V049-3-011 (9 Sheets)
4. Electrical Schematic, Heater Power V049-3-012 (2 Sheets)
5. Fabrication of Bakeout Control Sys Cart V049-2-068

Each Bakeout Cart will contain the following control equipment :

1. Allen-Bradley PLC 5/30 Programmable Logic Controller (PLC) with (8) 16 point 120 VAC output modules and (1) 16 point VAC input module. See V049-2-076 for more details on hardware.
2. IO-Tech 192 point Thermocouple Data Acquisition System that communicates to the PLC 5/30 via a RS-232 communication module (1771-DMC). See V049-2-050 and V049-2-051 for more details on hardware. See V049-2-053 for details on Data Acquisition Functionality.
3. Gateway-2000 Pentium 120 PC with 16 MEG Ram, 810 MB HD, 3 1/2" 1.44 MB DD, 17" SVGA Monitor running Windows NT and Intellution DMACS operator Interface Software. See V049-2-049 and V049-2-057 for more details on hardware. See V049-2-058 for operator interface software details.

3.7 **Monitor And Control System:**

PSI is providing self contained monitoring and control systems for Turbo, Roughing, Auxiliary Turbo, and Bakeout carts. However, additional remote system status monitoring capabilities are incorporated in the design (except for the bakeout cart). LIGO will implement the interconnecting wiring if remote monitoring is desired.

All other systems and instruments will be monitored and controlled by LIGO's control system.

The following sections provide all necessary information which allows LIGO to program the control system and provide system safety.

3.7.1 Vacuum Gauging

The smart gauges were selected for their ease of integration into the type of control system selected. They are all self contained, with removable electronics for baking. These units are connected to 2 3/4" CF flanges. No standalone controllers are required.

The following Vacuum Gauging will be supplied & located as shown on the P&ID's.

- **Pirani Gauge/Transducer**

Quantity: 39 (25 for WA, 14 for LA)
Manufacturer: MKS
Model: 109070023 BH₃
Range : 1000 to 1×10^{-3} Torr
Output: 0.3 - 5.6 VDC non-linear
Input: 24 VDC
Temperature: 250⁰C maximum (300⁰C intermittent) with electronics removed.

- **Cold Cathode Gauge Transducer**

Quantity: 39 (25 for WA, 14 for LA)
Manufacturer: MKS
Model: 93-1289
Range: 1×10^{-2} to 3×10^{-11} torr
Output: 1.5 - 8.5 VDC linear
Input: 24 VDC
Temperature: 250⁰C maximum (300⁰C intermittent) with electronics & magnet removed.

NOTE: Recommended maximum pressure for energizing the cold cathode is 6×10^{-3} torr.

3.7.2 Other Instruments

80K Pumps will have the following instrumentation:

- **Pressure Transmitters (Cryopumps)**

Quantity: 12
Manufacturer: Rosemount
Model: 2088G1A22A1B4Q4
Range: 0-30 PSIG
Output: 4-20 mA_{dc}
Calibration: 0-25 PSIG

- **LN₂ Level Transmitters (Cryopumps)**

Quantity: 12
Manufacturer: Rosemount
Model: 1151DP4E52B4Q4
Range: 0-150 inch H₂O
Output: 4-20 mA_{dc}
Calibration: 0-41 inch H₂O

- **LN₂ Level Transmitter (LN₂ Tank)**

Quantity: 12
Manufacturer: Rosemount
Model: 2024D3A12A2S1B4Q4
Range: 0-1000 inch H₂O
Output: 4-20 mA_{dc}
Calibration: 0-379 inch H₂O For Mid & End Stations
0-153 inch H₂O For Corner Stations

- **Flow Meter**

Quantity: 12
Manufacturer: ERDCO
Model: 3211-06-TI
Range: 0-12000 SCFH
Calibration: 0-12000 SCFH

- **Thermocouple Assembly (Regen Line)**

Quantity: 24
Manufacturer: PSI
Range: Type "K" TC
Output: mV

3.7.2.5 Back To Atmosphere Cart

A portable cart will control the repressurization process. The system consists of two hand valves, a capacitance manometer, and the flex hoses and fittings necessary to connect to the back to air port and the RGA port on the isolatable volume, and the CL100 air header. The system is designed to utilize a capacitance manometer for accuracy when the pressure nears atmosphere. Two separate hand valves are provided. V1 is a small angle valve that is used to bring the isolated volume back to approximately 1/2 atmosphere. V2 is a variable orifice hand valve for pressures between 1/2 atm and 1 atm. V1 is sized to handle either 100 cfm or 50 CFM depending on whether it is located in a corner station or mid/end station. V2 provides the ability to vary the flow during the last critical phase of the backfill. Again the valve would have a maximum capacity of either 100 or 50 cfm depending on location.

3.7.3 Cabinets

When reviewing this section, reference can be made to the following drawings:

V049-3-125	3 Shts	Vacuum Carts Interface Plan Corner Station
V049-3-206 V049-3-207	2 Shts	Vacuum Carts Interface Plan Left Mid Station PNL-200 Wiring Diagram Left Mid Station
V049-3-306 V049-3-307	2 Shts	Vacuum Carts Interface Plan Right Mid Station PNL-300 Wiring Diagram Right Mid Station
V049-3-406 V049-3-407	2 Shts	Vacuum Carts Interface Plan Left End Station PNL-400 Wiring Diagram Left End Station
V049-3-506 V049-3-507	2 Shts	Vacuum Carts Interface Plan Right End Station PNL-500 Wiring Diagram Right End Station

Reference PSI Drawings V049-3-004, V049-3-121, V049-3-122, V049-3-207, V049-3-307, V049-3-407 and V049-3-507, Main Ion Pump Panels Assembly and Wiring Diagrams.

Each 2500 l/s ion pump is supplied with a vacuum indicating controller. These controllers are installed in panels which are located at each mechanical room. Ion pump control panels are provided by PSI. Each panel has terminals and a dedicated receptacle for each controller.

Reference PSI Drawings V049-3-125, V049-3-206, V049-3-306, V049-3-406 and V049-3-5-6, Vacuum Carts Interface Plan.

The backing pump cart for the main roughing cart and the backing pump cart of the turbomolecular pump cart located at the mechanical rooms require an interface cable.

At each site there will be instrument racks to house the following equipment:

- Ion Pump Controllers
- Input Terminal Blocks for Control Power
- 24 vdc Power Supplies for Instrument Power
- Circuit Protection Devices as required
- Power Outlet Strips
- Power Filter units
- Interior Maintenance Lights

3.7.4 Interlocks

Refer to PSI Specification V049-2-092.

3.7.4.1 Main Roughing Pump Skids (Self Contained Control System)

- The roots pumps with its backing pumps and backing valve.
- The roots pumps and the roots pump backing valve with the vacuum pressure feedback signal from the chamber being pumped.
- The roots backing valve with the backing pump.
- The roots fore valve with power failure.
- The backing pumps with cooling flow.
- The backing pumps with N2 seal gas flow.
- The backing pumps with over load relays.
- The roots pumps with over load relays.
- Refer to the manufacture literature for more details

3.7.4.2 Main Turbo Pump Skids (Self Contained Control System)

- The turbo pump with its backing pump, backing valve & inlet and outlet vacuum pressures.
- The turbo pump & turbo pump backing valve with the vacuum pressure feedback signal from the chamber being pumped.
- The turbo backing valve with the fore pump.
- The turbo backing valve with all power failures.
- The backing pump with cooling flow.
- The backing pumps with N2 seal gas flow.
- The backing pump with over load relays.
- The turbo pump with controller failure.
- Refer to the manufacture literature for more details.

3.7.4.3 Auxiliary Turbo Pump Skids (Self Contained Control System)

- The turbo pump with its backing pump, backing valve & inlet and outlet vacuum pressures.
- The turbo pump & turbo pump backing valve with the vacuum pressure feedback signal from the chamber being pumped.
- The turbo backing valve with the backing pump.
- The turbo backing valve with all power failures.
- The backing pump with cooling flow.
- The backing pump with instrument air pressure.
- The backing pump with over load relays.
- The turbo pump with controller failure.

3.7.4.4 The Main Ion Pumps

- The ion pumps with its vacuum pressure interlock from the PLC controller.
- The ion pump with controller failure. (One per HV module).

3.7.4.5 The Annulus Ion Pumps

- The ion pumps with its vacuum pressure interlock from the PLC controller.
- The ion pump with controller failure.

3.7.5 Required Controls By Others

3.7.5.1 A central PLC control system (provided by LIGO) will provide commands that operate the main gate valves, the cryopumps & the main ion pumps on each section. This PLC system will be programmed by LIGO from cause/effect diagrams and software alarm listings provided by PSI. See V049-2-092 for details on control permissive/interlocks (cause/effect) and software alarming.

3.7.5.2 Instrument air requirements will be supplied by the instrument air systems for the HVAC equipment in the mechanical equipment rooms (by others).



4.0

SHOCK, VIBRATION, AND ACOUSTICS

The LIGO specification places special operational constraints on the functioning of a number of devices which make up the interferometer vacuum system. Consideration has been given to these devices as sources of noise, vibration, and shock and their effect on the sensitivity and alignment of the interferometer. Process Systems International, Inc. has engaged the services of Cambridge Acoustical Associates, Inc. (CAA) to put in place a plan to reduce the risks associated with these issues. The plan consists of the following parts:

- a. Potential vacuum system equipment is evaluated with respect to vendors' stated vibration, noise, and shock performance and the inherent equipment design features that impact these characteristics. Equipment generating the lowest possible noise and vibration commensurate with performance is recommended.
- b. Tests are made on selected operating equipment in a qualified test facility to verify vendor claims and to supplement vendor data with detailed measurements to cover the full range of the LIGO specifications. Because the specified vibration levels are extremely low, low noise instrumentation and specialized equipment mountings are used to enhance the capability to obtain measurements over the full frequency range specified.
- c. Based on the extent of mitigation required both in terms of amplitude reduction and frequency range, vibration and noise treatments are designed. Constraints imposed by the LIGO facility are incorporated into the treatment design.
- d. Transmission of shock, vibration, and acoustics from the sources to the vacuum chambers and to the laboratory floor within one meter of any vacuum chamber are analyzed mathematically. Estimated levels with first order treatment in place are compared with LIGO specifications. Regions where compliance with specification is not achievable are identified for further review and assessment.

A detailed description of this plan and the results to date may be found in Attachment 4 of this report entitled "Measurement and Analysis of LIGO Vacuum System Shock, Vibration and Acoustics."

4.1 Shock

The concern regarding shock is the "irreversible" misalignment of the optics within the interferometer. Sources of shock in the vacuum system are the gate valves. The specification limit for actuation of these devices is 0.01 g peak-to-peak acceleration measured within 1 meter of any chamber. Both pneumatic and electrical actuators are used with the gate valves. The electrical actuators feature low shock mechanisms and are designed to meet the shock requirements. The pneumatically actuated gate valves are located a sufficient distance from any chamber to impact the shock requirement.

4.2 Vibration

Excessive vibration from pumping equipment results in a loss of interferometer sensitivity. Vibration has been highlighted as a concern during intermediate pumpdown (from 1 torr to 10^{-6} torr), and during final pumpdown and normal operation (below 10^{-6} torr). Low vibration (vibration response which satisfies specification requirements) during intermediate pumpdown has been identified by the LIGO project office as a design goal. Because intermediate pumpdown is of limited duration, failure to meet the specification is not crucial to the LIGO mission. However, the main turbomolecular pumps have not been exempted from the vibration specification. Of paramount concern is vibration during final pumpdown and normal operation. Failure to meet the specification here would result in LIGO mission impairment, and constitute a large technical risk. The pumping devices which operate during this phase of operation are the 80 K pumps and the ion pumps. PSI's technical approach to reduce vibration in these devices is described below.

4.3 Acoustics

Excessive noise radiated from pumping equipment has the potential to disrupt interferometer observations by inducing vibration. As in the case of vibration, the period of most concern is final pumpdown and normal operation. Equipment operating during intermediate pumpdown has not been exempted from meeting the noise criterion, however. PSI's technical approach to acoustic noise is also described below.

4.4

Technical Approach to Shock, Vibration, and Acoustics/Risk

Details of the technical approach which addresses the above issues are described by Cambridge Acoustical Associates, Inc. in the attachment previously referenced. A summary of treatments to mitigate risk to the interferometer in PSI's design is as follows:

- a. The main roughing pump system is separated onto two skids. The roots blower, attached to the interferometer, is on one skid. A bellows will separate the roots blower from the interferometer to reduce the possibility of shock loading it. The first stage blower and backing pumps will be skidded separately and placed in the Mechanical Equipment Room. Placing the first stage blower in the Mechanical Equipment Room reduces plant personnel exposure to excessive noise.
- b. Each of the main turbomolecular pumps is separated from its backing pump. The turbopump is placed on its own cart and separated from the interferometer by a soft bellows. The turbopump/cart is anchored to the floor to prevent the bellows from compressing axially due to the external pressure. High frequency isolators in the form of rubber bushings and washers isolate the turbopump from the cart.

The backing pump, which is a much greater source of vibration than the turbopump, is placed on its own cart and located in the Mechanical Equipment Room. The backing pump cart has its own vibration isolators and noise enclosure.

- c. The source of vibration with the ion pumps are the power supplies. For the large ion pumps the power supplies are located in the Mechanical Equipment Room. Vibration isolators will be used if needed. The small ion pumps' power supplies are located in the Vacuum Equipment Room. They rest on vibration isolators.
- d. The 80K pumps will produce vibrations due to the formation and collapse of bubbles in the liquid nitrogen. The generation of large bubbles via the inlet pipe has been reduced by bringing the stratified flow from the inlet pipe above the liquid reservoir. The incoming liquid flows gently down a chute into the reservoir while the gas escapes without bubbling through the liquid. The bubbles generated from the boiling liquid in the reservoir are smaller and generate higher frequencies. Vibration transmission into the interferometer resulting from this action is reduced by low frequency isolators.

An additional source of vibration from the 80 K pump operation is due to vibration in the supply and return lines. Flex lines are used to attenuate the vibration.

- e. The large gate valves are compliantly supported from below to isolate them from the facility floor.
- f. The vent and purge system will be skidded and placed inside the Mechanical Equipment Room. The skid is mounted on vibration isolators. The discharge and suction of the system in the corner station have mufflers or sound attenuators. The mid and end stations systems are not operated during normal operation.

4.5 **Source Measurements and Transmission Analysis**

Source measurements have been made on all of the scheduled components and results were presented at the Prototype Vessel Data Review Meeting. A final report which will include these data and the transmission analysis will be provided in a separate document.

ATTACHMENTS

Attachment 1

Calculations

Structural Design Criteria

BSC's - Structural

General - Structural

HAM - Structural

Attachment 2

Calculations

80K Cryopump - Structural

Adapters and Spools - Structural

Attachment 3

Calculations

Adapters and Spools - Structural

Attachment 4

Calculations

Vacuum and Process Calculations

Safety and Reliability Analysis

Attachment 5

Specifications/Miscellaneous

Shock, Vibrations and Acoustics

Design Goals/Requirements

Specifications