

REV.	DATE	DCN #	DRAWING TREE #
v1	24 Mar. 2011	E1100015	E1100016

NOTES:
 4. VENDOR REFERENCES ARE PROVIDED AS EXAMPLES OF PARTS MEETING ALL REQUIRED SPECIFICATIONS. EQUIVALENTS ARE ALWAYS ACCEPTABLE UNLESS OTHERWISE SPECIFIED.
 5. REFER TO LIGO E0900357 FOR ASSEMBLY AND LOADING PROCEDURE.

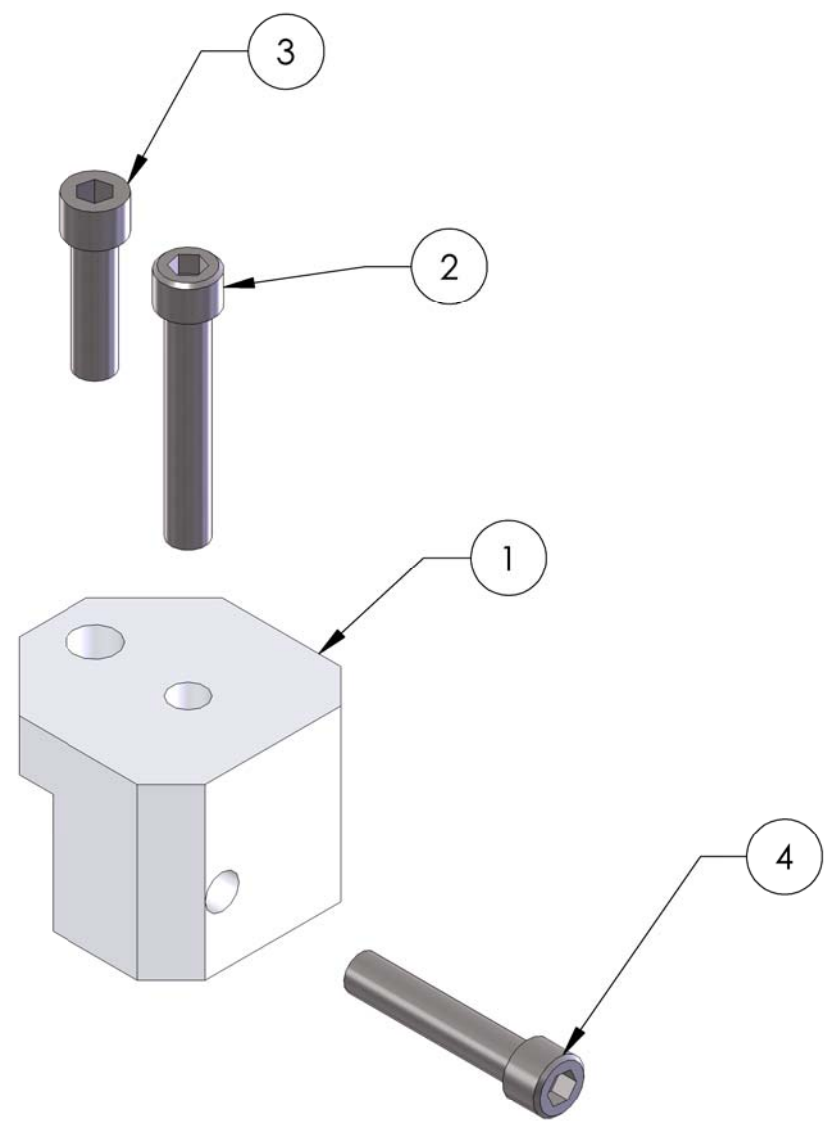

4	HOLOKROME_72142	SCREW 1/2-20 X 2.5 LG SHCS	Alloy Steel	1
3	HOLOKROME_73136	SCREW, 1/2-20 X 1.75 LG, SHCS	Alloy Steel	1
2	HOLOKROME_72242	SCREW 1/2-13 X 3" LG SHCS	Alloy Steel	1
1	D020271	STRAIGHT CLAMP	AISI 1018 Steel, Cold Rolled	1
ITEM NO.	PART NUMBER	DESCRIPTION	MATERIAL	REQ

NOTES AND TOLERANCES: (UNLESS OTHERWISE SPECIFIED)				LIGO CALIFORNIA INSTITUTE OF TECHNOLOGY MASSACHUSETTS INSTITUTE OF TECHNOLOGY		PART NAME	
DIMENSIONS ARE IN INCHES		1. INTERPRET DRAWING PER ASME Y14.5-1994.		ADVANCED LIGO		SUB-SYSTEM SEI	
TOLERANCES: .XX ± N/A .XXX ± N/A		2. REMOVE ALL SHARP EDGES, .03 x 45°.		DESIGNER O.SPJELD 8 June 2004		SIZE DWG. NO.	
ANGULAR ± N/A*		3. DO NOT SCALE FROM DRAWING.		DRAFTER M.HILLARD 24 Mar. 2011		B D1100529	
MATERIAL SEE BOM		FINISH N/A μinch		CHECKER K.MASON 8 June 2004		REV. v1	
		NEXT ASSY D040002, D040001		APPROVAL K.MASON 24 Mar. 2011		SCALE: 1:2 PROJECTION: SHEET 1 OF 1	

D1100529, PART PDM REV: X-000, DRAWING PDM REV: X-000