

NOTES CONTINUED:
 5. SCRIBE, ENGRAVE (A VIBRATORY TOOL MAY BE USED), LASER MARK OR MECHANICALLY STAMP (NO INKS OR DYES) DRAWING PART NUMBER, REVISION (AND VARIANT OR "TYPE" IF APPLICABLE) ON NOTED SURFACE OF PART FOLLOWED ON THE NEXT LINE WITH A THREE DIGIT SERIAL NUMBER. SERIAL NUMBERS START AT 001 FOR THE FIRST ARTICLE AND PROCEED CONSECUTIVELY. USE MINIMUM 0.12" HIGH CHARACTERS, UNLESS THE SIZE OF THE PART DICTATES SMALLER CHARACTERS. EXAMPLE: DXXXXXX-VY, TYPE-XX, S/N XXX
 6. APPROXIMATE WEIGHT = .10 LB [47 G].
 7. MACHINE ALL SURFACES TO REMOVE OXIDES AND MILL FINISH. USE OF ABRASIVE REMOVAL TECHNIQUES IS NOT ALLOWED.
 8. ALL PARTS SHALL BE MANUFACTURED IN ACCORDANCE WITH LIGO SPECIFICATION E0900364.
 9. NO REPAIRS SHALL BE MADE UNLESS APPROVED IN ADVANCE, AND IN WRITING, BY LIGO LABORATORY. IN GENERAL WELD REPAIRS AND PRESS FIT INSERT REPAIRS ARE NEVER ACCEPTABLE; THE MATERIAL SHOULD BE MADE WITH VIRGIN MATERIAL. SPECIAL CIRCUMSTANCES CAN BE REVIEWED IF / WHEN BROUGHT TO THE ATTENTION OF LIGO CONTRACTING OFFICER'S REPRESENTATIVE (COTR) THROUGH A MATERIAL REVIEW BOARD (MRB) PROCESS, REFER TO LIGO-E0900364.

REV.	DATE	DCN #	DRAWING TREE #
v1	25 MAR 2011	E1000384-v1	-
-	-	-	-
-	-	-	-

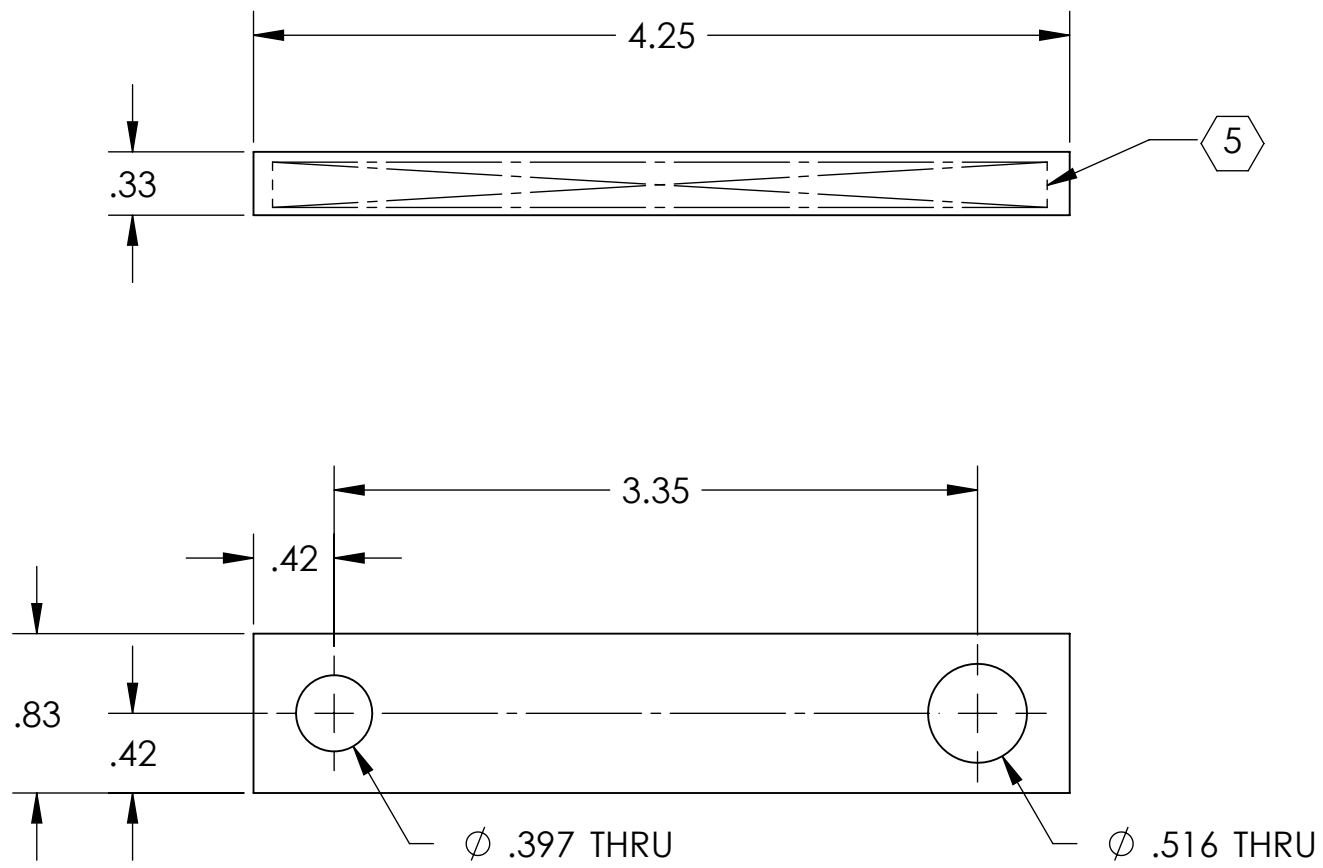
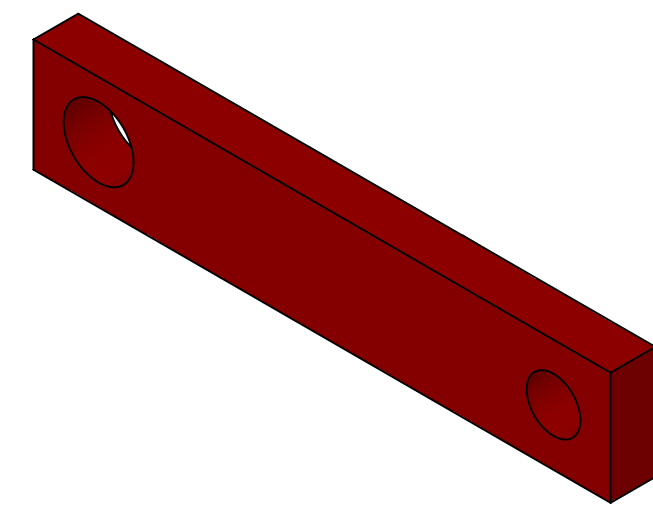

D1100499 TMS Horizontal Restraint Link, PART PDM REV: X-013, DRAWING PDM REV: X-002

NOTES AND TOLERANCES: (UNLESS OTHERWISE SPECIFIED)				LIGO CALIFORNIA INSTITUTE OF TECHNOLOGY MASSACHUSETTS INSTITUTE OF TECHNOLOGY		PART NAME			
DIMENSIONS ARE IN INCHES		1. INTERPRET DRAWING PER ASME Y14.5-1994. 2. REMOVE ALL SHARP EDGES, R.02 MIN. 3. DO NOT SCALE FROM DRAWING. 4. ALL MACHINING FLUIDS MUST BE FULLY SYNTHETIC, FULLY WATER SOLUBLE AND FREE OF SULFUR, SILICONE, AND CHLORINE.		SYSTEM LIGO		SUB-SYSTEM AOS		TMS HORIZONTAL RESTRAINT LINK	
TOLERANCES: .XX ± .01 .XXX ± .005		MATERIAL 304 SSSL		FINISH 63 μinch Ra		NEXT ASSY D1001781		DESIGNER C. CONLEY 16 MAR 2011	
ANGULAR ± 1.0°						DRAFTER C. CONLEY 21 MAR 2011		SIZE DWG. NO. B D1100499	
						CHECKER		REV. v1	
						APPROVAL		SCALE: NONE PROJECTION: SHEET 1 OF 1	