

D1100402 TMS TOOLING Telescope Alignment Support Spacer, PART PDM REV: X-005, DRAWING PDM REV: X-005

8 7 6 5 4 3 2 1

- NOTES CONTINUED:**
- 5. SCRIBE, ENGRAVE, OR MECHANICALLY STAMP (NO INKS OR DYES) DRAWING PART NUMBER, REVISION (AND VARIANT OR "TYPE" IF APPLICABLE) ON NOTED SURFACE OF PART FOLLOWED ON THE NEXT LINE WITH A THREE DIGIT SERIAL NUMBER. SERIAL NUMBERS START AT 001 FOR THE FIRST ARTICLE AND PROCEED CONSECUTIVELY. USE MINIMUM 0.12" HIGH CHARACTERS, UNLESS THE SIZE OF THE PART DICTATES SMALLER CHARACTERS. A VIBRATORY TOOL MAY BE USED.
EXAMPLE: DXXXXXX-VY, TYPE-XX, S/N XXX
 - 6. APPROXIMATE WEIGHT = X.XXX LB.
 - 7. MACHINE ALL SURFACES TO REMOVE OXIDES AND MILL FINISH. USE OF ABRASIVE REMOVAL TECHNIQUES IS NOT ALLOWED.
 - 8. ALL PARTS SHALL BE MANUFACTURED IN ACCORDANCE WITH LIGO SPECIFICATION E0900364.
 - 9. ALL HELI-COIL HOLES TO BE PREPARED ACCORDING TO EMHART HELI-COIL PRODUCT CATALOG, HC2000, REV 4
 - 10. ALL HELI-COIL INSERTS TO BE INSTALLED BY LIGO PERSONNEL. AFTER DELIVERY OF FINISHED PARTS, USE NITRONIC 60 THREADED INSERTS.
 - 11. ALL MATERIAL IS TO BE VIRGIN MATERIAL (i.e. NOT WELD REPAIRS OR PLUGS UNLESS APPROVED IN ADVANCE IN WRITING BY LIGO, REFER TO LIGO-E0900364.
 - 12. NO REPAIRS SHALL BE MADE UNLESS APPROVED IN ADVANCE, AND IN WRITING, BY LIGO LABORATORY. IN GENERAL WELD REPAIRS AND PRESS FIT INSERT REPAIRS ARE NEVER ACCEPTABLE. THE MATERIAL SHOULD BE MADE WITH VIRGIN MATERIAL. SPECIAL CIRCUMSTANCES CAN BE REVIEWED IF / WHEN BROUGHT TO THE ATTENTION OF LIGO CONTRACTING OFFICER'S REPRESENTATIVE (COTR) THROUGH A MATERIAL REVIEW BOARD (MRB) PROCESS, REFER TO LIGO-E0900364.

REV.	DATE	DCN #	DRAWING TREE #
v1	01 JUN 2011	E1100352	-
-	-	-	-
-	-	-	-

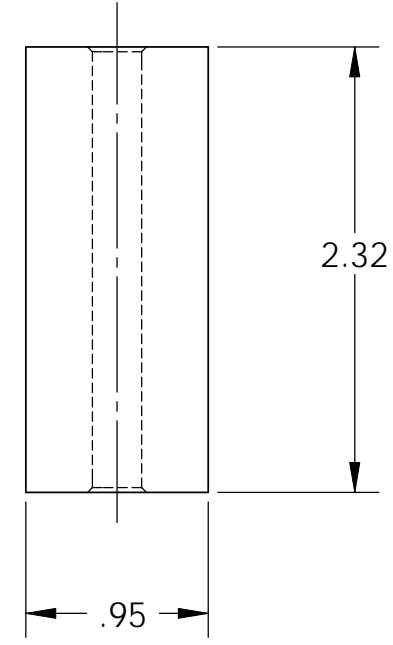
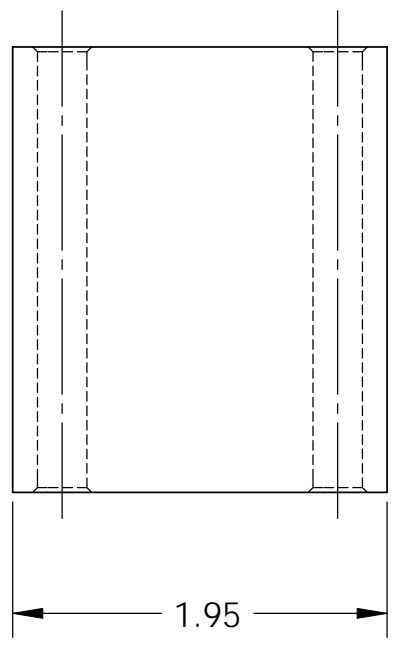
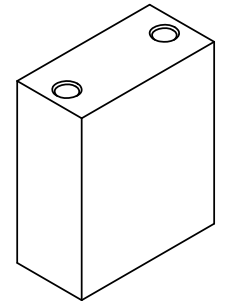
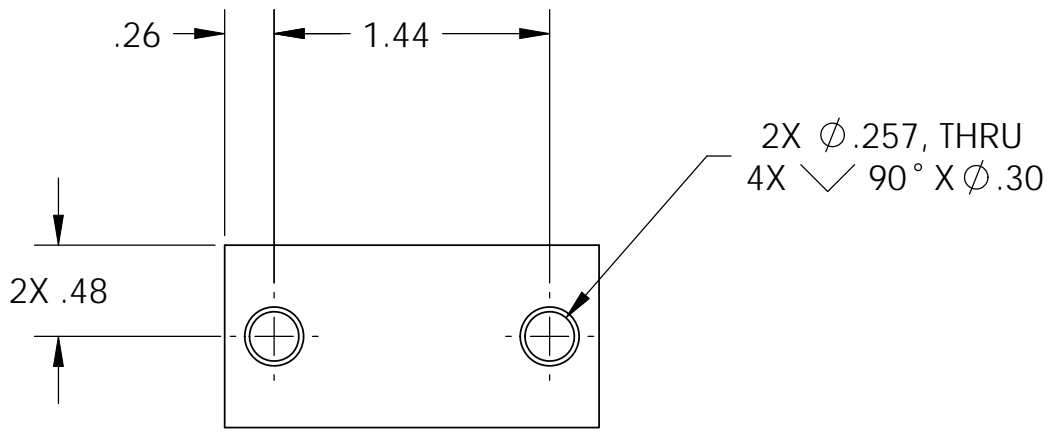

C
B
A

D
C
B
A

NOTES AND TOLERANCES: (UNLESS OTHERWISE SPECIFIED)				LIGO CALIFORNIA INSTITUTE OF TECHNOLOGY MASSACHUSETTS INSTITUTE OF TECHNOLOGY		PART NAME TMS TOOLING TELESCOPE ALIGNMENT SUPPORT SPACER							
DIMENSIONS ARE IN INCHES		1. INTERPRET DRAWING PER ASME Y14.5-1994. 2. REMOVE ALL SHARP EDGES, R.02 MIN. 3. DO NOT SCALE FROM DRAWING. 4. ALL MACHINING FLUIDS MUST BE FULLY SYNTHETIC, FULLY WATER SOLUBLE AND FREE OF SULFUR, SILICONE, AND CHLORINE.		SYSTEM	ADVANCED LIGO	SUB-SYSTEM	AOS	DESIGNER	C. CONLEY	01 MAR 2011	SIZE	DWG. NO.	REV.
TOLERANCES: .XX ± .01 .XXX ± .005		MATERIAL	6061-T6 Al	FINISH	63 μinch	NEXT ASSY	D1100613	DRAFTER	M. MILLER	03/03/2011	B	D1100402	v1
ANGULAR ± 1.0°						CHECKER		APPROVAL		SCALE: 1:1	PROJECTION:	SHEET 1 OF 1	

8 7 6 5 4 3 2 1