

---

# BEAM TUBE BAKEOUT DESIGN REQUIREMENTS REVIEW

*DECEMBER 11, 1996*



# SCOPE OF BAKEOUT DRR

---

- Design requirements for the bakeout equipment
  - ›› heating power and controls, thermal insulation, vacuum pumping, instrumentation, data acquisition and logging
- Interfaces
- Conceptual Design
- Implementation

# LIGO REQUIREMENTS

---

- LIGO Science Requirements Document

- ›› sets the goal for residual gas pressure “....at a level or below an equivalent strain noise of  $2 \times 10^{-25} \text{ Hz}^{-1/2}$ ”

# ASSUMPTIONS AND DEPENDENCIES

---

- The beam tube will be baked out in increments of 2 km modules.
- Adequate AC power (13.8 kV, 1300 kVA) will be available along the beam tubes.
- Safe access to beam tube enclosures during installation and bake (if needed) will be allowed.
- The beam tube will have been accepted from the beam tube fabrication and installation contractor and will meet its performance requirements (E950020).
- The beam tube is left under rough vacuum up to the time of the bakeout.

# ASSUMPTIONS AND DEPENDENCIES

## (con't)

---

- Leaks larger than the LIGO specification which are present after the bakeout will be identified and localized, but repair/recovery procedures are not within the scope of this document.
- Insulation and thermal sensors will be left in place after each beam tube module is baked.

# DESIGN REQUIREMENTS

---

- COMPONENTS TO BE BAKED

- ›› All vacuum surfaces of the bake volume (i.e., tube wall material, expansion joints, pump ports, pump port hardware, 122cm gate valves, etc.)

- PARTIAL GAS PRESSURES DURING THE BAKEOUT

- ›› Control by suitable choice of pumping speeds and control of temperature rate-of-rise

- ›› Maintain the RGA in its linear range

- ›› Water vapor pressure shall be  $P(\text{H}_2\text{O}) < 2 \times 10^{-8}$  torr @ 150°C at the end of the bake.

# TREND OF $P_{H_2O}$ DURING BAKE (CALCULATION) FOR BT BAKEOUT

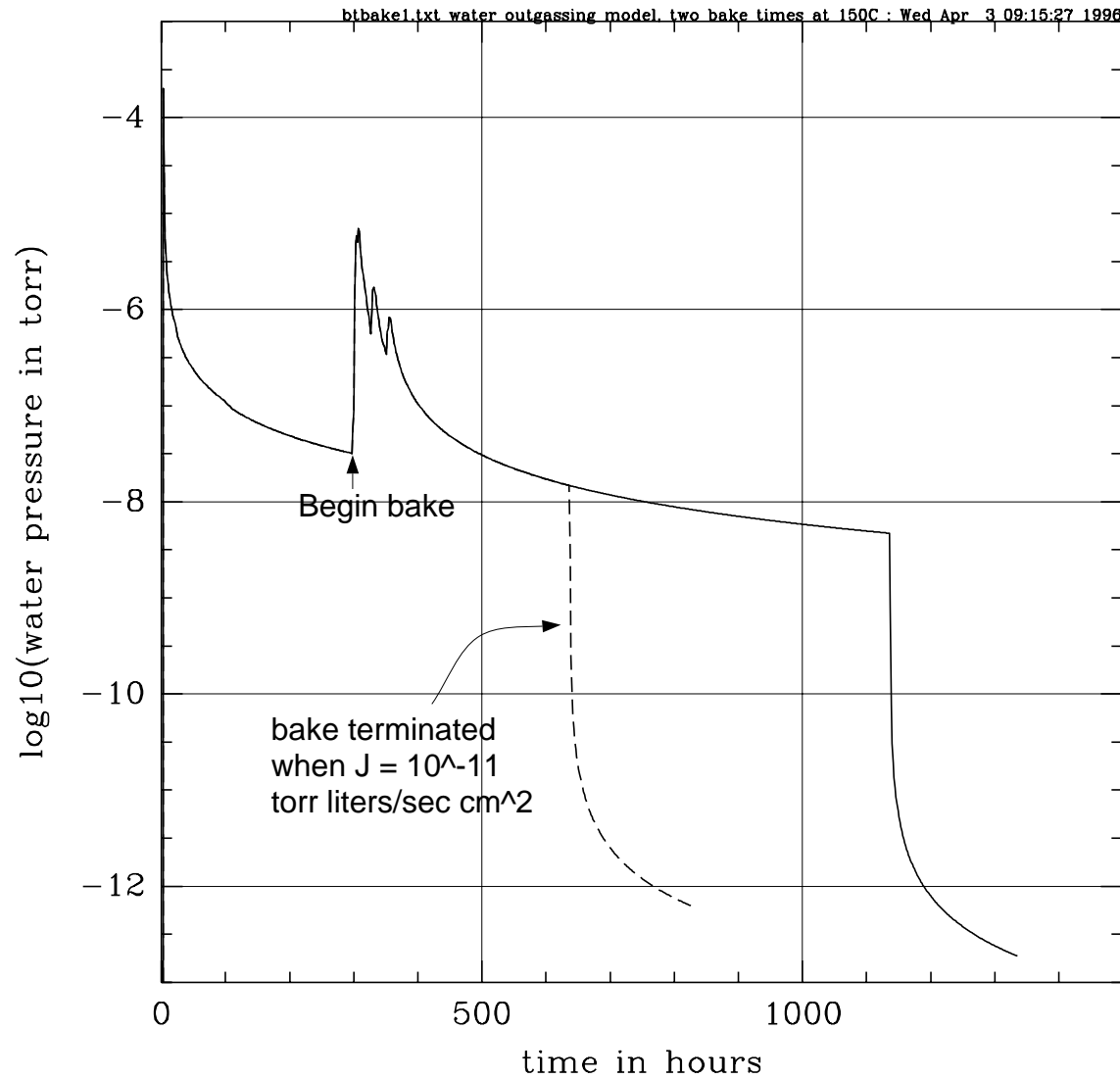

waterbake.f model for beamtube bake at 150C. Liquid Nitrogen traps at the 10 inch ports every 250 meters.,  $F = 2500$  liters/sec/port  
Model parameters:  $T_0 = 9000K$ ,  $R = 0.7$ ,  $\sigma = 45$  monolayers at  $t = 0$

# DESIGN REQUIREMENTS (con't)

---

- **BAKE TEMPERATURE**

- ›› Minimum temperature at any surface shall be  $> 130^{\circ}\text{C}$
- ›› Maximum temperature of the beam tube wall shall be  $< \text{TBD}$  ( $170^{\circ}\text{C}$ )
- ›› Maximum temperature of the beam tube bellows shall be  $< \text{TBD}^{\circ}\text{C}$
- ›› Maximum temperature at any point on the 122 cm gate or gate valve shall not exceed  $170^{\circ}\text{C}$

- **MAXIMUM DIFFERENCE IN TEMPERATURE OF THE BEAM TUBE WALL**

- Axial gradients

- ›› To avoid axial mechanical overstress, the average temp of the beam tube wall of any individual section between fixed supports not differ from the average temp of any other section by more than  $25^{\circ}\text{C}$  (TBD).



# DESIGN REQUIREMENTS (con't)

---

## - Radial gradients

- ›› To avoid transverse mechanical overstress, the average temp of any semicylindrical half of any individual section between sliding supports shall not differ from the average temp of its other semicylindrical half by more than 6°C.

# Distribution of Hyspan expansion joints spring constants, first 42 articles

---

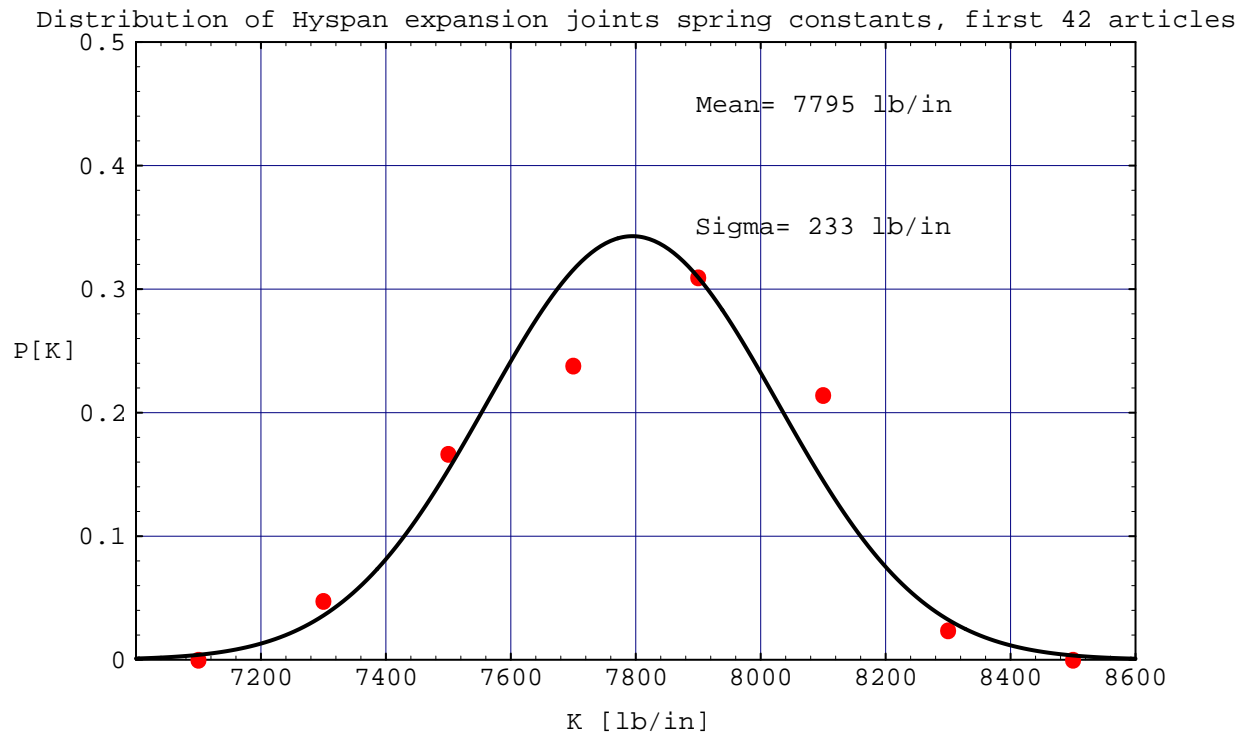

# Axial force at fix supports with tube sections between adjacent pairs of supports alternating temperatures (for $dT = 25^\circ\text{C}$ )

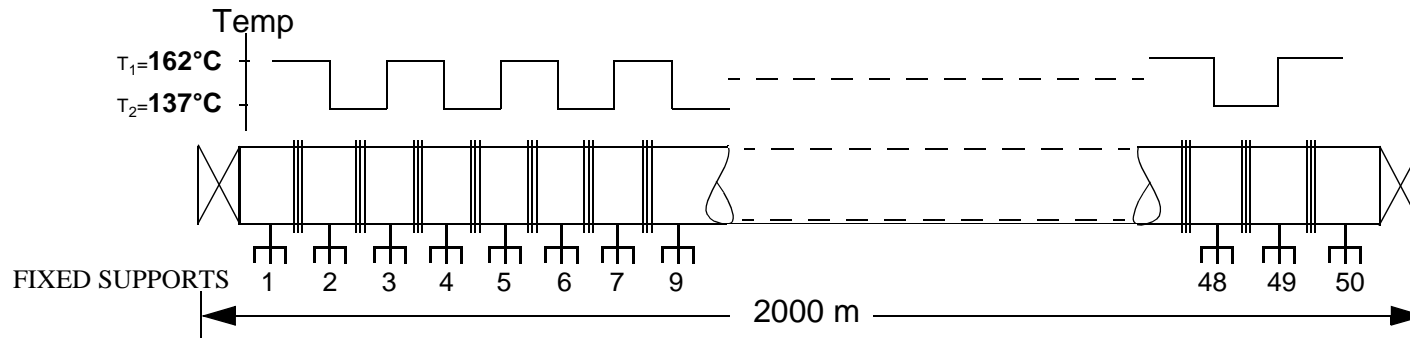
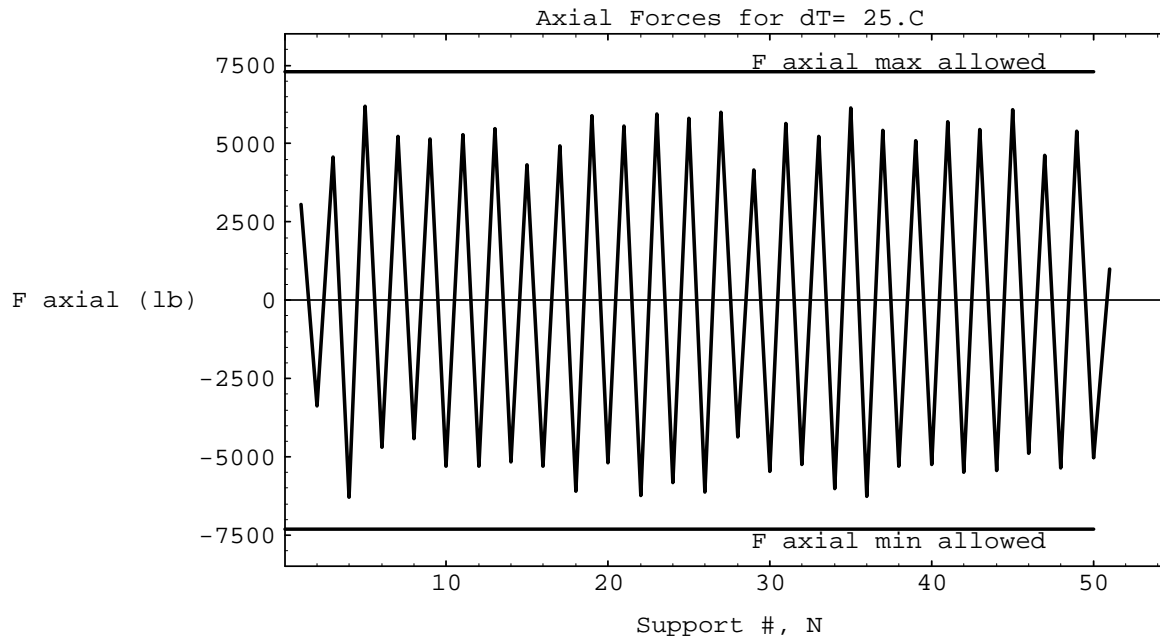

# Transverse Forces at fixed and swinging supports

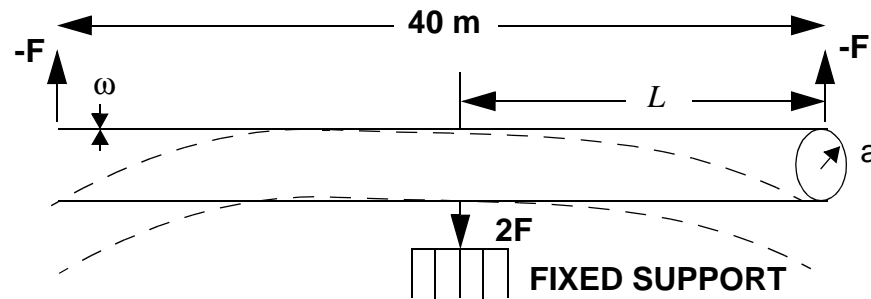

PLAN VIEW (SCHEMATIC)

## Single supported tube end

$$F(\Delta T) = \frac{3\pi Y a^3 \omega \alpha}{2L} \cdot \frac{\Delta T}{\Delta z}$$

Y = Young's modulus of steel

a = tube radius

$\alpha$  = thermal expansion coefficient

$\omega$  = thickness of tube wall

L = tube length

$\Delta T/\Delta z$  = thermal gradient across tube

F = force (cantilevered end)

$$F(\Delta T) = (114 \text{ lb}/^\circ\text{C})\Delta T$$

**Force at fixed support:**

$$2F = (228 \text{ lb}/^\circ\text{C})\Delta T$$

**For max force at support = 1372 lb**

$$\Delta T = 6^\circ\text{C}$$

# DESIGN REQUIREMENTS (con't)

---

- **BAKE DURATION**

- ›› The coldest spot of the module under bake shall be maintained  $T > 130^{\circ}\text{C}$  for the earlier of either:
  - an elapsed time of 30 days, or
  - a water outgassing rate  $J(\text{H}_2\text{O}) < 1 \times 10^{-11}$  torr l/s  $\text{cm}^2$  at  $150^{\circ}\text{C}$ .
- ›› If the temp of any monitoring sensor falls below the minimum bake temperature, the bake time shall be extended as needed to ensure minimum time requirement is met.

# DESIGN REQUIREMENTS (con't)

---

- DATA ACQUISITION, DISPLAY, MONITORING & RECORDING
  - ›› Wall temperatures at representative positions (including anticipated hot or cold spots)
  - ›› Temperature interfaces at the end gate valves, supports and pump port hardware
  - ›› Temperatures at the 122 cm gate valves and terminations
  - ›› At least one RGA to measure partial pressures of  $H_2$  and  $H_2O$  (during bakeout) through AMU 100 (post-bake)
  - ›› Measure DC power supply currents and voltages
  - ›› Operating status of equipment (i.e., vacuum pumps)[state vector]
  - ›› Other engineering data (e.g., ambient environment conditions)

# DESIGN REQUIREMENTS (con't)

---

- **BEAM TUBE INSULATION**

- ›› Insulation as required to achieve the bake temperature limits.

- **VACUUM COMPONENTS**

- ›› All vacuum components shall comply with the LIGO Vacuum Equipment Specification, section 5, for similar components.

# BAKEOUT INTERFACES

---

- **MECHANICAL**

- ›› Vacuum hardware shall be compatible with the BT module pump ports hardware, Type H, as called out in drawing D950027.
- ›› Electrical connection for delivering DC heating power to the BT module shall use bolted attachments via holes drilled through BT Support Rings near each pump port (these holes are not part of the present BT fabrication).
- ›› Temperature sensors shall be attached to the BT wall using TBD technique.

- **ELECTRICAL**

- ›› Step-down transformers shall be used to provide needed AC power (480VAC, 3Ø, 120VAC, 1Ø) from the site power.
- ›› The beam tube shall be grounded at the ends only during the bake. [R to ground  $\leq 0.035$  ohm everywhere]



# BAKEOUT INTERFACES (con't)

---

- ›› The beam tube shall have electrical connection to DC power supplies for heating.
- ›› Monitoring and recording devices shall use separate AC power (110-120VAC, 1Ø), also derived from site utilities power.
- ›› The bakeout equipment shall have adequate protection from lightning.

# DIAGRAM OF EQUIPMENT DURING BAKEOUT AND COOLDOWN

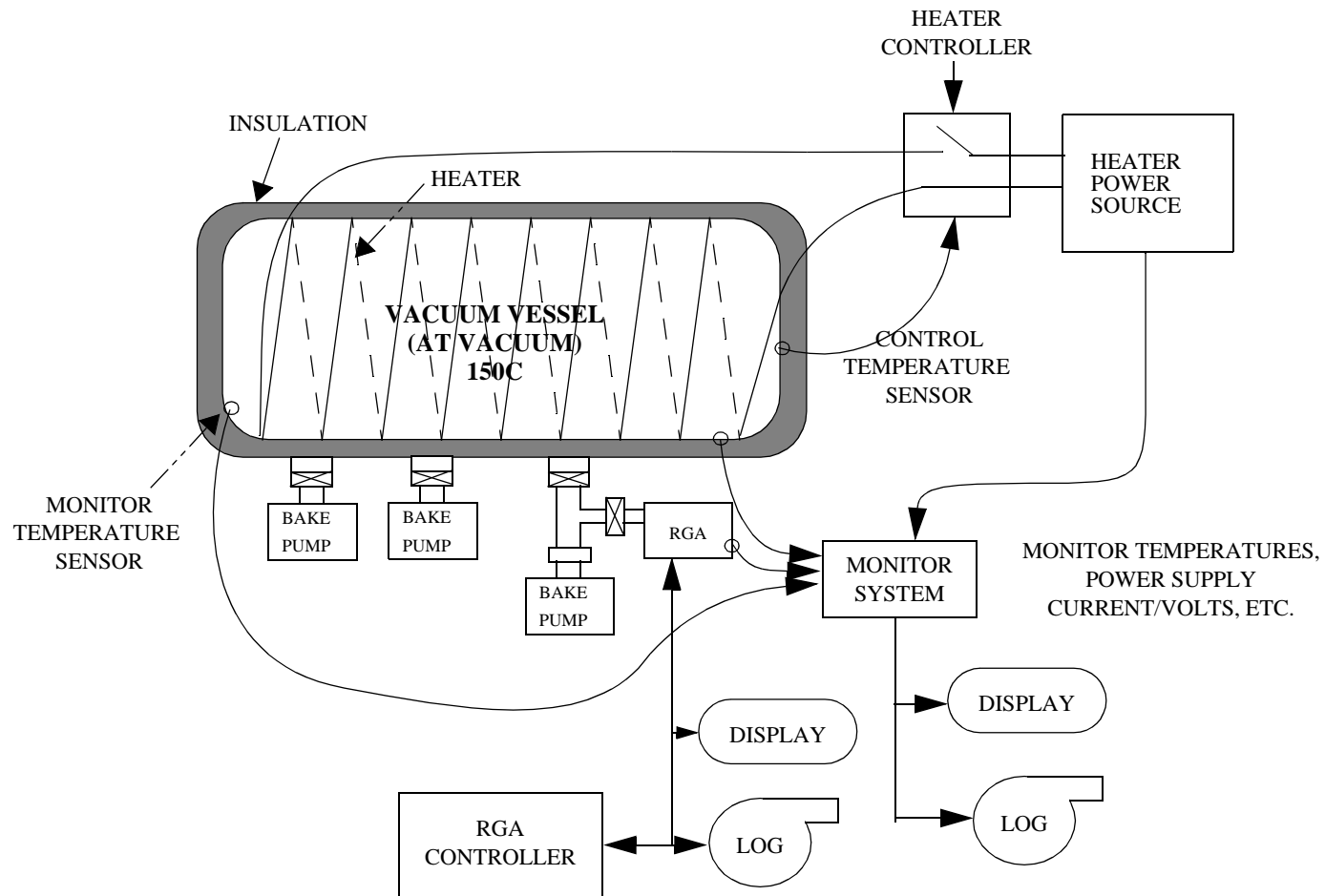

# TUBE WALL INSULATION

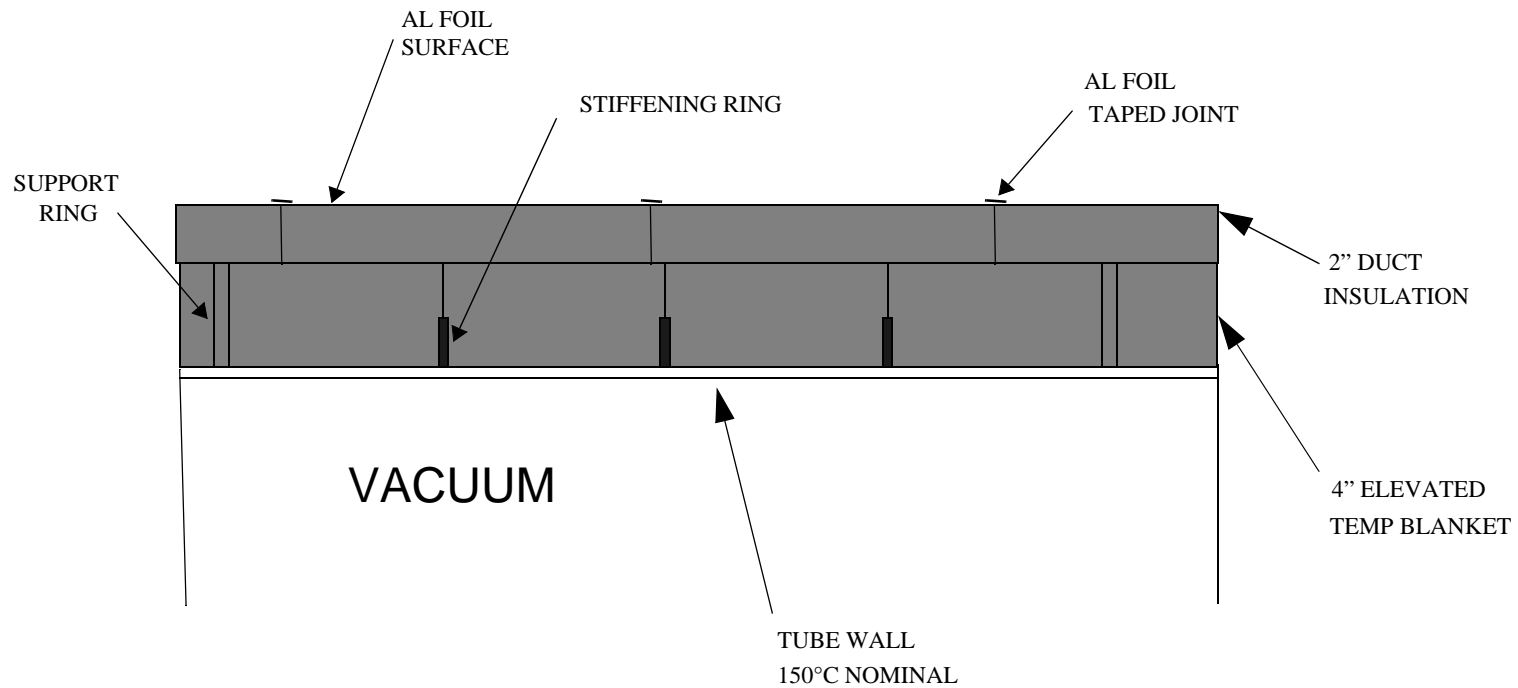

# BELLOWS INSULATION

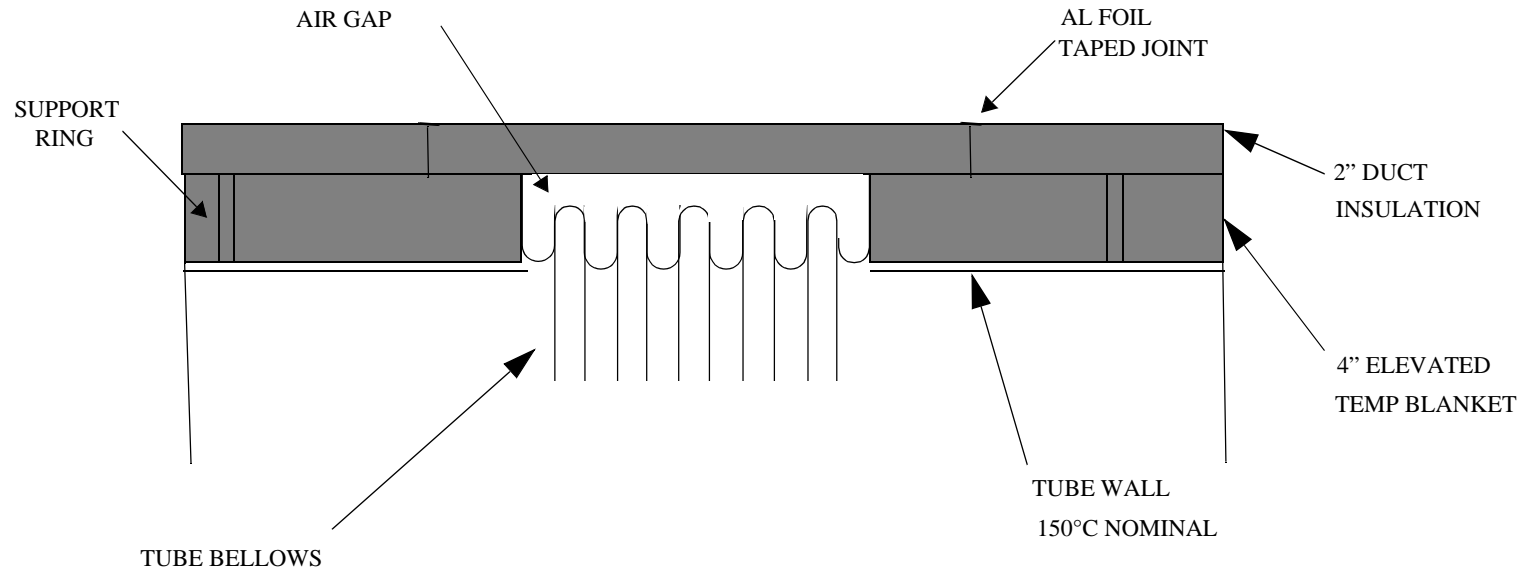

# BEAM TUBE BAKEOUT ELECTRICAL HEATING POWER

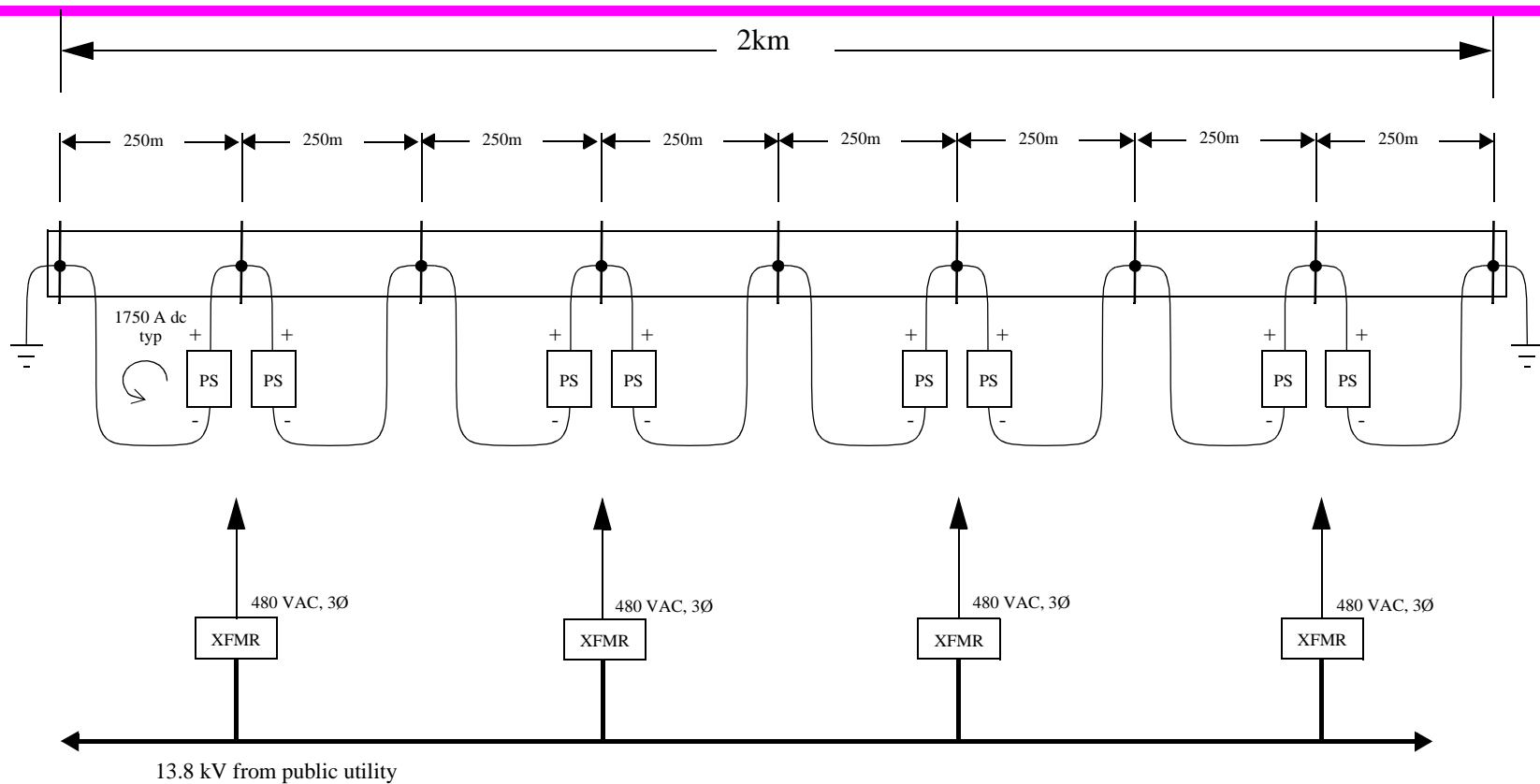

AC POWER NEEDED TO MAINTAIN  $T=150^{\circ}\text{C}$ :

4 x 165 kVA = 660 kVA (summer days)

4 x 213 kVA = 852 kVA (summer nights)

4 x 240 kVA = 960 kVA (winter nights)

4 x 330 kVA = 1320 kVA (winter nights, coldest ambient temp)

Legends:

PS Low voltage, high current  
DC power supply

XFMR Power Transformer

# BEAM TUBE BAKEOUT ELECTRICAL POWER FOR PUMPS AND INSTRUMENTATION

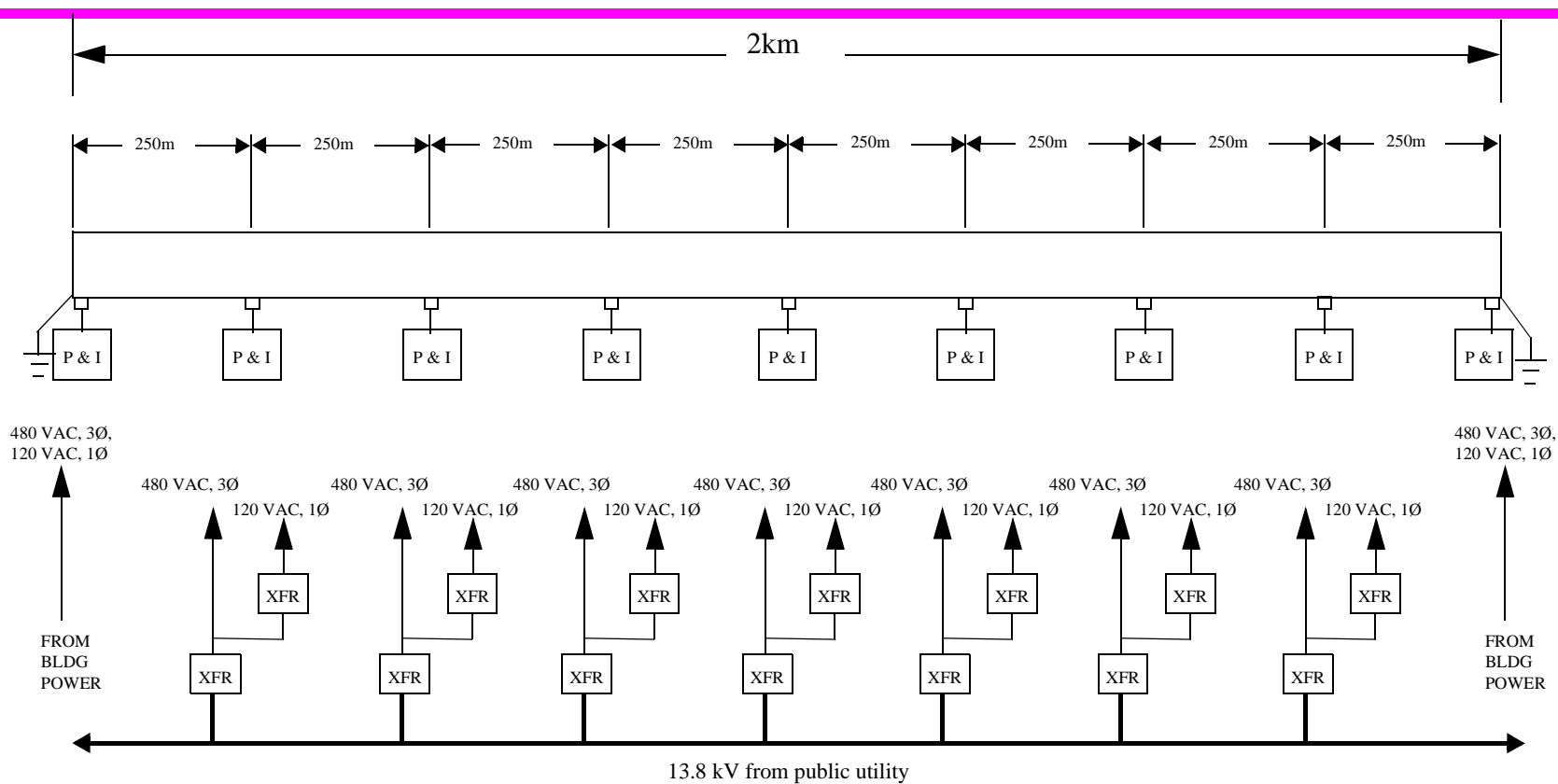

Legends:

□ Pump Port

□ P & I Pumps & Instrumentation

# DC POWER SUPPLIES SET-UP 250 M CONFIGURATION

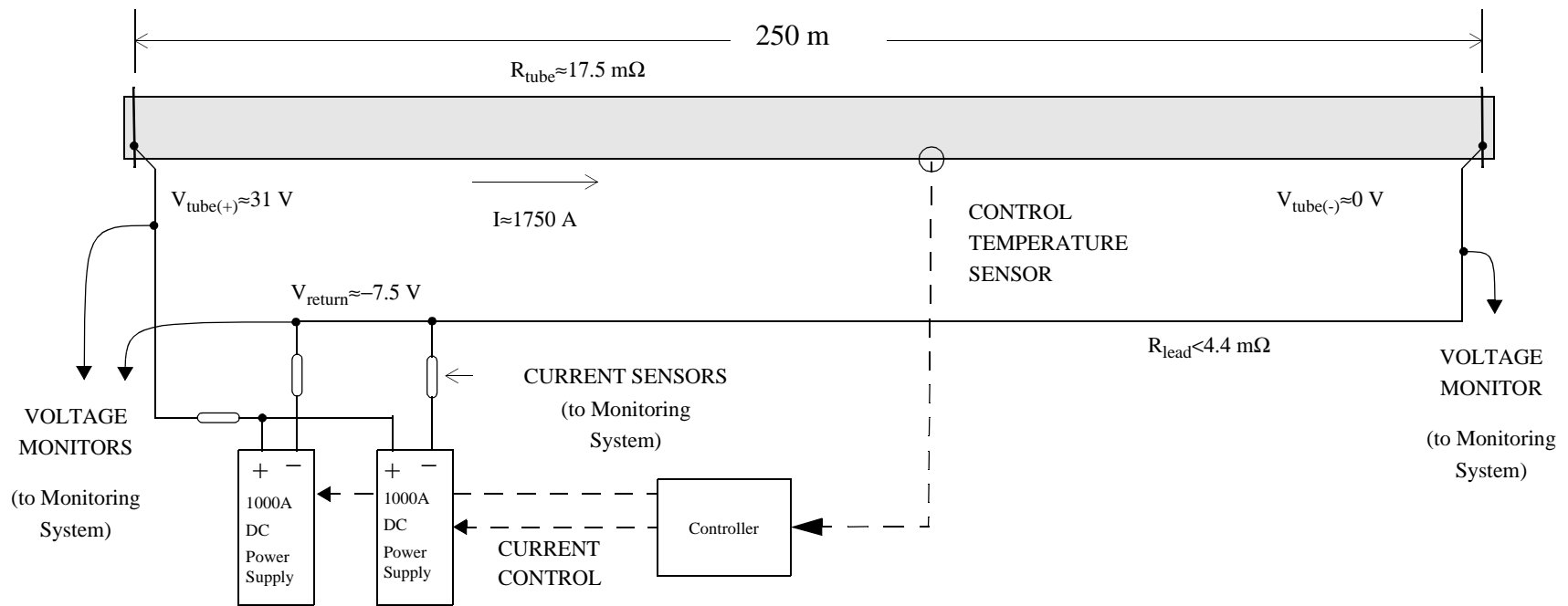

# SCHEMATIC OF VACUUM PUMPS AND RGA DURING BAKEOUT

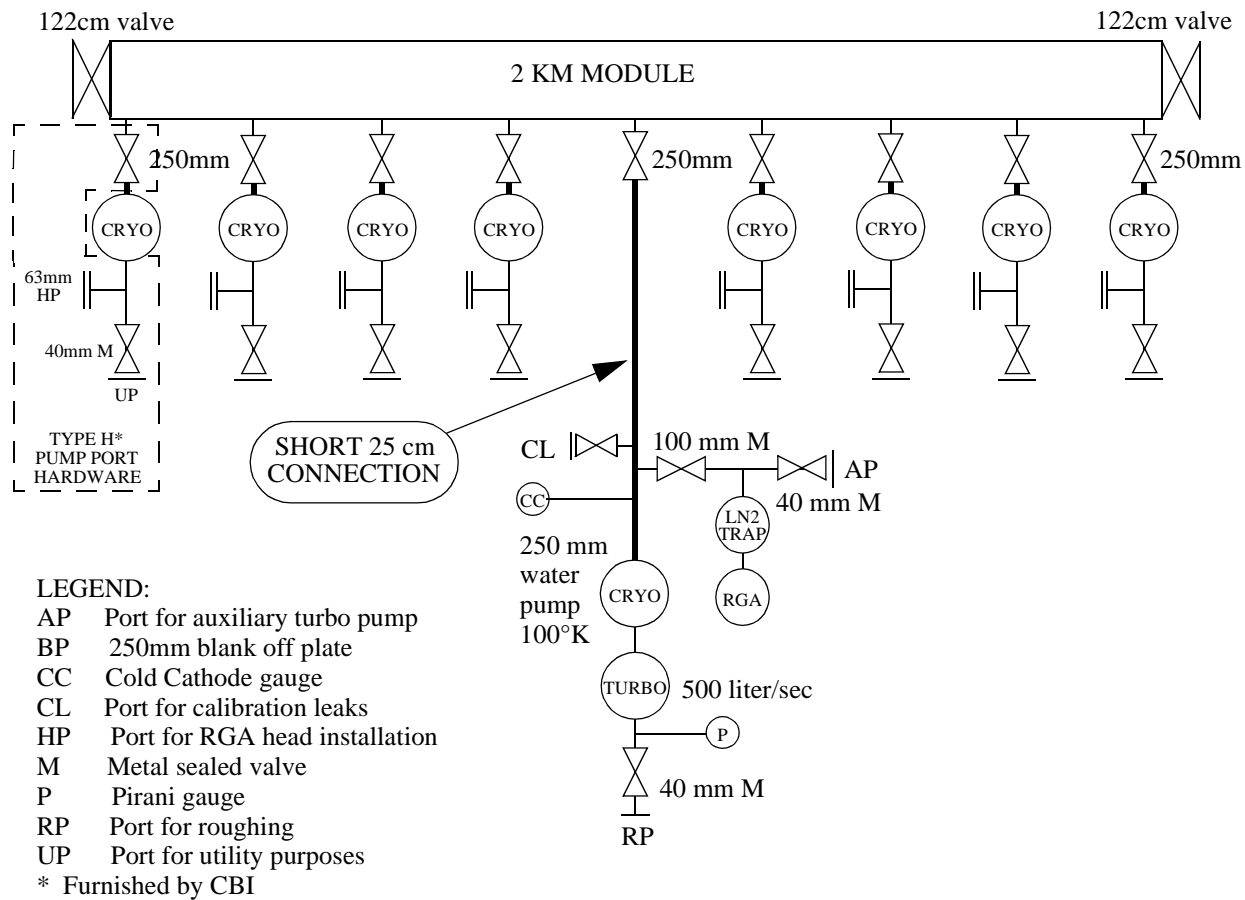



# MONITORING SYSTEM

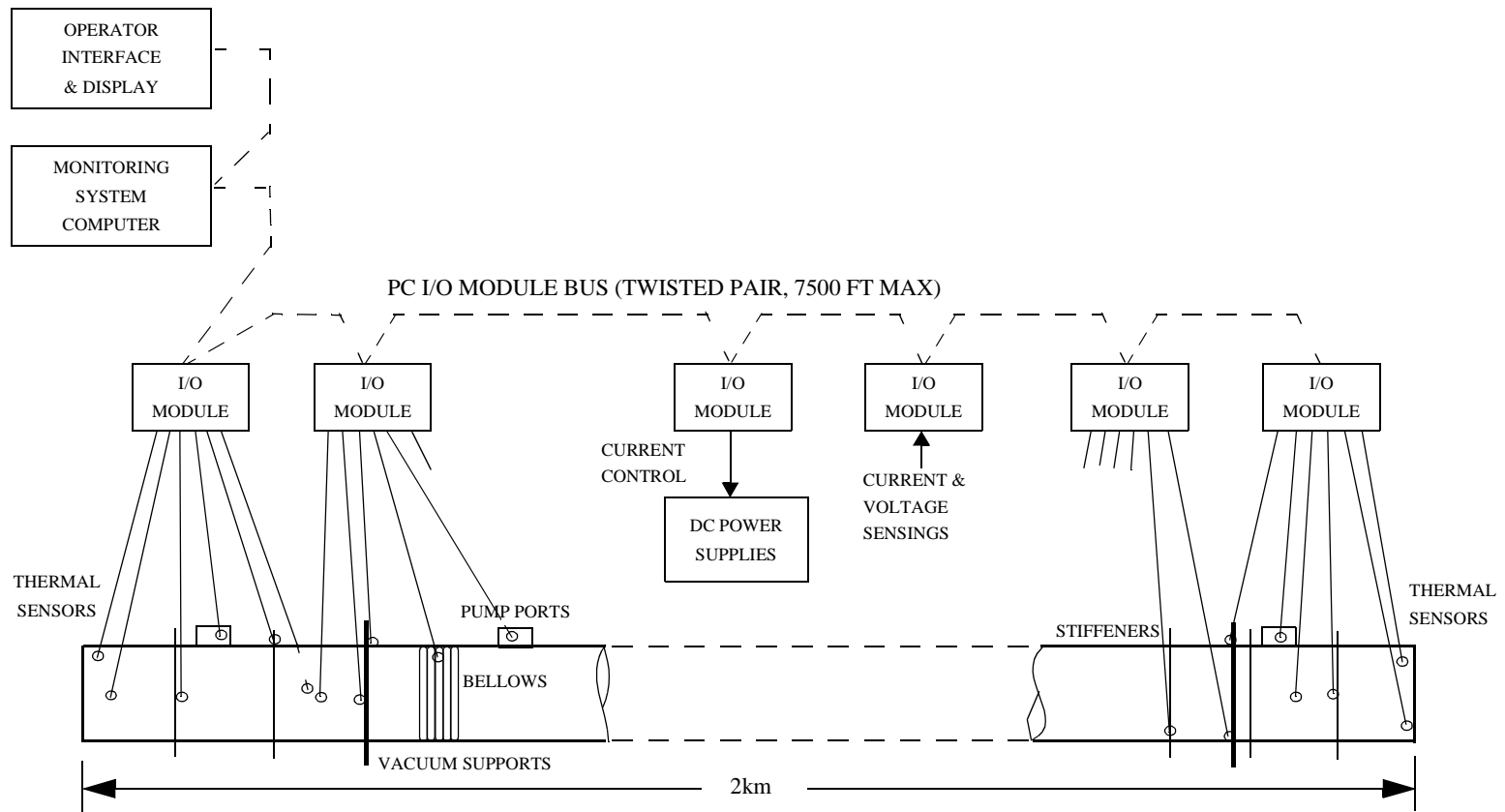

# DIAGRAM OF EQUIPMENT DURING POST-BAKE MEASUREMENTS

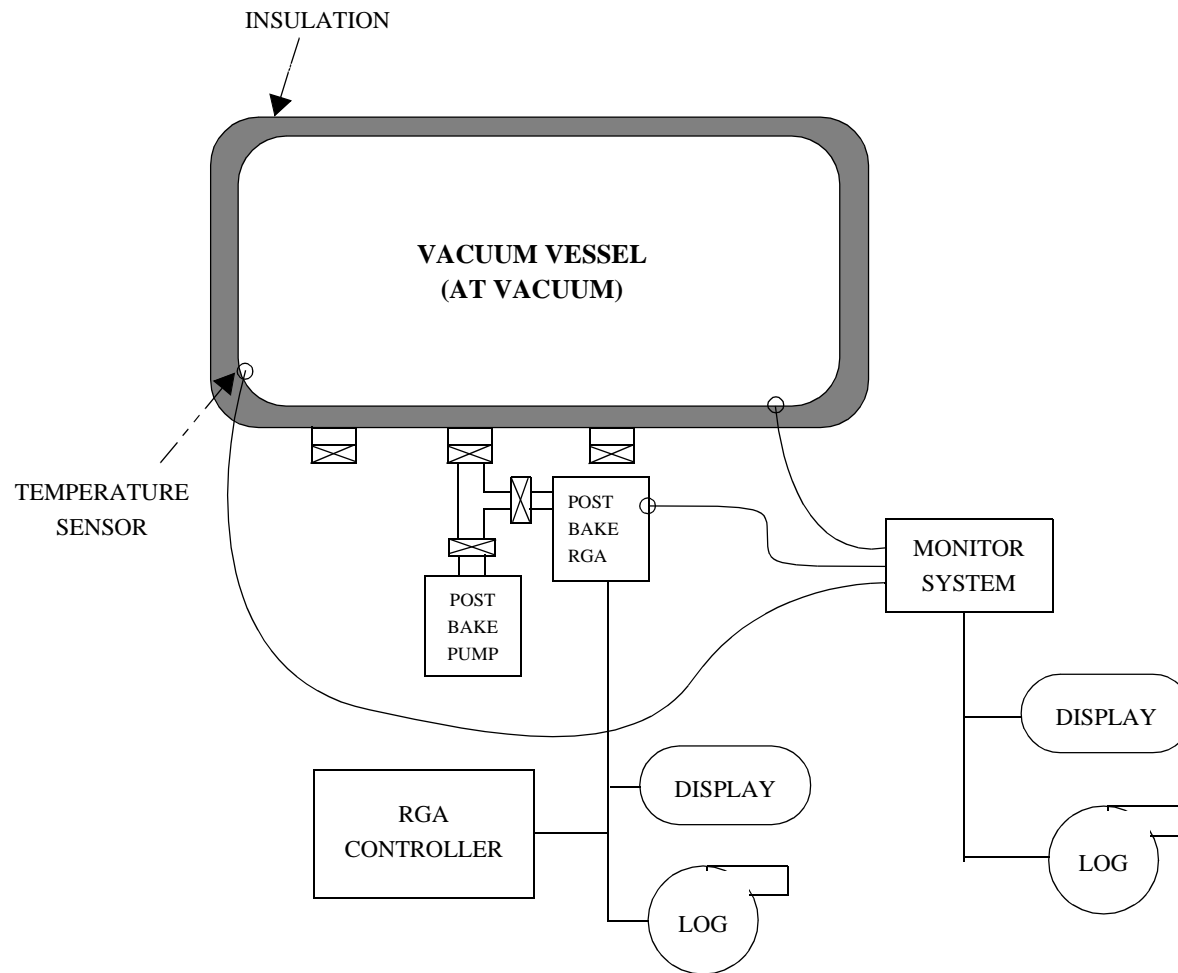

# FINAL (POST-BAKE) TEST CONFIGURATION

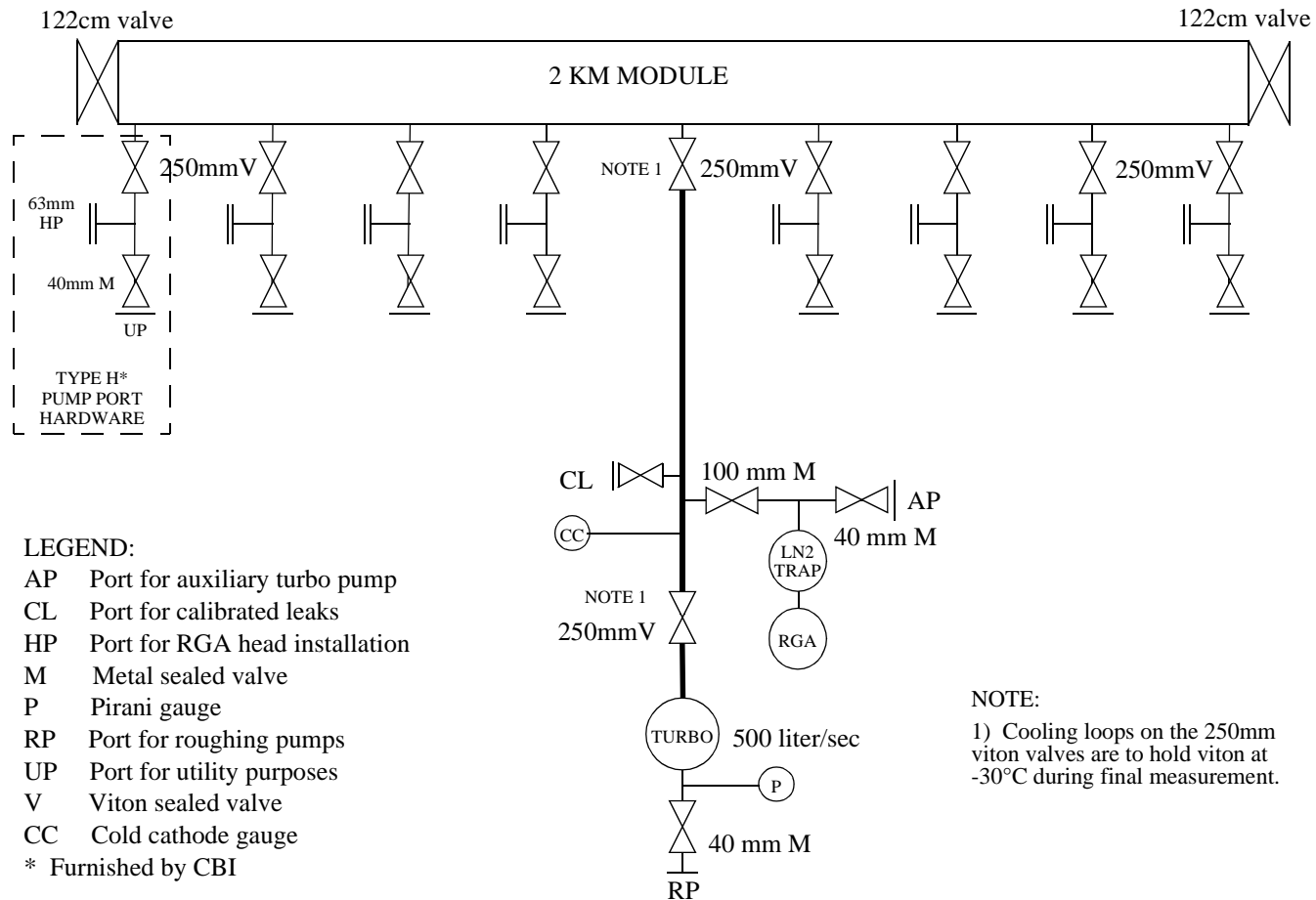

# PORTABLE CALIBRATION MODULE

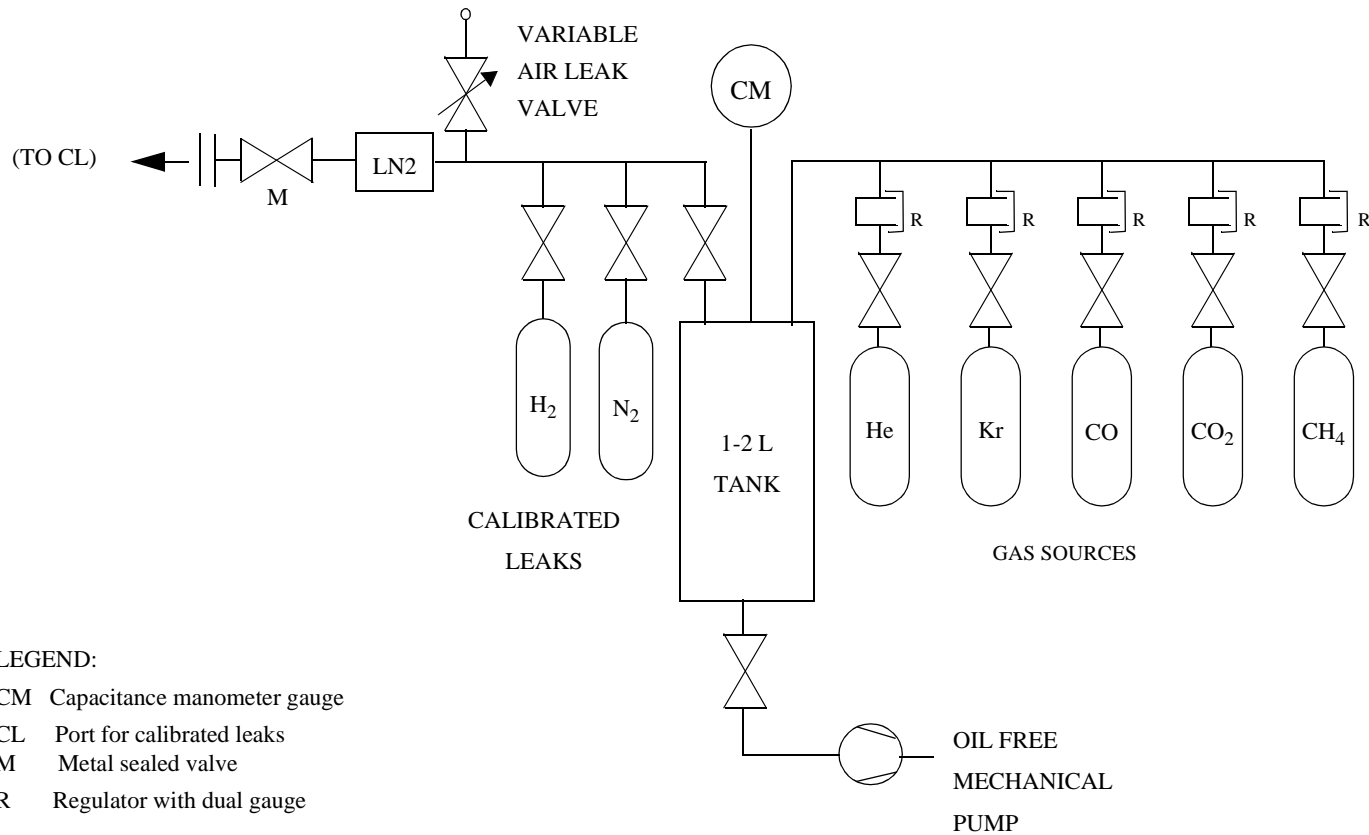

# LEAK LOCALIZATION TEST CONFIGURATION

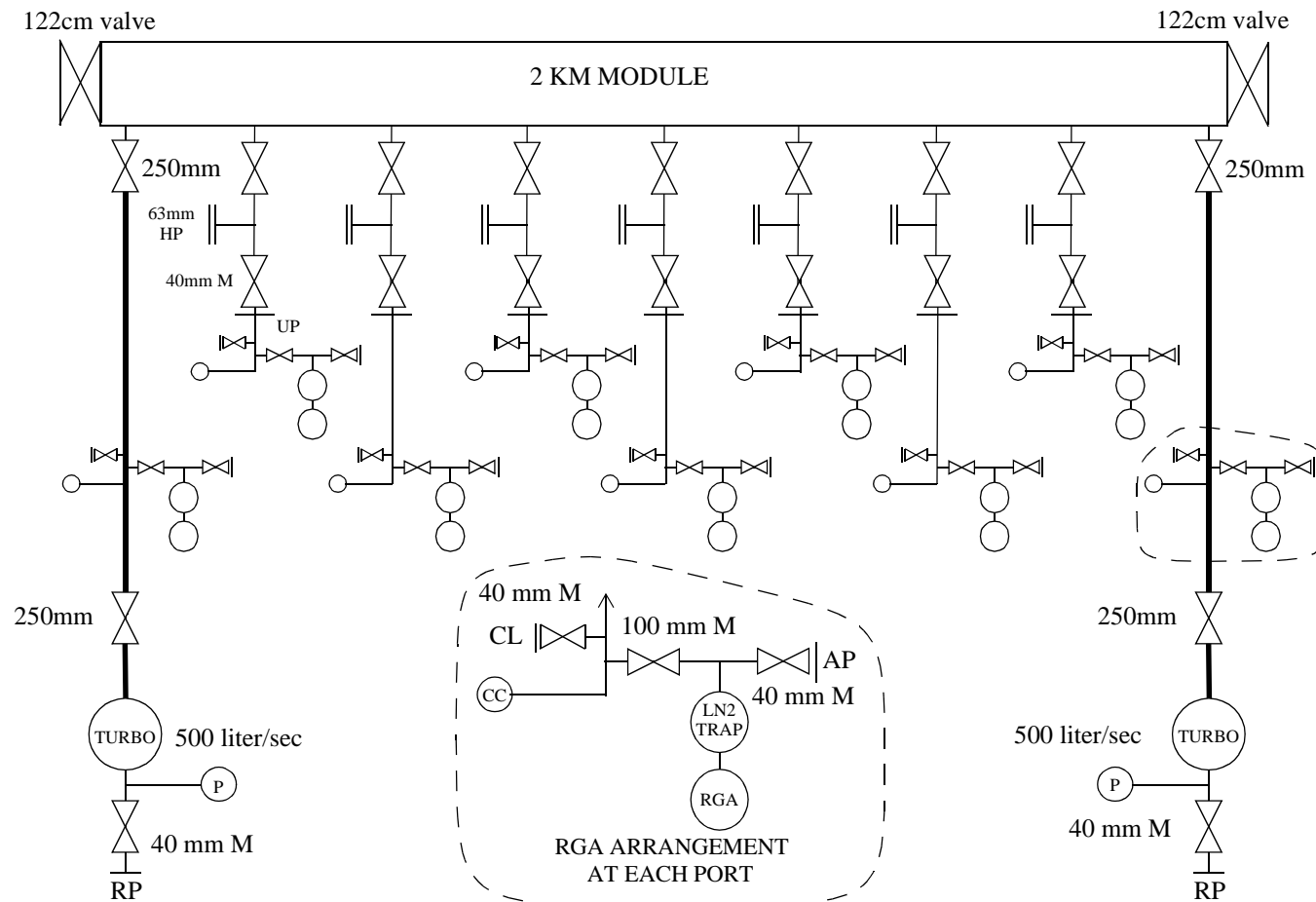

### SUMMARY INTEGRATED SCHEDULE

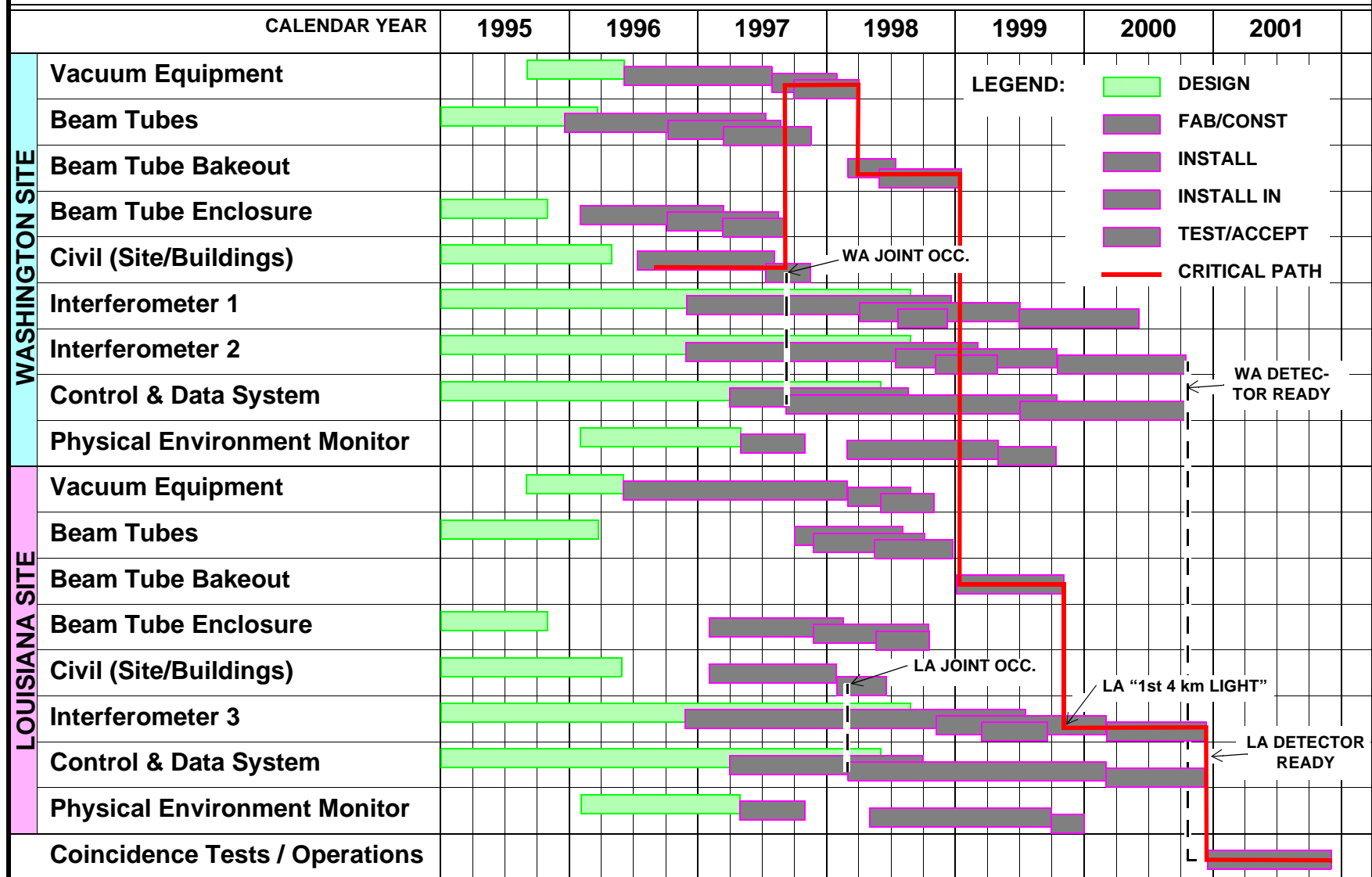

# SCHEDULE

---

## DESIGN ACTIVITIES

- Design requirements and conceptual design:
  - ›› Document design and performance requirements, review BTD and QT experience, develop complete conceptual design.
  - Design Requirements Review/Conceptual Design Review **12/96**
- Preliminary design:
  - ›› Perform trade studies, optimize design, develop subcontracting plans, resolve all technical issues.
  - Preliminary Design Review **2/97**
- Detailed design:
  - ›› Document design details, procedures and test criteria, solicit subcontract proposals/bids.
  - Final Design Review **6/97**

### BAKEOUT TIMELINE - FIRST MODULE

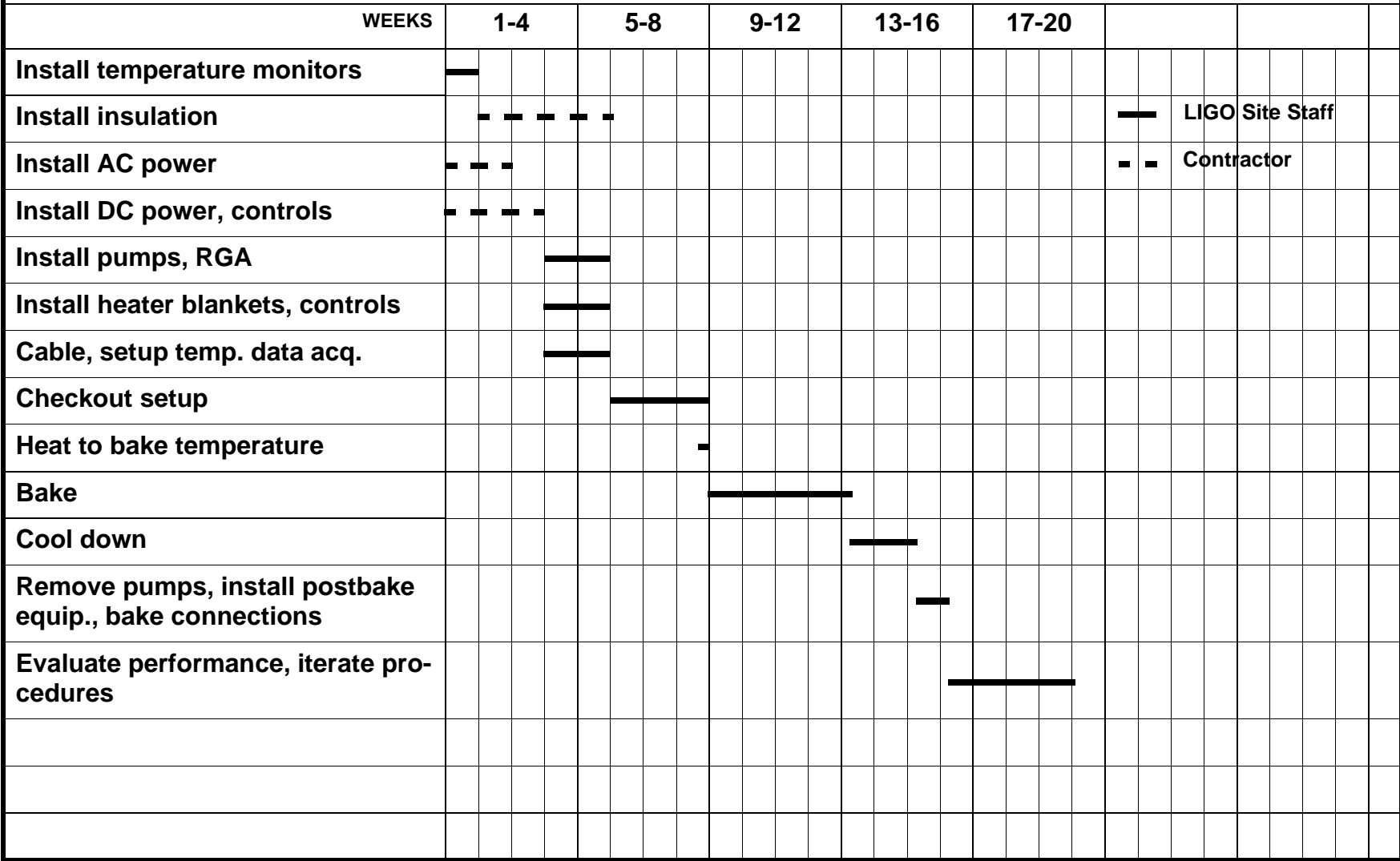



## BAKEOUT TIMELINE - MODULES 2-4

