

---

# **The Detection of Gravitational Waves**

-----

# ***LIGO***

-----

**Barry Barish**  
***NRC BPA / Irvine, CA***  
***Nov 2, 1996***



# LIGO

## *Introduction*

---

- Laser Interferometer Gravitational Wave Observatory
  - » **DIRECT** Detection of Gravitational Waves
- Joint Caltech/MIT Project funded by the National Science Foundation
- Under Construction
  - » Two Sites -- Louisiana and Washington

# Gravitational vs E.M. Waves

---

	EM WAVES	GRAV. WAVES
Nature	Oscillation of EM Fields Propagating Through Spacetime	Oscillations of the "fabric" of spacetime
Emission Mechanism	Incoherent superposition of waves from molecules, atoms, particles	Coherent emission by bulk motion of energy
Interaction with Matter	Strong absorption and Scattering	Essentially None!
Frequency Band	$f > 10^7 \text{Hz}$	$f < 10^4 \text{Hz}$

## ■ Implications

- ◆ Most gravitational sources not seen as electromagnetic (and vice versa)
- ◆ Potential for great surprises
- ◆ Uncertainty in strengths of waves

# Gravitational Wave

## *Forces*

---

### IF

- Detector Size  $\ll$  Wavelength  
(4 km) (300-30,000km)  
(10 kHz - 10 Hz LIGO)

### THEN

- Free Masses
- Quadrupolar Lines of Force

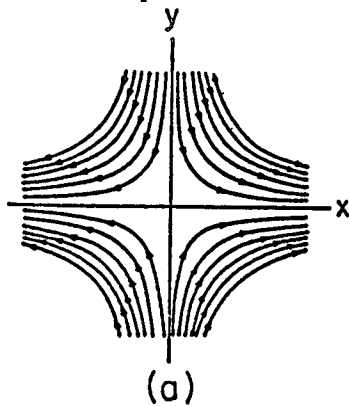

+ Polarization

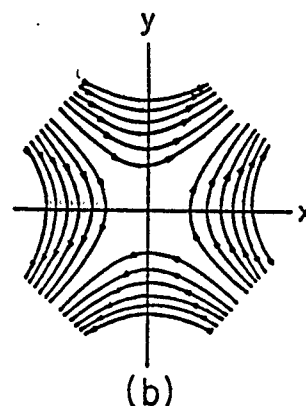

x Polarization

# Gravitational Waves

## *Two Polarizations*

---

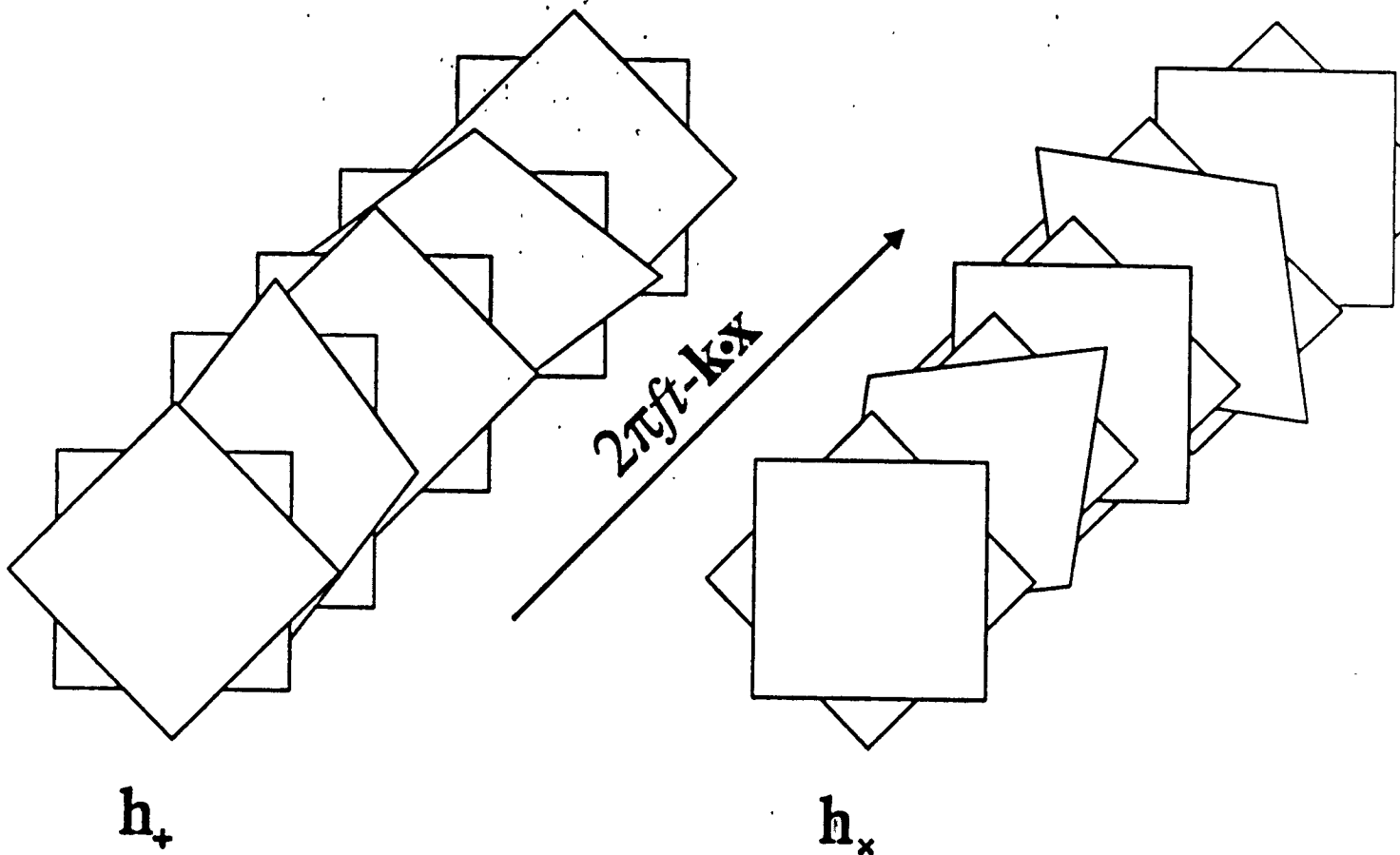

# Gravitational Waves

## *Effects*

- Displacement of free particles

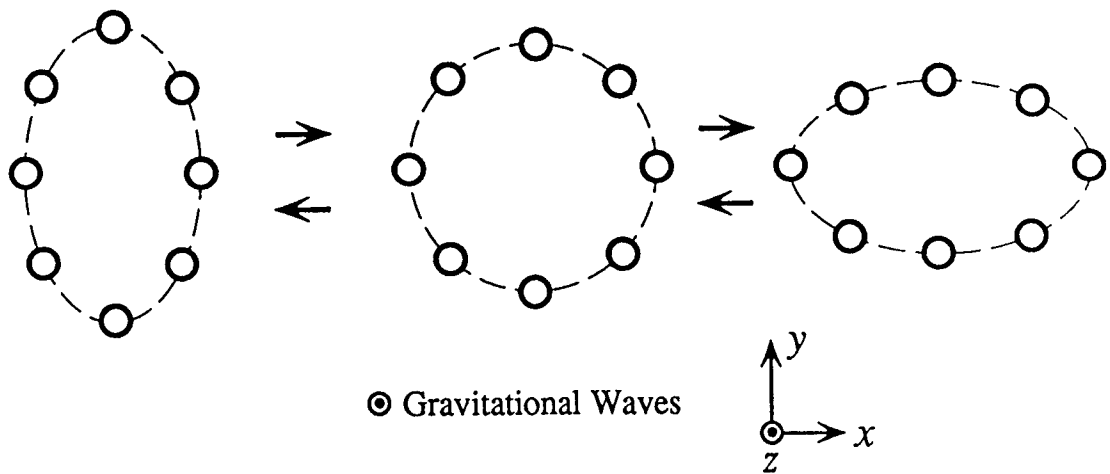

»  $h_+$  polarization

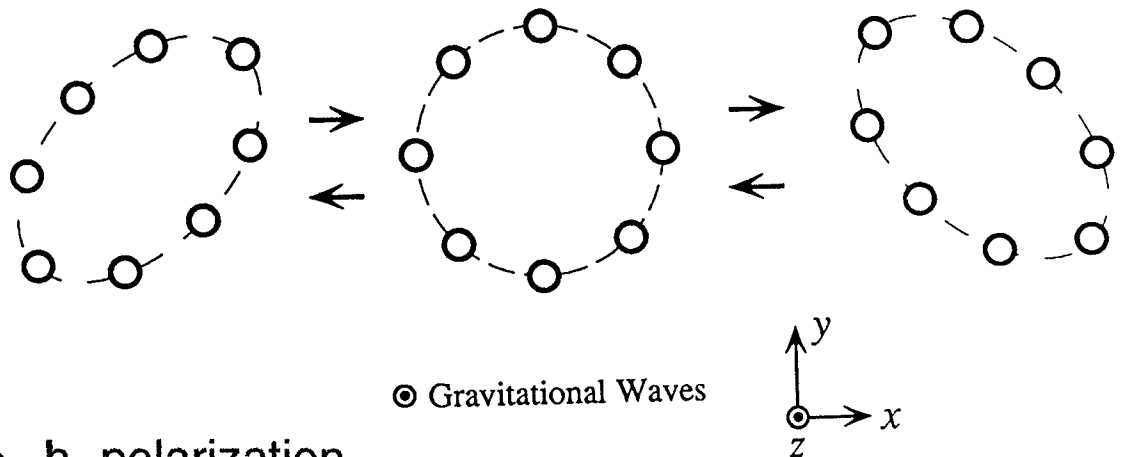

»  $h_x$  polarization

# Gravitational Waves

## *Detection*

---

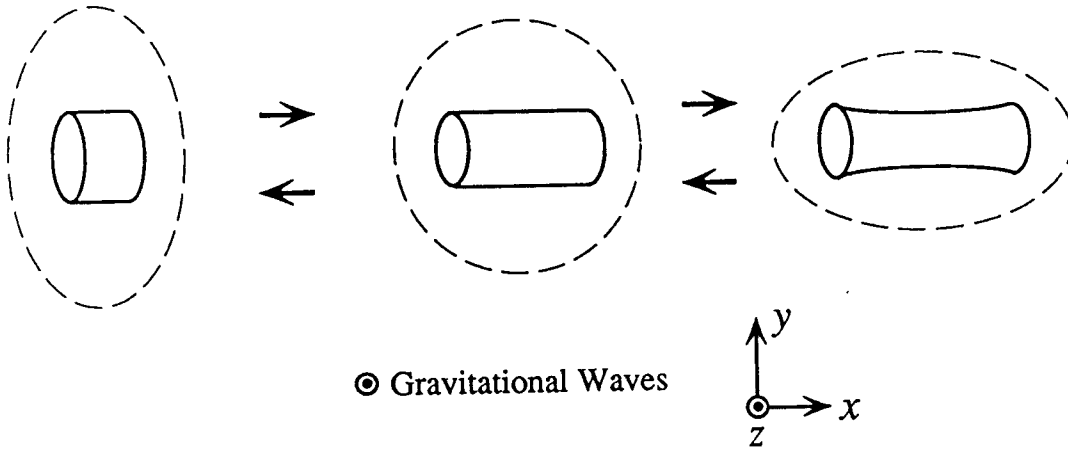

### ● Bar detector

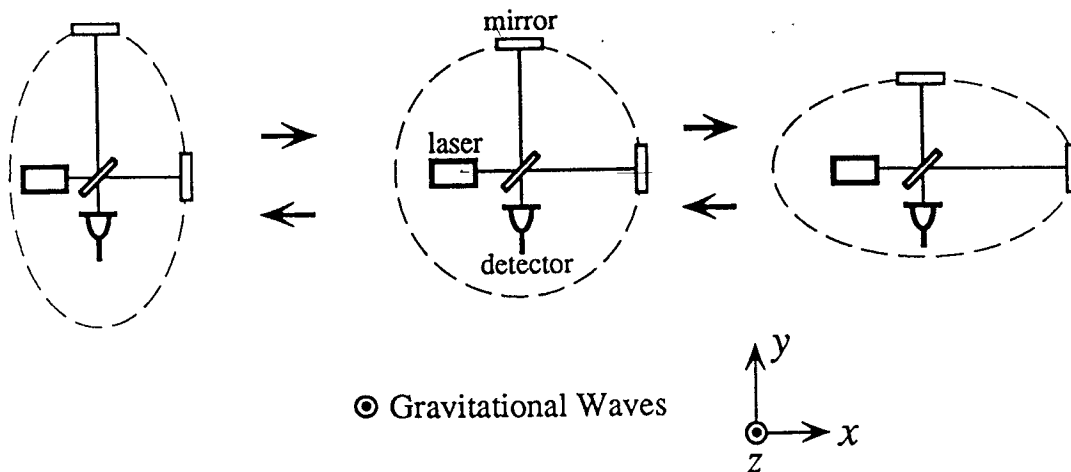

### ● Interferometer detector

# Gravitational Waves

## *Evidence*

---

- **Russell Hulse and Joseph Taylor**
- **Neutron Binary System**
  - » PSR 1913 + 16 -- Timing of Pulsars

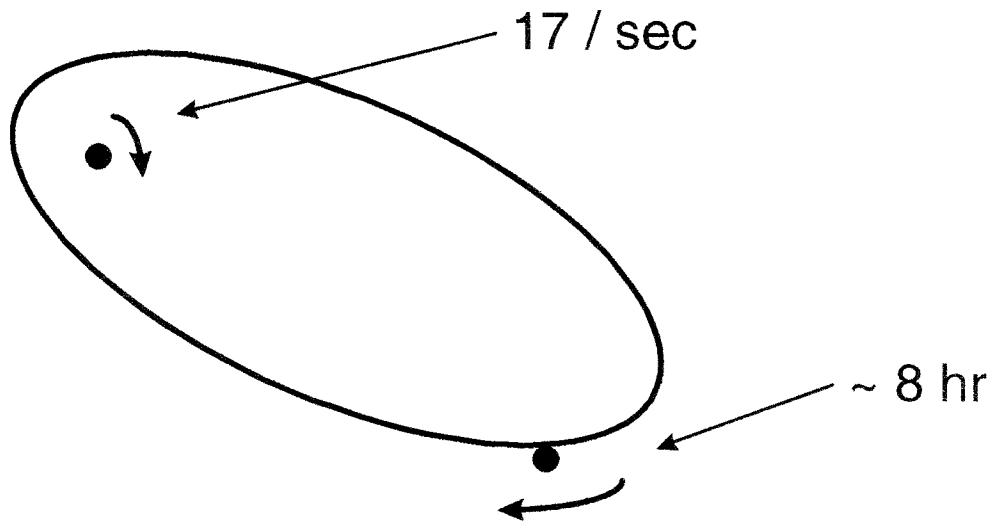



# Hulse and Taylor

## *Timing of Orbit*

---

- Speed up 10 sec in 15 years
  - » measured to  $\sim 50 \mu\text{sec}$  accuracy
- Deviation grows quadratically in time

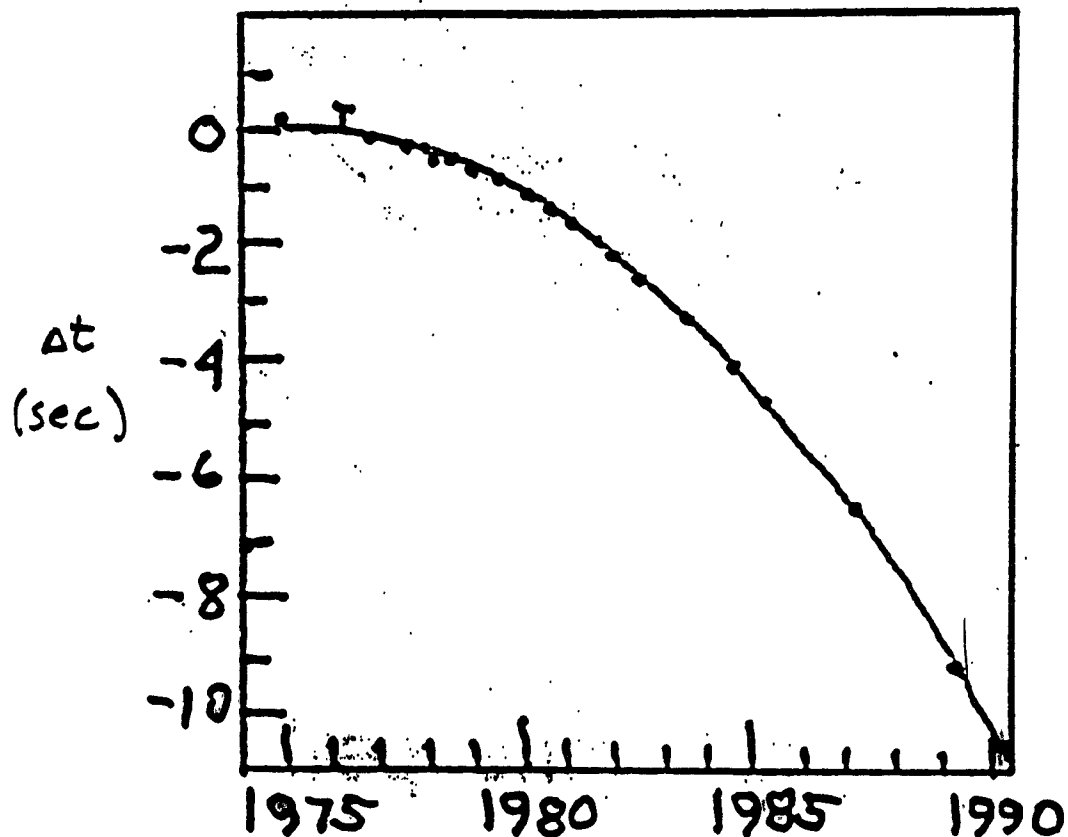

- Due to loss of orbital energy, from emission of gravitational waves

# Laboratory Experiment (a la Hertz)

---

## Laboratory Dumbbell System

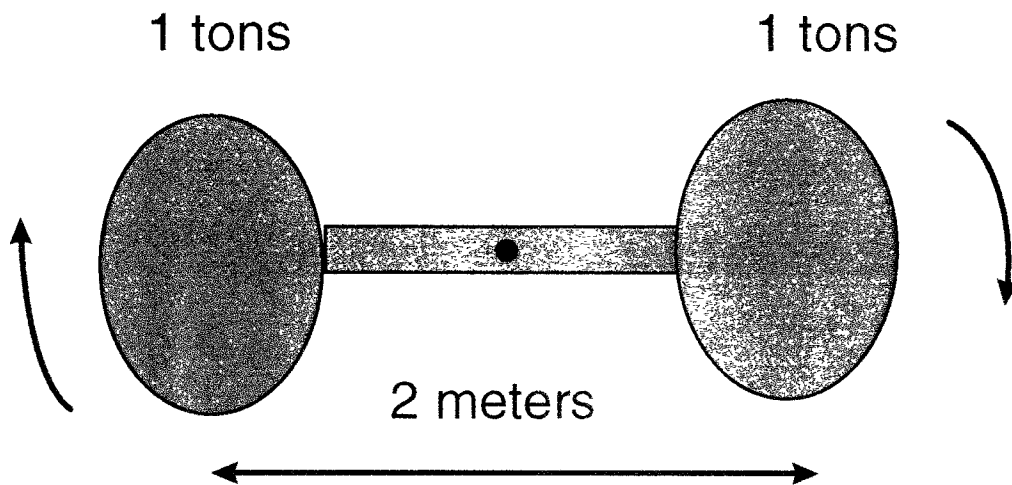

$$f_{\text{rot}} = 1 \text{ kHz}$$

$$h_{\text{lab}} = 2.6 \cdot 10^{-33} \text{ m} \times 1/R$$

$R$  = detector distance ( $> 1$  wavelength) = 300 km

$$h_{\text{lab}} = 9 \cdot 10^{-39}$$

This is too weak by about 16 orders of magnitude!

# Gravitational Waves

## *Sources and Detection*

---

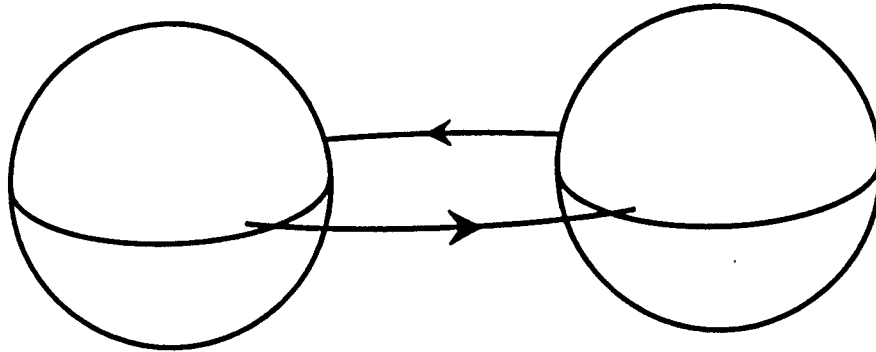

- binary star system

Sources	Frequency	$h$	Event Rate	Detection
Coalescing Binary Neutron Stars (200 Mpc)	10~1000 Hz	$10^{-22}$	~3/year	Interferometer + Template
Supernovae (in our Galaxy)	~1 kHz	$10^{-18}$	~3/century	Interferometer, Resonant
Supernovae (in Virgo)	~1 kHz	$10^{-21}$	several/year	Interferometer
Generation of Large Black Holes	~1 mHz	$10^{-17}$	1/year	Interferometer in Space
Pulsars	10~1000 Hz	$10^{-25}$	periodic	Interferometer, Resonant
Cosmic Strings	$10^{-7}$ Hz	$10^{-15}$	stochastic	Pulsar Timing

- sources and detection

# Astrophysical Sources

## *Frequency Range*

- Electromagnetic Waves - ~ 20 orders of magnitude (ULF radio -> HE  $\gamma$  rays)
- Gravitational Waves - ~ 10 orders of magnitude
- Combination of terrestrial and space experiments

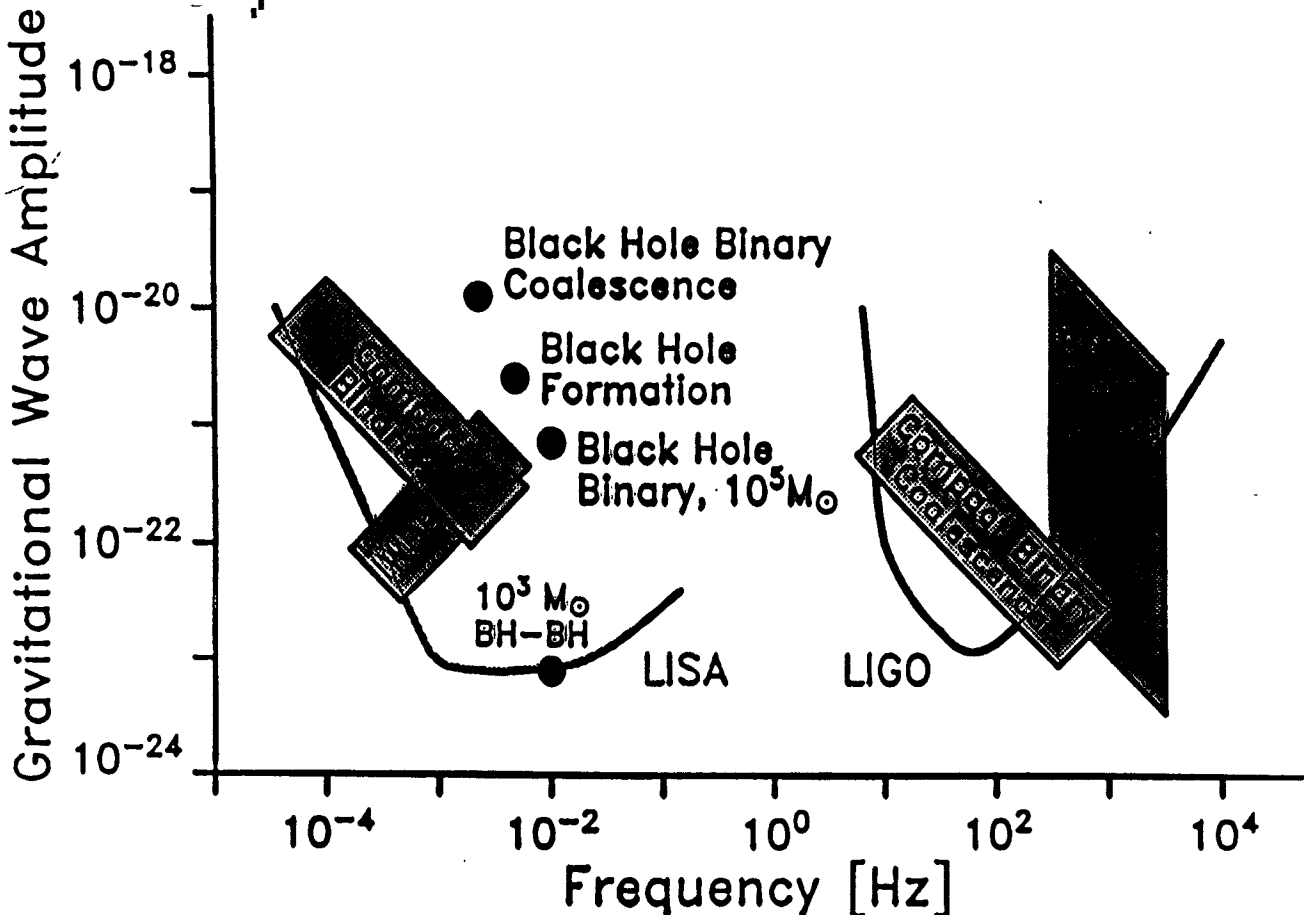

# Gravitational Waves

## *Space Experiment*

---

- LISA - Laser Interferometer Space Antenna
  - » six spacecraft in triangle (four needed)
  - » pair at each vertex

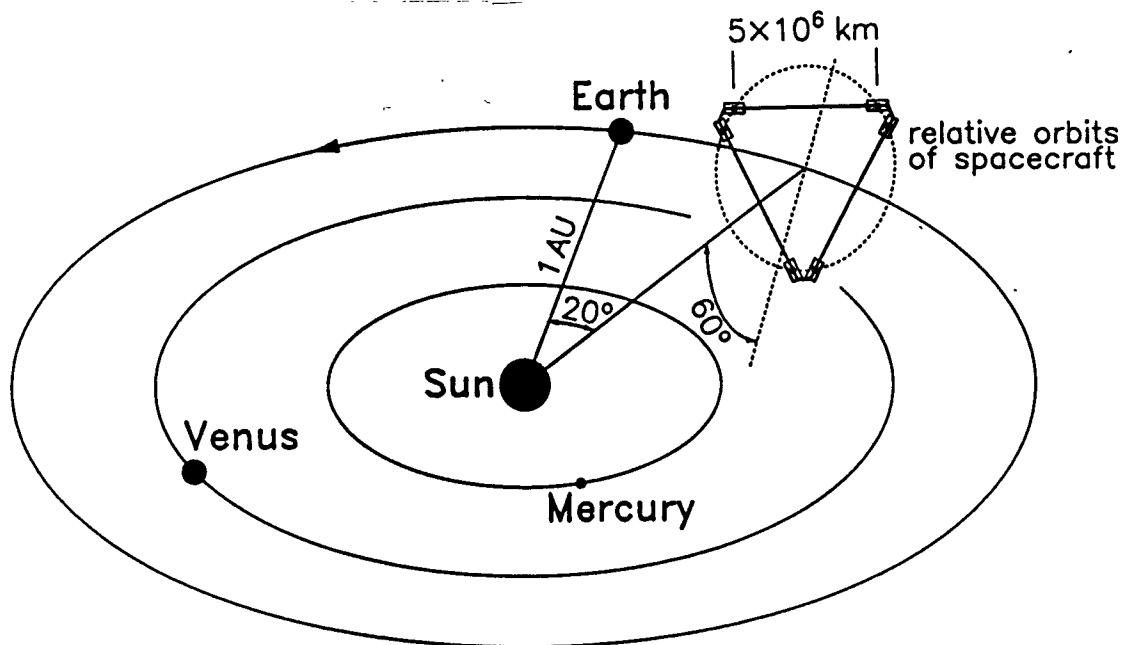

# LISA

## *Annual Revolution*

---

- 60 degree half opening angle
- 'tumbling' allows determination of position of source and polarization of wave

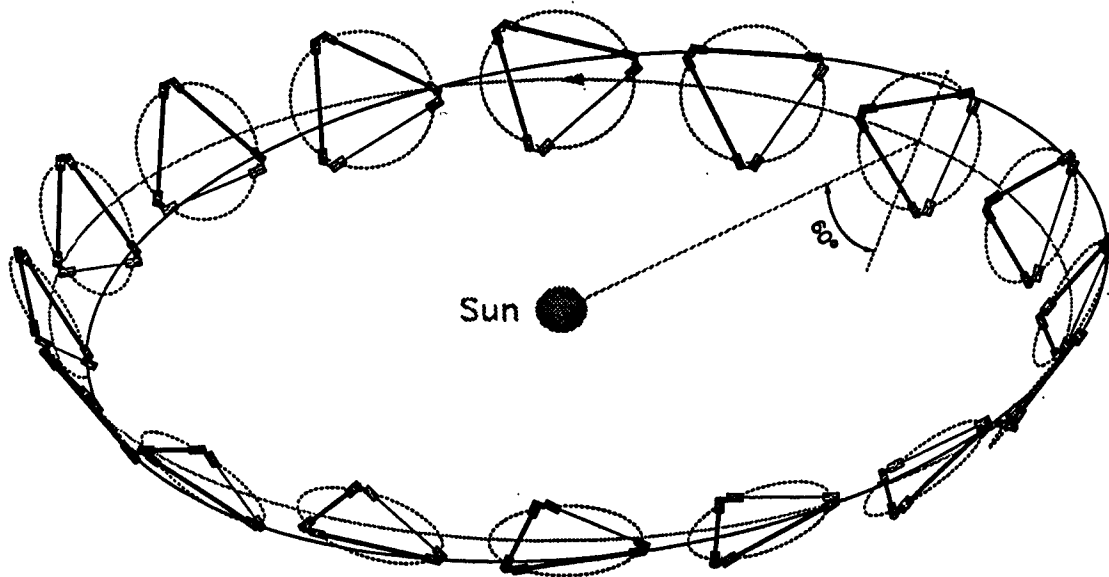

# Gravitational Waves

## *Resonant Bar Detector*

---

- Schematic Version

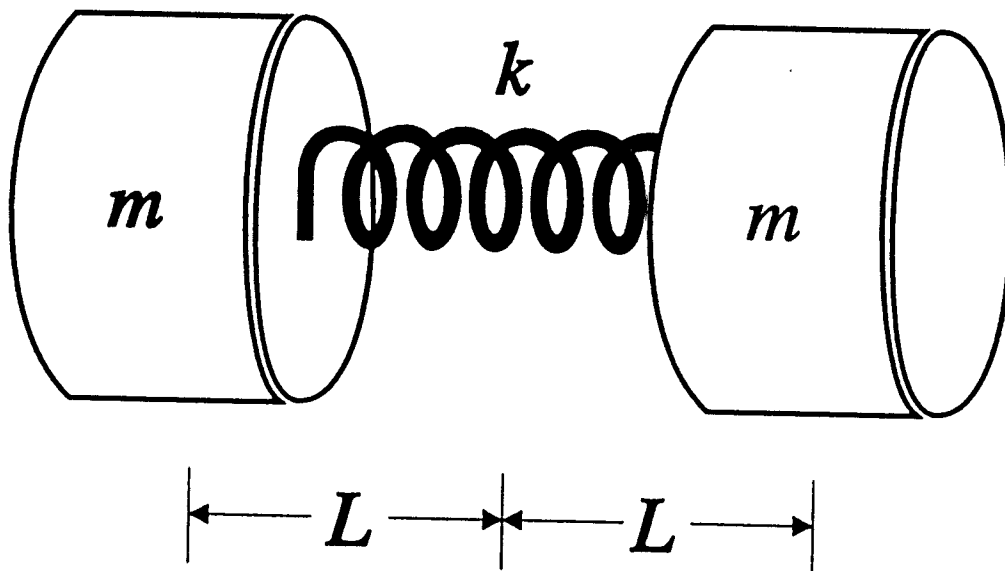

# Gravitational Waves

## *Resonant Bar Detection*

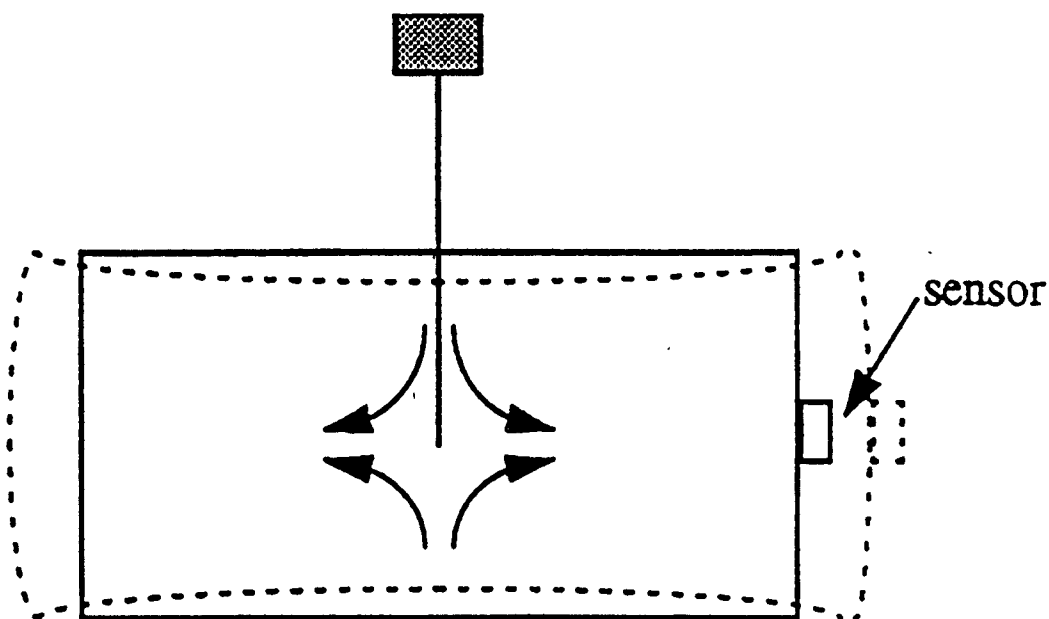

- Bar detector

Group	Antenna	Transducer	Sensitivity ( $h$ )
CERN/Rome	Al5056, 2.3ton, 2.6K	Capacitive+SQUID	$7 \times 10^{-19}$
CERN	Al5056, 2.3ton, 0.1K	Capacitive+SQUID	$2 \times 10^{-18}$
LSU(USA)	Al5056, 1.1ton, 4.2K	Inductive+SQUID	$7 \times 10^{-19}$
Stanford	Al6061, 4.8ton, 4.2K	Inductive+SQUID	$10^{-18}$
UWA(Australia)	Nb, 1.5ton, 5K	RF cavity	$9 \times 10^{-19}$
ICRR(Japan)	Al5056, 1.7ton, 300K	Laser Transducer	—
KEK(Japan)	Al5056, 1.2ton, 4.2K	Capacitive+FET	$4 \times 10^{-22}$ (60Hz)

- Status of bar detectors





# Gravitational Waves

## *International Effort*

---

- Techniques
  - » Resonant Bar Detectors (LSU, Rome, etc)
    - narrow band
  - » Large Scale Interferometers
    - broad band
  
- International Interferometer Effort
  - » U.S. -- LIGO (Two Sites)
    - Caltech & MIT (Wash and Louisiana)
  - » Europe -- VIRGO (One Site)
    - French and Italian (near Pisa)
  - » Smaller efforts
    - Germany, Japan, Australia
  
- Time Scale (Interferometers)
  - » Approximately year 2000

# SCHEMATIC INTERFEROMETRIC DETECTOR

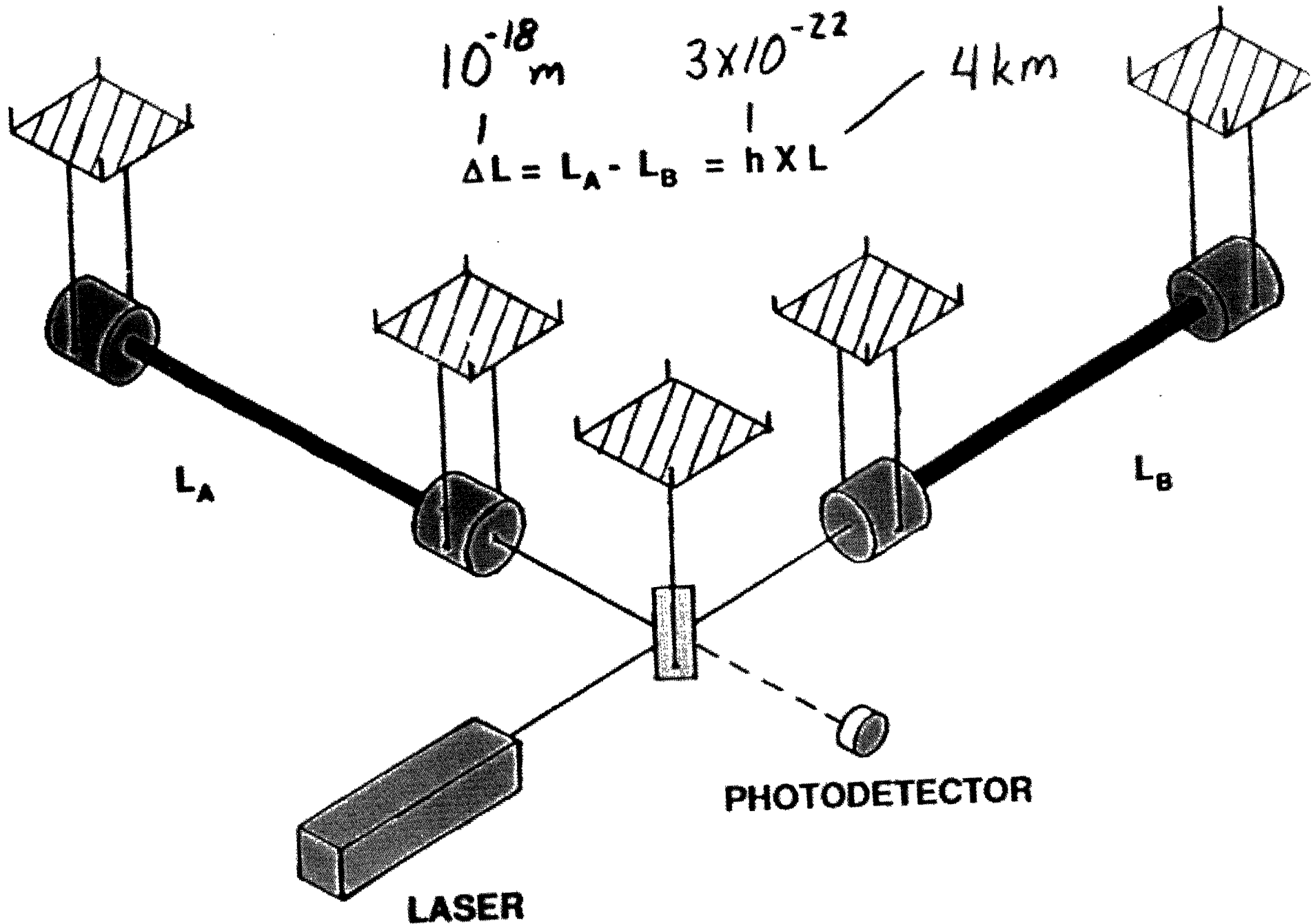

# LIGO

## *Achieving $10^{-18}$ m Sensitivity*

---

### How is it possible????

- Air molecules:

Buffer mirrors

Buffer light beam  
(fluctuating dispersion)

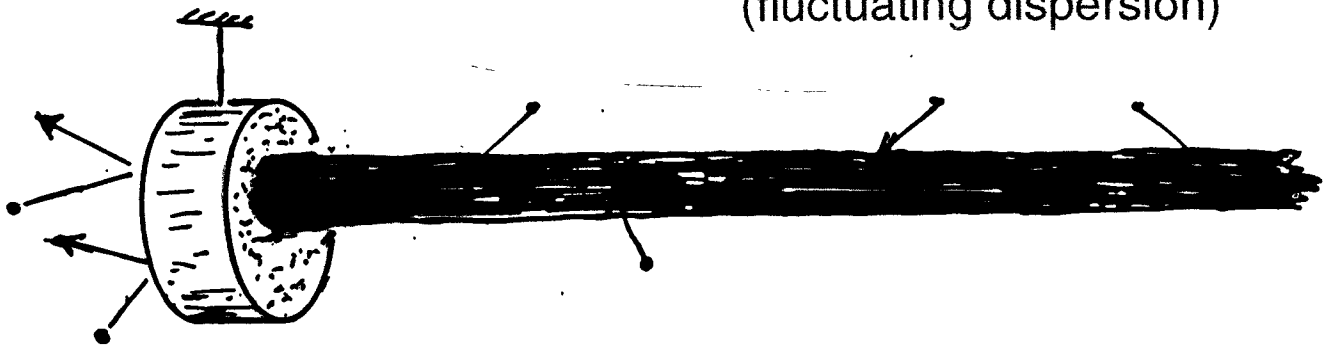

» Mirrors and light beam must be in vacuum

- Mirror's atoms vibrate (thermal noise)

» light beam feels  $10^{18}$  atoms

» atoms vibrate fast:  $\sim 10^{13}$  Hz

» beam measures slow variables:  $\sim 100$  Hz

- Earth vibrates and shakes mirrors

» anti-vibration suspension

» quiet environment

# Noise Budget For First LIGO Detectors

- 5 Watt Laser
- Mirror Losses 50 ppm
- Recycling Factor of 30
- 10 kg Test Masses
- Suspension  $Q=10^7$

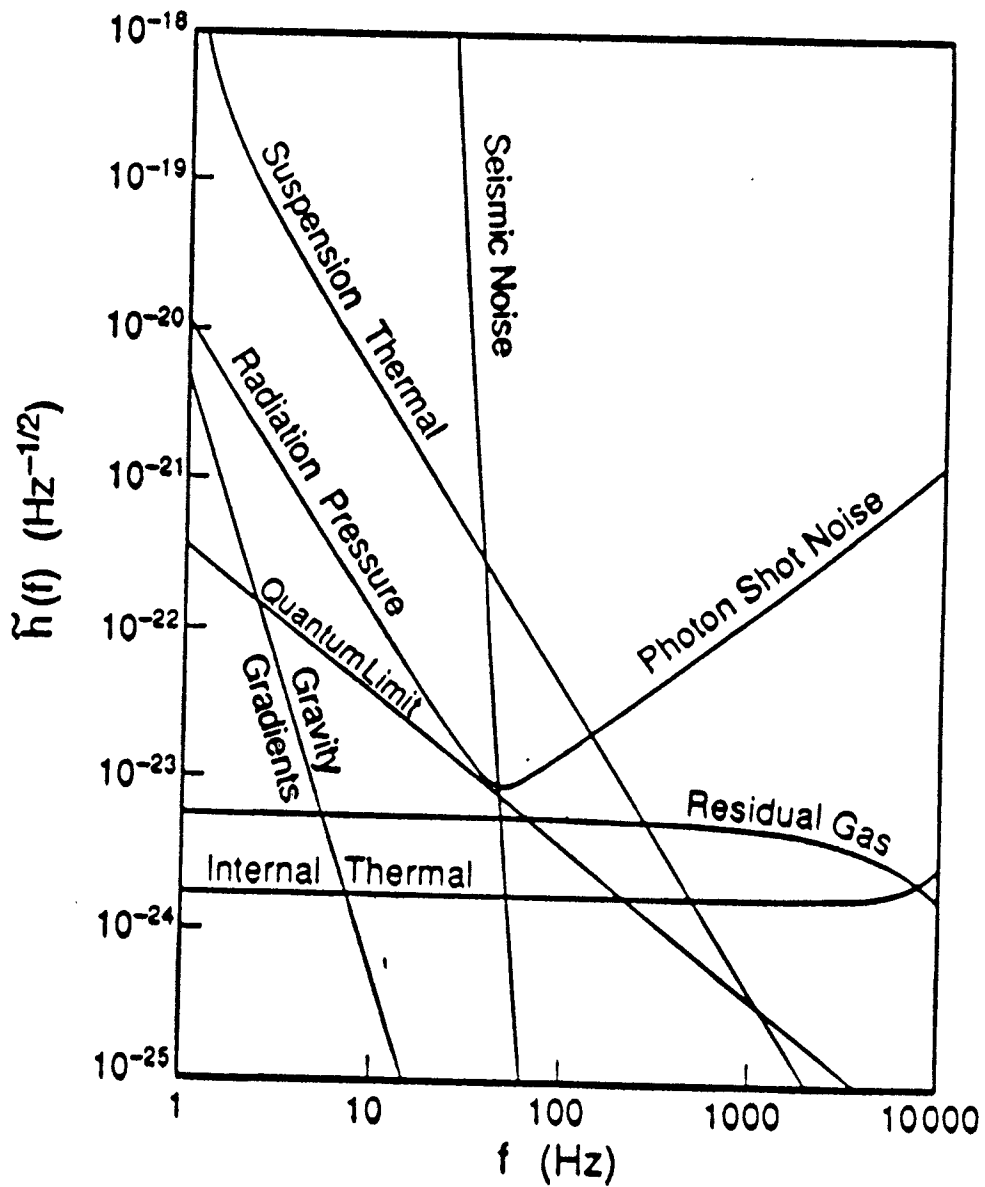

# LIGO

## *Scientific Mission*

---

- Direct Detection of Gravitational Waves
  - Benchmark Source: Neutron Binary Coalescence
    - Detect the last 15 minutes of Hulse/Taylor type binary system (eg. 100 million years)
    - Sensitivity -- detection rate >3 year
  - Other Sources
- Fundamental Physics (GR)
  - » Test General Relativity in Strong Field and High Velocity Limit
  - » Measure Polarization and Propagation Speed

# Neutron Star Binary Coalescence

---

<b><u>Method</u></b>	<b><u>Our Galaxy</u></b>	<b><u>Distance for 3/yr</u></b>
<b>Progenitor Death Rate</b>	<b><math>\sim 1/1000</math> yr</b>	<b>130 M.L.yr</b>
<b>Binary Pulsar Searches and Discoveries</b>	<b><math>\sim 1/10^{5\pm 1}</math> yr</b>	<b>600 M.L.yr.</b>
<b>Ultra-conservative Limit from Binary Pulsar Searches</b>	<b><math>\sim 1/10^7</math> yr</b>	<b>3000 M.L.yr</b>

# Neutron Binary Systems

## *Inspiral*

- LIGO frequency band
  - » last 15 minutes ( $\sim 10^4$  cycles)
- 'Chirp Signal'
- Detailed waveform gives masses, spins, distance, eccentricity of orbit, etc

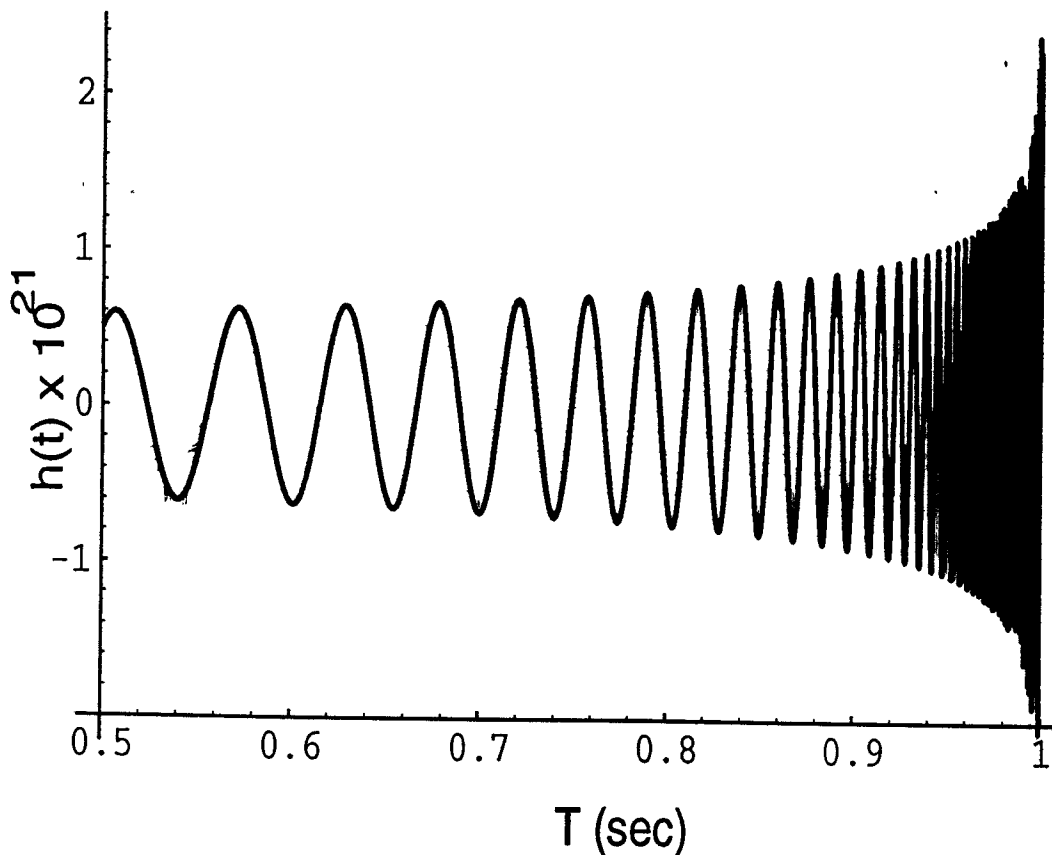

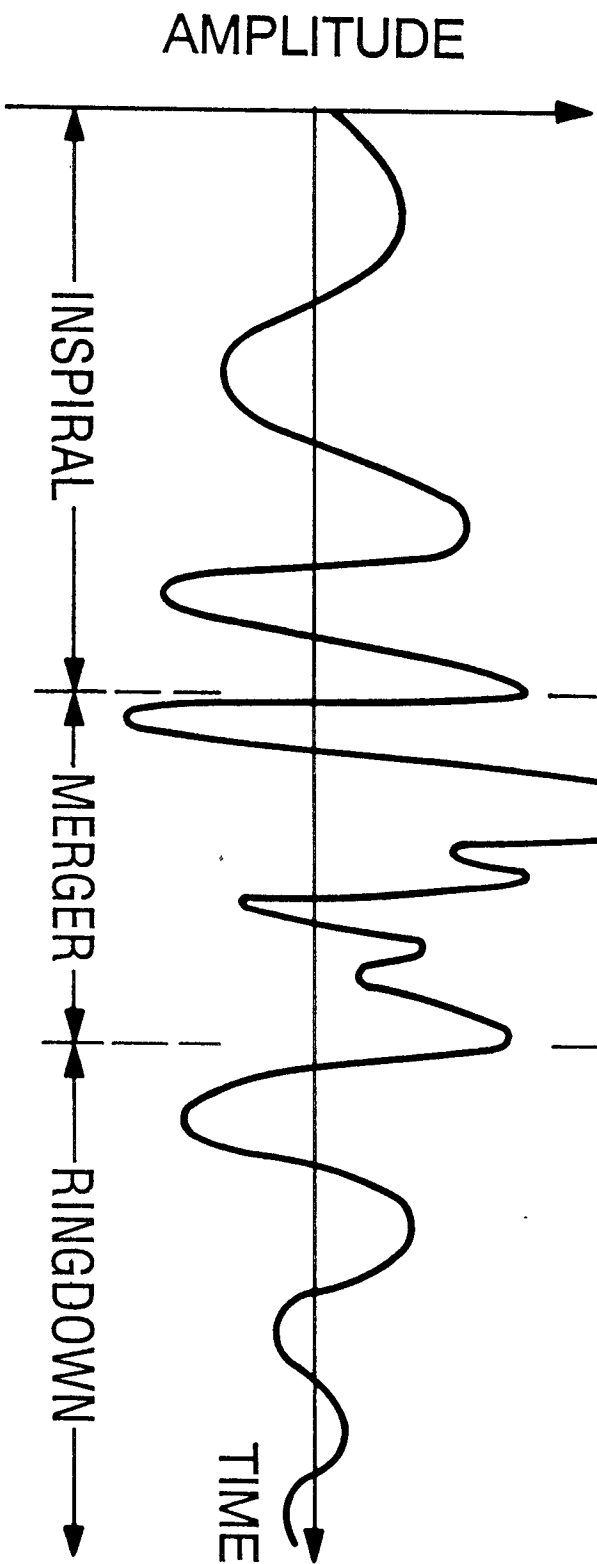
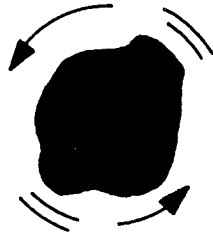
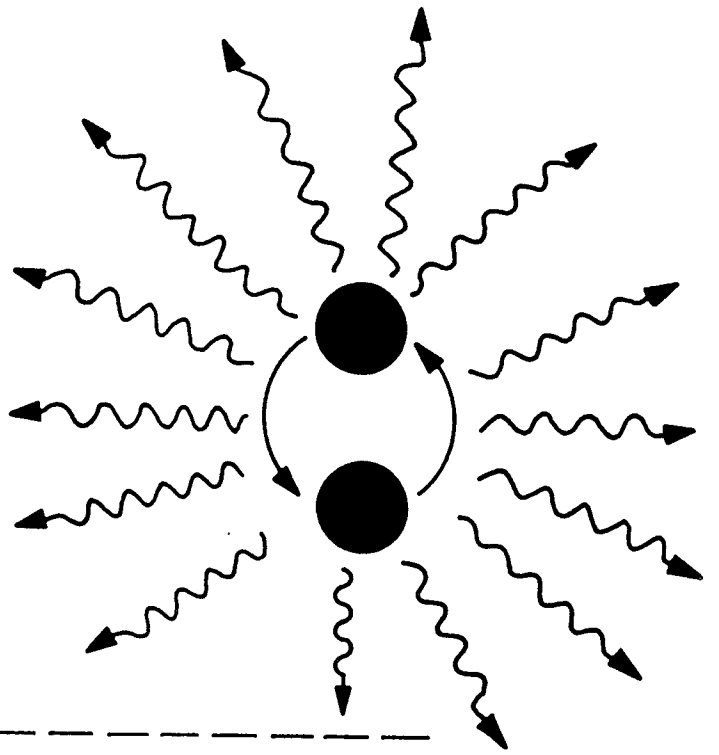
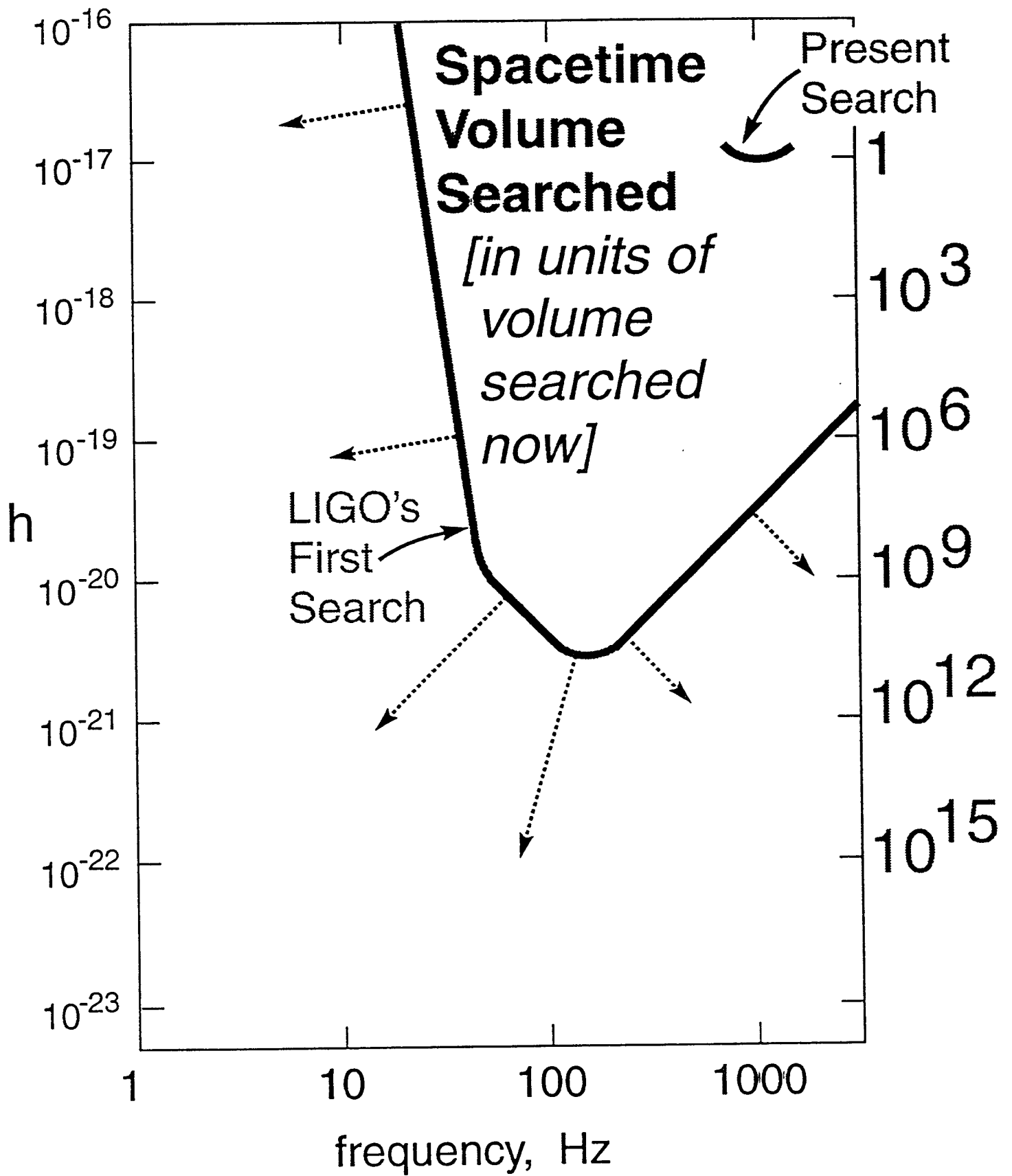

FIG 1





# LIGO

## *Long Range Goals*

---

- Final Coalescence of Binary Systems

- » Neutron Star/Neutron Star
  - Design Benchmark: last 15 min  
20,000 cycles  
600 MLyr
- » Black-hole/Black-hole
- » Black-hole/Neutron Star

- Supernovae

- » Axisymmetric in our galaxy
- » Non-axisymmetric ~300MLyr

- Early Universe

- » Vibrating Cosmic Strings
- » Vacuum Phase Transitions
- » Vacuum Fluctuations from Planck Era

- Unknown Sources



# BLACK HOLE BINARIES

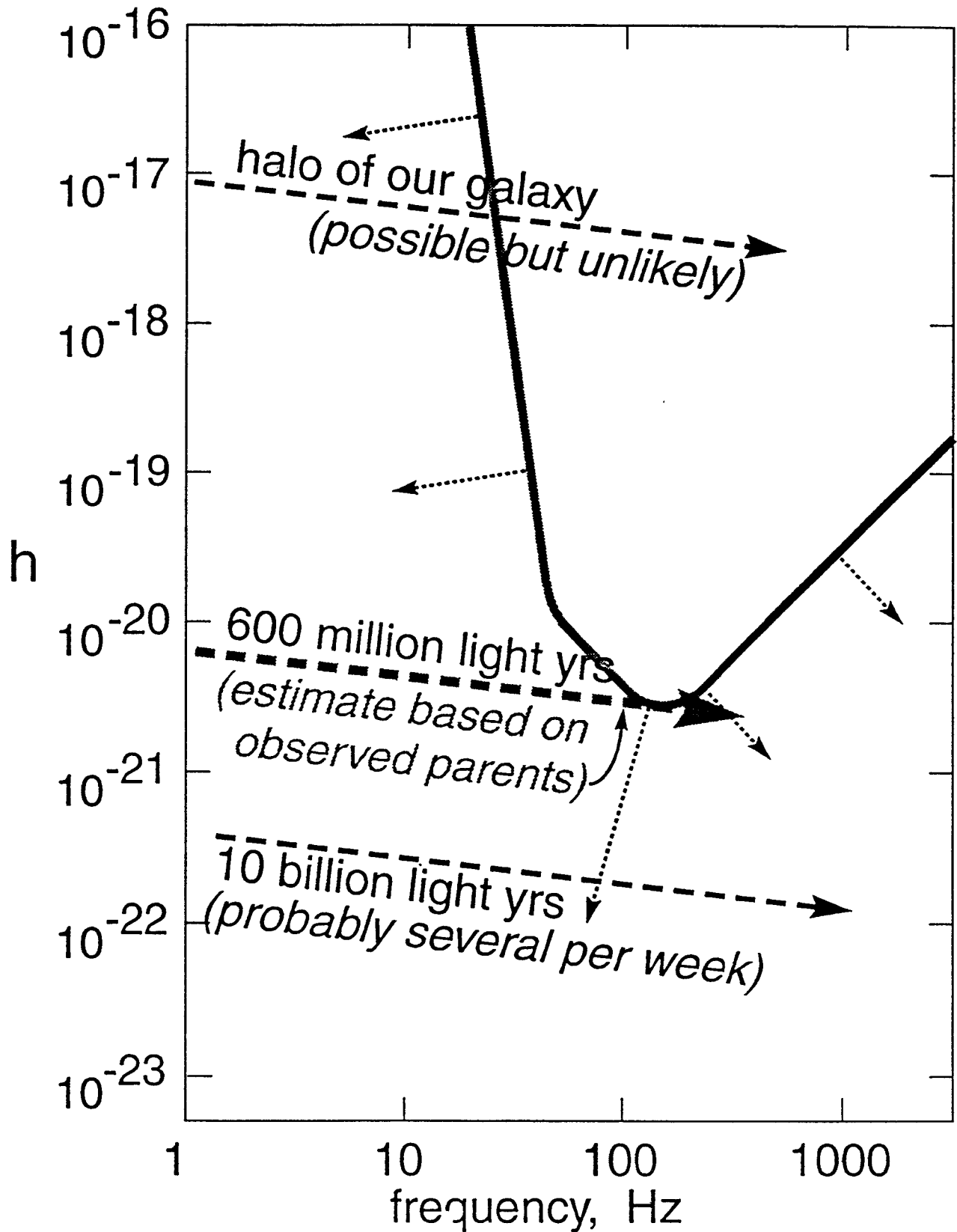
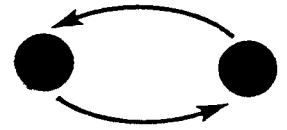

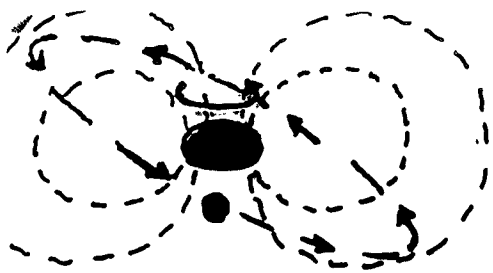

BH Spin  $\rightarrow$  "gravitomagnetic field"  
 (frame dragging)  
 $\rightarrow$   $\sim 20$  precessions of orbit

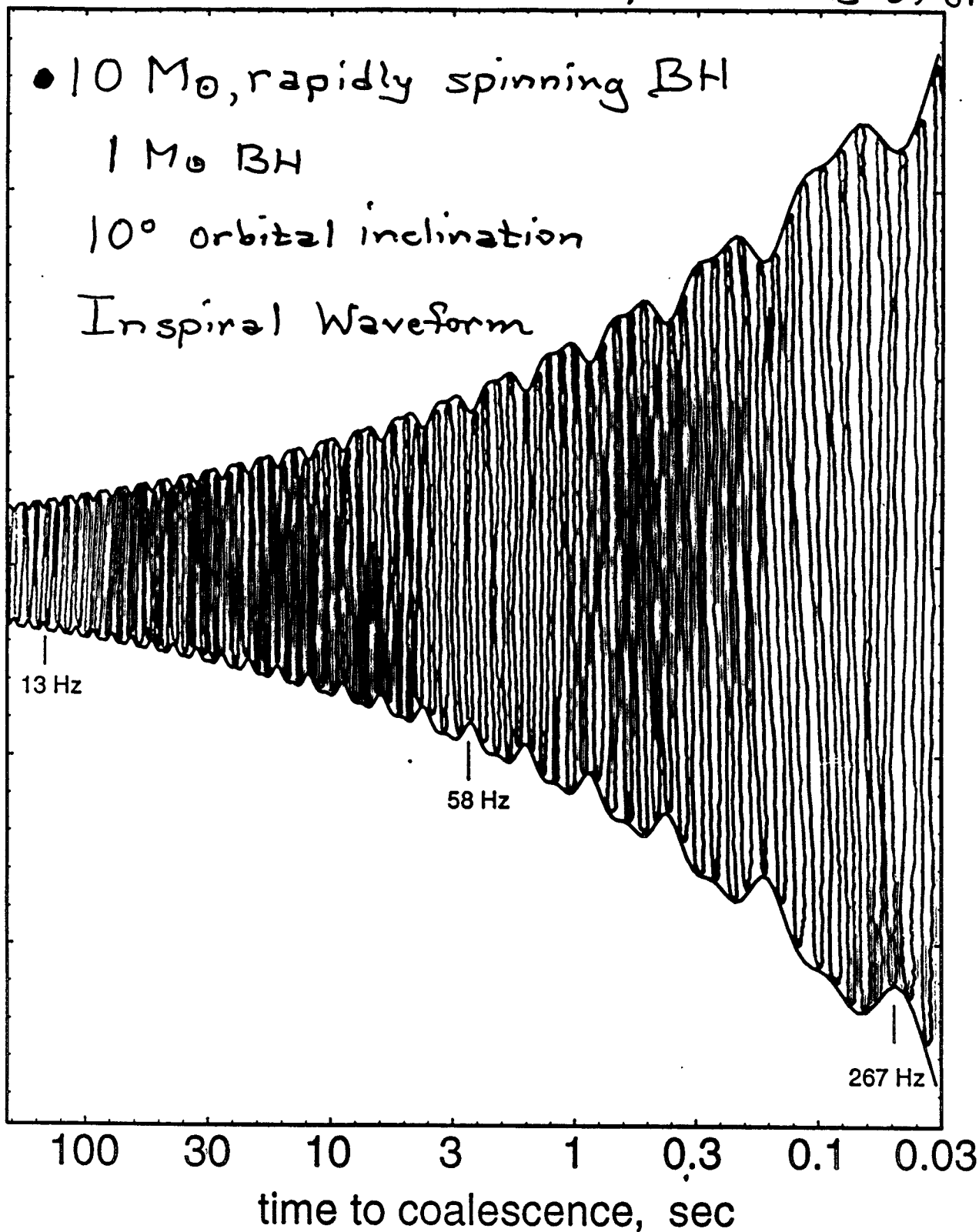

# TWO WAVEFORMS [*Stereophonic*]

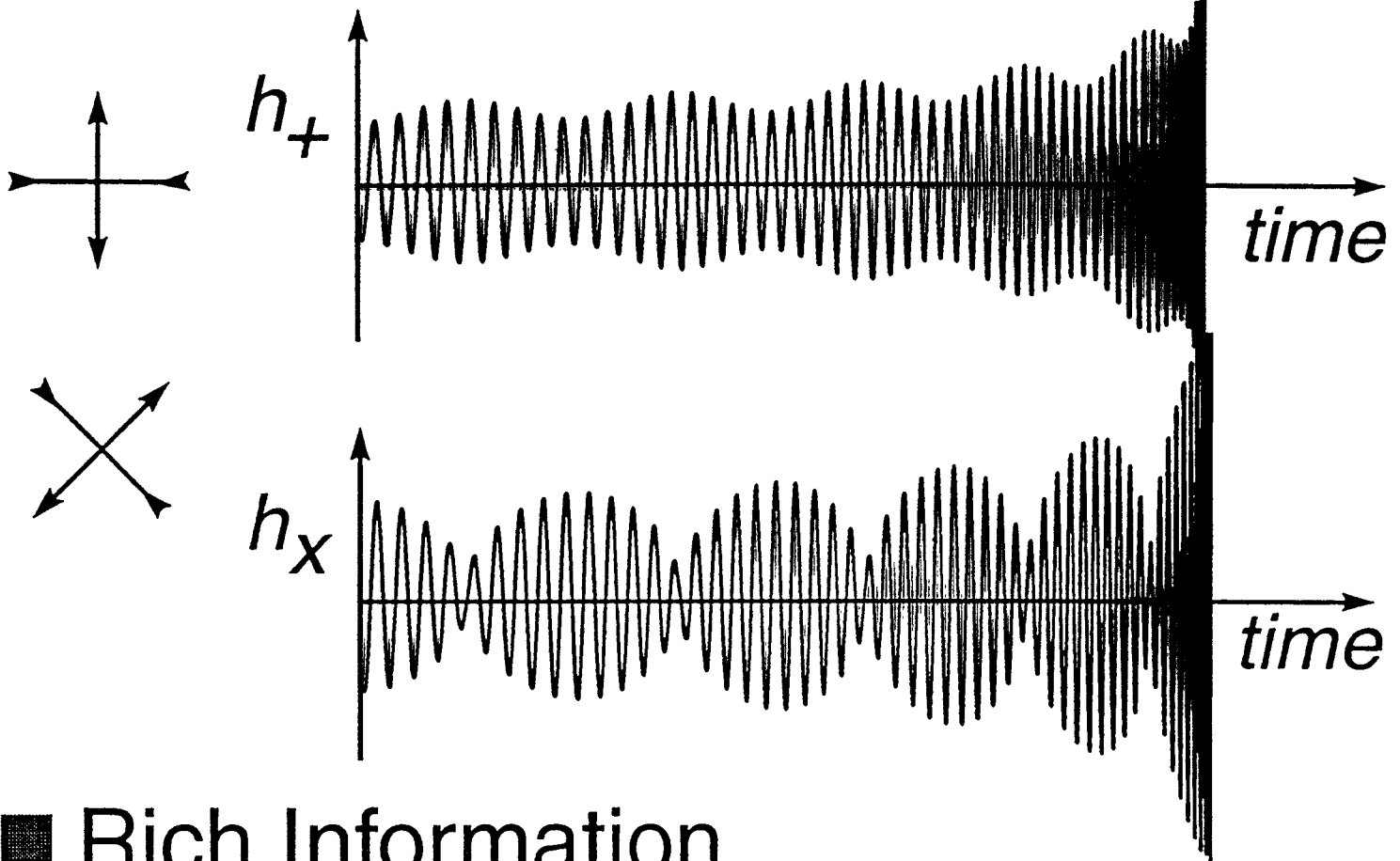

## ■ Rich Information

- *Map of spacetime warpage*

- *Tornado-like swirl of space around big hole*



- *Nonlinear vibrations of spacetime*  
*[Compare with Grand Challenge Supercomputer Simulations]*

# OTHER POSSIBLE SOURCES

SPINNING, "MOUNTAINOUS" NEUTRON STAR

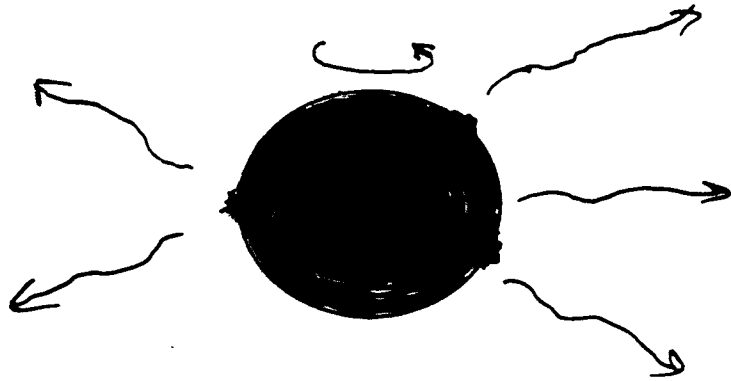

Periodic

IMPLOSION OF A STAR'S CORE

— WHICH TRIGGERS A SUPERNOVA

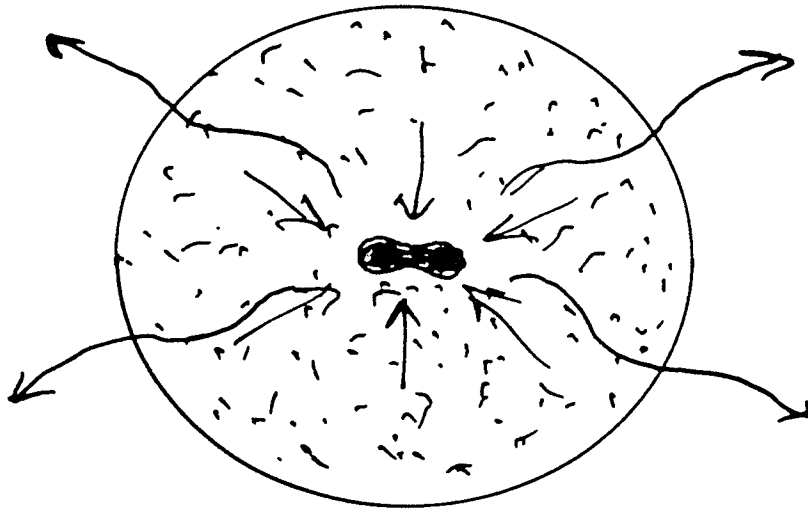

Bursts

VIBRATING LOOPS OF COSMIC STRING

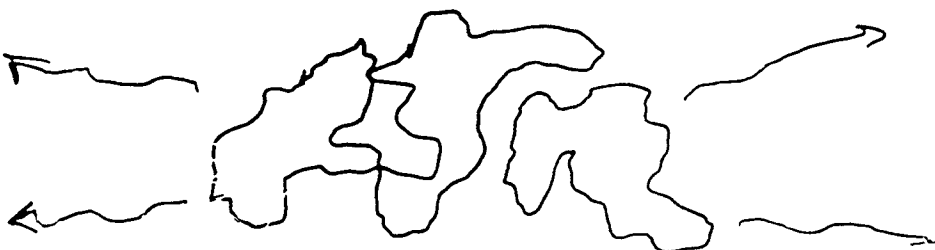

Stochastic

# Pulsars

Light curves

- periodic waveform (integrate for long time)
- rotating non-axisymmetric neutron stars

Simple model:

$$M = 1.4 M_{\odot}$$

$$r = 10 \text{ km}$$

$$I = 10^{45} \text{ gm cm}^2$$

$f$

$$h = \frac{3\pi^2 \epsilon}{R c^4} \approx I f^2$$

$\epsilon$  = equatorial ellipticity

$\rightarrow$

$\rightarrow$   $\frac{1}{2} \epsilon \sin^2 \delta$

Estimate distortion due to dipole magnetic field

$$\epsilon \approx \frac{U_{\text{mag}}}{U_{\text{grav}}} \approx \frac{B^2 R^4}{c^2 M^2} = 10^{-12}$$

if  $B \approx 10^{12}$  gauss (typical of pulsars)

$$\epsilon \approx 3 \cdot 10^{-31} \left( \frac{f}{1 \text{ kHz}} \right)^2 \left( \frac{R}{10 \text{ km}} \right)^4$$

if pulsars born rapidly rotating then several most recent pulsars with such amplitude in our galaxy any time

---

Note fastest known pulsar PSR1937+214 only has  $B \approx 10^8$  gauss, but it is thought this pulsar was 'spun up' by consuming low mass companion  
Also "Wagener star" enhancement.



# Supernovae

Type I - explosive detonation of a white dwarf star (no substantial emission of gravitational waves)

Type II - may emit strong gravitational waves

'naked eye' observations

16<sup>th</sup> century (Tycho)

SN 1987A (neutrinos)

Gravitational radiation (mechanism)

- massive star produces core  $\sim 1.4 M_{\odot}$   
which has burned to iron (white dwarf)
- electron degeneracy pressure no longer can support the core
- matter converts into neutrons
- collapses
- bounce @ nuclear densities ( $\sim 3 \cdot 10^{14} \text{ gm/cm}^3$ )

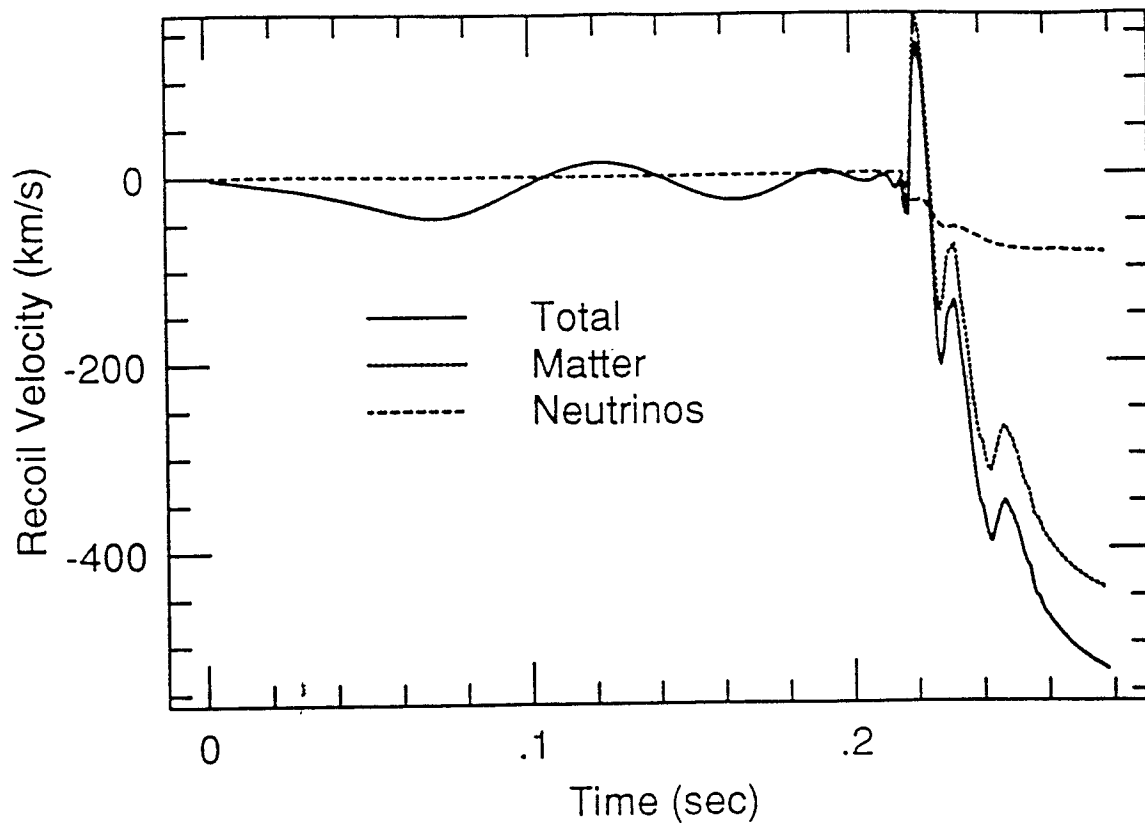

FIG. 2. The inferred recoil speed (in  $\text{km s}^{-1}$ ) imparted to the core versus time (in seconds) for the simulation highlighted in this paper. The initial momentum is approximately zero, but grows systematically after bounce in the direction opposite to the artificial wedge, cut into the core to mimic an asymmetry just before collapse. Shown are the total recoil (solid) and the contributions due to the neutrino emission anisotropy (dashed) and the ejecta motions (dotted).

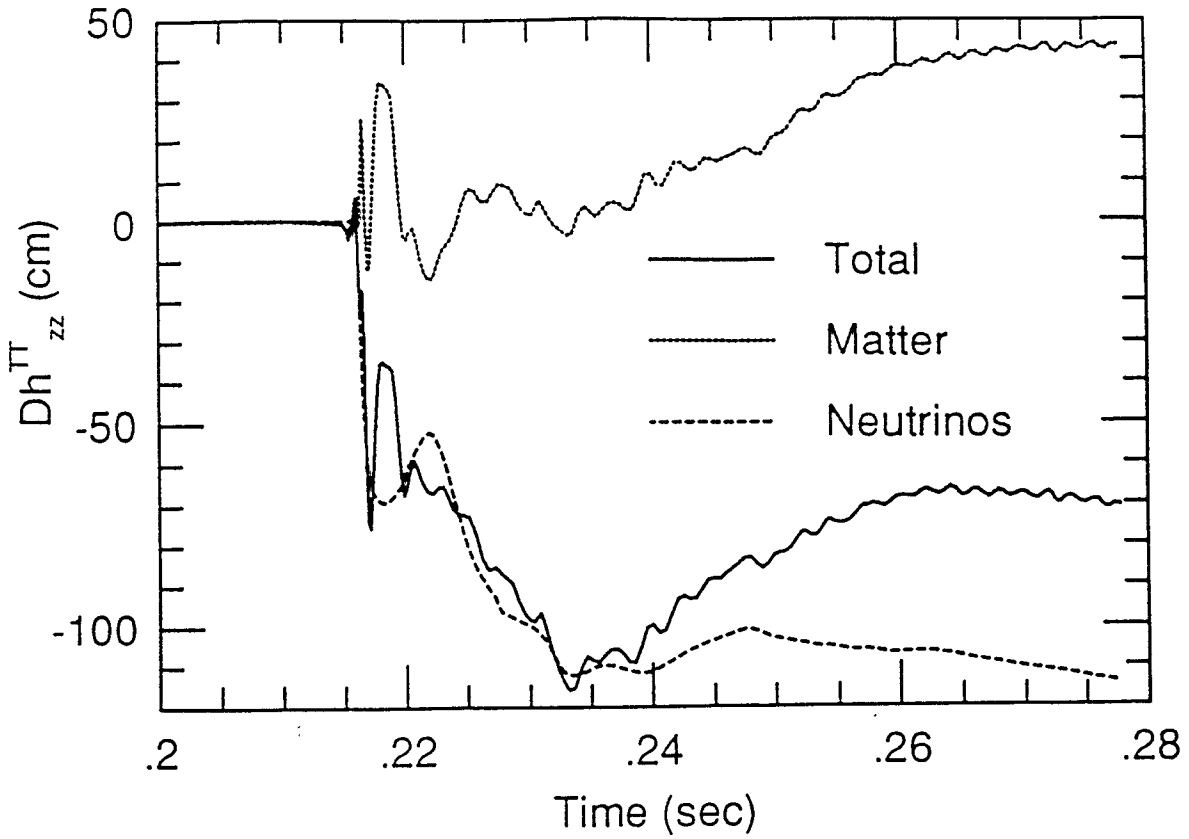

FIG. 3. The gravitational wave strain,  $h_{zz}^{TT}$ , times the distance to the supernova,  $D$ , versus time (in seconds). Core bounce is at 0.215 seconds. The total, matter, and neutrino waveforms are rendered with the solid, dotted, and dashed lines, respectively.

• physics modeling very difficult  
(departure from spherical shape)

• guidance (unclear)

- supercomputers assume spherical sym.

- 2D models (Burrows)

- Crab pulsar  $f_{rot} \approx 30.3 \text{ Hz}$

$$J = 2 \cdot 10^{47} \text{ erg-sec}$$

(Saenz-Shapiro  $\rightarrow$  radiate gravitational  
 $3 \cdot 10^{-6}$  of rest mass

$$h \approx 10^{-23} \text{ @ VIRGO}$$

- collapsing cores w/ high angular momentum?  
(eg "millisecond pulsars")

## FIGURES

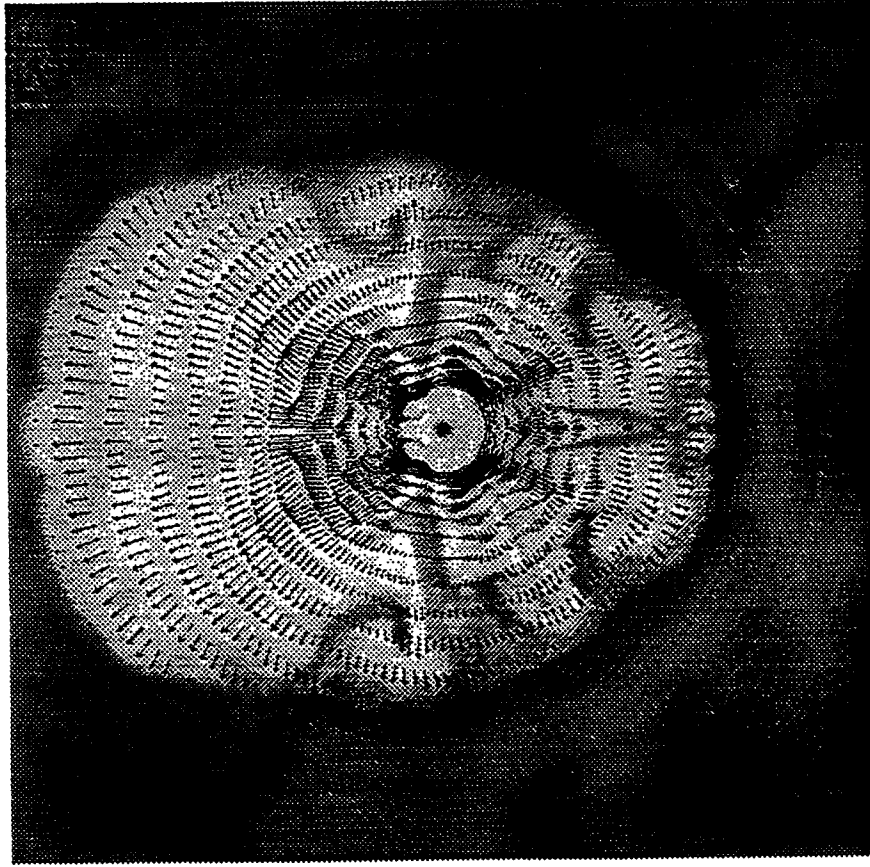

FIG. 1. A grey-scale rendering of the entropy distribution at the end of the simulation, about 50 milliseconds into the explosion. Note the pronounced pole-to-pole asymmetry in the ejecta and the velocity field (as depicted with the velocity vectors). The physical scale is 2000 km from the center to the edge. Darker color indicates lower entropy and  $\theta = 0$  on the bulge side of the symmetry axis.

# Stochastic Gravity-Wave Background

- could come from early Universe  
LIGO Band  $\sim 10^{-22}$  sec

(also could be overwhelmed by  
more recent sources)

- graviton background analogous to  $\Omega_{em}$   
THERMAL SPECTRUM  $T \sim 2.9$  K

(smaller than Cosmic Microwave  
Background Radiation because in  
conventional hot big bang model,  
gravitons decoupled when temperature  
of Universe dropped below Planck temp)

# THE BIG BANG SINGULARITY

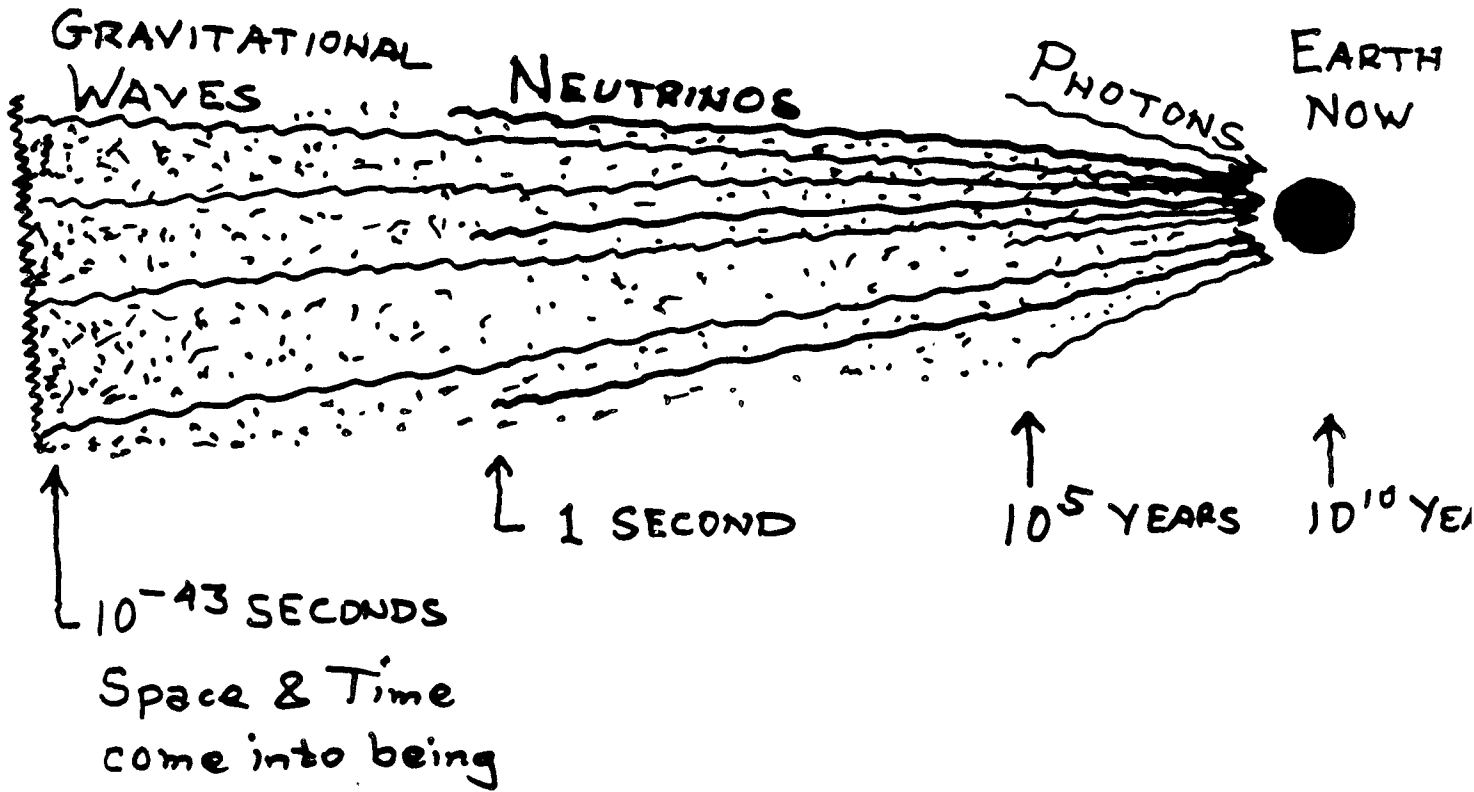

LIGO      10<sup>-22</sup> sec      Temp ~ 10<sup>6</sup> GeV  
 graviton ~ 10 MeV

LISA  
 (10<sup>-22</sup> Hz)      10<sup>-4</sup> sec      Temp ~ 10<sup>2</sup> GeV (electroweak)  
 graviton ~ 1 keV

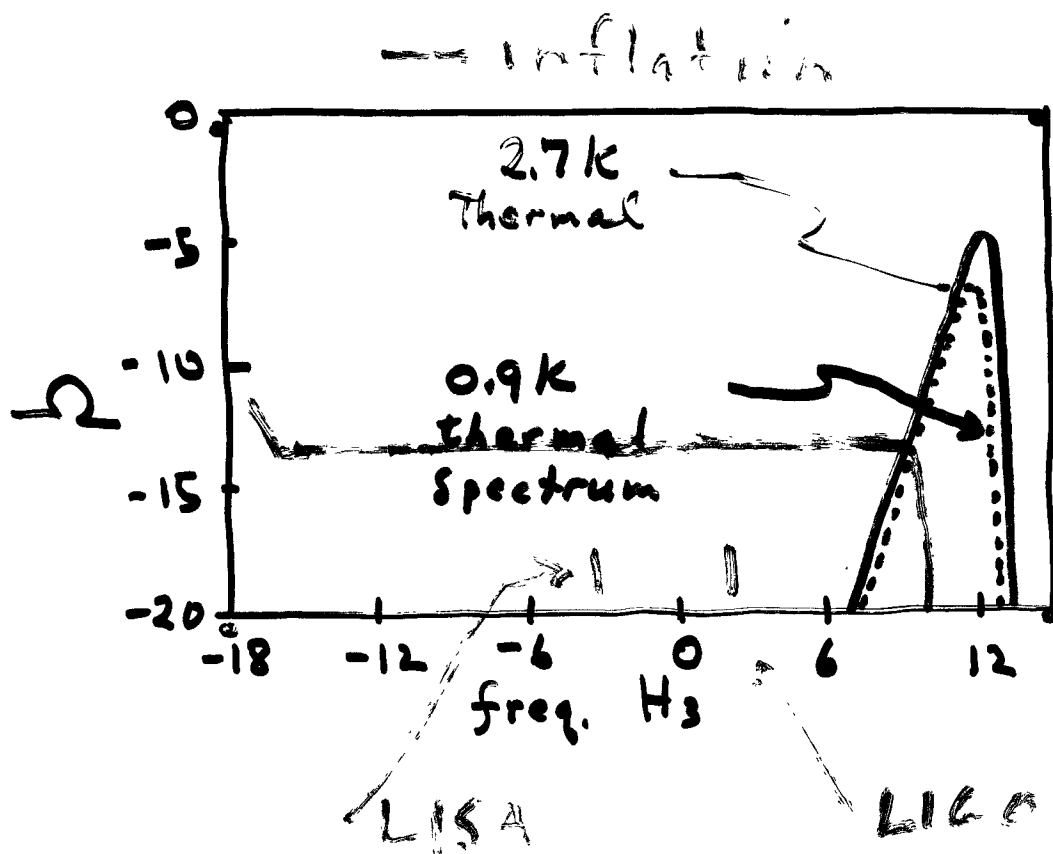

• unlikely equilibrium was established  
 since gravitational interactions so weak  
 (time required longer than expansion time)

• useful benchmark

• detection

correlate (anticorrelate) signals  
 from different detectors

(eg  $<64 \text{ Hz}$  LIGO detectors correlated)



# How to detect Stochastic Background

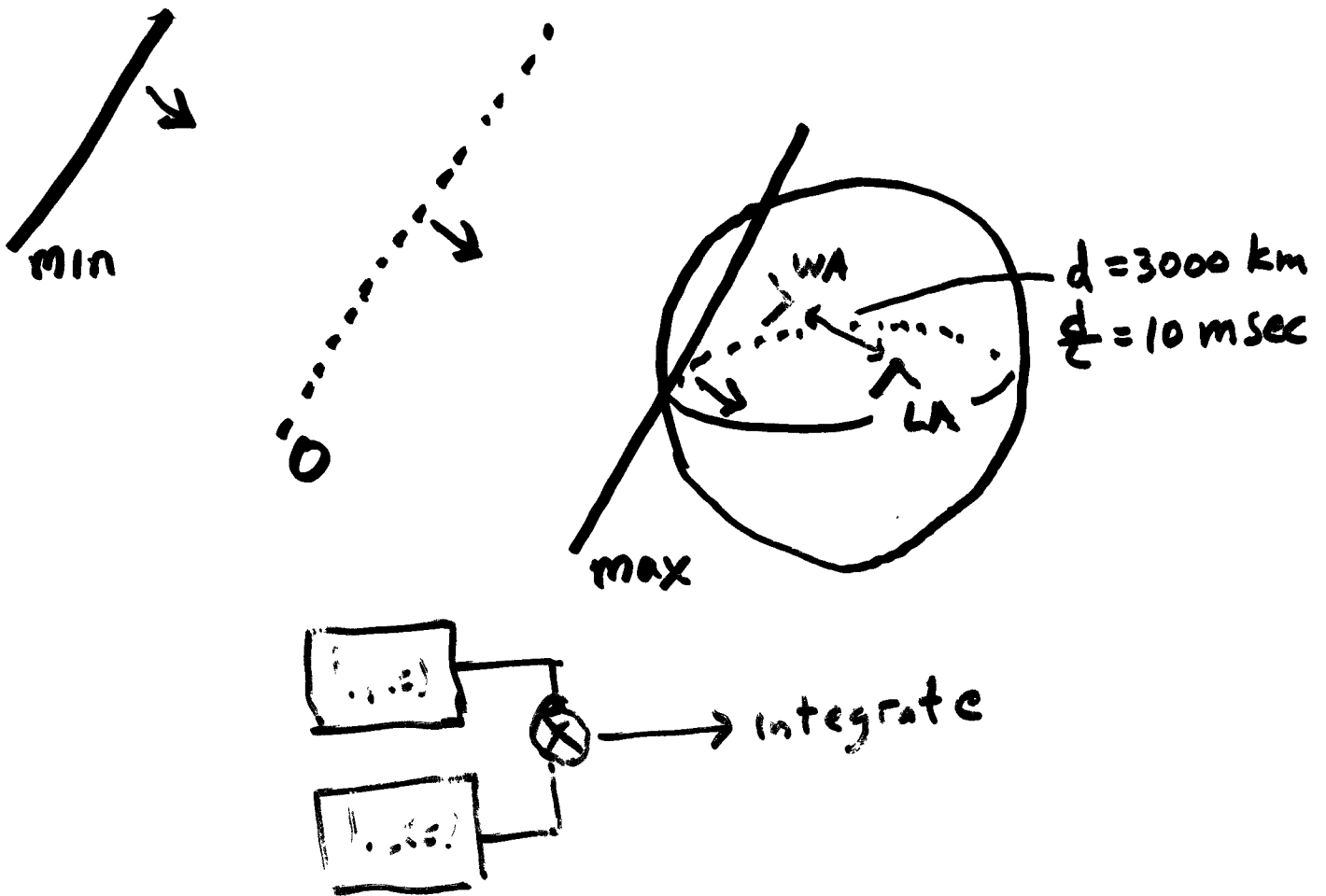

Gravitational waves with  $\frac{\lambda}{2} > 3000 \text{ km}$  ( $f \lesssim 50 \text{ Hz}$ )  
 detector arms move in phase (together) so  
 average product  $\langle h_1(t) h_2(t) \rangle > 0$

In absence of background (and other signal)  
 average product  $\langle h_1(t) h_2(t) \rangle \rightarrow 0$

Michelson, Mon. Not. Roy. Astron Soc 227 (1987) 933.  
 Christensen, Phys. Rev. D46 (1992) 5250.  
 Flanagan, Phys. Rev. D48 (1993) 2389

# LIGO

## Sensitivity

- Comparison of sensitivity and wave strengths ( $h_{sb} = 11h_{rms}$ )

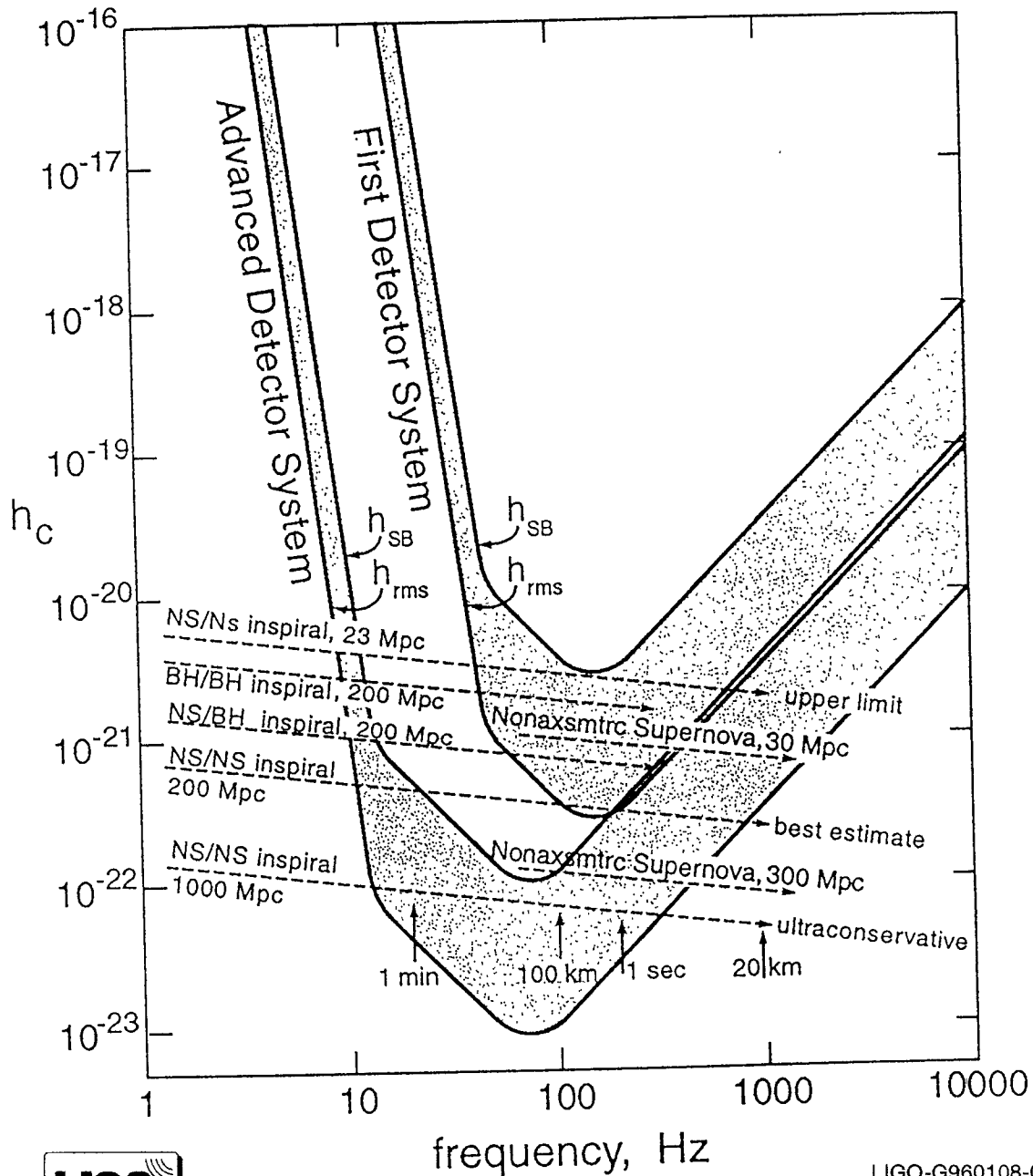

# LIGO INTERFEROMETERS

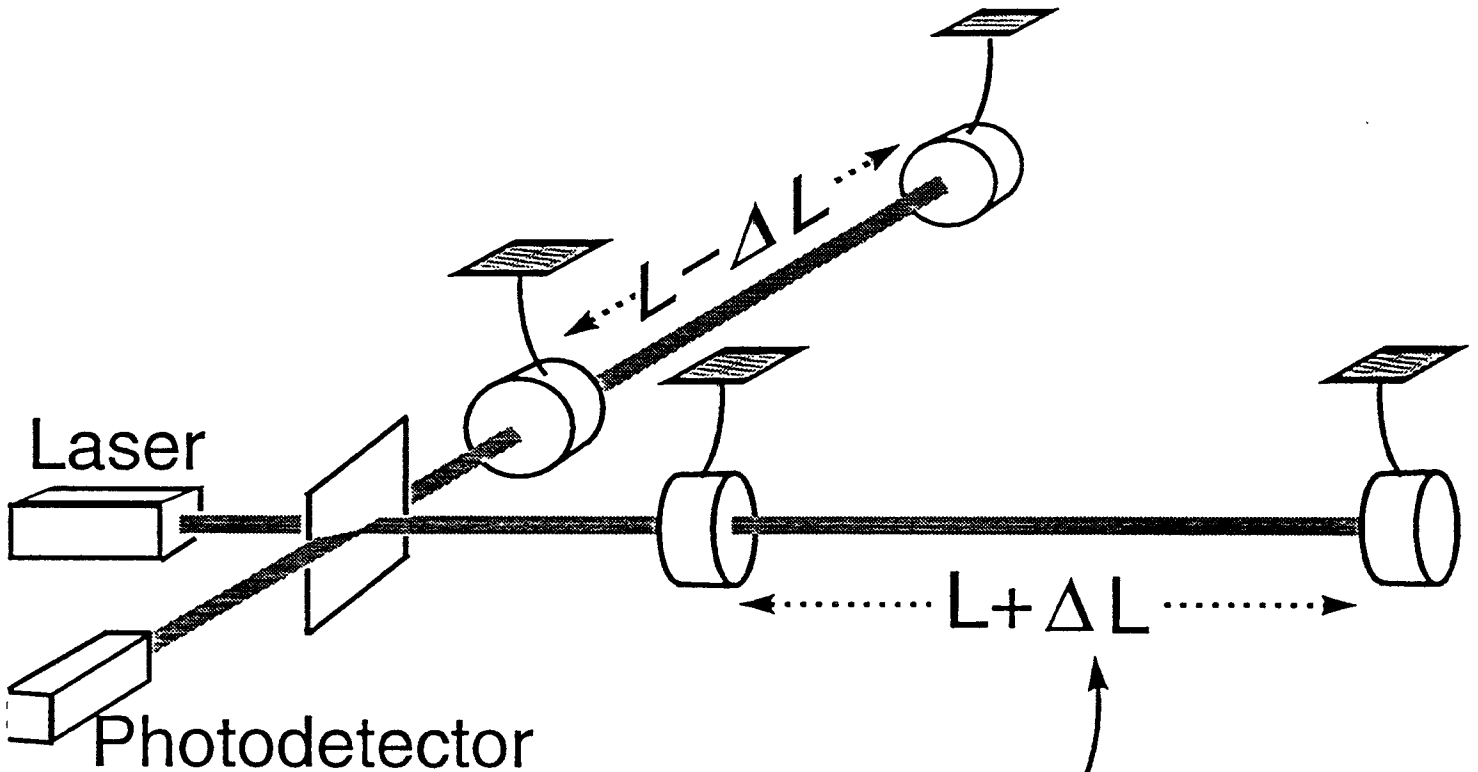

- To make  $\Delta L$  large enough for detection requires  $L \gtrsim 4 \text{ km}$

$$\Delta L = hL = 4 \times 10^{-16} \text{ cm}$$

$10^{-21}$        $4 \text{ km}$

- Measured waveform,  $h(\text{time}) = \Delta L/L$ , is a linear combination of  $h_+$  and  $h_x$ , which depends on interferometer's orientation

# LIGO

## *The Project*

---

- National Science Foundation
- Construction Project (1995-1999)
  - » Facilities and Initial Detector
- Commission Facility (1999-2001)
  - » Implement Initial Detectors
    - $h \sim 10^{-20}$  - Coincidence
      - Initial Search (end of 2000)
    - $h \sim 10^{-21}$  - Initial Design Sensitivity (end 2001)
- Full Operations (2002 + ... )
  - » Data Dating/Analysis
    - data collaboration with VIRGO
  - » Enhance Initial Detector
    - incorporate outside collaborations
  - » Advanced Detectors
    - Syracuse, Colorado, Stanford, etc
    - Caltech/MIT efforts



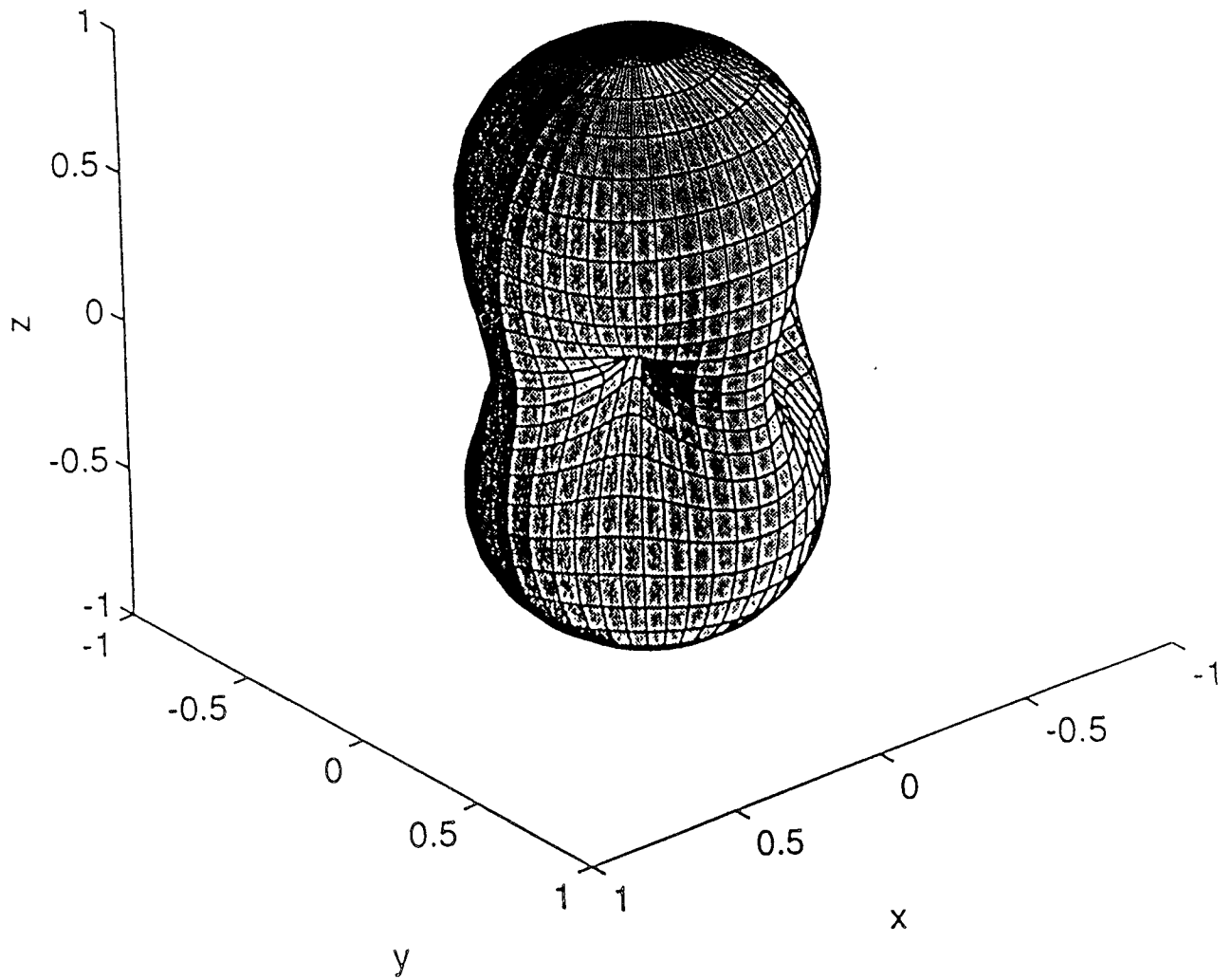
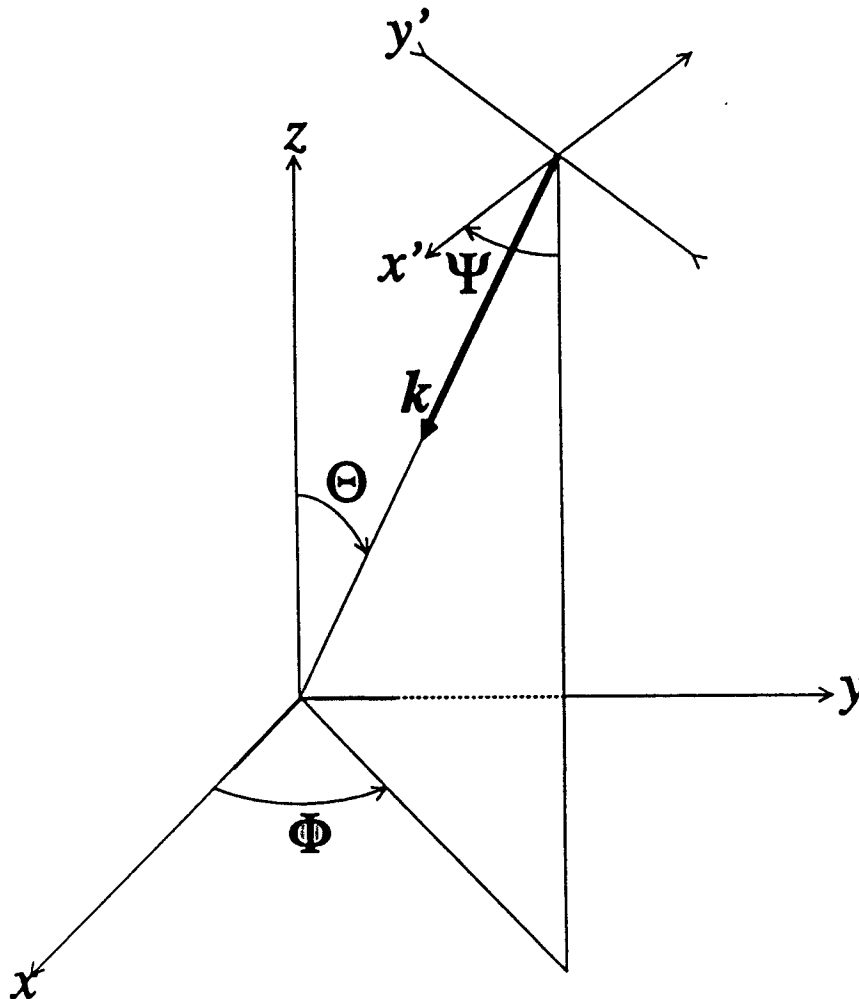
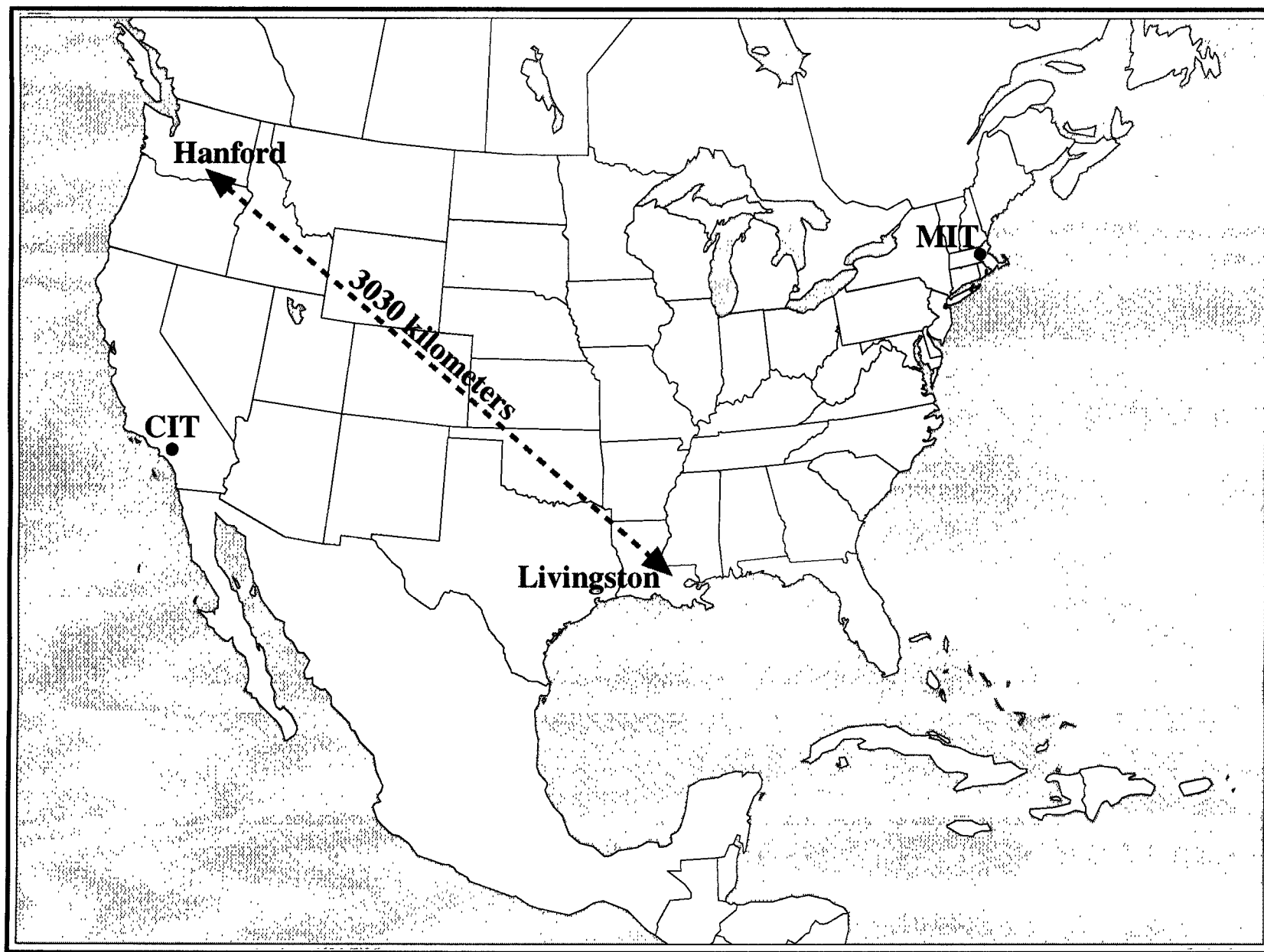

Figure 2.7 The sensitivity, as a function of direction, of an interferometric gravitational wave detector to unpolarized gravitational waves. The interferometer arms are oriented along the x and y axes.

# Gravitational Wave Detector

- Antenna Pattern
  - » coordinate system





# Interferometers

- $\Delta L/L = h = F_+ h_+(t) + F_x h_x(t)$

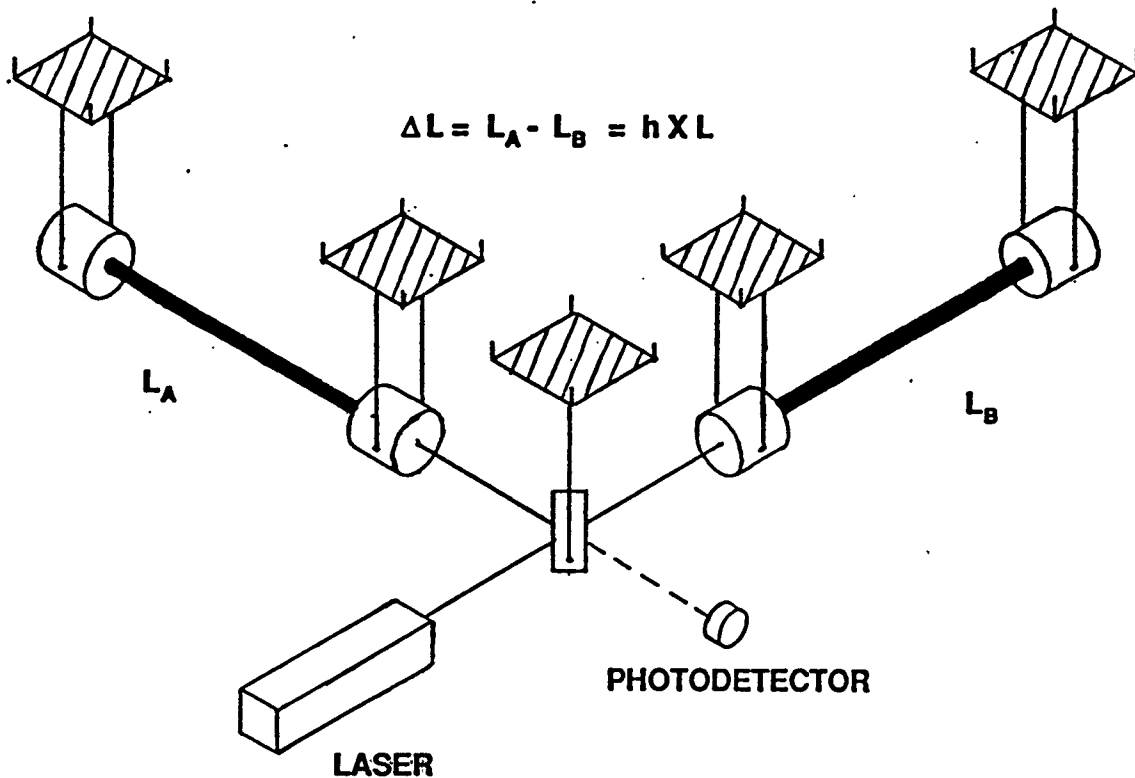

- LIGO Measures one waveform
  - » orientation aligned (Washington & Louisiana)
  - » direction(timing) determined  $\sim 10'$  to  $\sim 1^0$  on ring
- LIGO + VIRGO(Italy)
  - » decompose waveforms ( $h_+(t), h_x(t)$ )
  - » direction  $10'$  to  $1^0$



# Source Positions

---

- Celestial Sphere position location from LIGO (two interferometers)

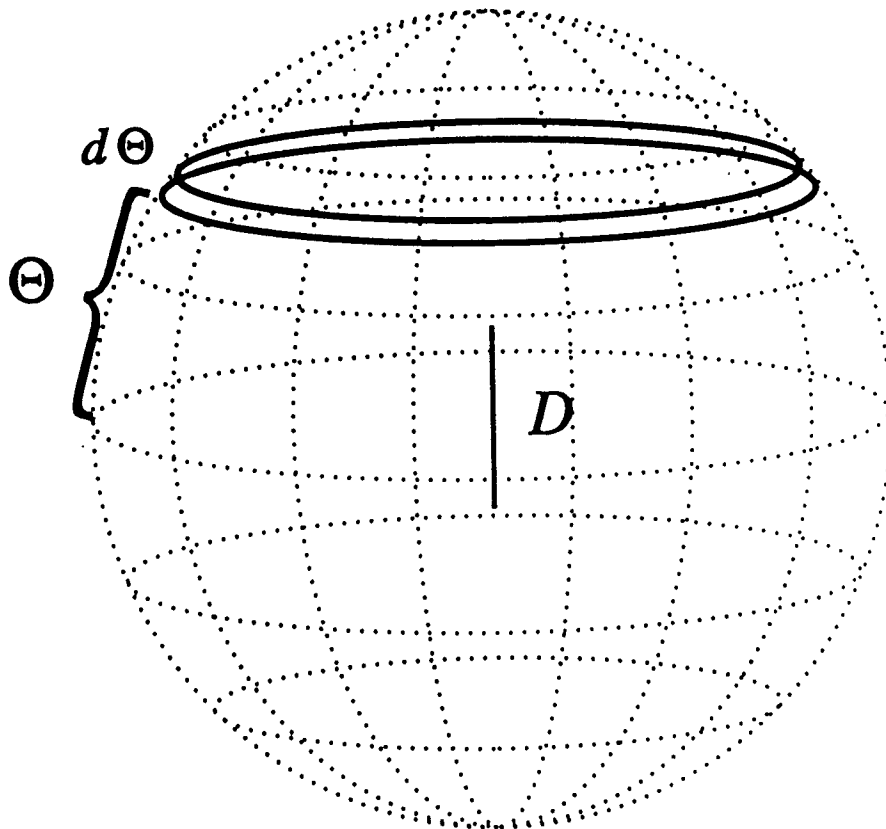

- determine from time shift between detectors ( $\sim .1$  msec accuracy)
- 'declination angle' of circle (ring)

$$\Theta = \arcsin \frac{c\Delta t_{sig}}{D}$$

# Source Positions

## *LIGO + VIRGO*

---

- LIGO (2 det) + VIRGO (1 det)
- decomposition of waveforms
  - »  $h_x(t), h_+(t)$
- position on sky (two positions)

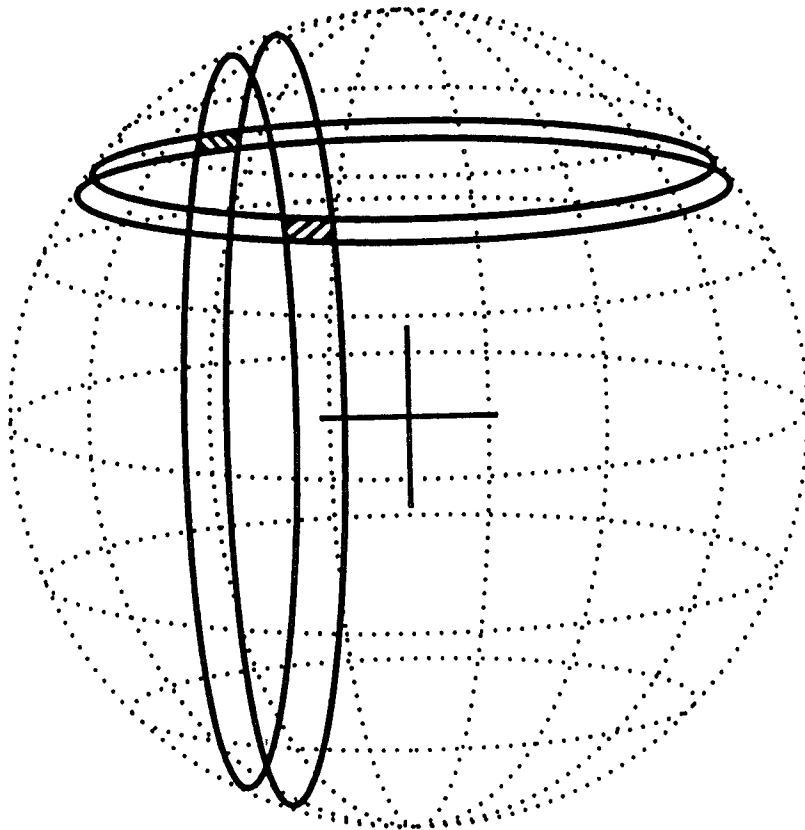

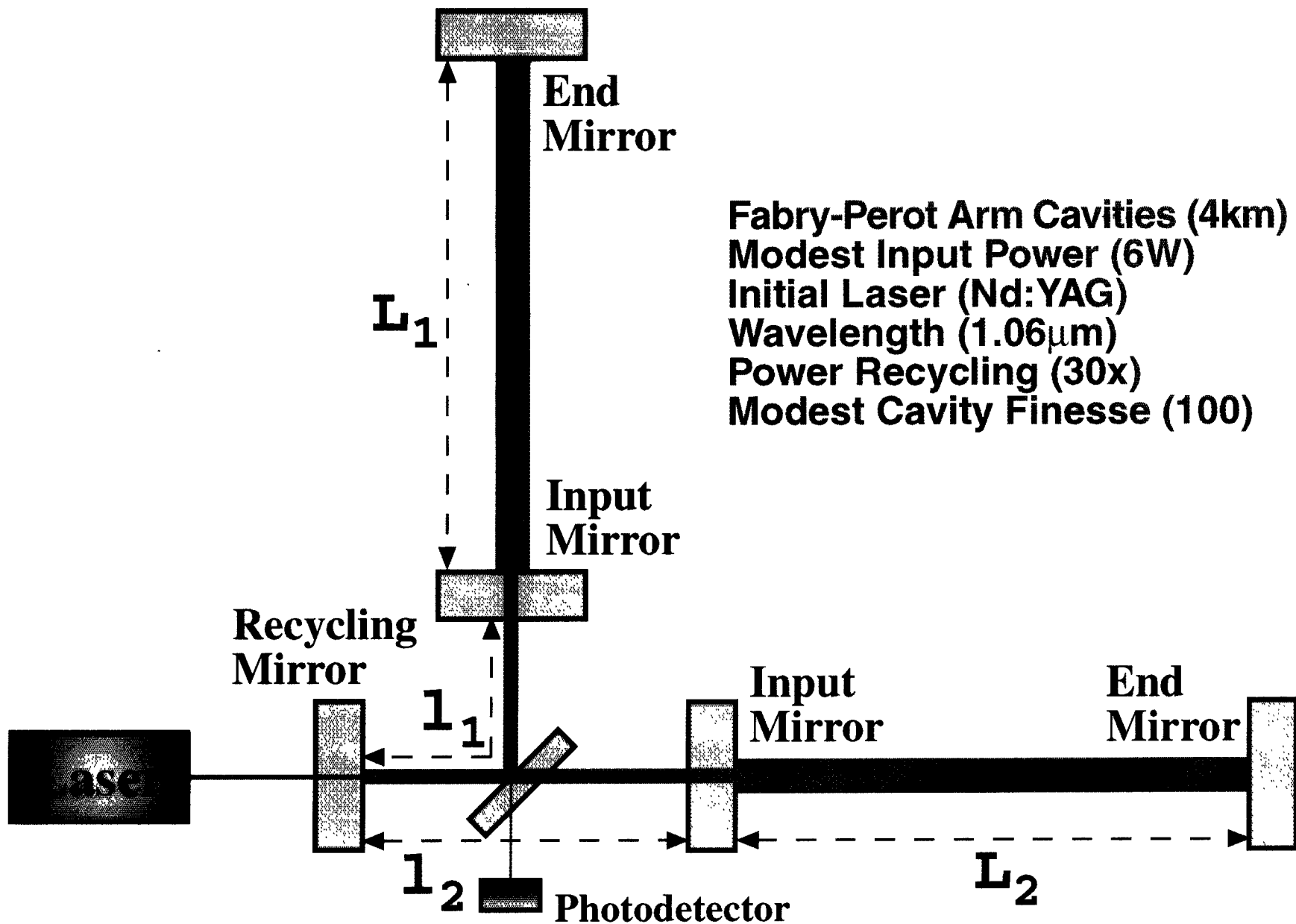

# Initial Interferometer Specifications

Strain Sensitivity [rms, 100 Hz band]	$10^{-21}$
Displacement Sensitivity [rms, 100 Hz band]	$4 \times 10^{-18} \text{ m}$
Fabry-Perot Arm Length	$4000 \text{ m}$
Vacuum Level	$< 10^{-6} \text{ torr}$
Laser Wavelength	$1064 \text{ nm}$
Optical Power at Laser Output	$10 \text{ W}$
Optical Power at Interferometer Input	$5 \text{ W}$
Power Recycling Factor	30
Input Mirror Properties	Reflectivity = 0.97
End Mirror Properties	Reflectivity > 0.9998
Arm Cavity Optical Loss	$\leq 3\%$
Light Storage Time in Arms	$1 \text{ ms}$
Test Masses	Fused Silica, 11 kg
Mirror Diameter	$25 \text{ cm}$
Test Mass Period Pendulum	$1 \text{ sec}$
Seismic Isolation System	Passive, 4 stage
Seismic Isolation System Horizontal Attenuation	$\geq 10^{-7} (100 \text{ Hz})$
Maximum Background Pulse Rate	1 per minute

# Initial Interferometers

## Noise Floor

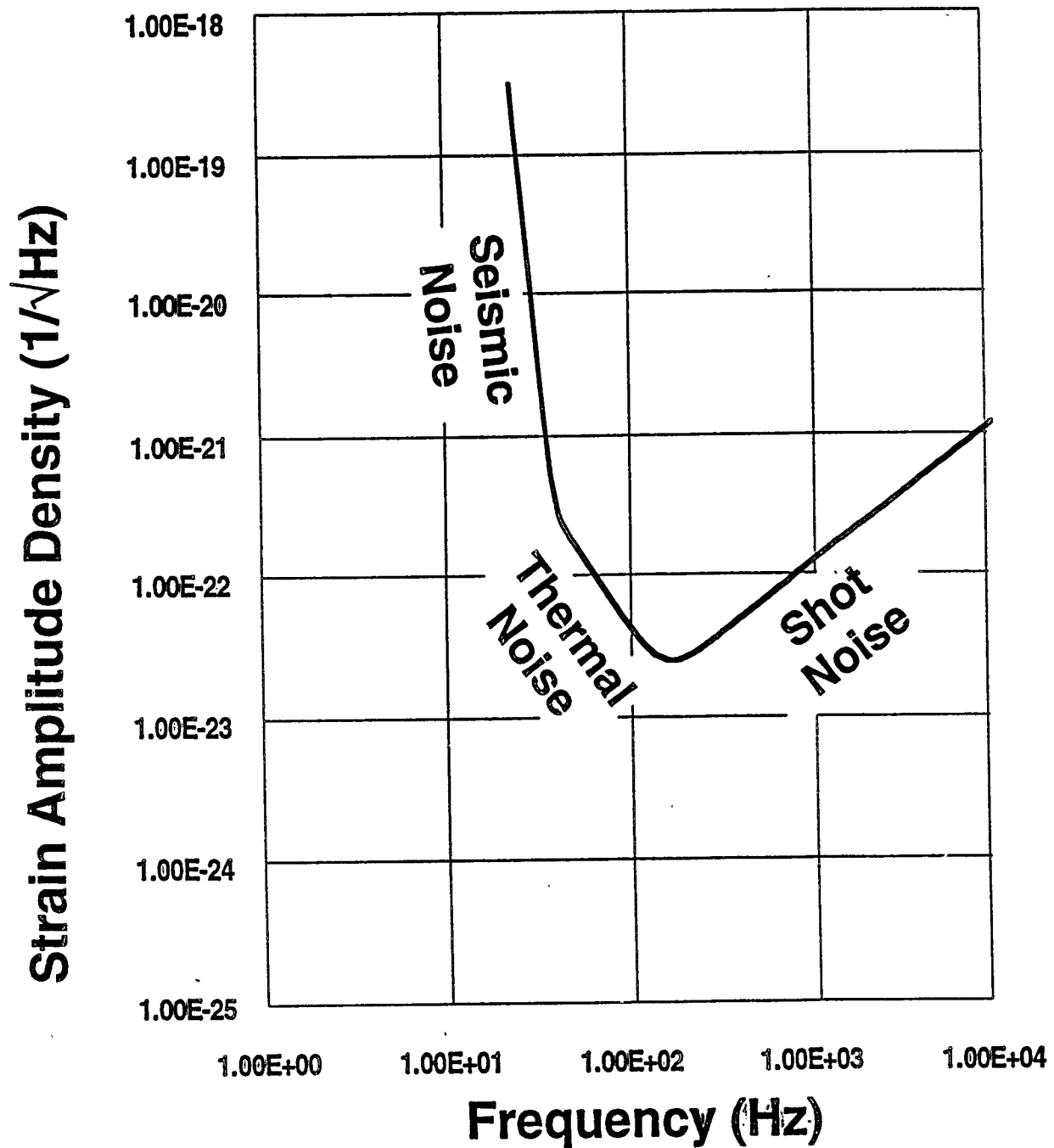

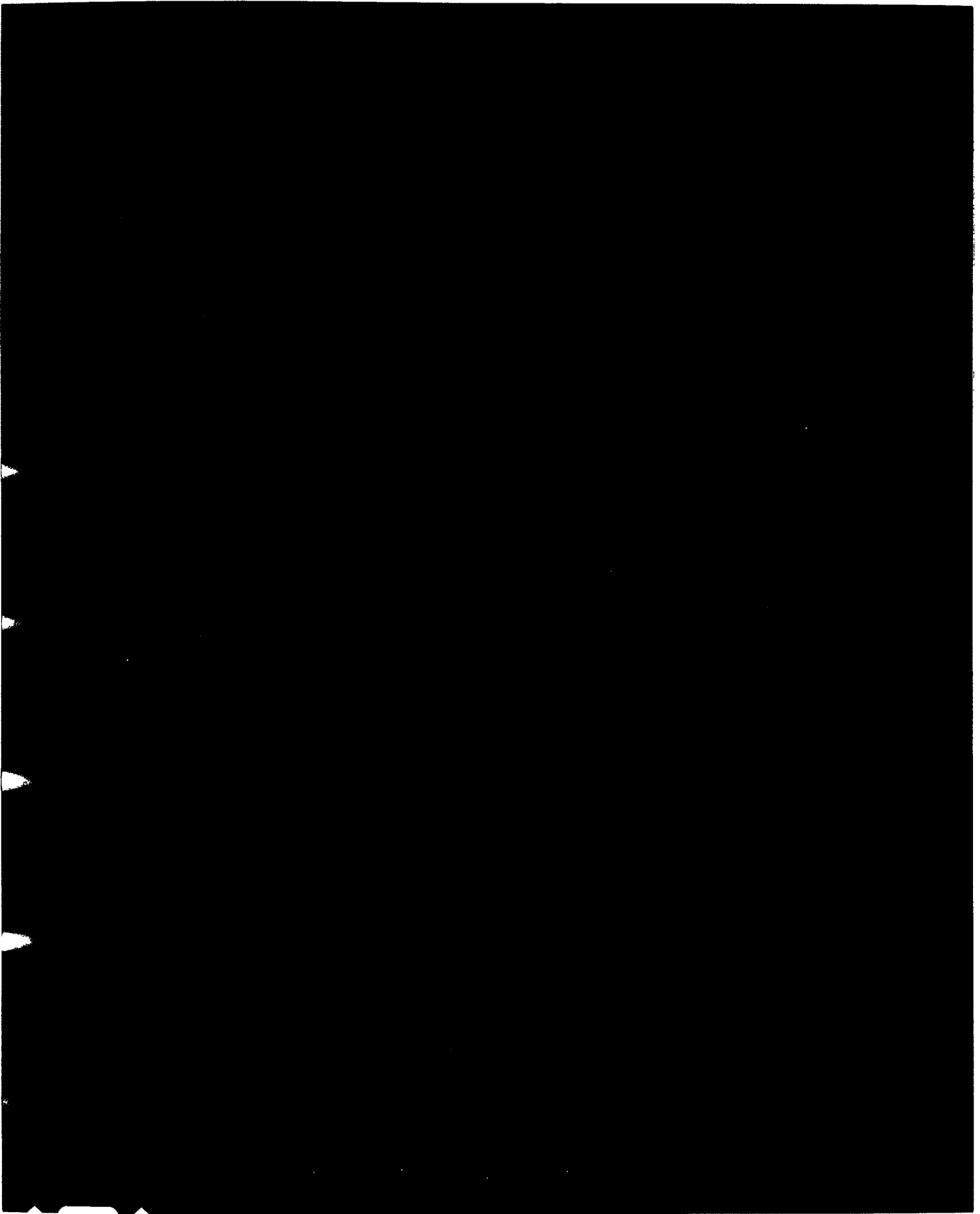

# Displacement Sensitivity of 40-Meter Interferometer

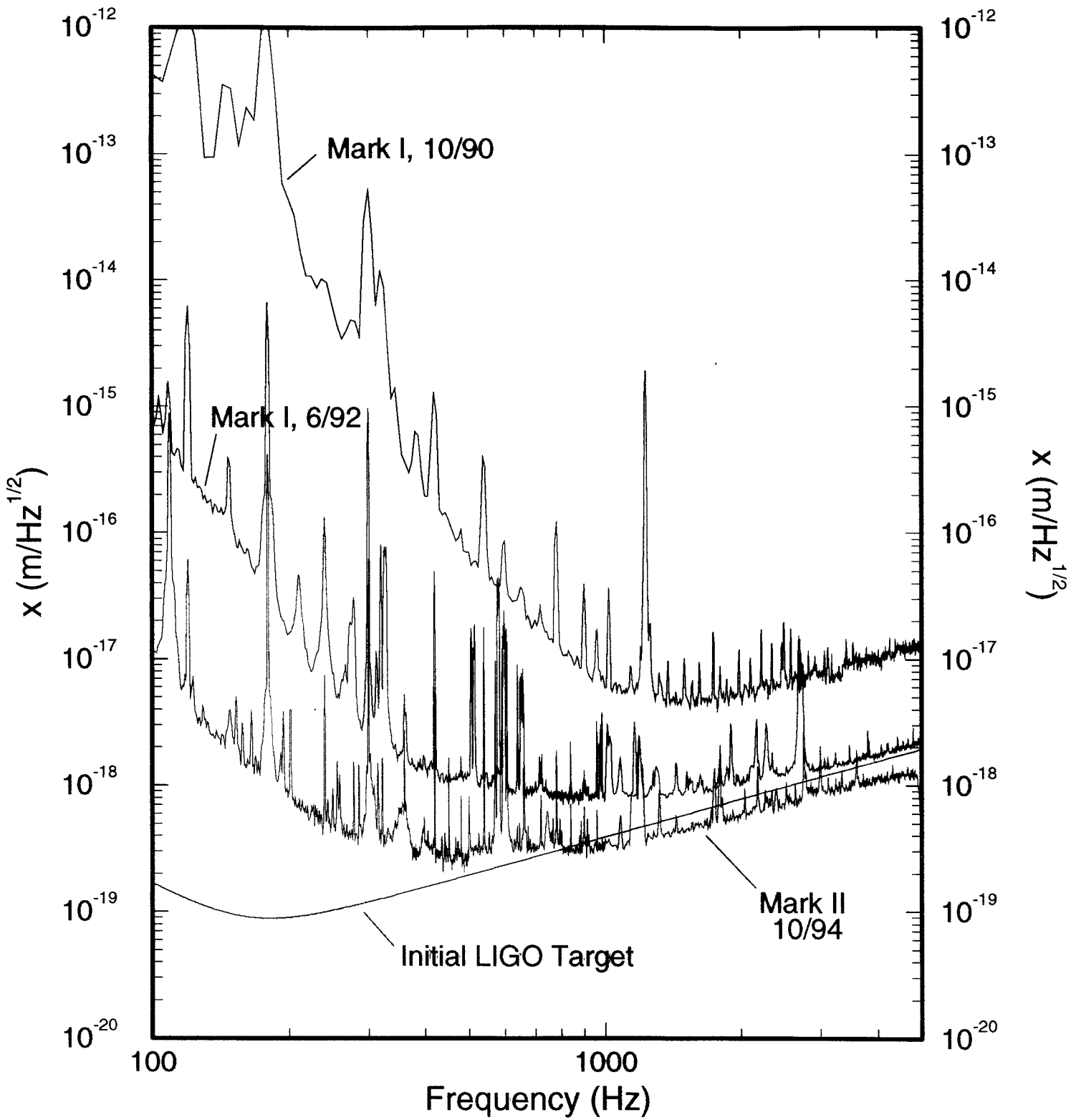

# Phase Noise Sensitivity From MIT Interferometer

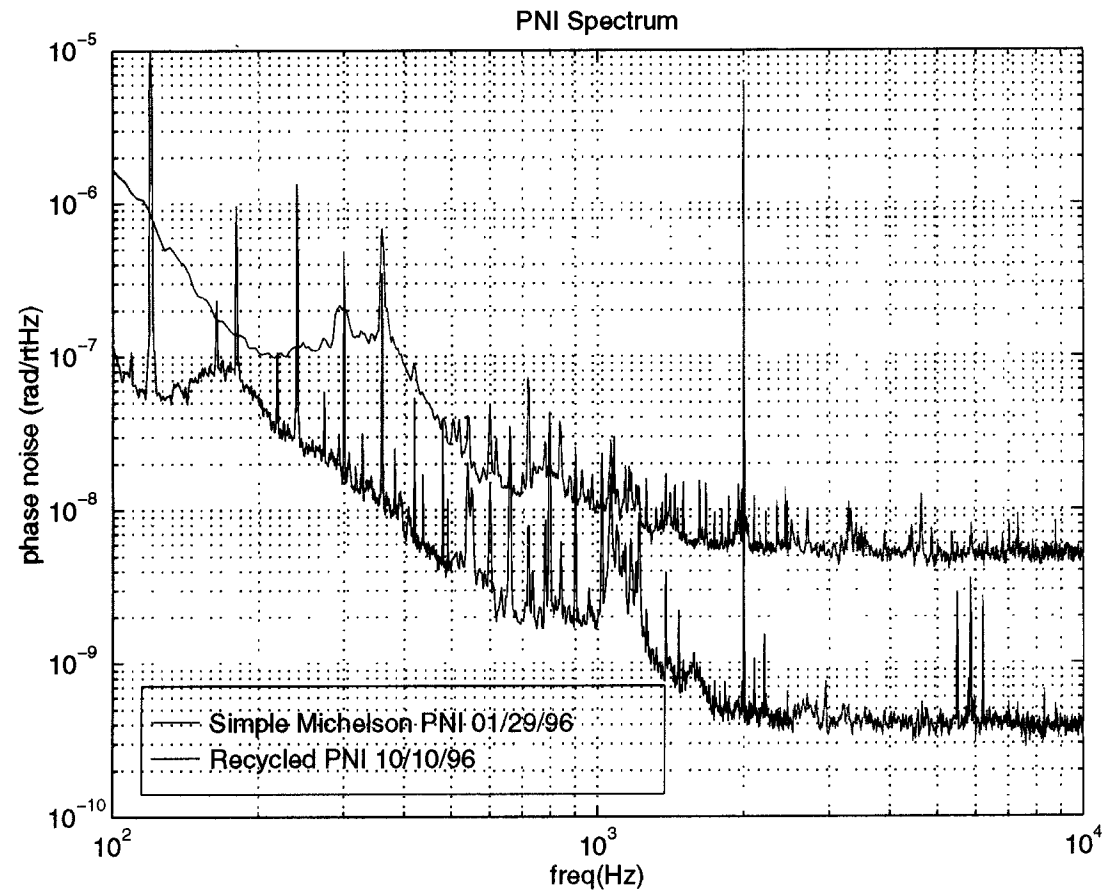



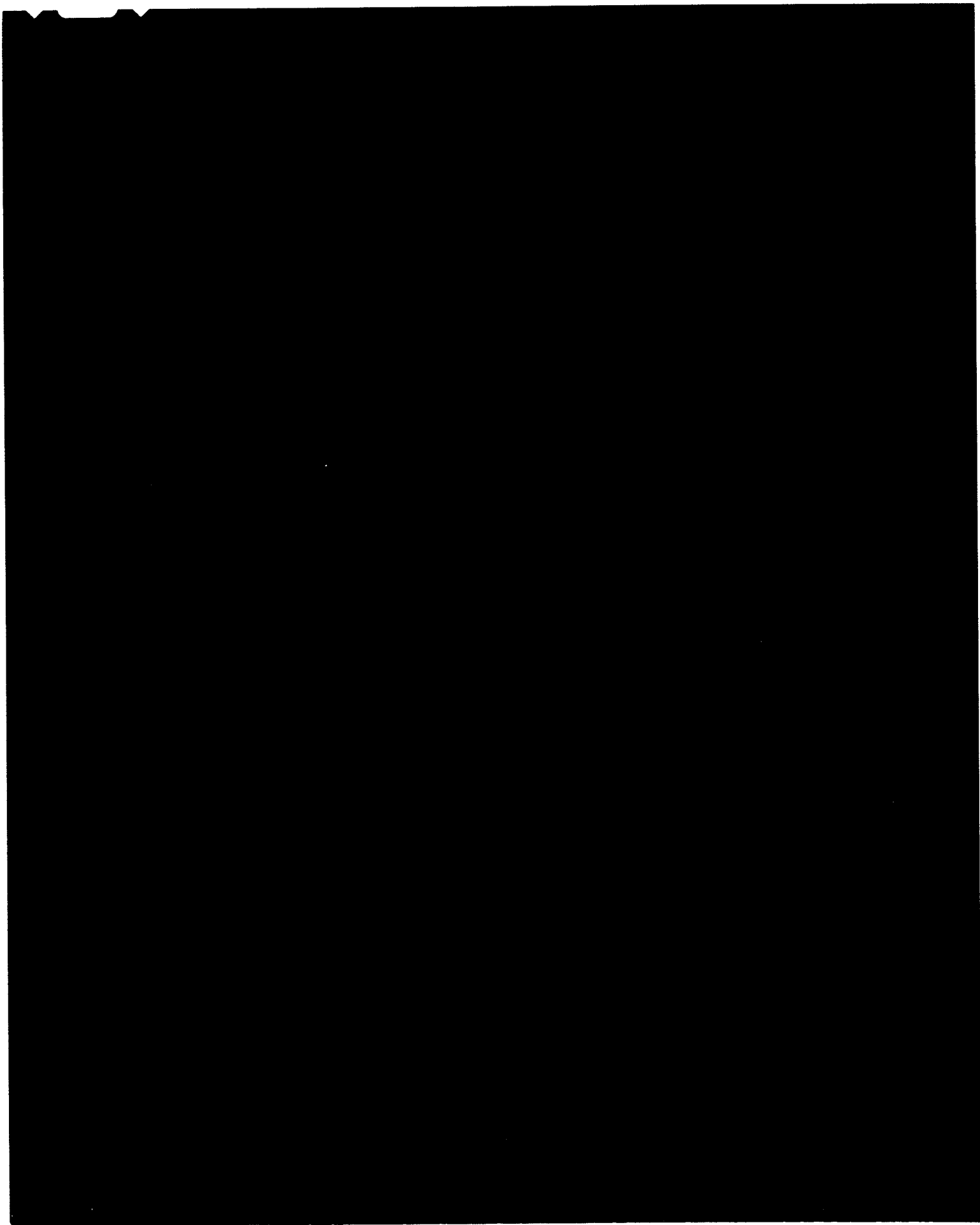

# NEUTRON STAR BINARIES

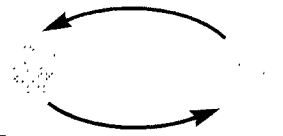

[“Near-Guaranteed” source]

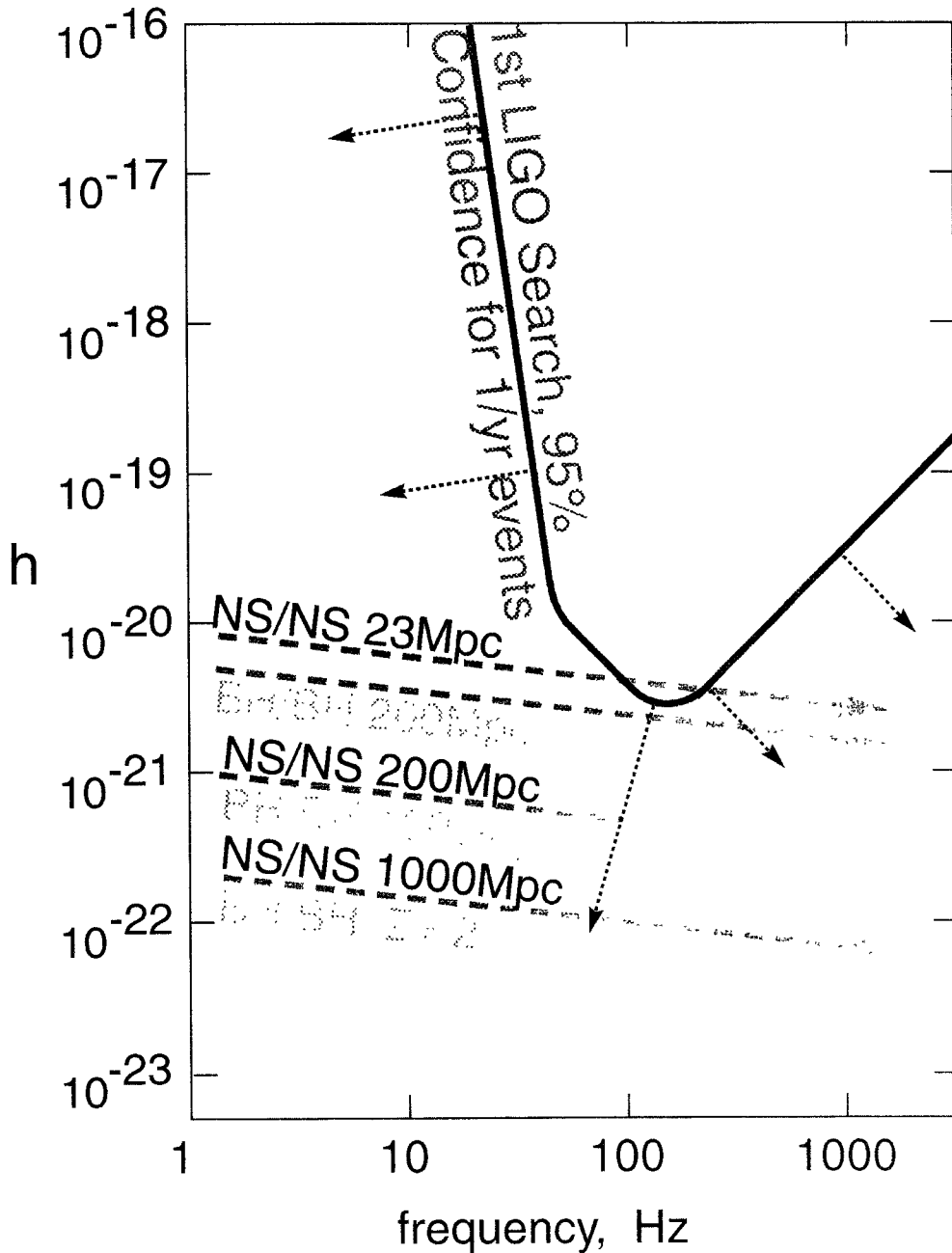

■ 15 minutes & 10,000 orbits in LIGO band

■ Rich information in waveforms:  
masses, spins, distance, direction,  
nuclear equation of state

# Steps in the Advanced Subsystems Research

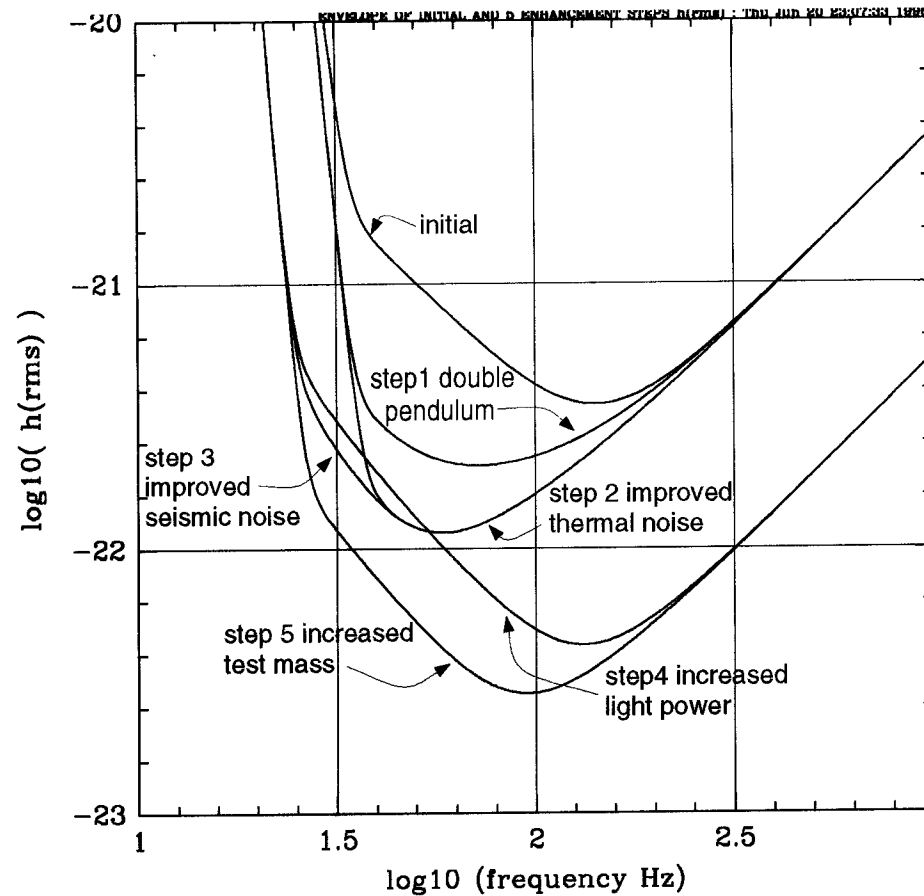

# $h_{\text{rms}}$ Noise Envelopes for Initial LIGO and Advanced Subsystems/Detectors

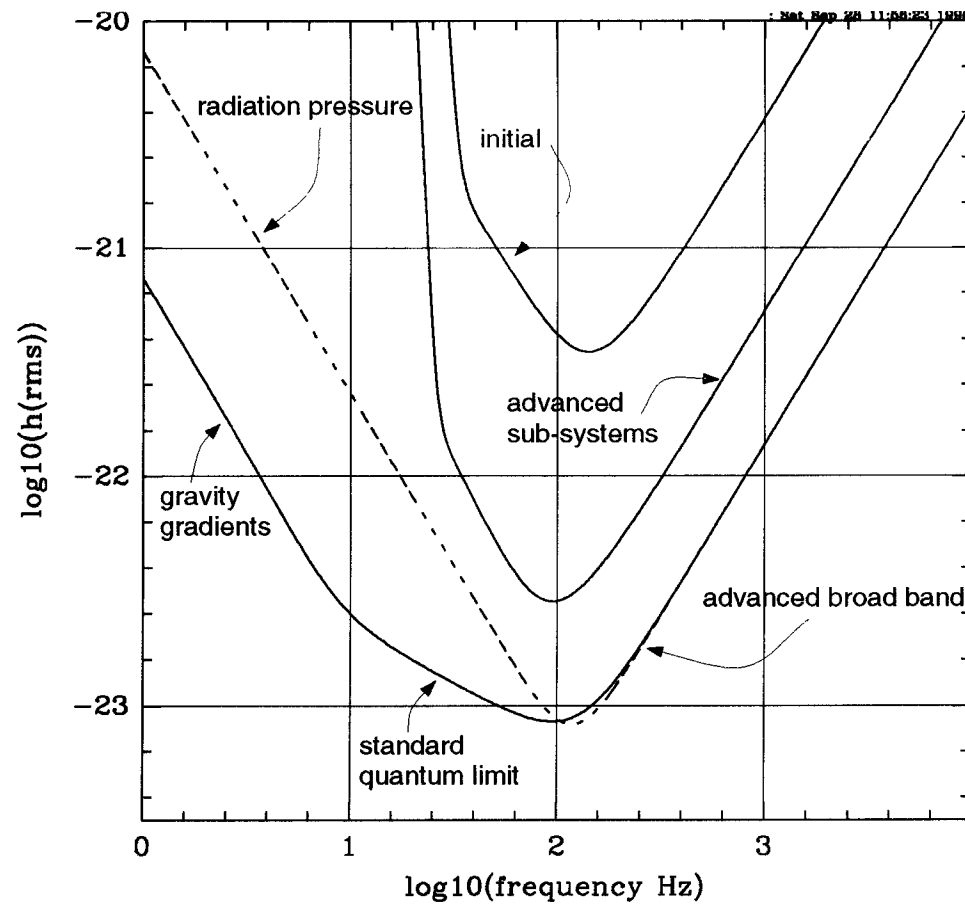

BB  
AHH

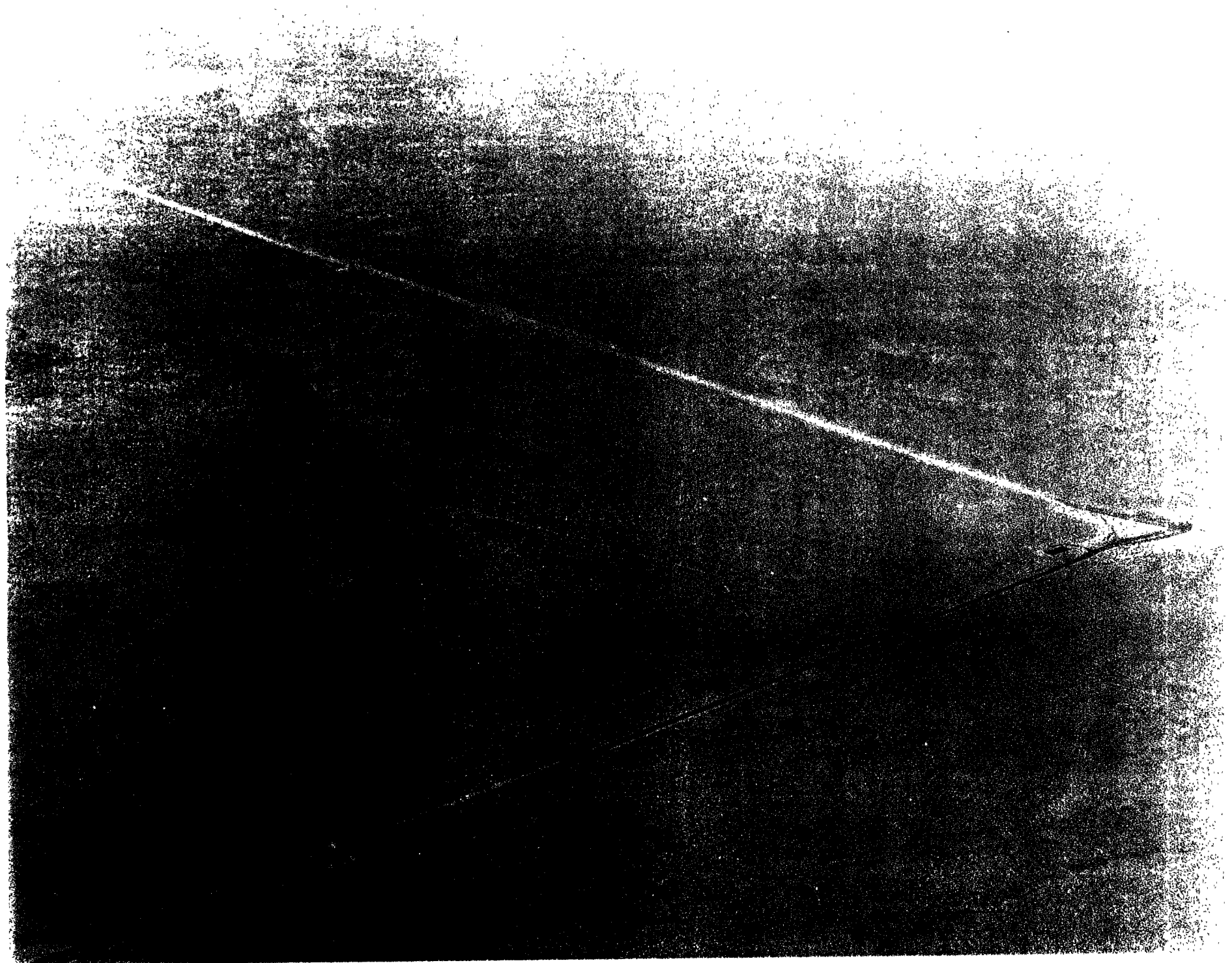

# Beam Tube

---

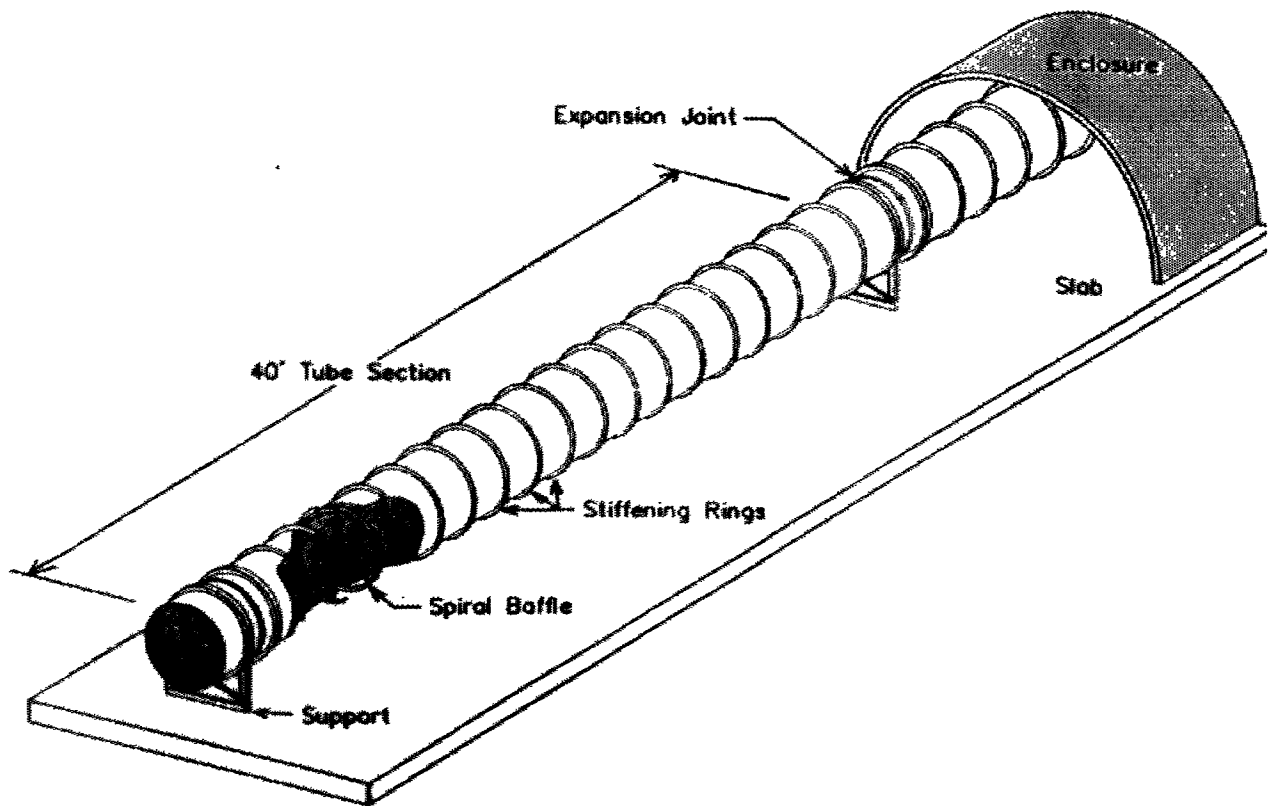

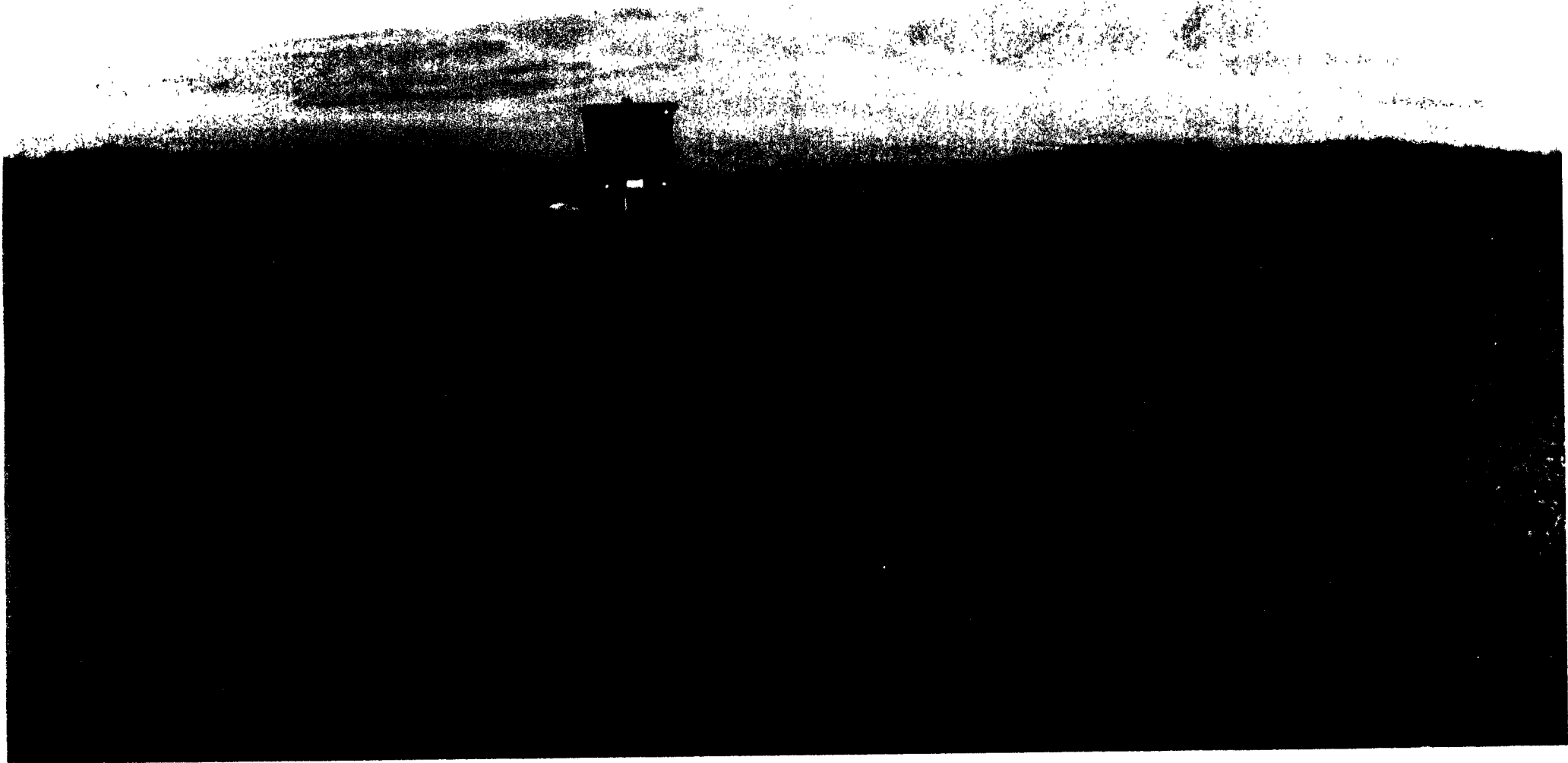



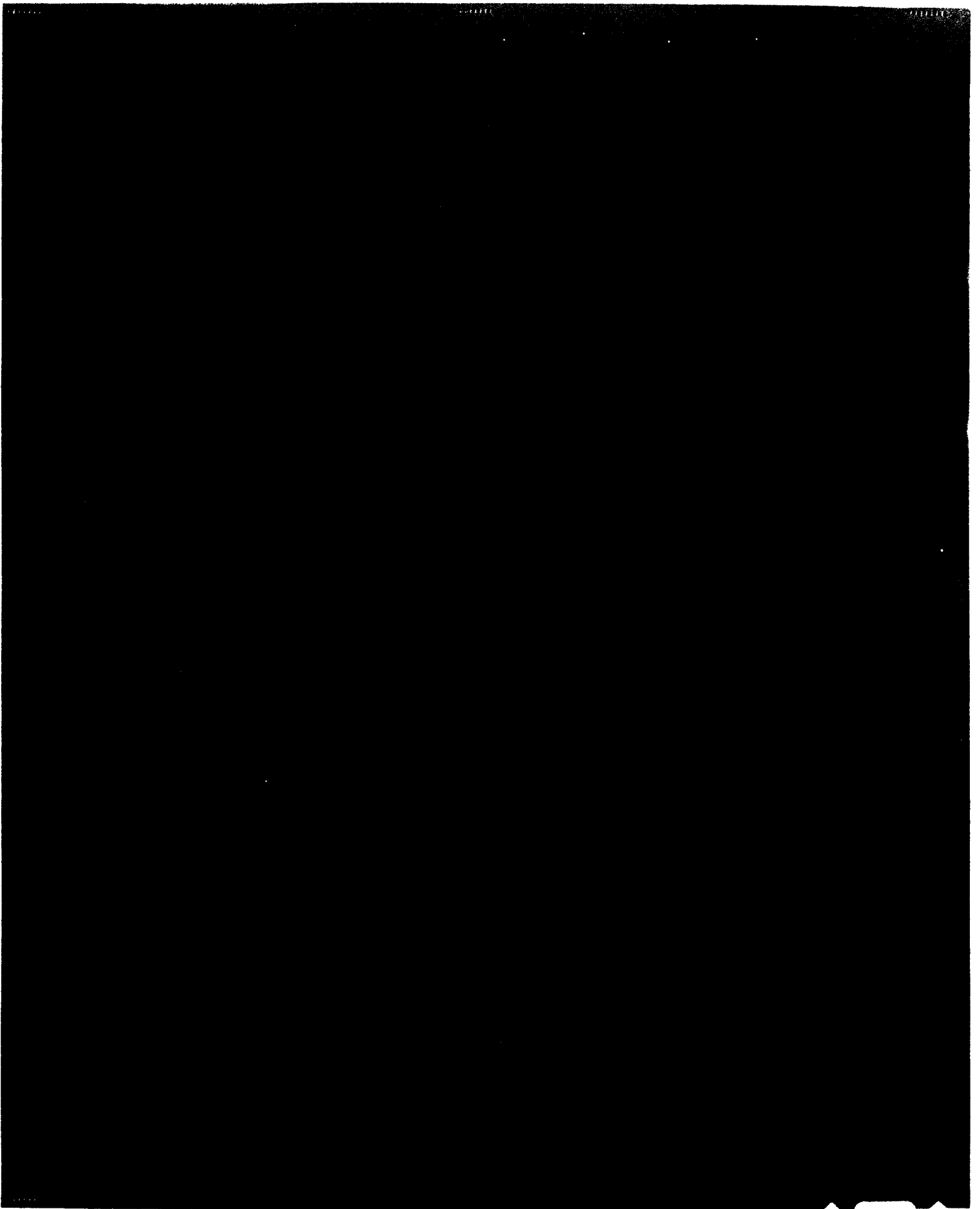

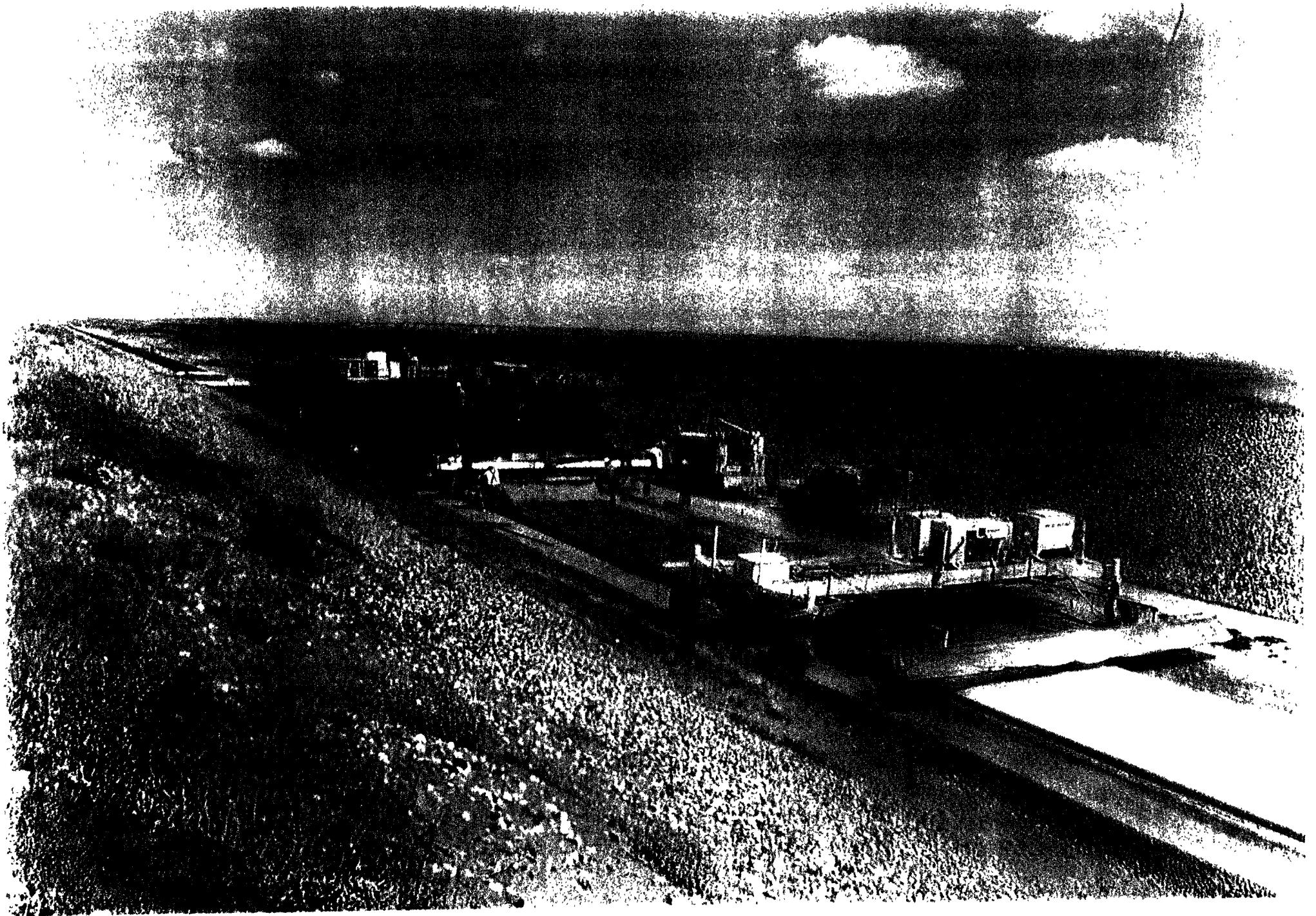

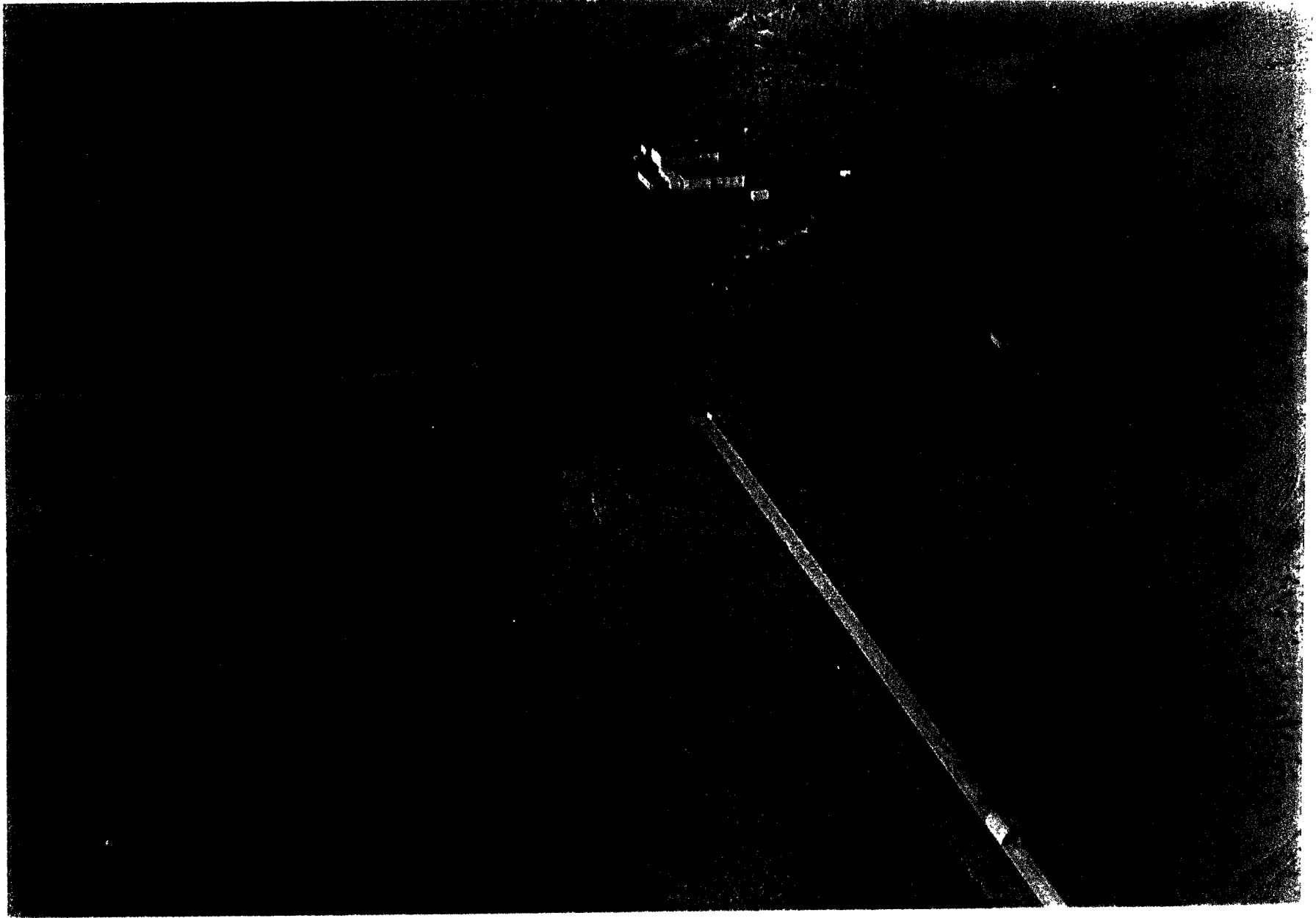

# LIGO Facilities

## *Beam Tube Enclosure*

---

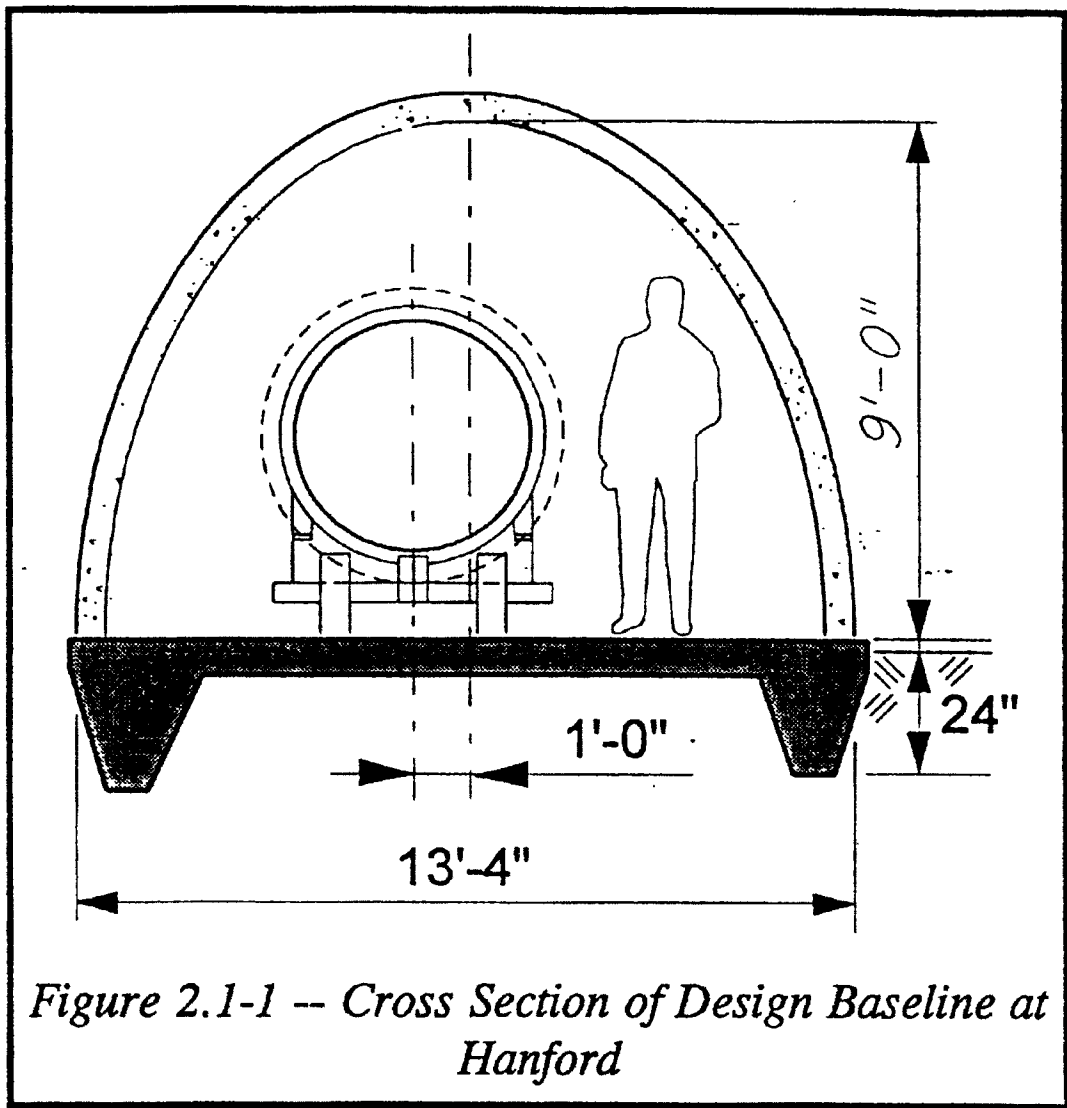

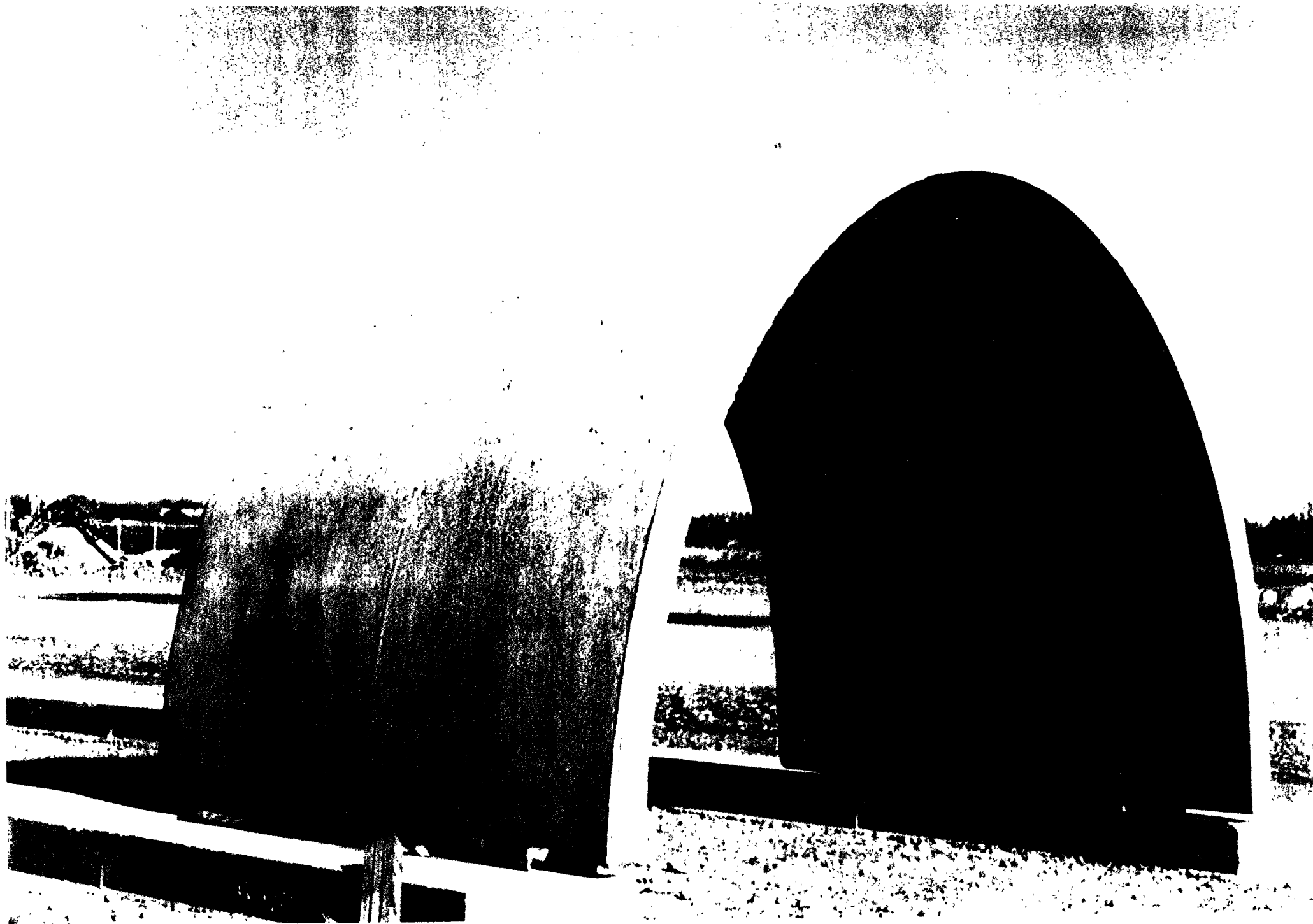

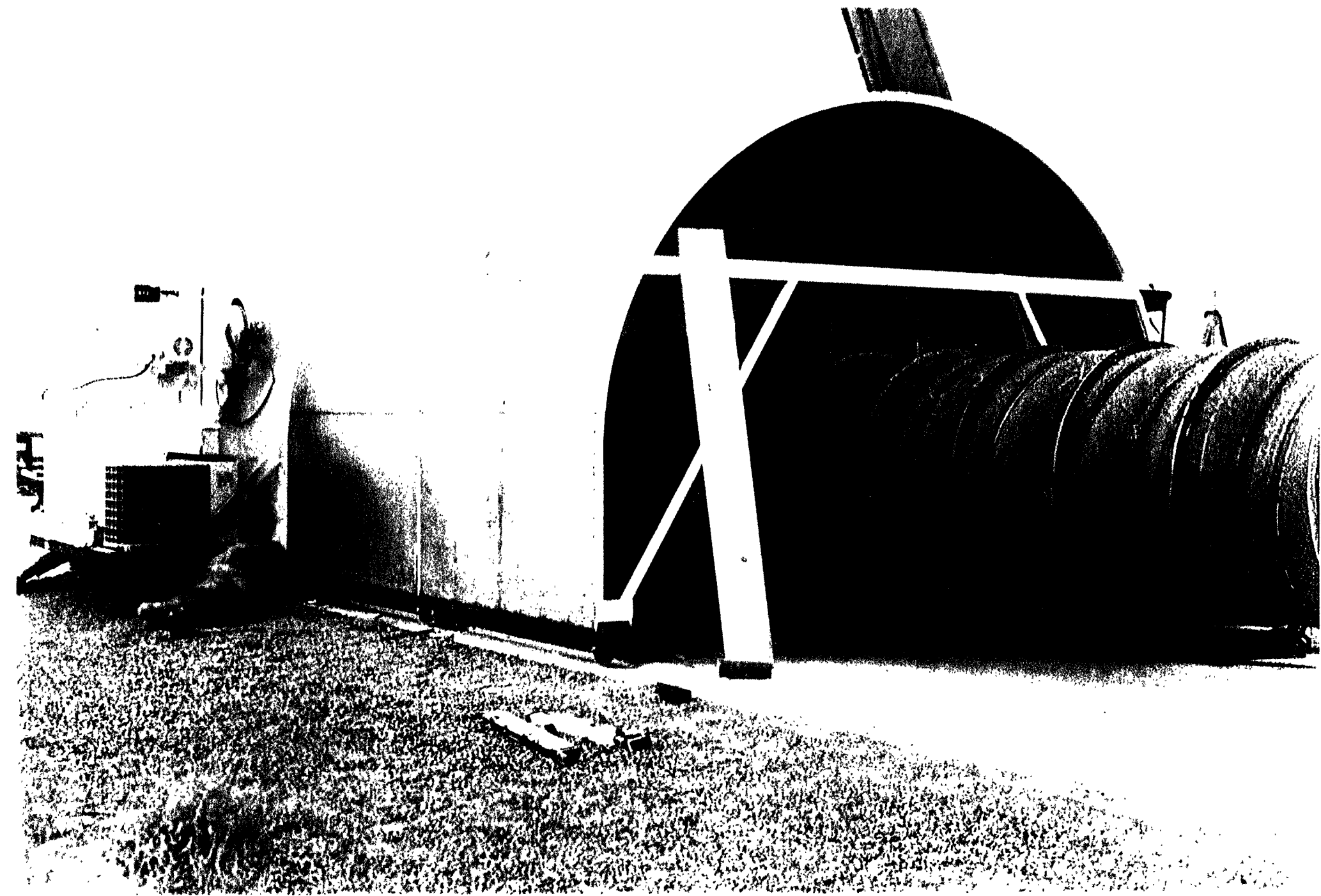

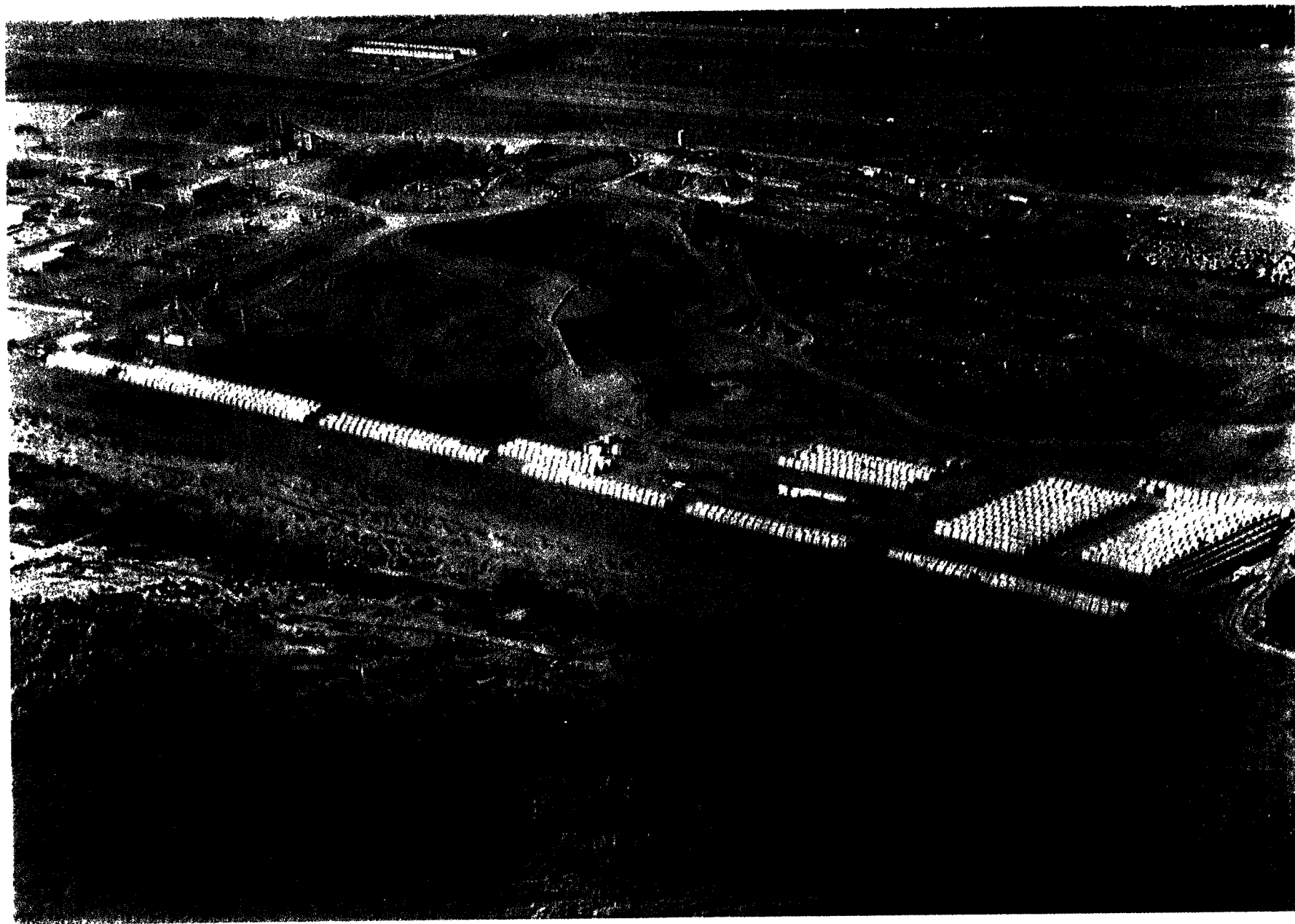

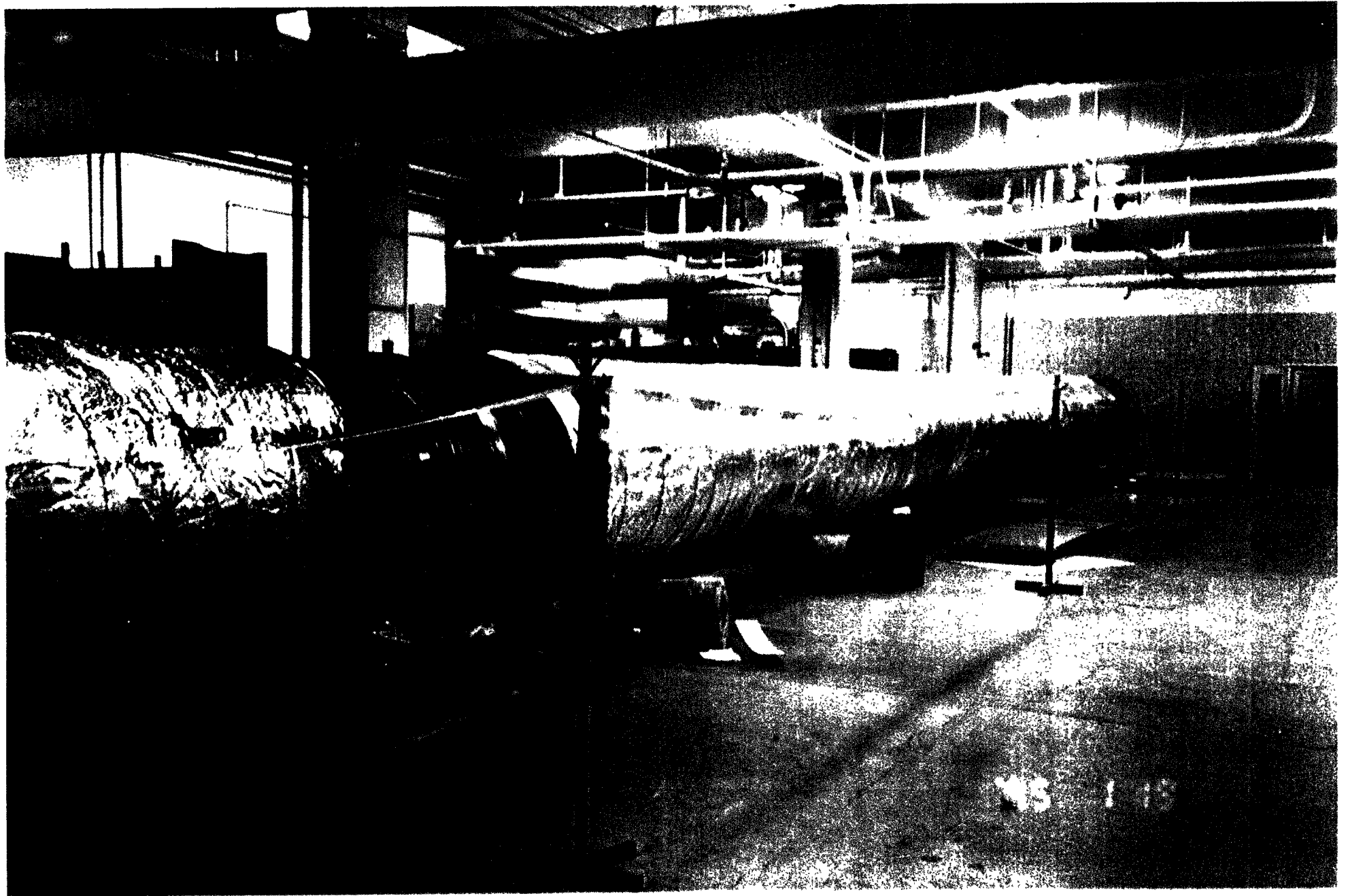



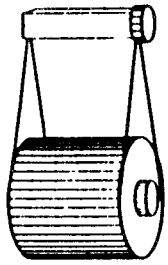

1

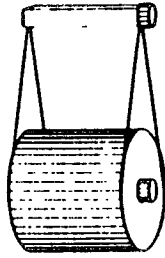

2



3

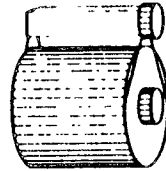

4



5



6

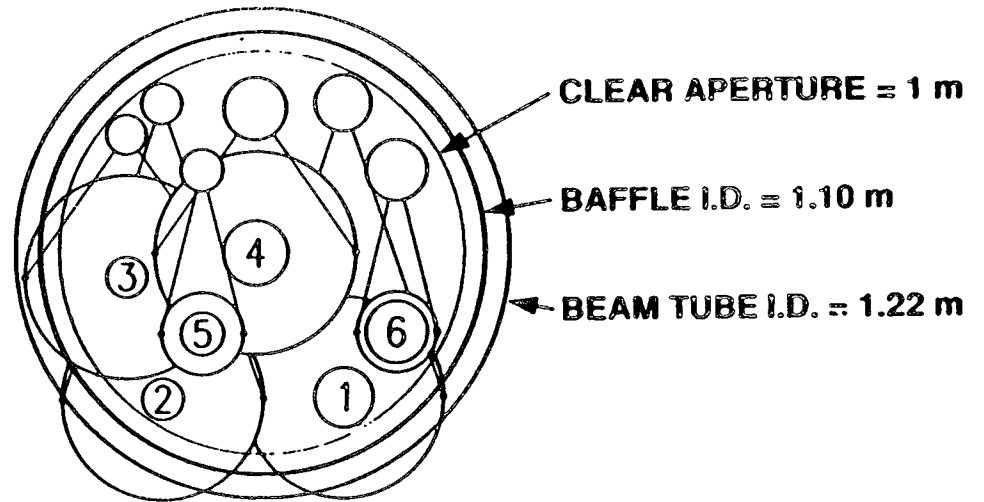
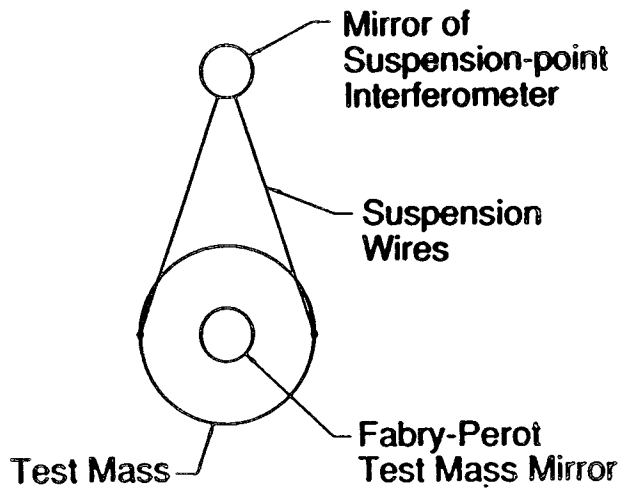



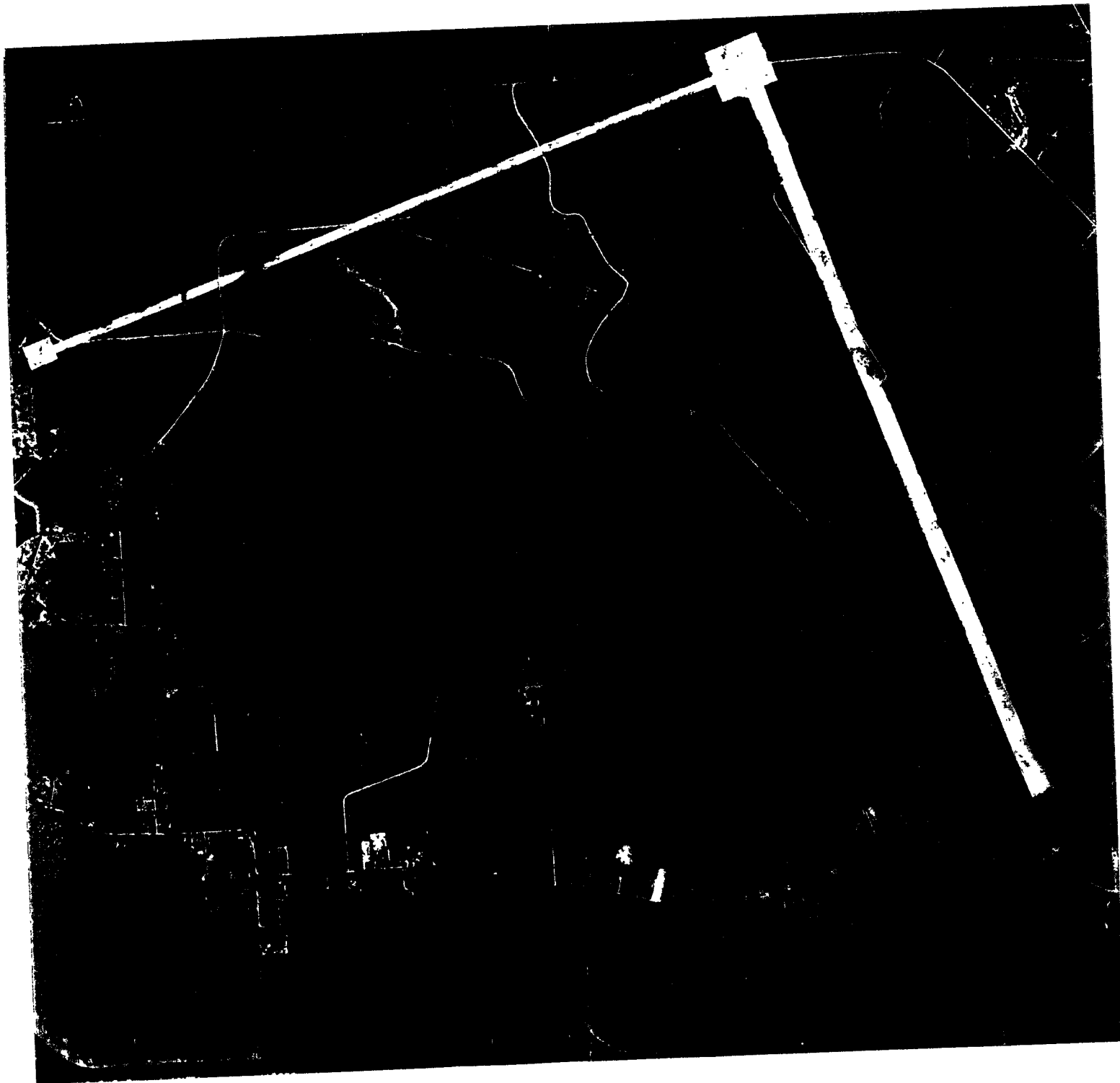

**LIGO**

LIVINGSTON PARISH

LOUISIANA

1A

AERIAL PHOTO BY:

GULF COAST AERIAL MAPPING

FLOWN: AUGUST 25, 1995

ALTITUDE: 12,000 FEET



G960028-17-O-V



# Conclusions

---

LIGO Construction is well Underway

Direct Detection of Gravitational Waves Appears Realistic within 10 years

Ultimate Sensitivities Capable of Opening a New Field of Observational Astronomy with Gravitational Waves is the Long Term Goal.

# NEUTRON STAR BINARY

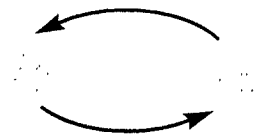

*[“Near-Guaranteed” source]*

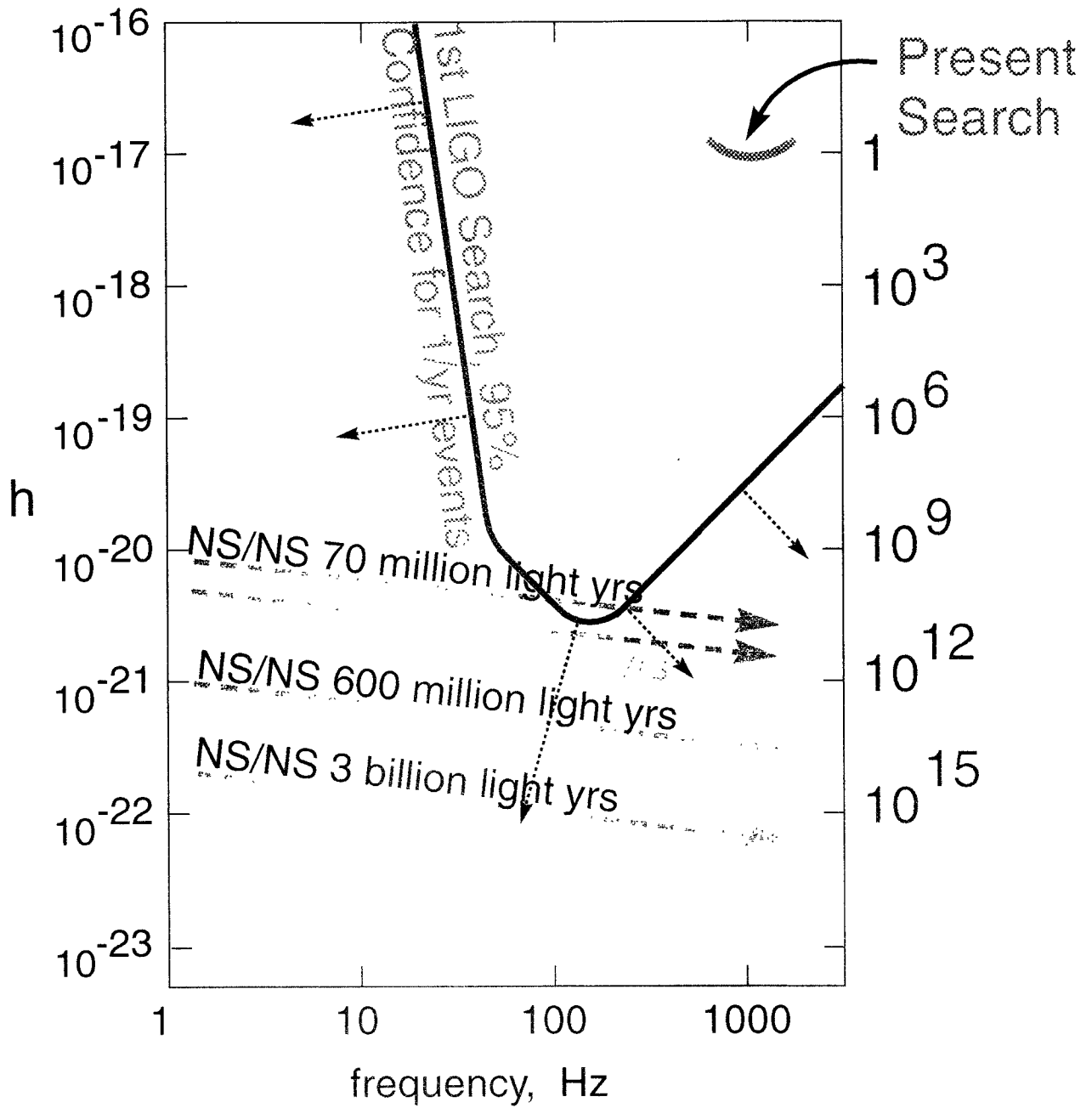

■ *15 minutes & 10,000 orbits in LIGO band*

■ *Rich information in waveforms:  
masses, spins, distance, direction,  
nuclear equation of state*