

# LIGO Vacuum Equipment Scientific Requirements Overview

M. E. Zucker  
LIGO Project  
Massachusetts Institute of Technology

30 March, 1995

## Envelope Volume, Dimensions & Interfaces

- Detector Subsystems in Vacuum
  - Core Optics
  - Input/Output Optics
  - Seismic Isolation Stacks
- Input/Output Optics: HAM Chambers
- Core Optics:
  - BSC Chambers
  - TMC Chambers
- Main and Auxiliary Laser Beams
  - Beam Size
  - Multiple Reflections, Internal Scattering & Beam Dumps
  - Auxiliary Beams for Alignment Controls
  - Beam I/O and Viewing Ports
- Access
- Independence of Interferometers Sharing Beam Tubes
- Modularity and Expansion Capability

# SCHEMATIC INTERFEROMETRIC DETECTOR

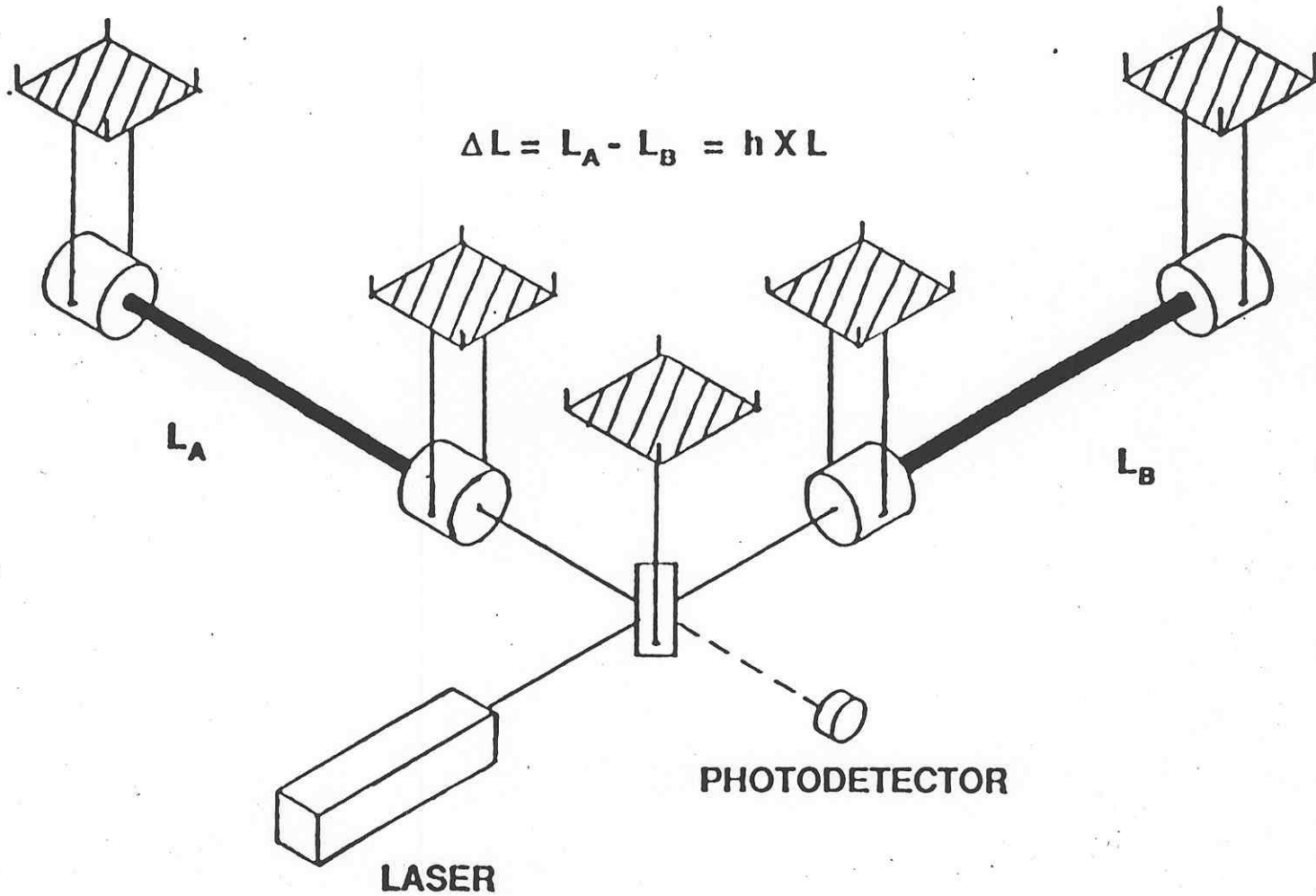

PHOTODETECTOR

LASER

$$h \leq 10^{-22}$$
$$\Downarrow$$
$$\Delta L \lesssim 4 \cdot 10^{-19} \text{ m}$$

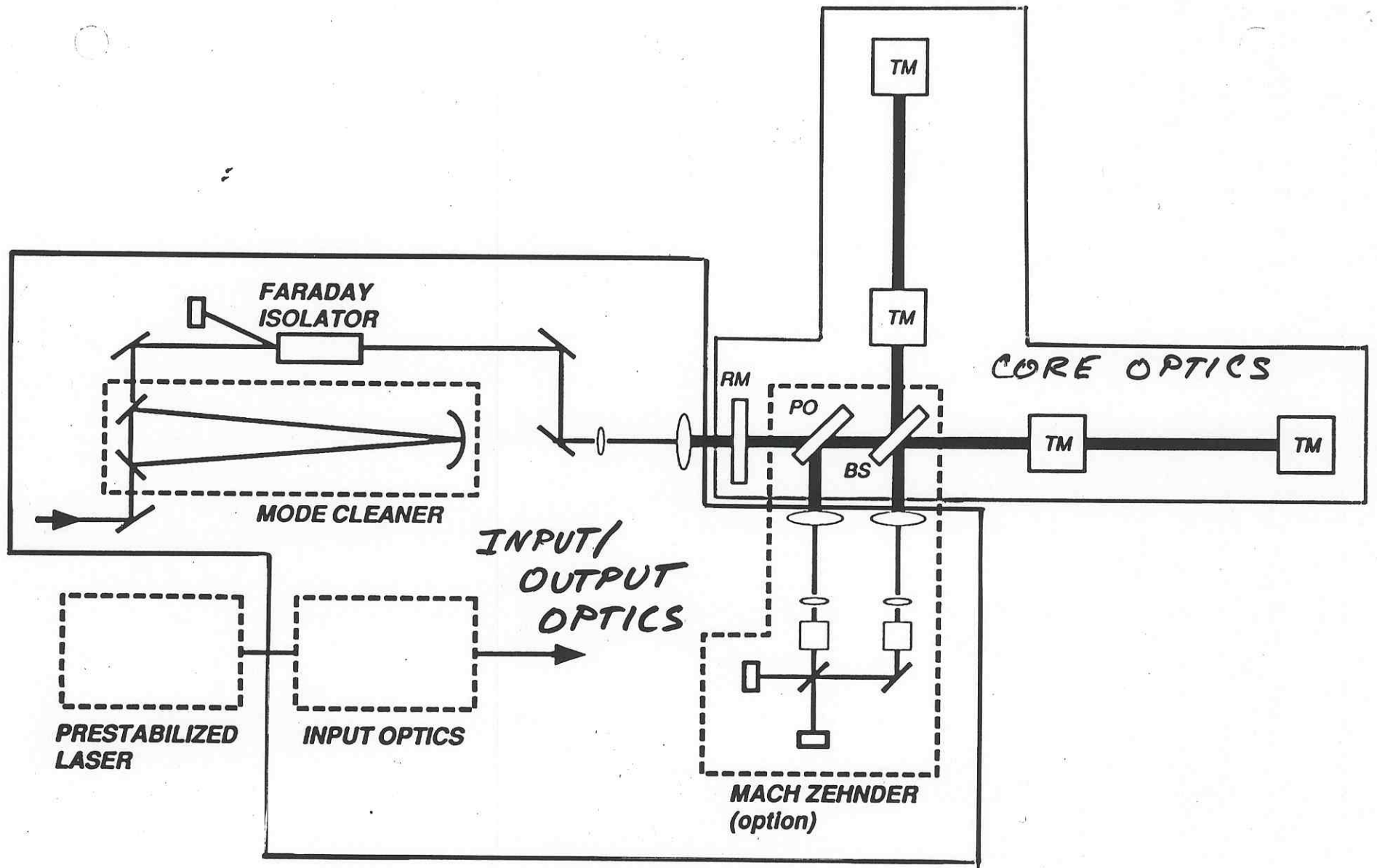

**GENERIC INITIAL INTERFEROMETER**

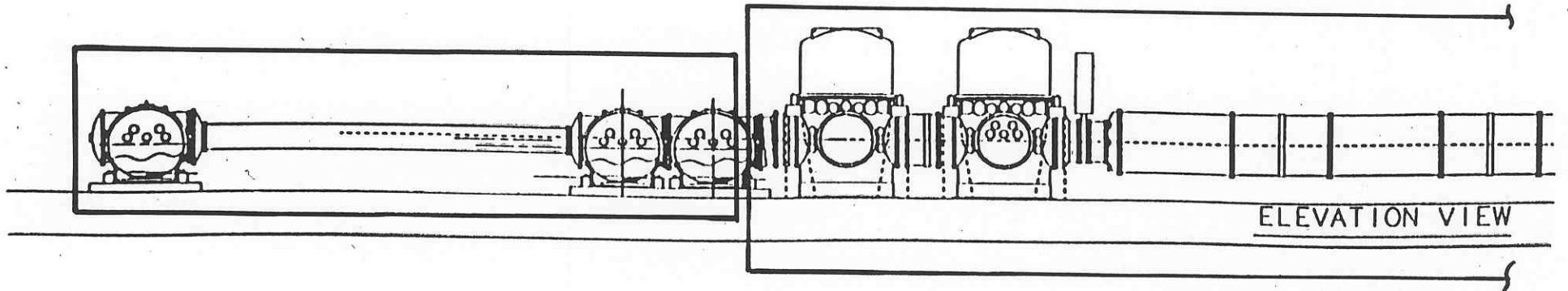
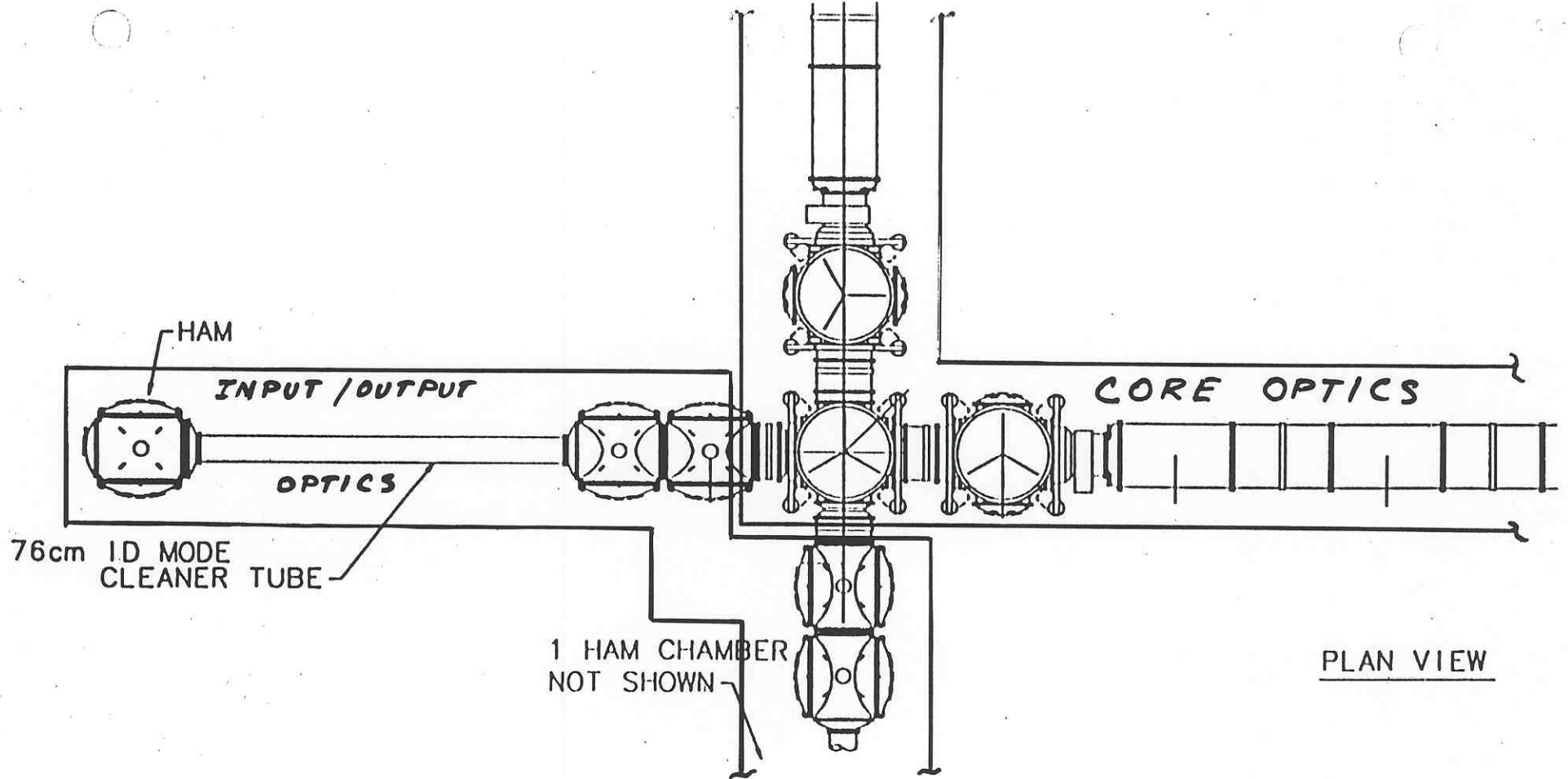



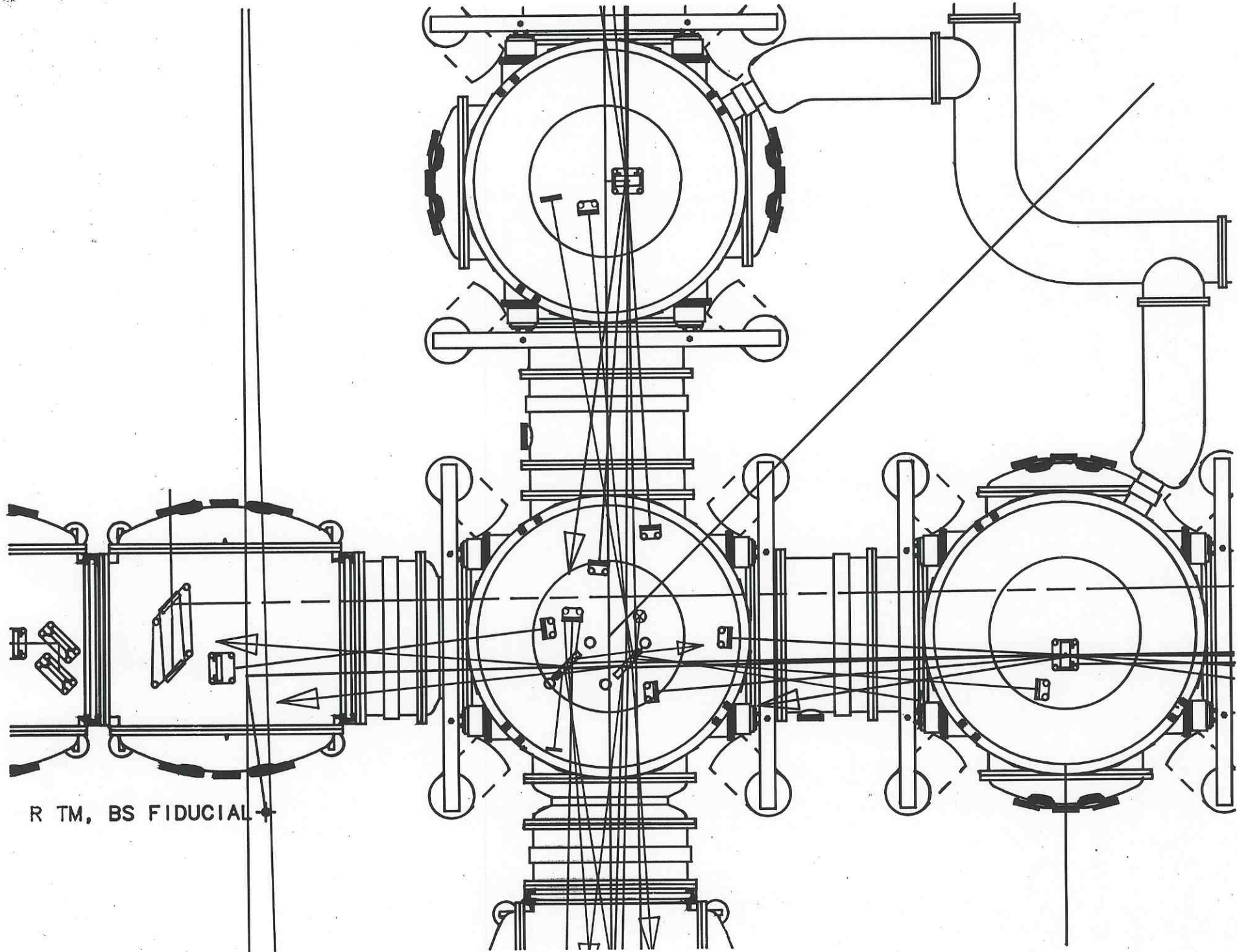

R TM, BS FIDUCIAL

# BEAMSPLITTER PRIMARY AND SECONDARY BEAM RAY TRACE

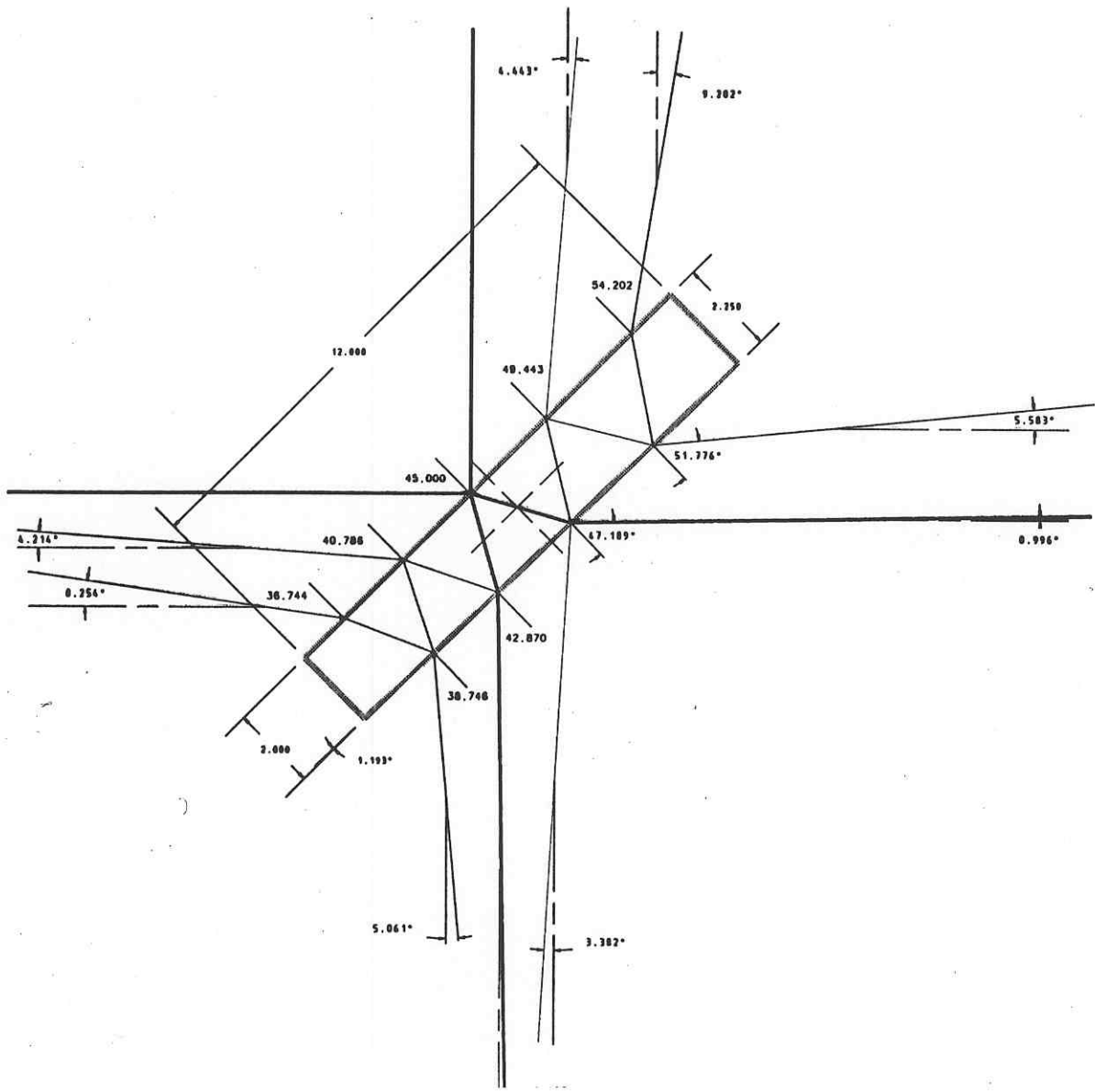

# Beam and Component Diameters

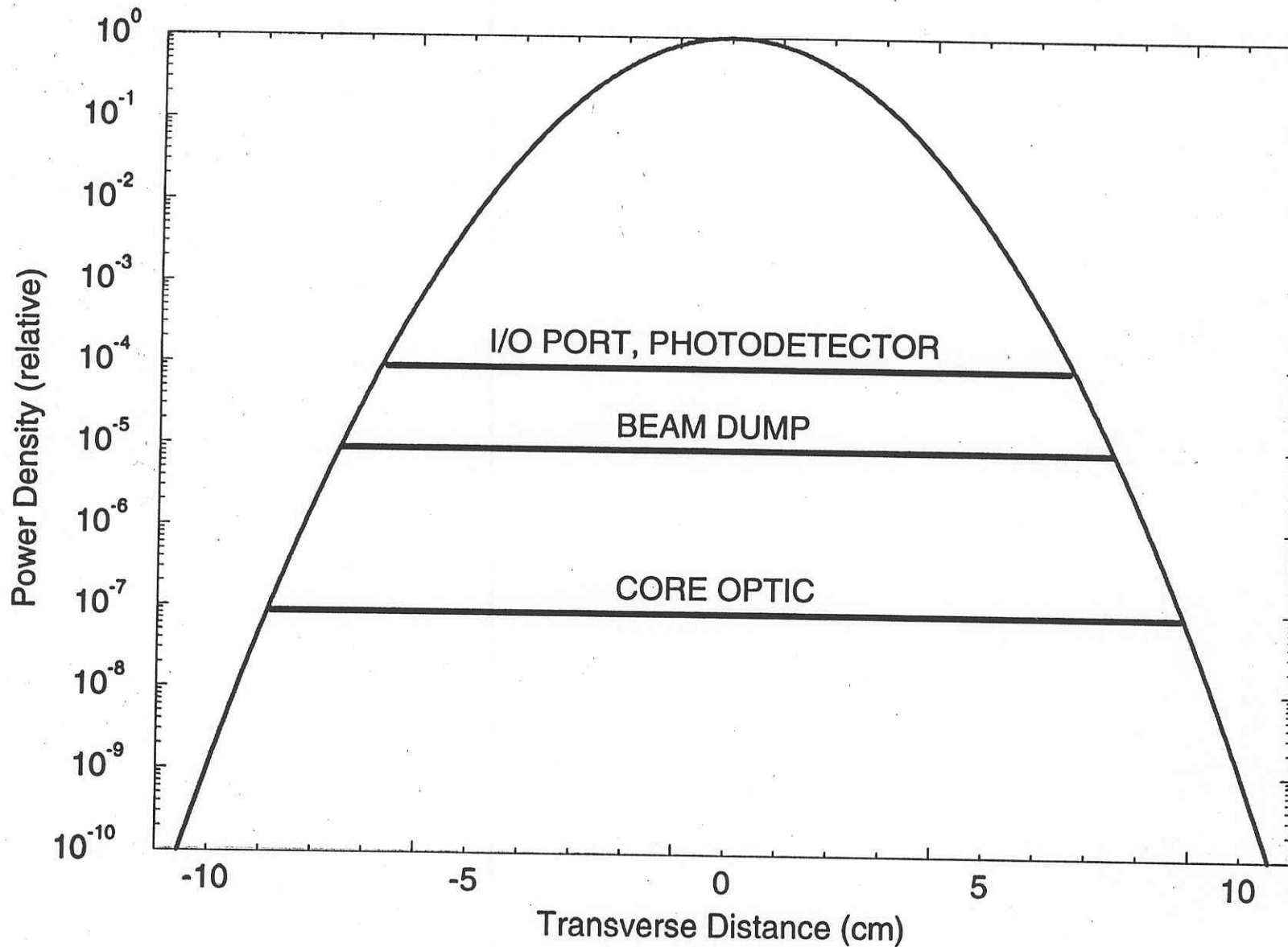



# AUXILIARY LASER ALIGNMENT

← 20-50 m →

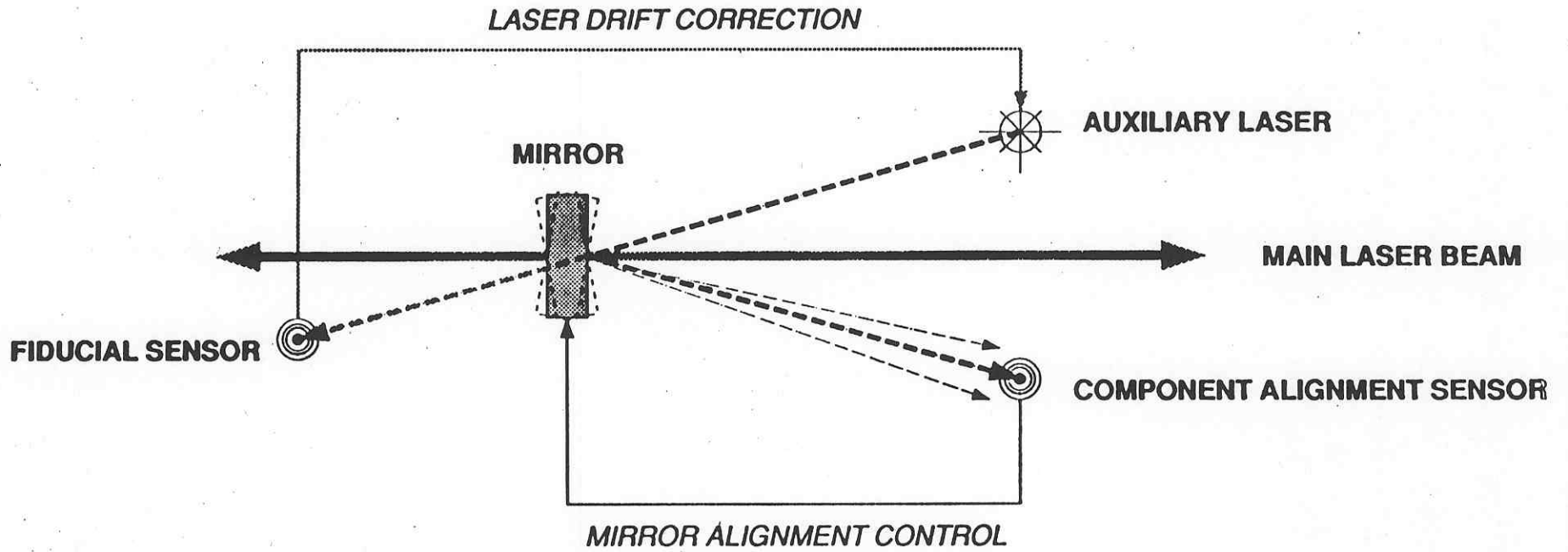

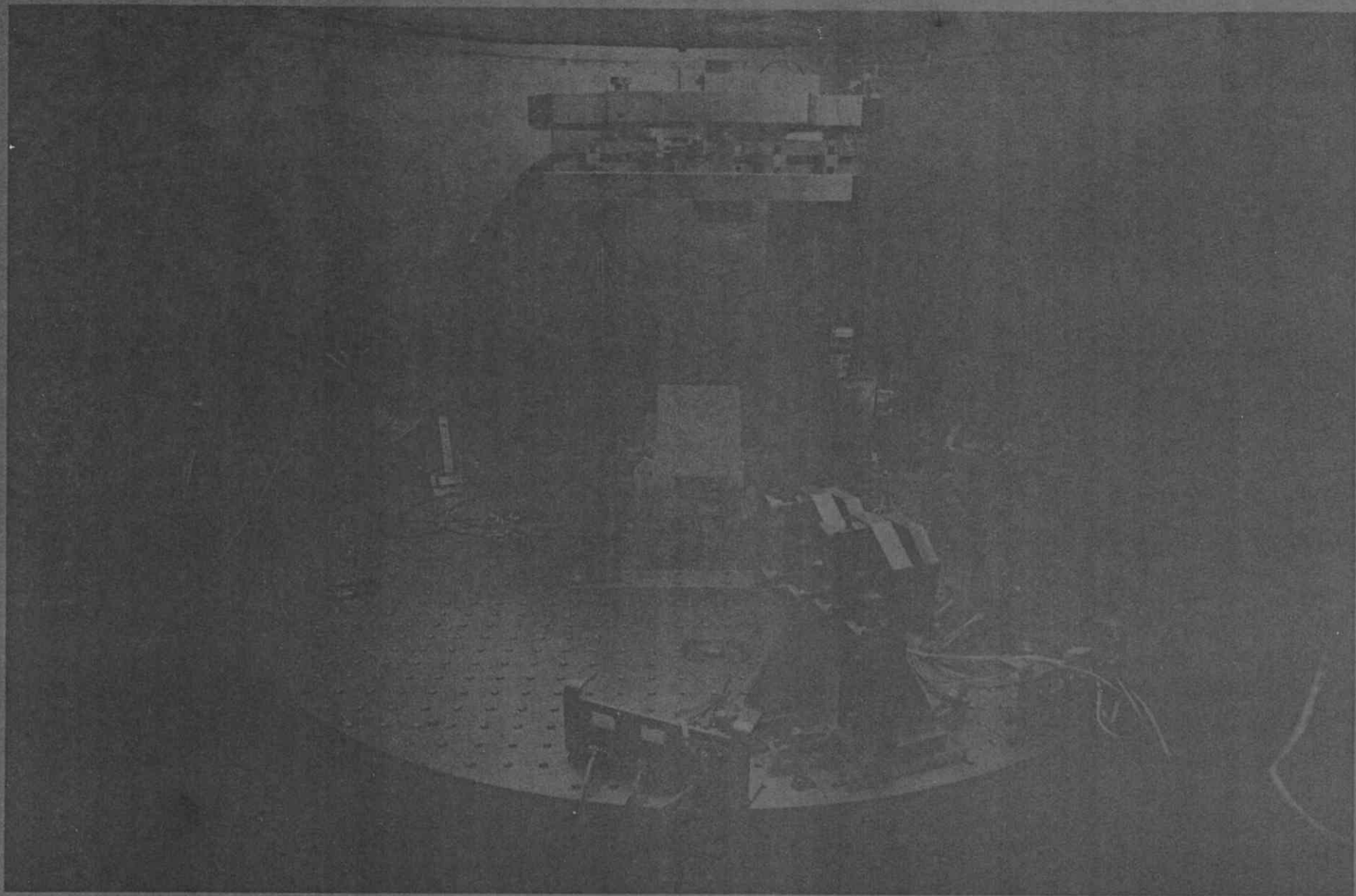

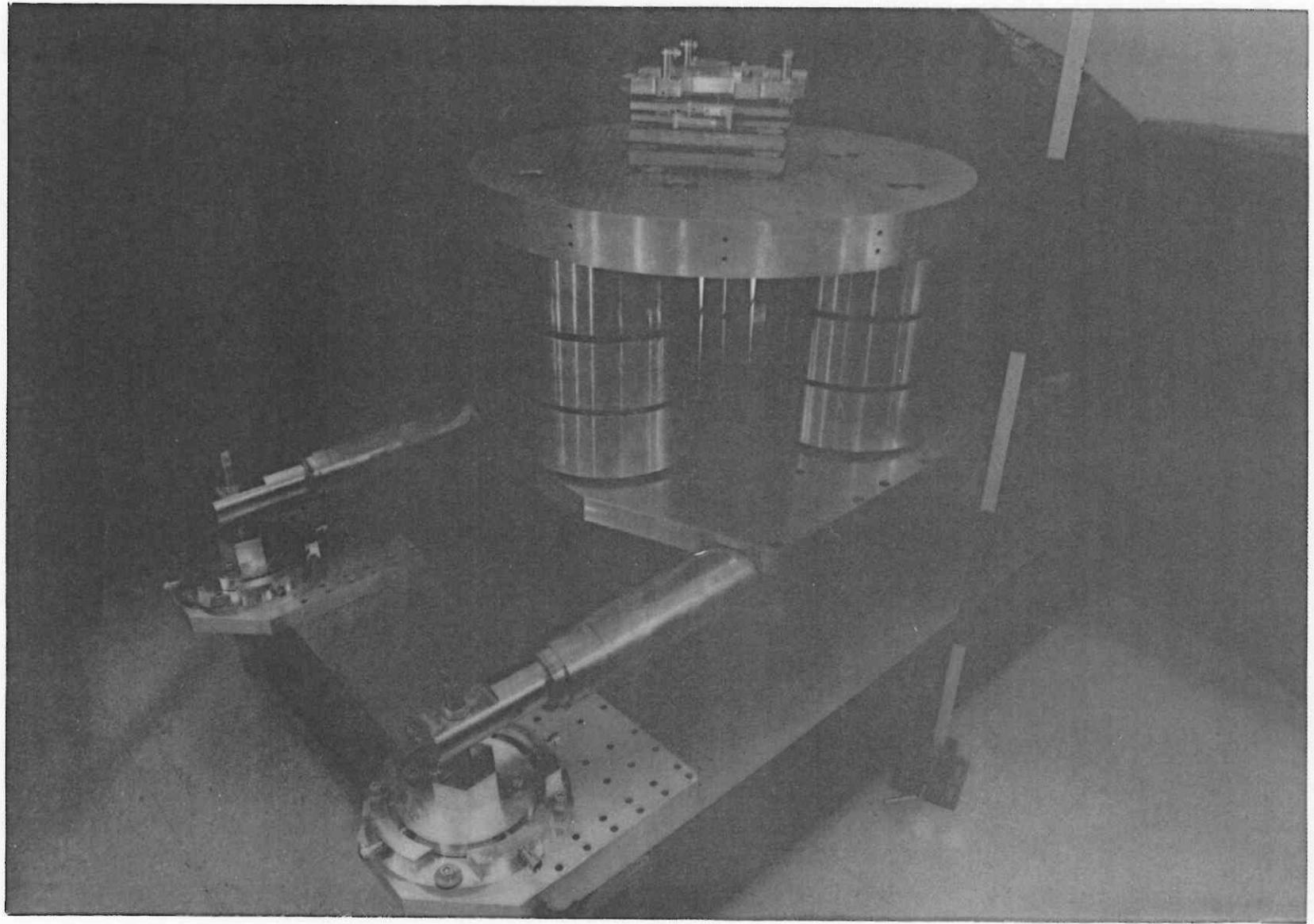



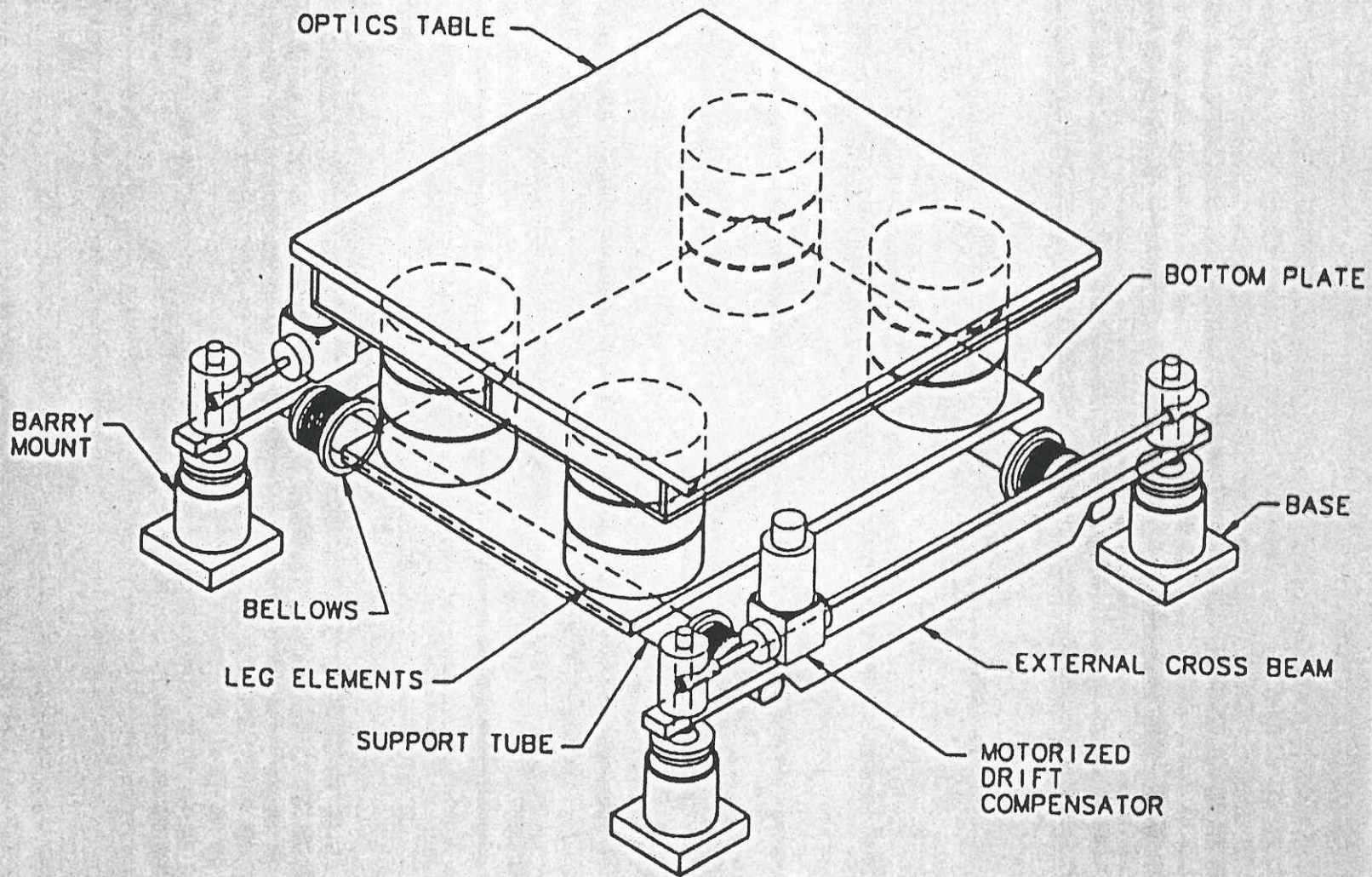

HAM SEISMIC ISOLATION

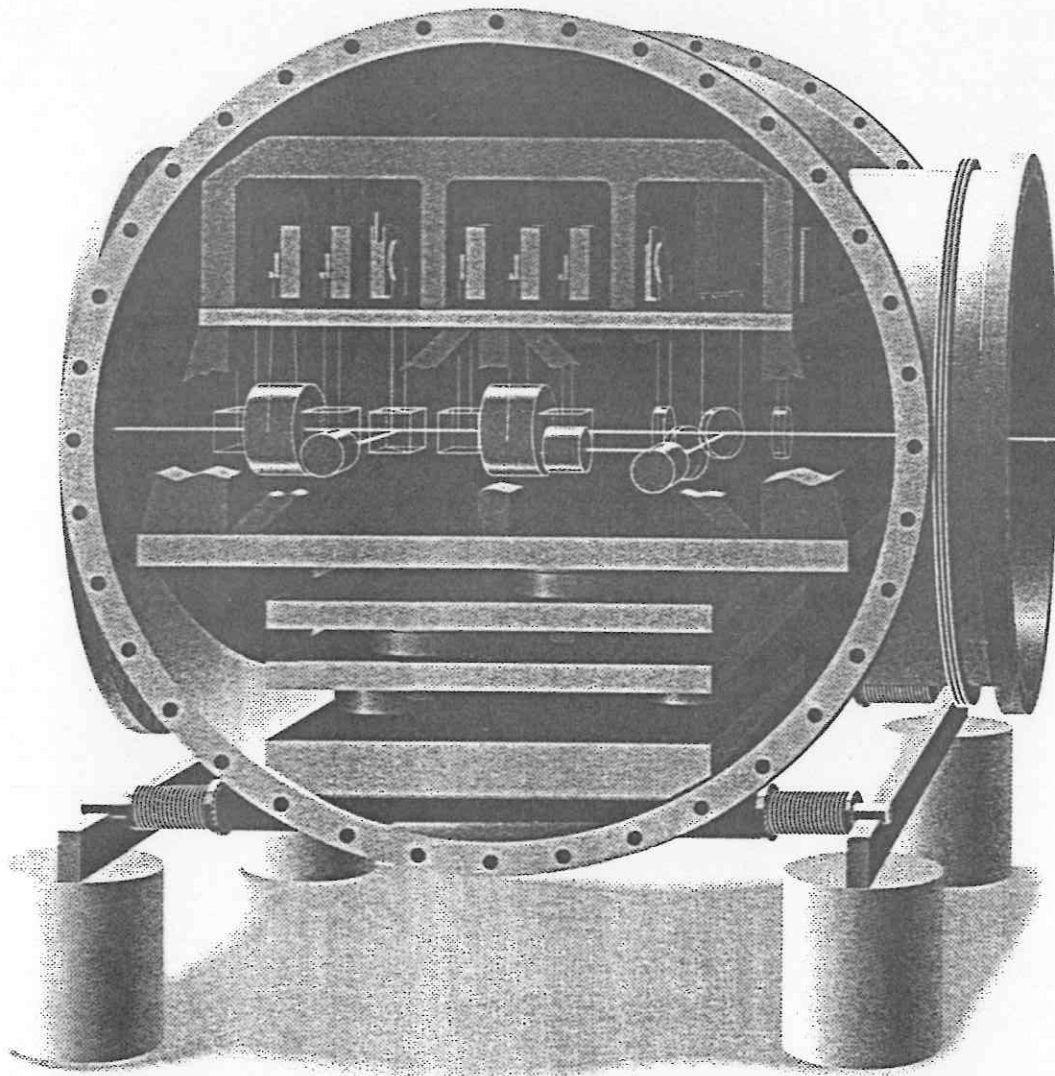



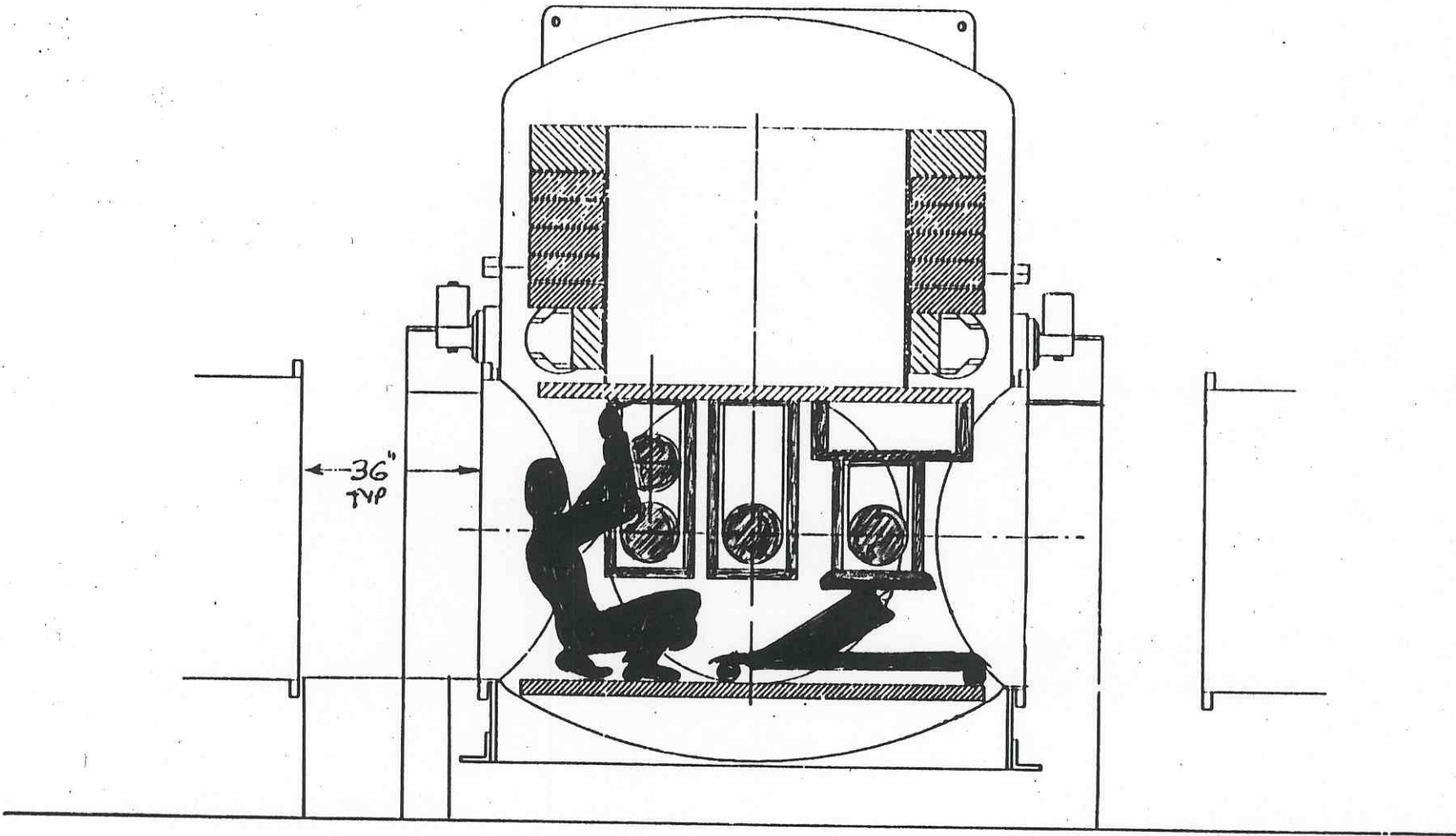

← 36"  
TYP →

INTERNAL ACCESS

*SD*  
9-2-92



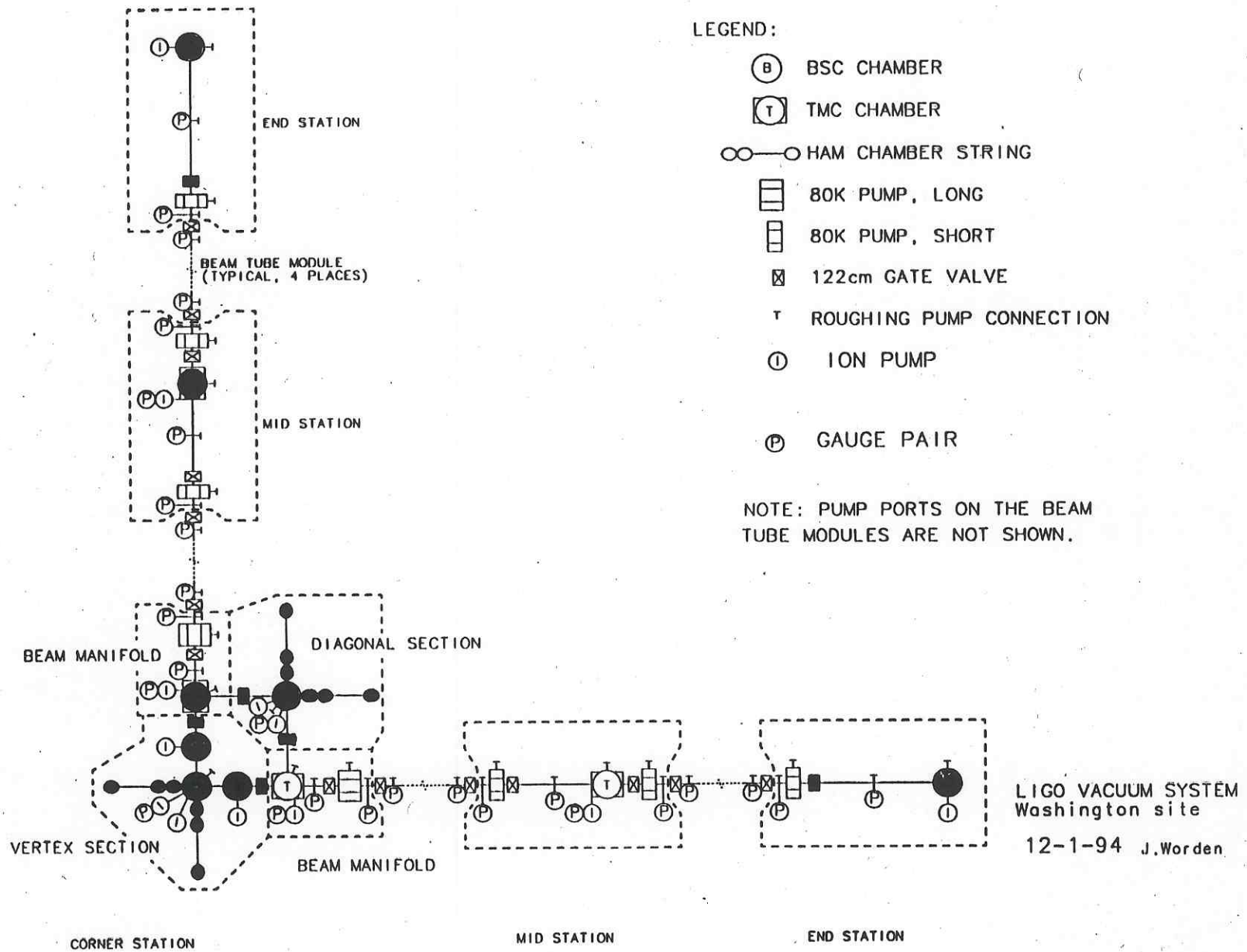
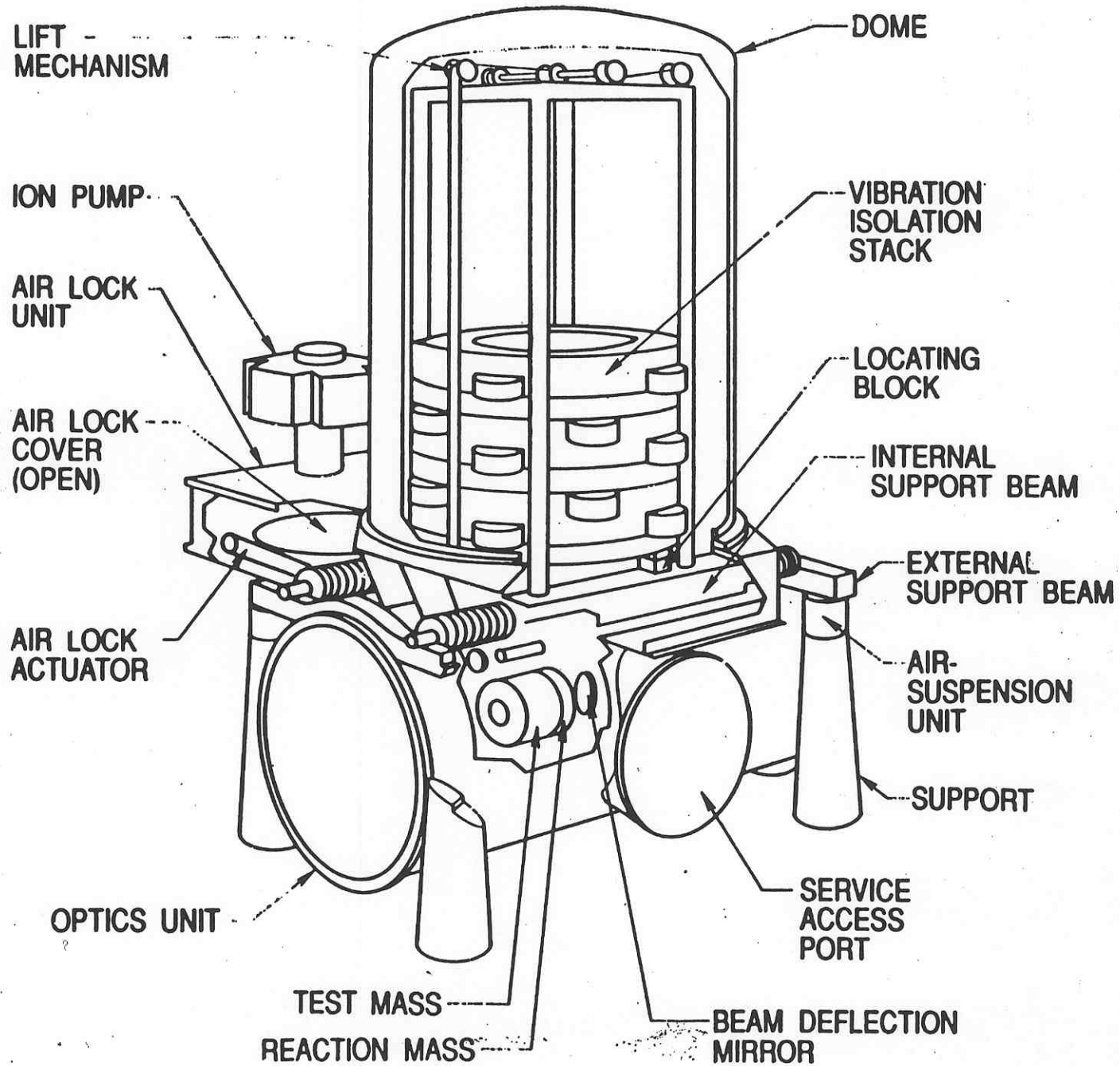
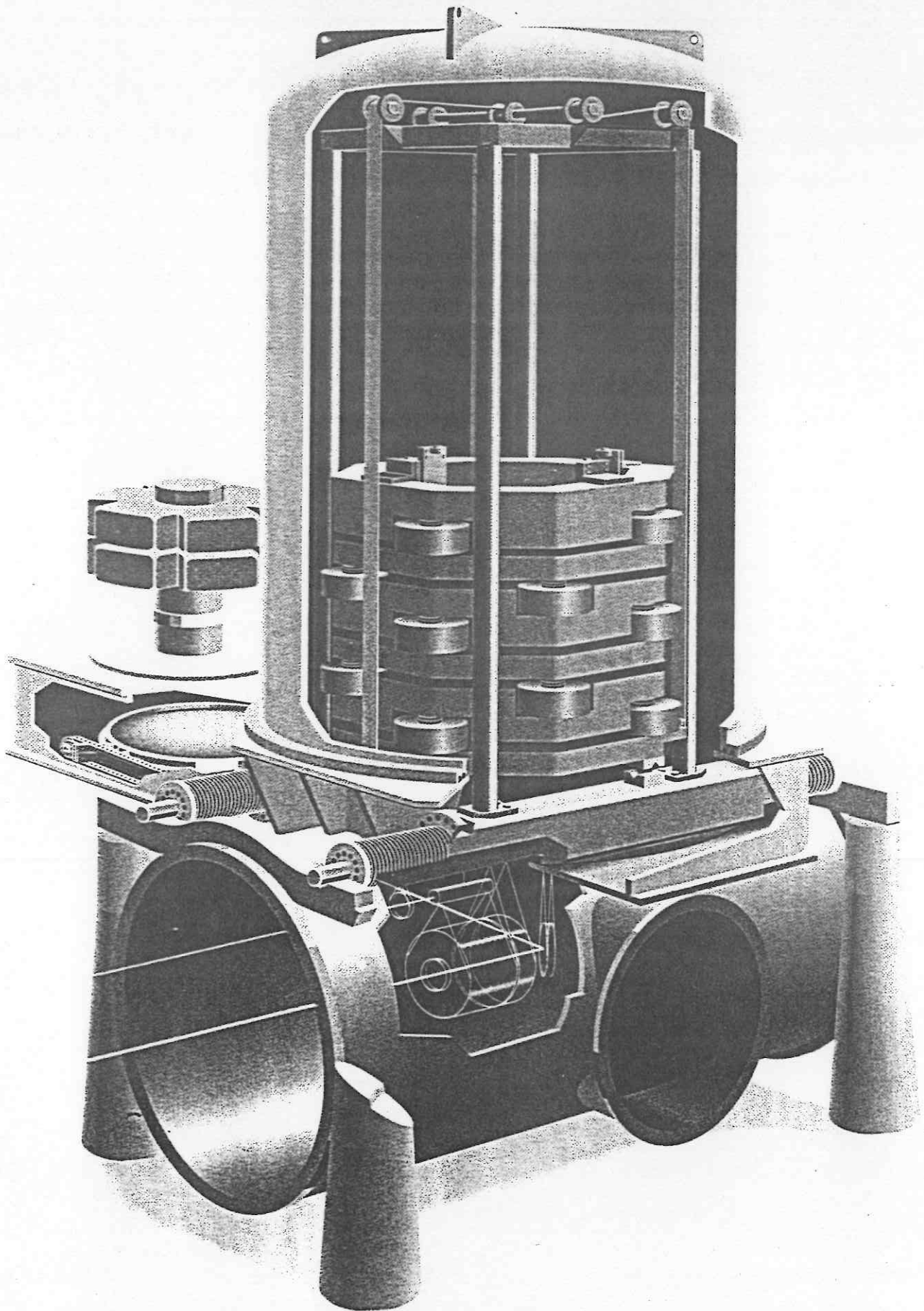
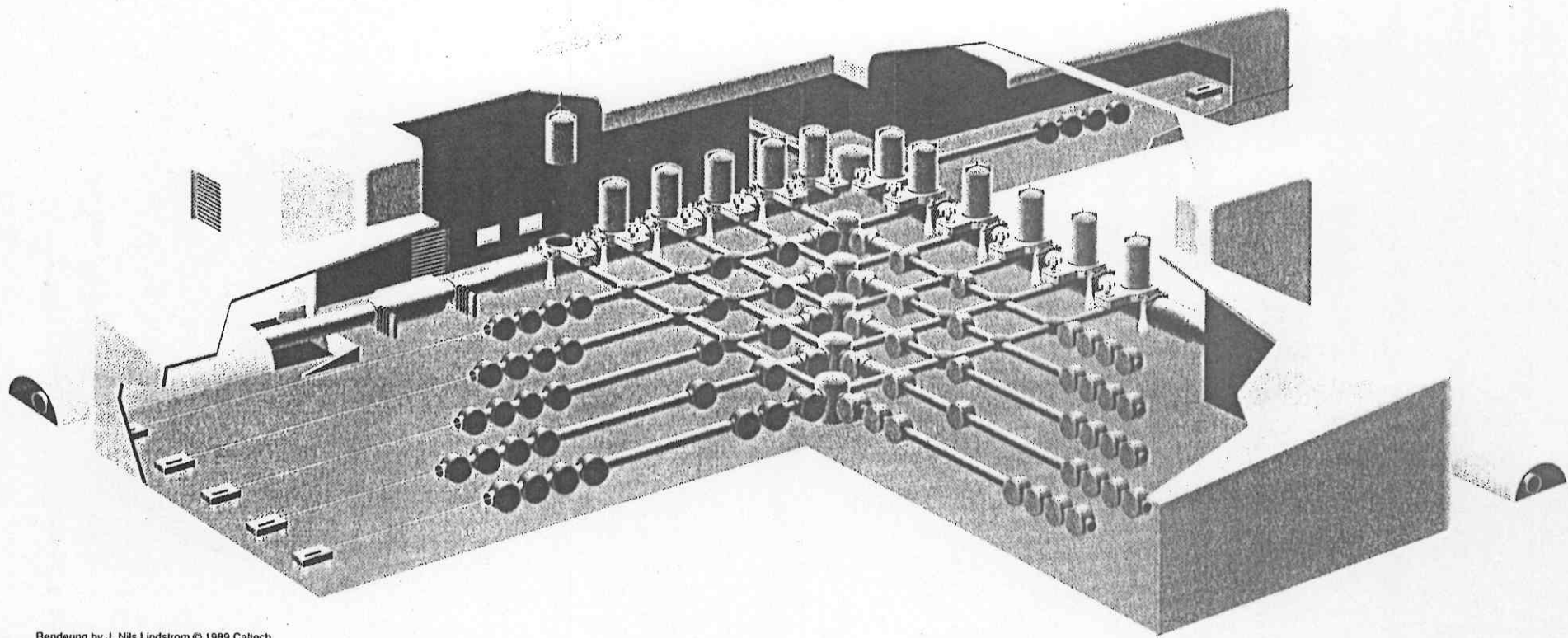

Figure 2.







Rendering by J. Nils Lindstrom © 1989 Caltech

## Residual Gas Pressure

- Refractive Index Fluctuation Noise
  - General Theory
  - Measured Example
  - Consequence: Allowable Partial Pressures
- Focus:  $H_2$  and  $H_2O$ 
  - Beam Tube Conductance and End Pumping
  - Condensible vs. Noncondensable
    - \* Beam Tube  $H_2$  Driven by Station Outgassing
    - \* Beam Tube  $H_2O \sim$  Independent of Station



## EFFECT OF GAS MOLECULES ON OPTICAL PHASE

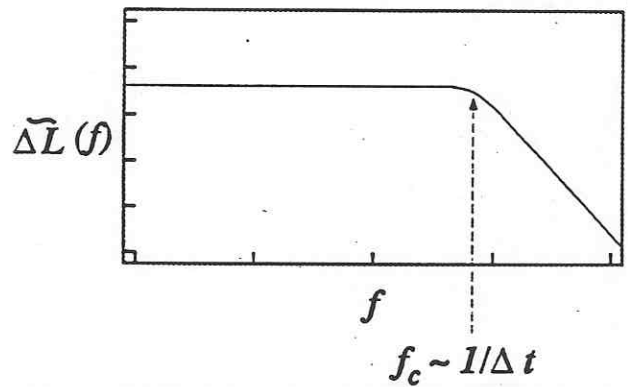
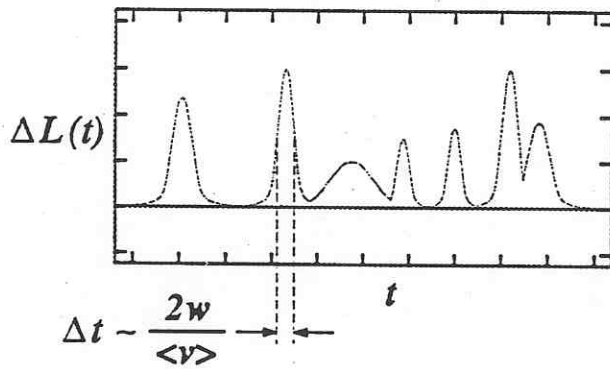
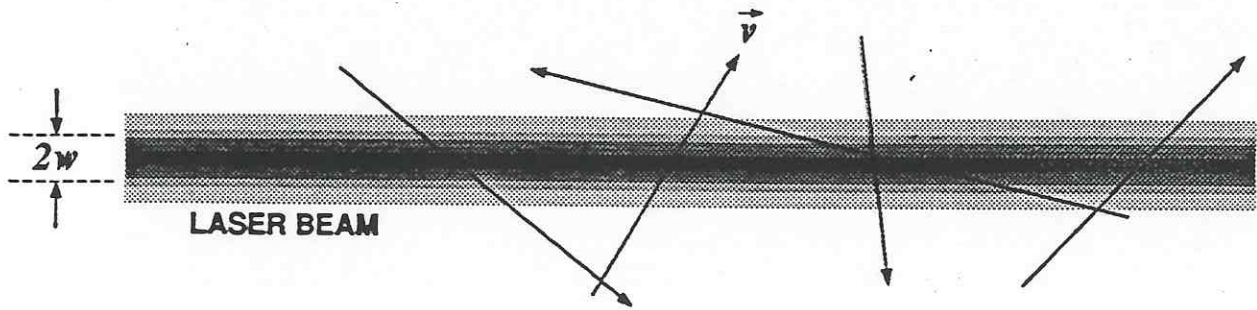

$$\Delta \tilde{L}(f) \propto P^{1/2} m^{1/4} \alpha \left( \frac{L}{w} \right)^{1/2}$$

where  $P$  is the partial pressure of the gas,  
 $\alpha$  is its molecular polarizability, and  
 $m$  is its molecular weight.

For diffraction-limited optical systems  $w \propto L^{1/2}$  so strain noise

$$\tilde{h}(f) = \Delta \tilde{L}(f)/L \propto L^{-3/4}.$$



# Residual Gas Index Fluctuation Noise

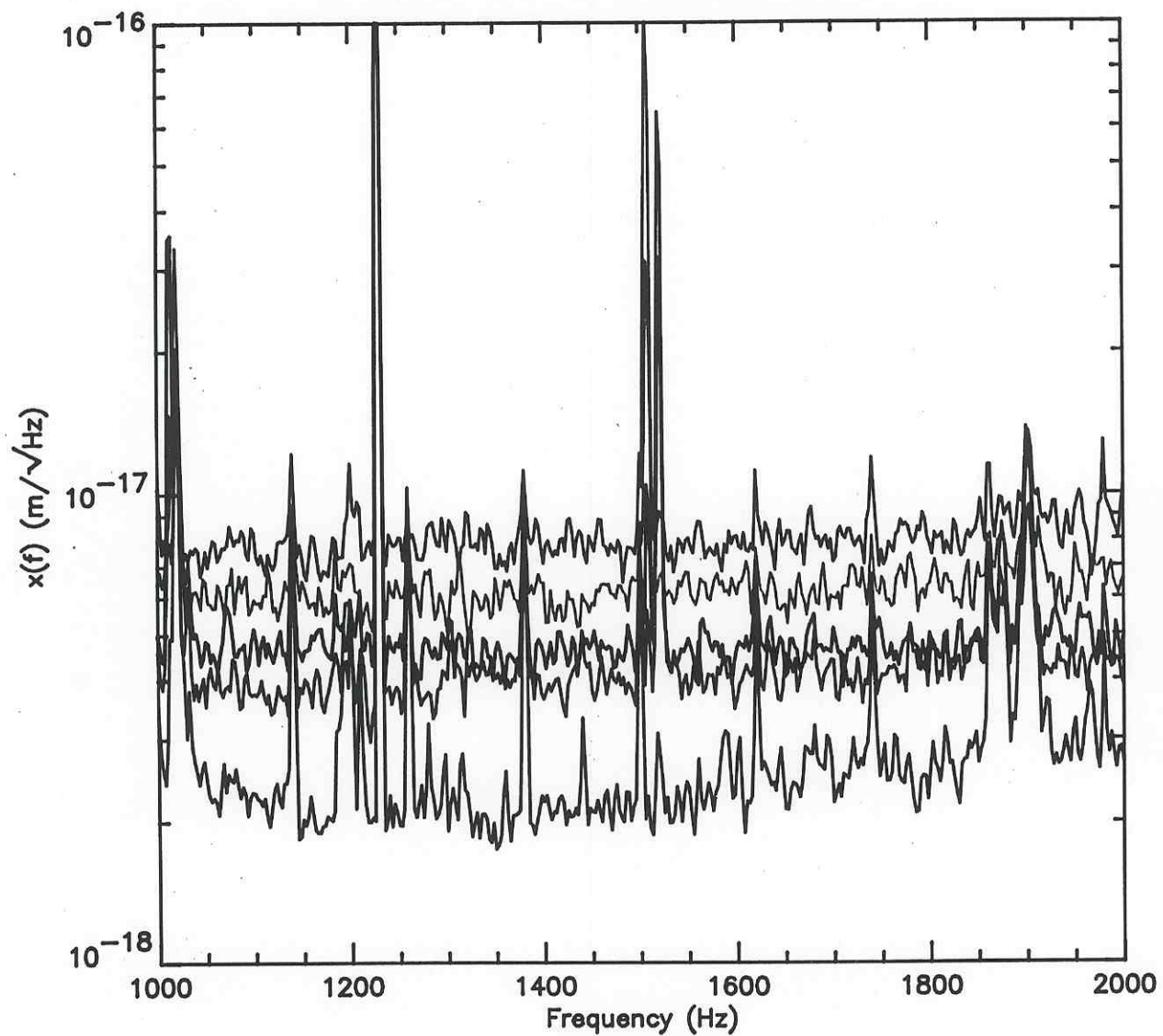
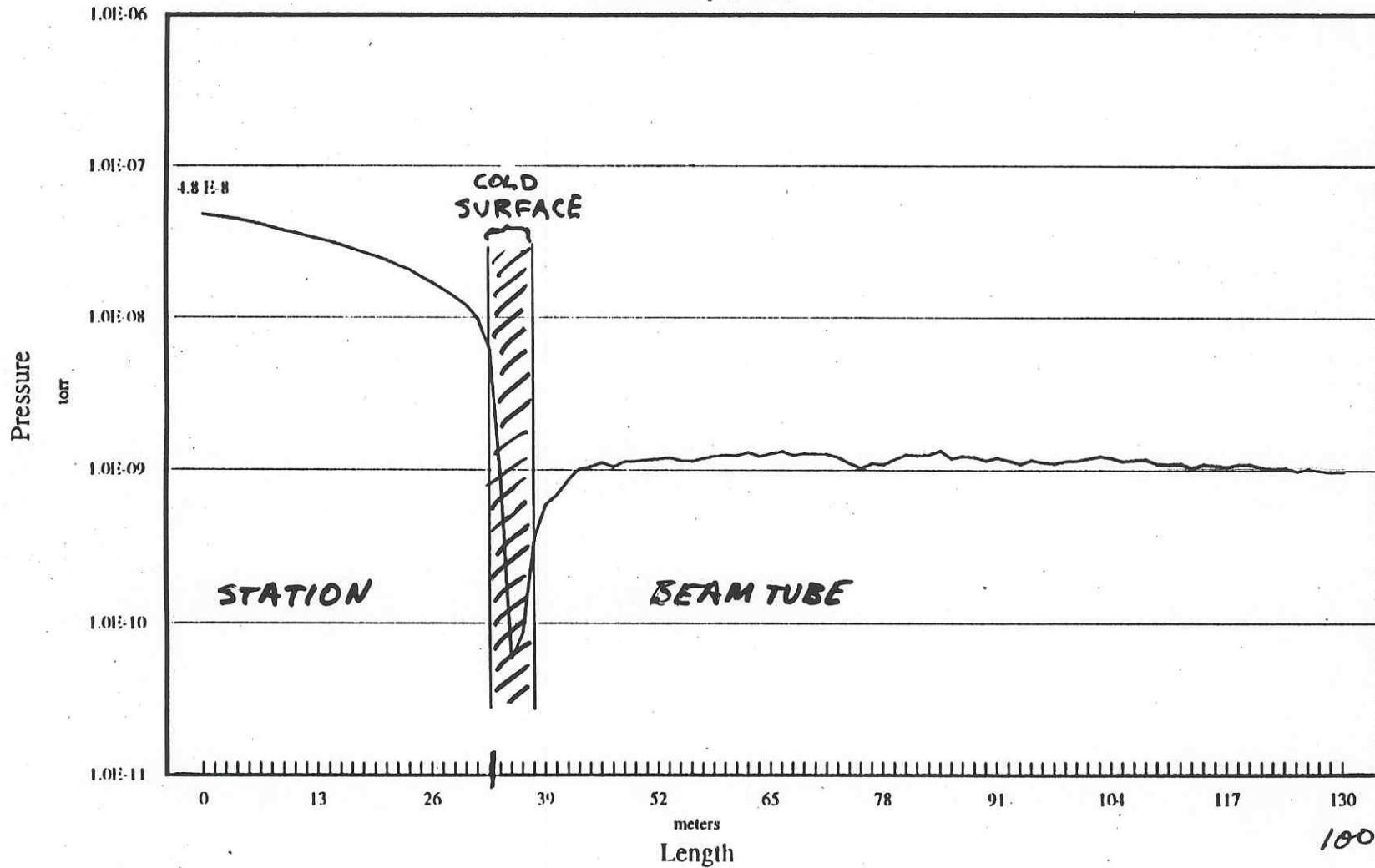

Table 1 Maximum allowable residual gas partial pressures for each section, after conditioning procedures described in text. Measurements are to be taken with ion pumps operating, and with the section under test exposed to operating 80 K pump.

Gas Species	Partial Pressure - torr
H <sub>2</sub> O	$5 \times 10^{-9}$
H <sub>2</sub>	$5 \times 10^{-9}$
N <sub>2</sub>	$5 \times 10^{-10}$
CO	$5 \times 10^{-10}$
CO <sub>2</sub>	$2 \times 10^{-10}$
CH <sub>4</sub>	$2 \times 10^{-10}$
All others	$5 \times 10^{-10}$

# Pressure Distribution

LN2 Pump (12 ft)



Pump is from 33.6 to 37.2 m  
Q(gas load) is .001 tl/s

100

# 40 m arm storage times

~robert/mark2/ringdwn/doarms

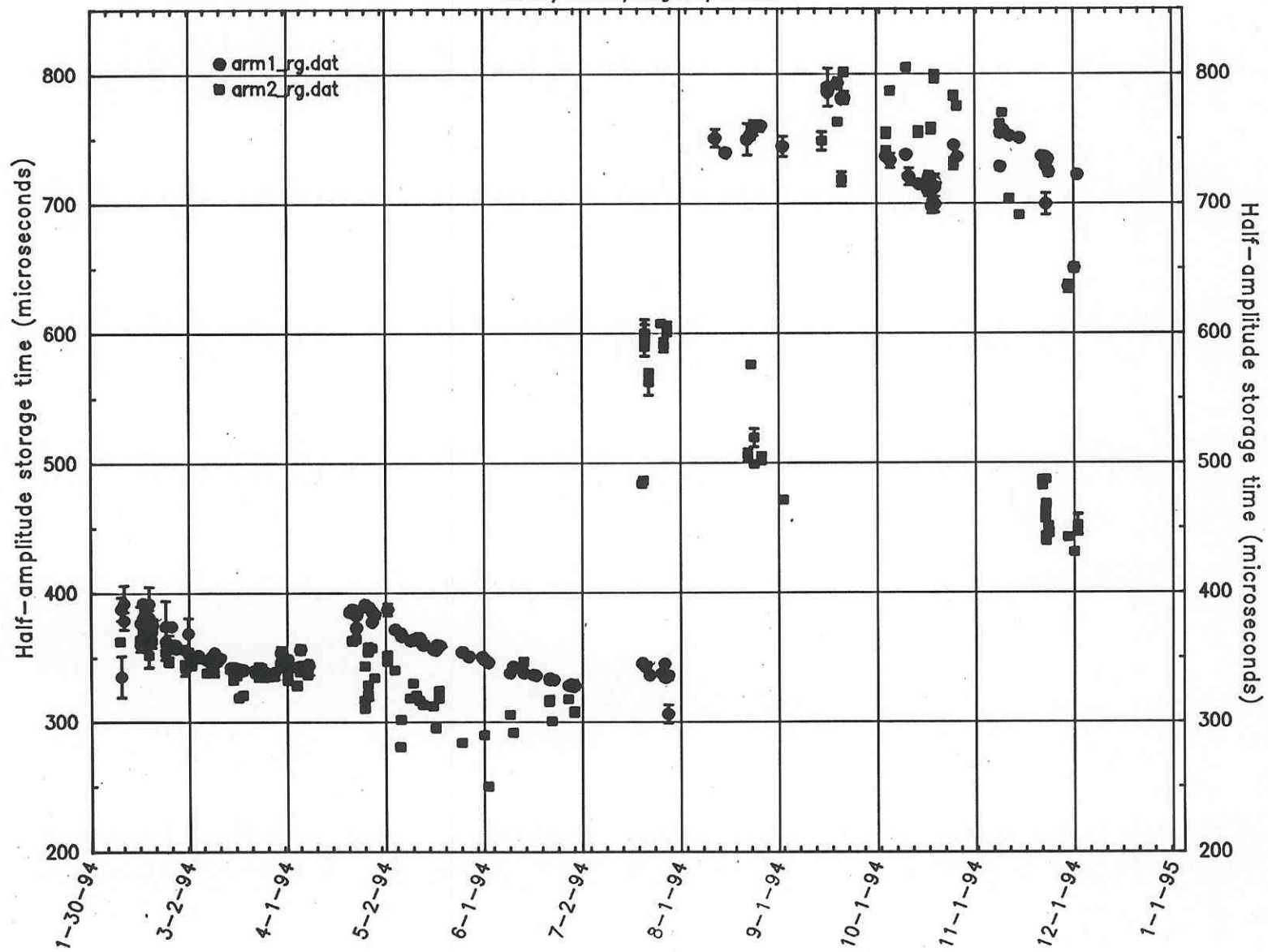

## Special Environmental Constraints

- Particle generation
- EMI
- Shock, Vibration & Acoustics
  - Main Concern: Normal Operations (ion/getter, 80 K pumps)
  - Added Feature: Quiet Turbopumping  
*Main Impact: Observing Operations and Availability*
  - Shock Limit: Prevents “Irreversible” Misalignment

# Corner Station North Axis, Morning Traffic December 13

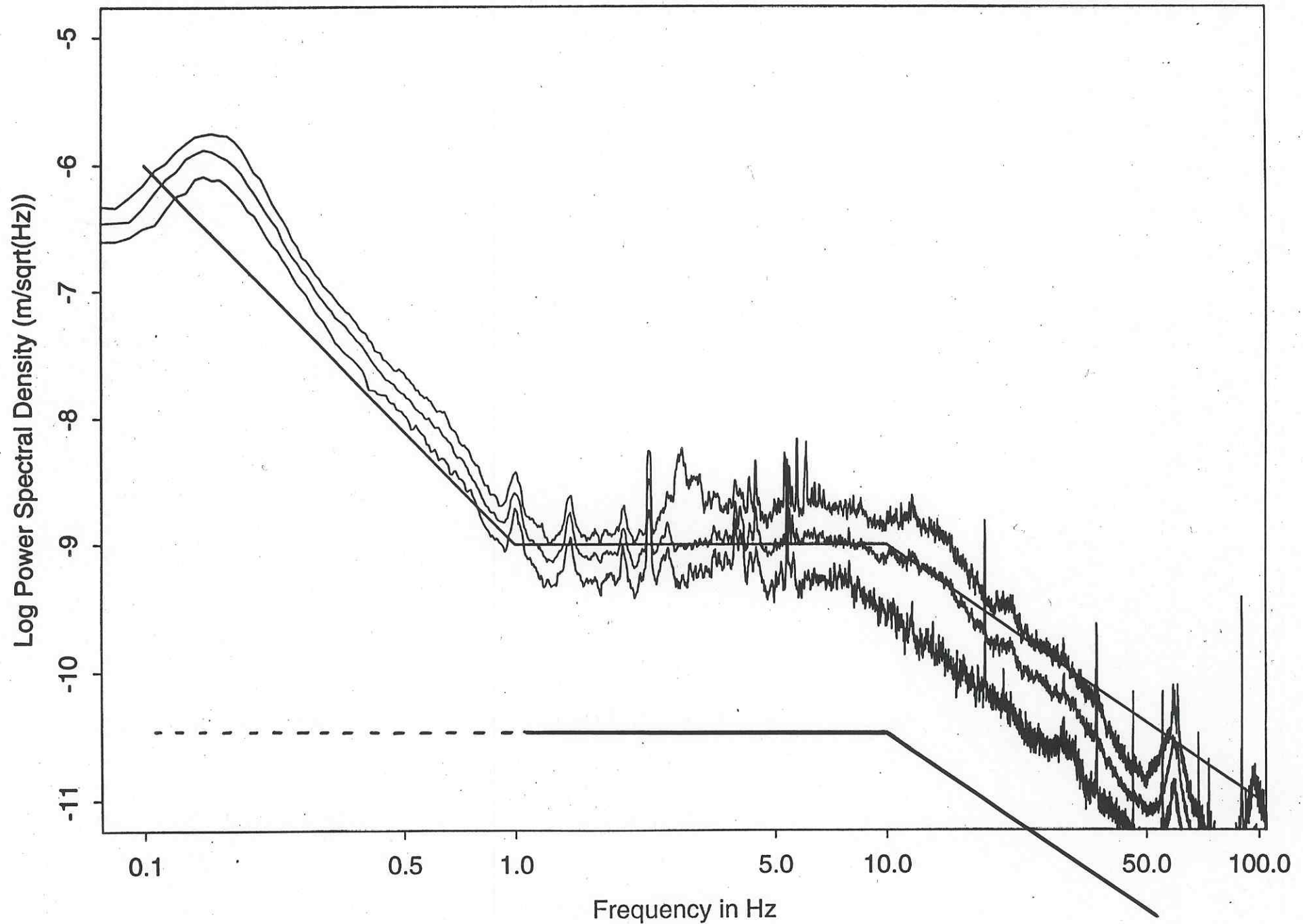



# Corner Station North Axis, Late Night December 12

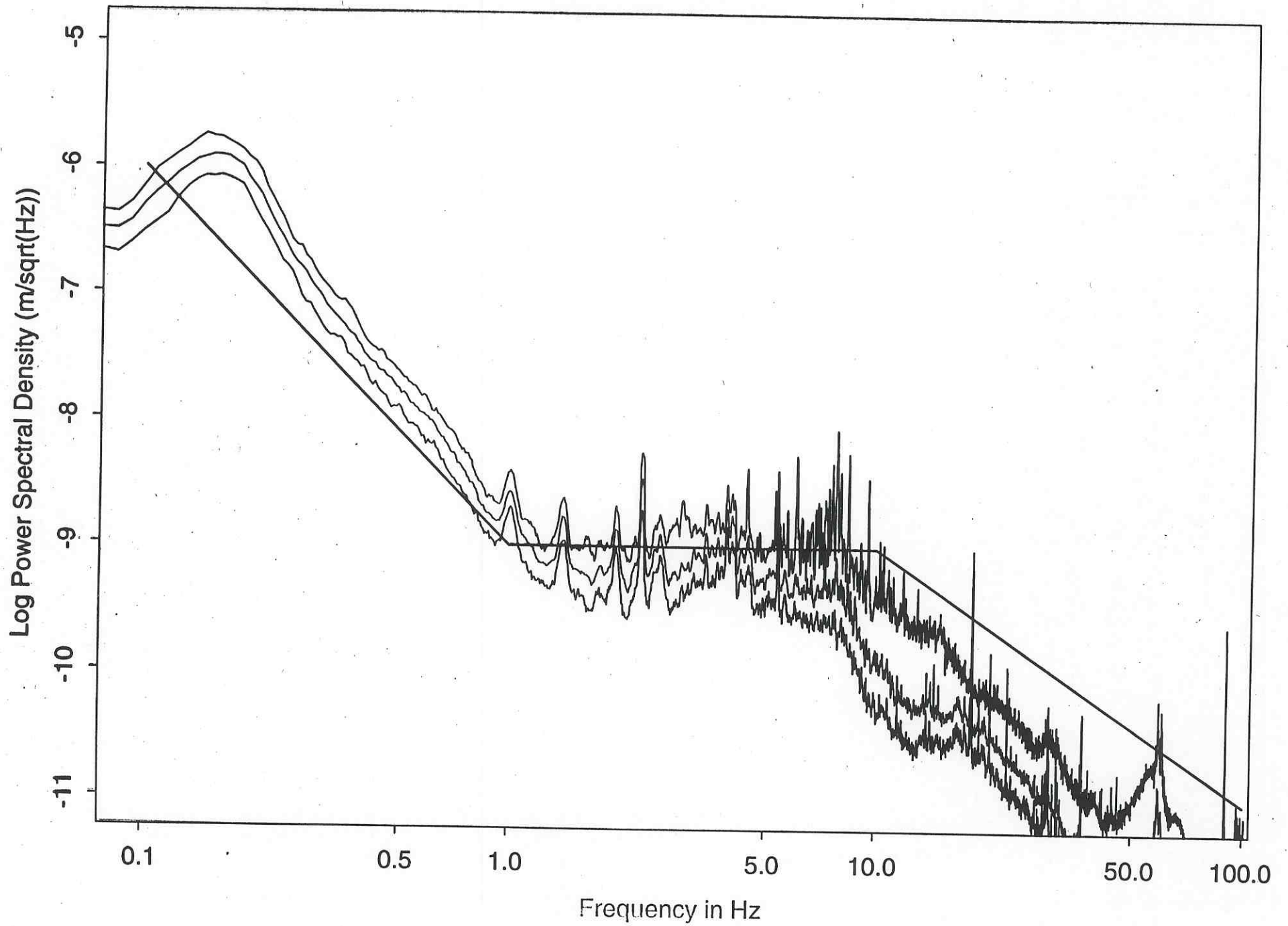

## Operations

- Operating Phases
  - Installation & Commissioning
  - Observing Operations
  - Detector Service and Upgrades
- Cycling Scenarios

Operating Phase	Under Vacuum (typ.)	Vented (typ.)
Commissioning	1 month	2 weeks
Observing	> 1 year	< 1 week
Upgrade	3 months	3 weeks

Table 1: *Anticipated vent/pumpdown frequencies and durations during different phases of observatory operations. Preliminary, subject to revision.*

- Tolerable Interruptions & Downtime in Observing Phase:  
*No more than 1/2 day per month (TBR) allotted for required maintenance, e.g. trap regeneration, which disables detector by blocking beam tube, causing elevated vibration levels, etc.*

(b) 20cm OD TUBE PORTS  
ON 152cm DIA. CIRCLE

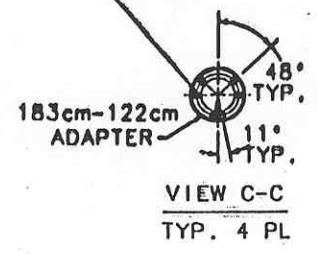

DIMENSIONS ARE SHOWN FOR RIGHT ARM.  
LEFT ARM DIMENSIONS ARE IDENTICAL,  
MIRRORED ABOUT THIS 45 DEGREE  
BISECTOR

46 m 82 cm

BSC (DWG. 1101009), 4 PL

152cm DIA. X 90cm(minimum)

HAM (DWG. 1101010), 12 PL

76cm ID MODE  
CLEANER TUBE

1 HAM CHAMBER  
NOT SHOWN

PLAN VIEW

LONG LN2 PUMP

183cm DIA. BEAM  
TUBE MANIFOLD

13 m 72 cm  
(TYP., 2 PL.)

27 cm

1 m 77 cm

ELEVATION VIEW

