



---

# H1 Squeezer Review

Review Meeting,  
August 19, 2008

ANU, AEI, MIT, CIT and LHO

Sheon Chua, Ping Koy Lam, Harald Lück, Nergis Mavalvala, David McClelland,  
Roman Schnabel, Daniel Sigg, Henning Vahlbruch and Stan Whitcomb

# Motivation

---

- ❑ High power operation in future detectors
  - Biggest remaining technical risk (after DC readout)
  - Squeezing allows for lower laser power
- ❑ Squeezer technology now ready
  - 7 dB of squeezing down to 10 Hz
  - Has been demonstrated on a bench and on interferometers (40M)

## **Missing: Low frequency noise demonstration**

- ❑ Planned Experiments
  - GEO600: prototype for long baseline interferometers
  - Hanford H1: low noise at low frequency

# Goal of the H1 Squeezer Experiment

---

- ❑ Demonstrate squeezing at low frequency with a high sensitive long baseline interferometer
  - Demonstrate 3 dB of squeezing at frequencies where we are shot noise limited
  - Do not introduce noise at other frequencies!
- ❑ Build a squeezer which could be readily turned into an advanced LIGO upgrade
  - Fully engineered optical breadboard
  - Use LIGO type electronics and controls
  - Prepare for long-term reliability investigations
- ❑ Be ready for a test on H1 after S6

# Squeezed Enhanced LIGO, 30 W

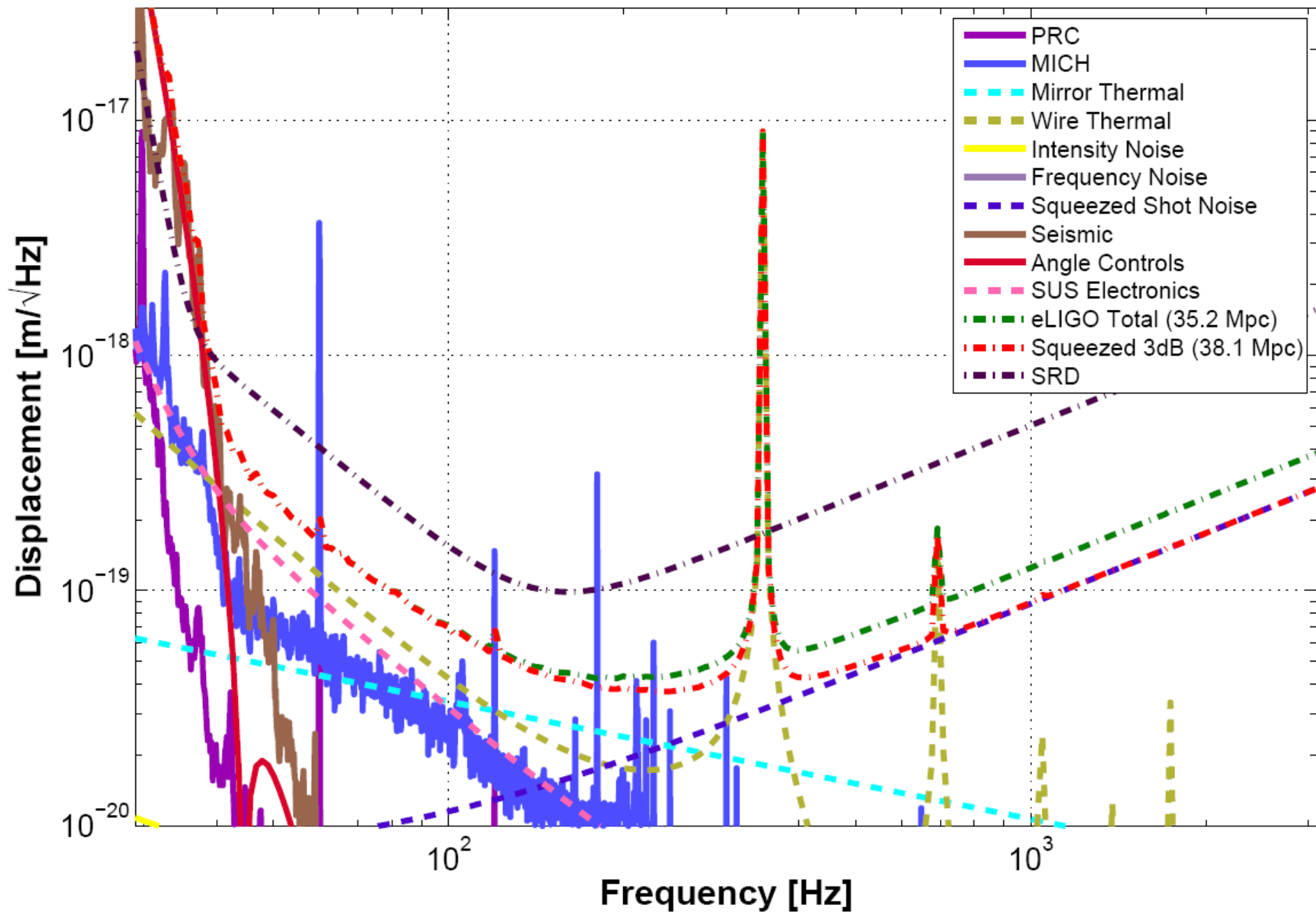

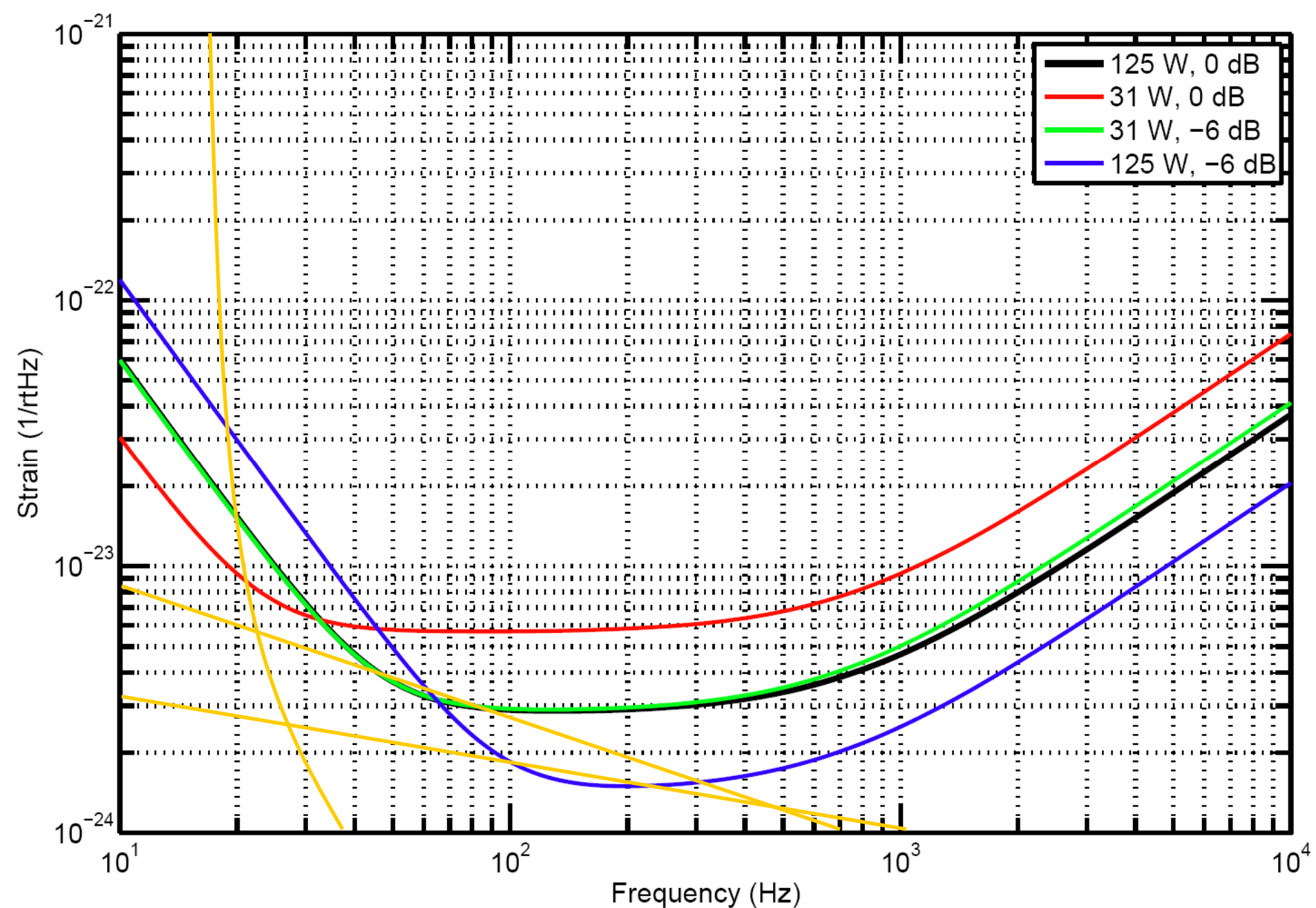

# Baseline Design

---

- ❑ Inject into HAM4
  - SQT4 opposite of ISCT4
  - New advanced LIGO Faraday design
- ❑ Optical breadboard 5' x 3'
- ❑ 1W frequency double Nd:YAG laser
  - Locked to interferometer laser by fiber
- ❑ Auxiliary laser for frequency shifted subcarrier
- ❑ Optical parametric oscillator (OPO)
  - Doubly resonant
  - Bowtie configuration
  - Non-linear crystal: PPKTP

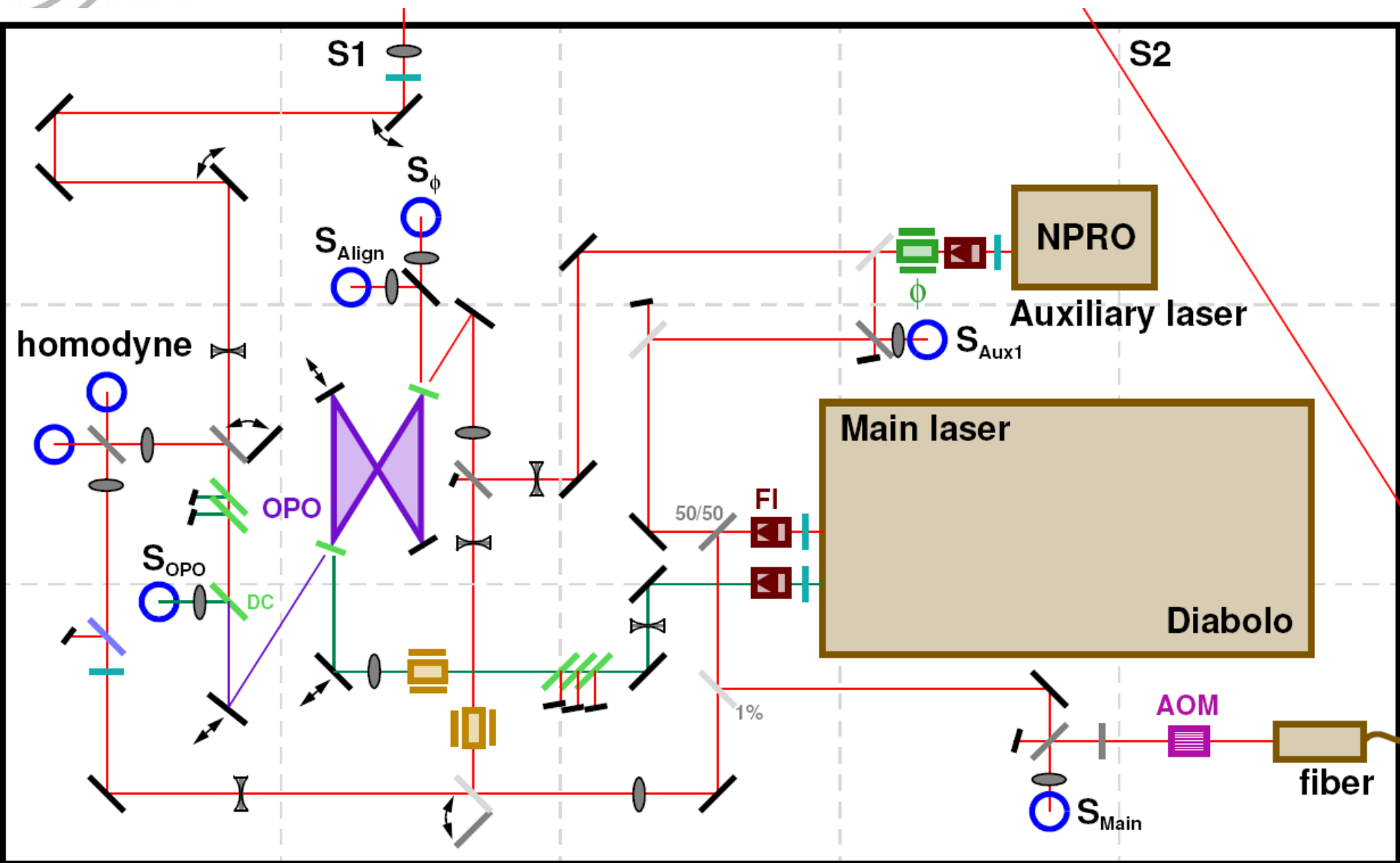

# Servos

---

- ❑ Fiber stabilization: Feed forward
- ❑ Main laser offset-locked to probe beam
  - Use initial LIGO FSS
  - Pockels cell & PZT & thermal actuator
- ❑ Auxiliary laser offset-locked to main laser
- ❑ OPO: PDH on green light
  - PDH on probe beam at carrier frequency for alignment
- ❑ Squeezer phase & LO phase
  - Subcarrier sensing
  - Feedback to PZT mirror in green and squeezed light paths
- ❑ Homodyne detector for verifying squeezing



# Electronics Setup

---

- ❑ Compensation networks too fast for digital servos
  - Look-and-feel of a PSL system
- ❑ Remote controls: EtherCat from Beckhoff
  - Same as in Advanced LIGO laser
  - EPICS interface through OPC server
  - Can be used stand-alone with a PC or control panel
- ❑ LIGO electronics wherever possible
  - FSS, CM/MC board, RF distribution, demodulator, phase shifter, ...
  - PZT actuators from Physik Instrumente
  - No WFSs!

### Fiber Locking

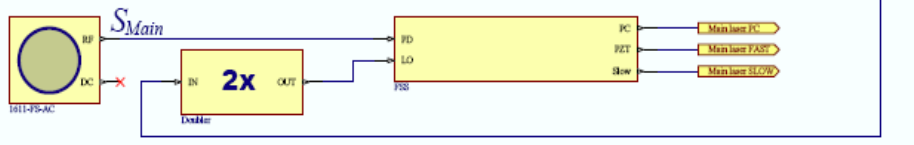
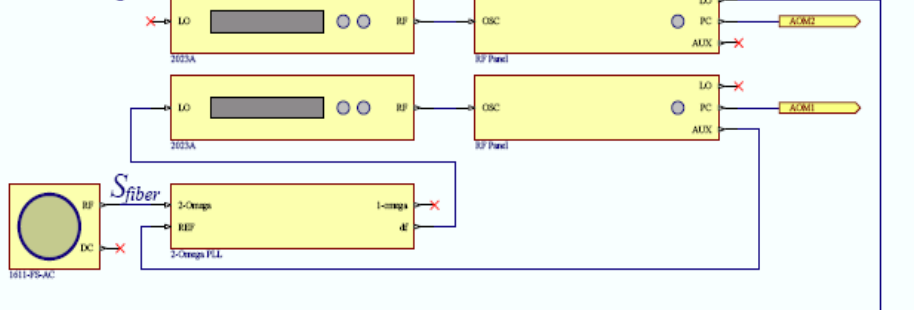

### Main Laser Locking

### OPO Locking

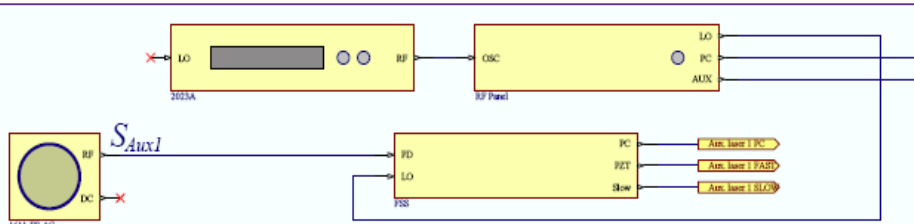
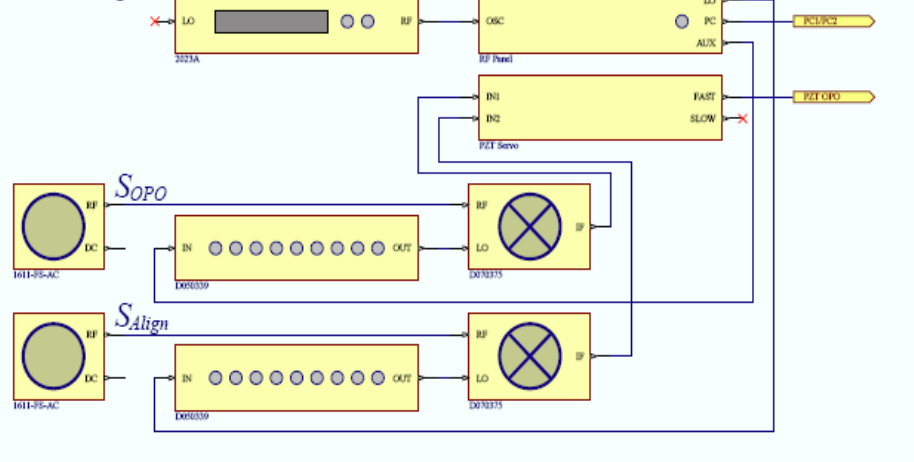

### Auxiliary Laser 1 Locking

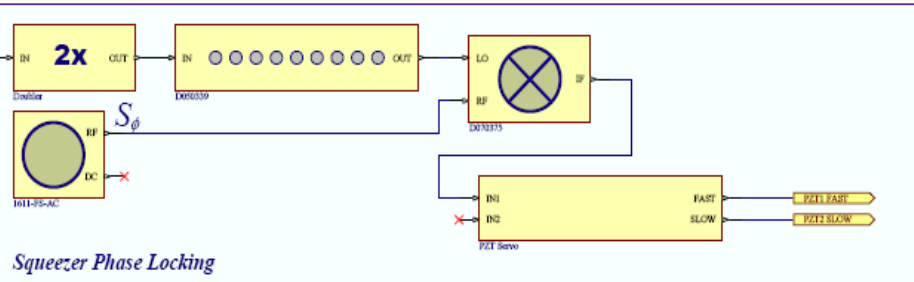

### Squeezer Phase Locking

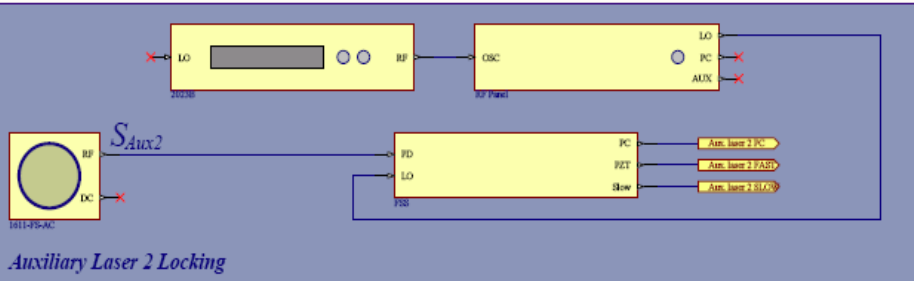

### Auxiliary Laser 2 Locking

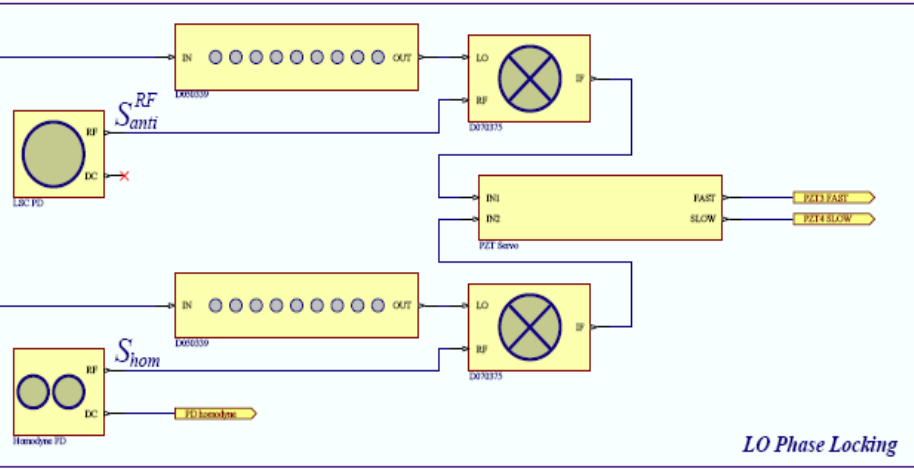

### LO Phase Locking

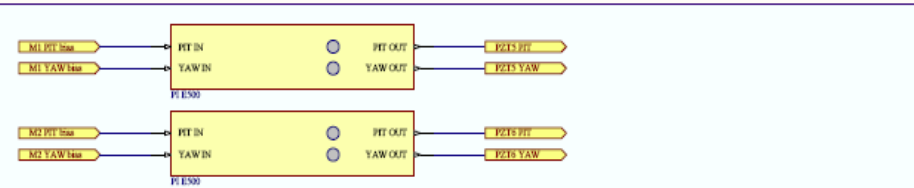

### Angular Control

# Technical Issues (1)

---

- ❑ OPO: see ANU presentation
- ❑ SHG
  - Diabolo laser system comes with an integrated SHG
  - Need to address internal scattering issues
- ❑ Auxiliary lasers
  - Scattering of AOMs too much trouble
  - Freedom to choose subcarrier frequency
  - A singly-resonant cavity would require a 2<sup>nd</sup> auxiliary laser to lock it
- ❑ Fiber stabilization
- ❑ In-vacuum AS-port Faraday isolator
  - Develop advanced LIGO unit

# Technical Issues (2)

---

## ❑ Scattering paths

- Inject opposite ISCT4
- Second in-vacuum Faraday isolator in injection path
- Baffling on the optical breadboard

## ❑ Long-term reliability

- Squeezer will be available after H1 experiment

## ❑ SQT4

- Reuse ISCT3
- Mount table high to avoid a periscope

## ❑ Initial Alignment

- Use rejected beam from Faraday in injection path as a fiducial

# HAM4 Layout

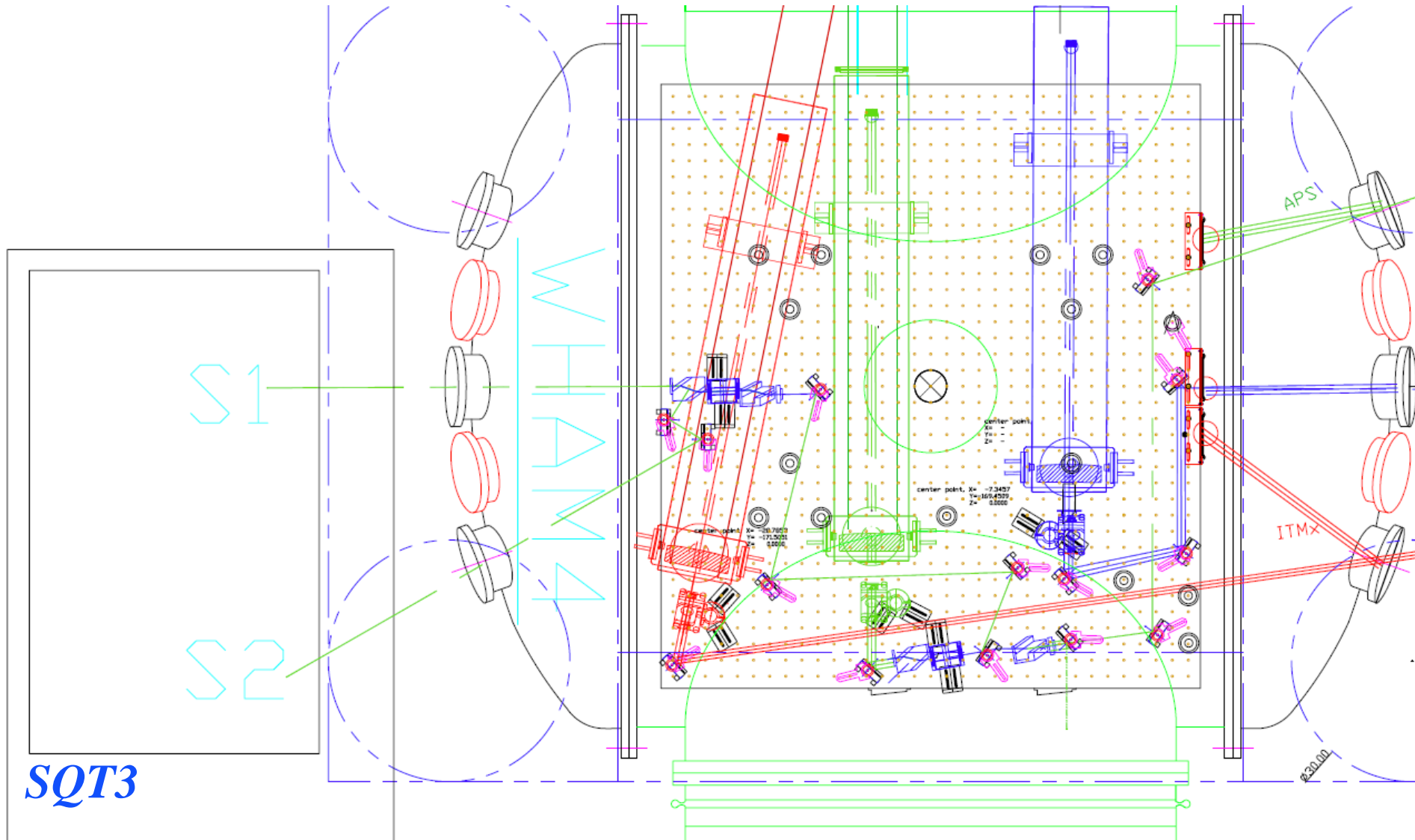



# Squeezing GEO600

Harald Lück



# Current GEO600 operation mode



- Dual recycling; detuned to 550Hz
- SR transmission 2%
- Heterodyne read-out 15MHz
- 3 kW inside PR cavity

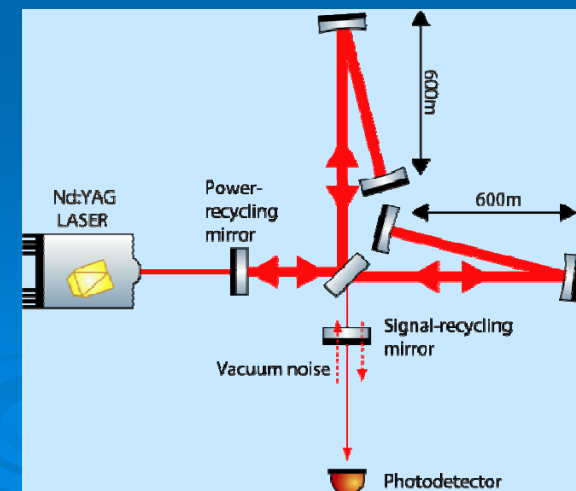

# Plans



- Astrowatch + low-risk commissioning until 'Enhanced' IFOs come online (spring 2009 )
- Keywords: DC readout, squeezing, OMC, higher power, thermal comp., tuned SR, lower SR factor, extended digital control...
- Goal: demonstration of long term stable operation of GEO-HF with squeezed light @ improved sensitivity

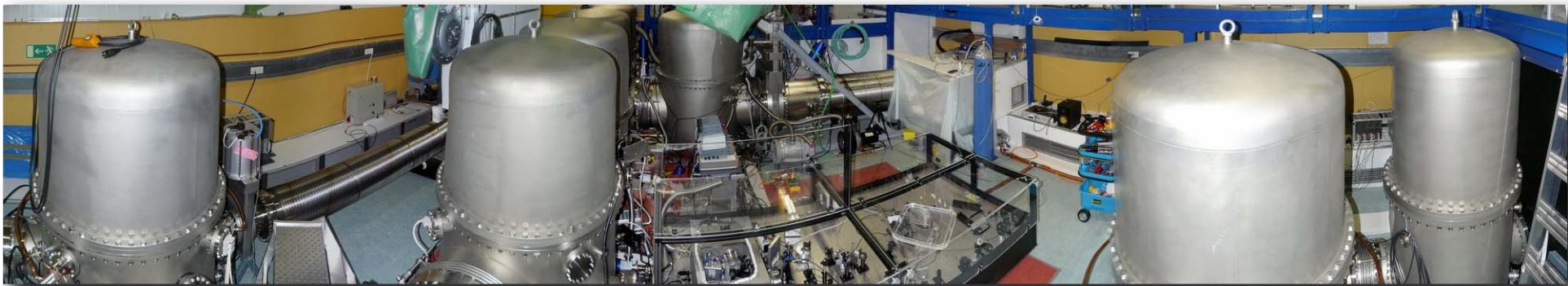



# GEO 600 optical layout

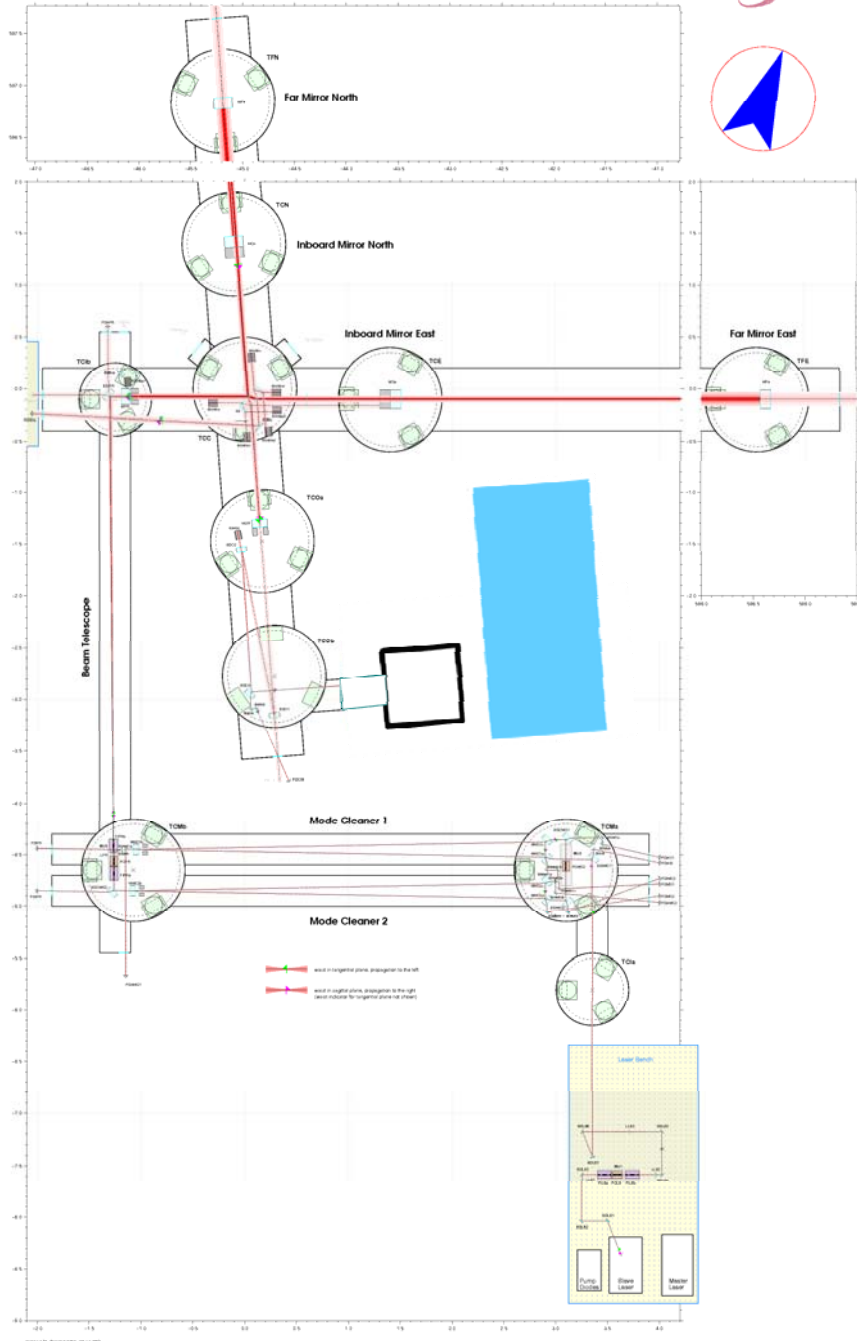

Now:

- Auto Alignment on detection bench
- Main photo detector on detection bench outside vacuum system



# GEO 600 optical layout

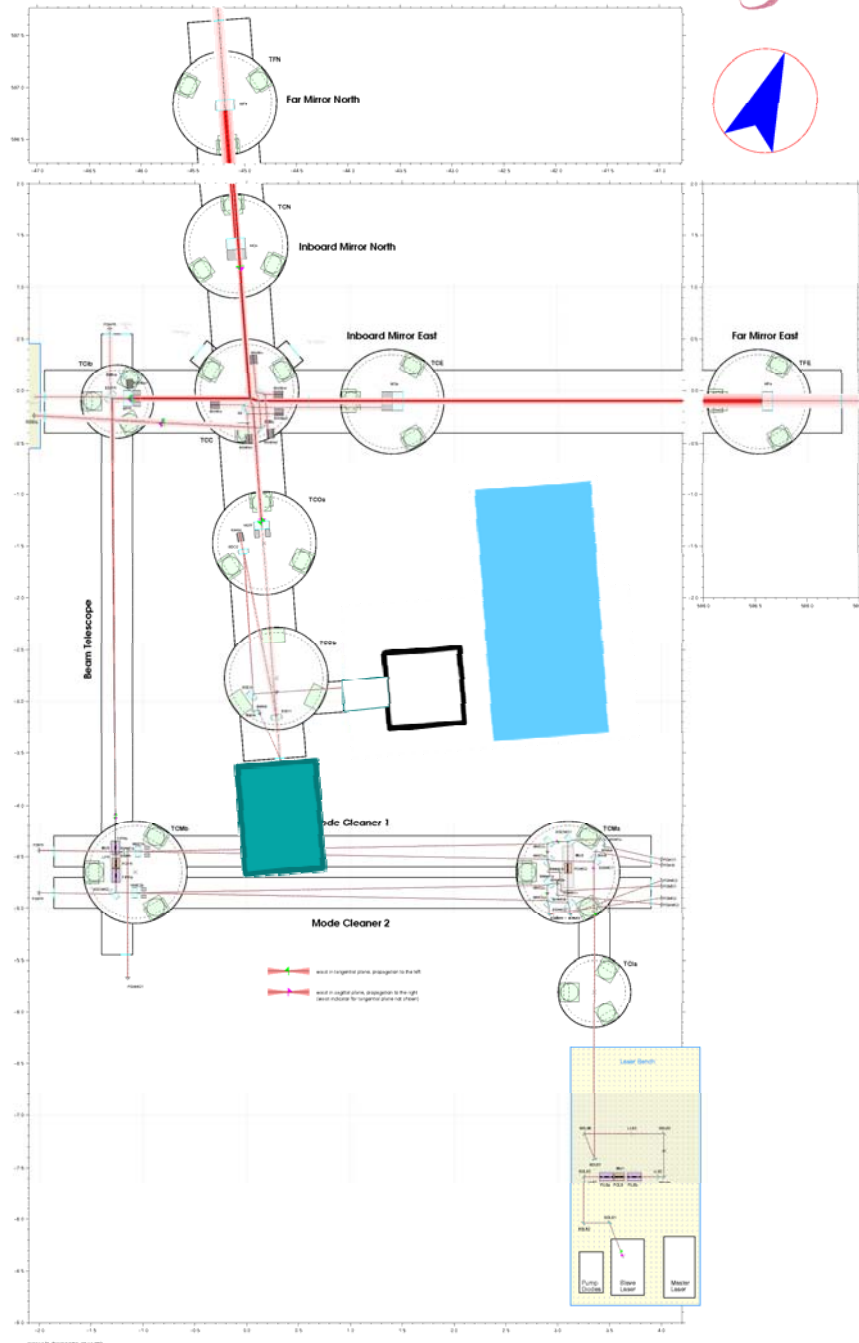

Then:

- Auto Alignment on new AA bench
- Main photo detector in additional vacuum tank
- OMC to reduce higher order TEM mode contributions to detected light
- > less technical problems with PD @ higher light levels



# Schematics of injecting squeezed light

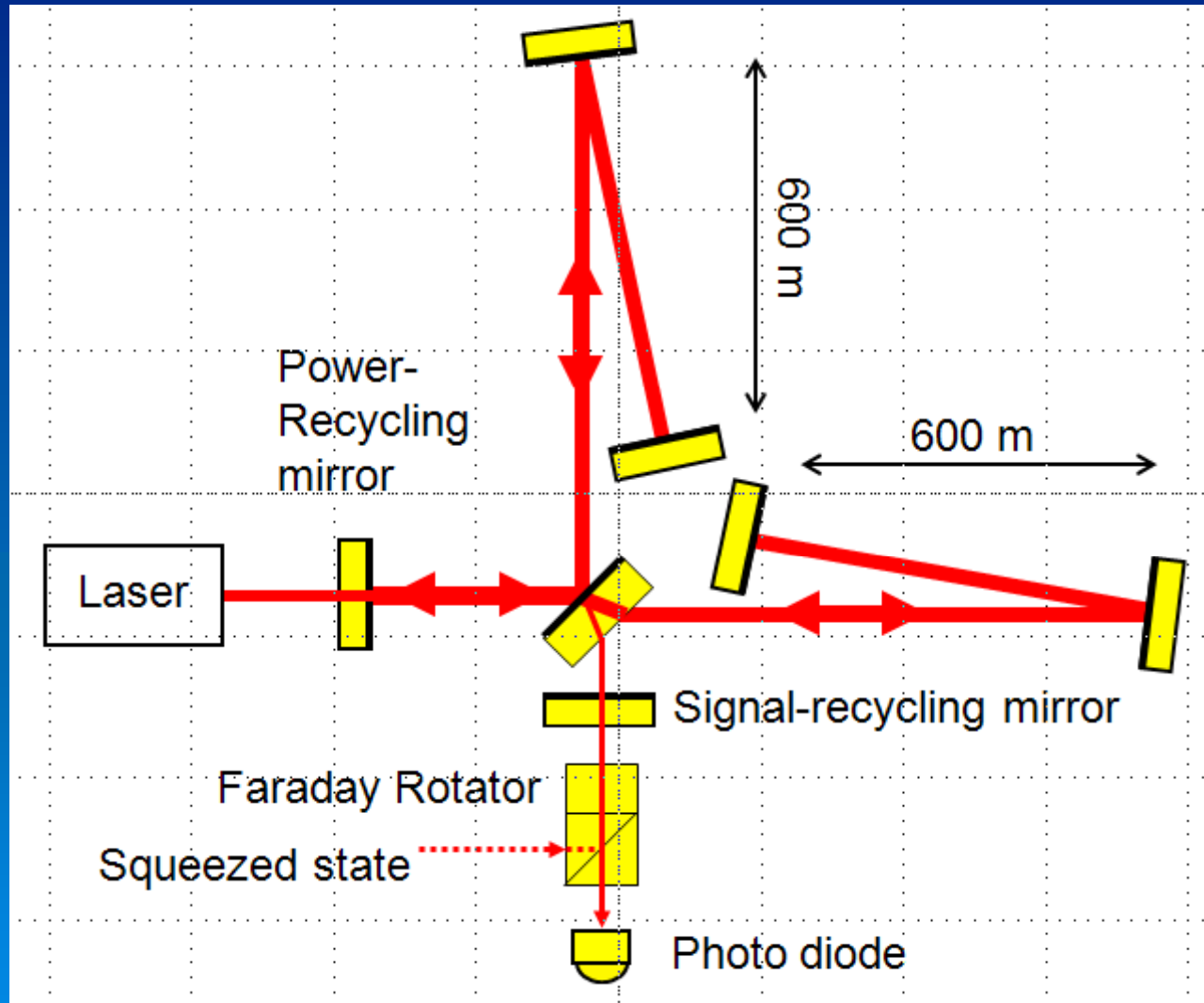



5

Details of injection scheme and control signal generation currently being investigated

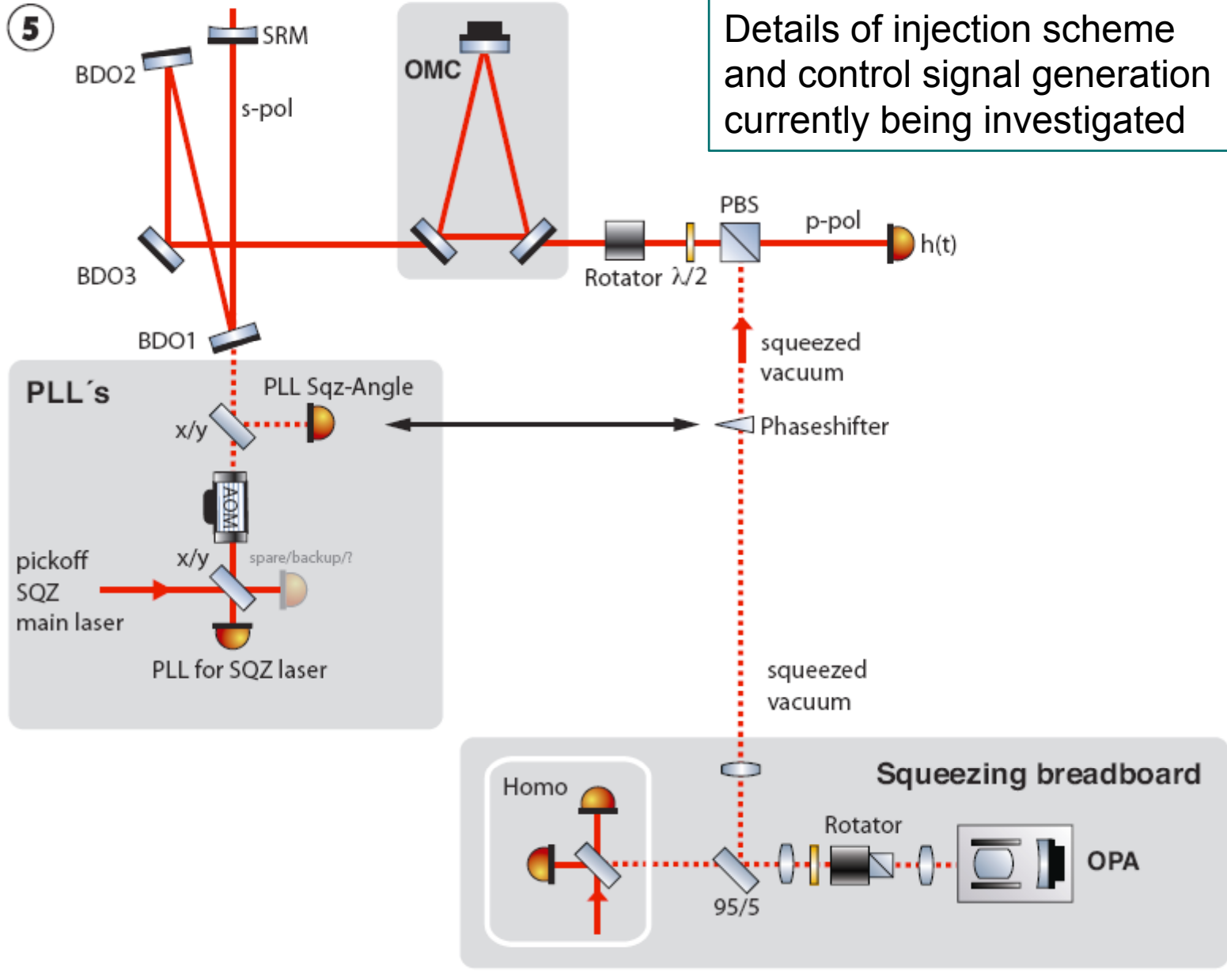

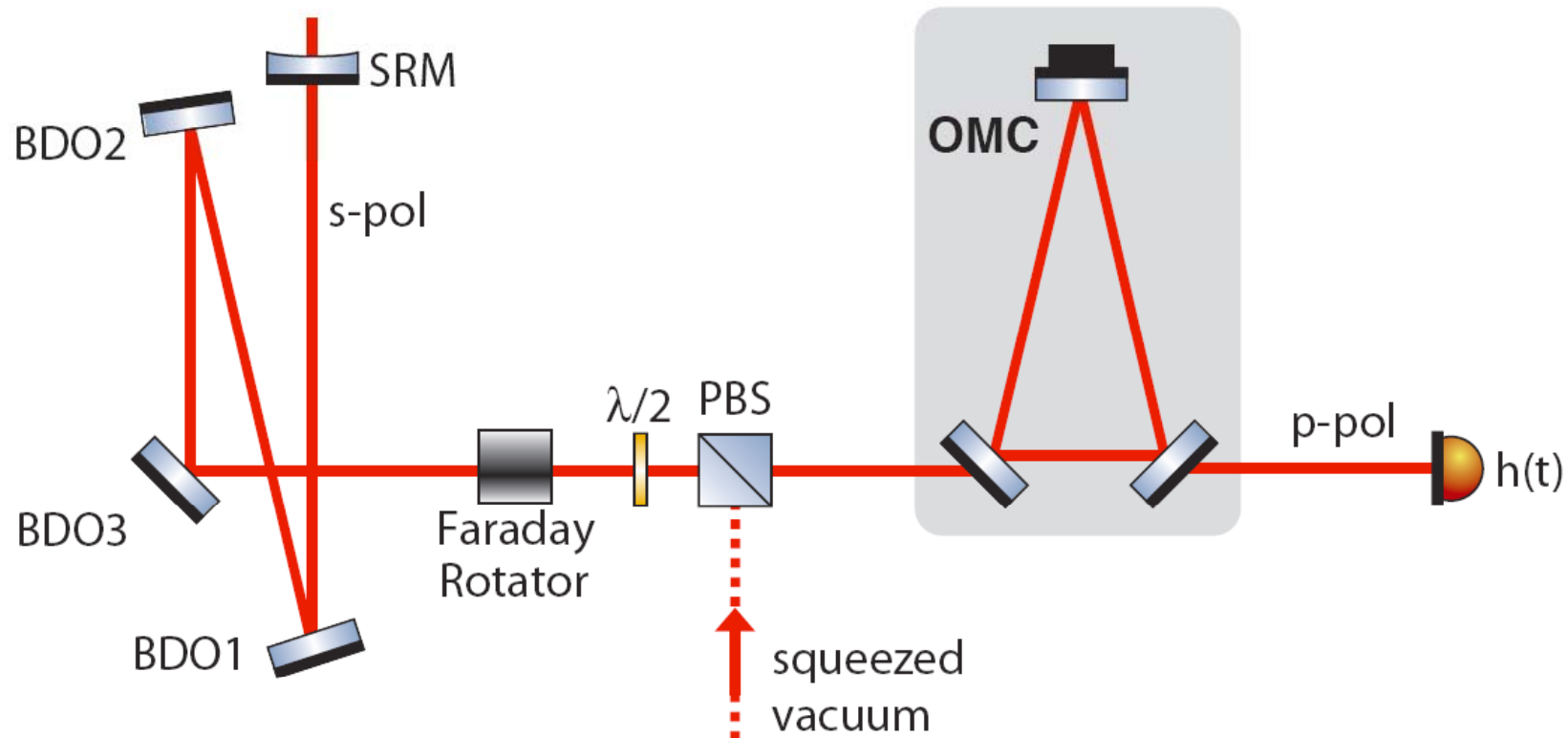

squeezed vacuum  
 Phaseshifter

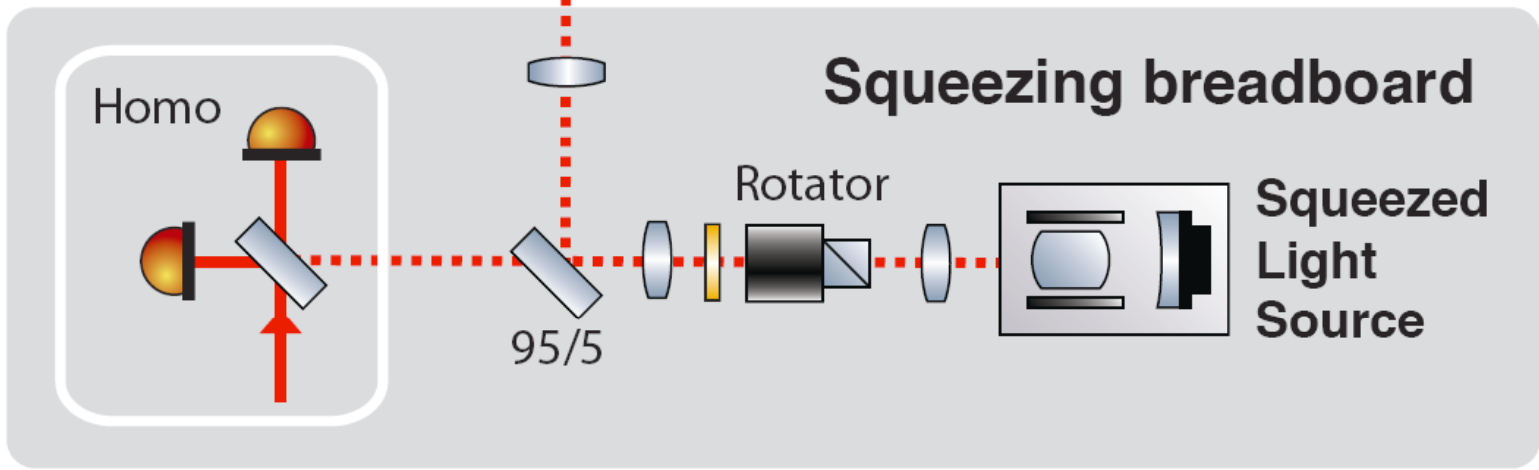

# Squeezed light and optical losses

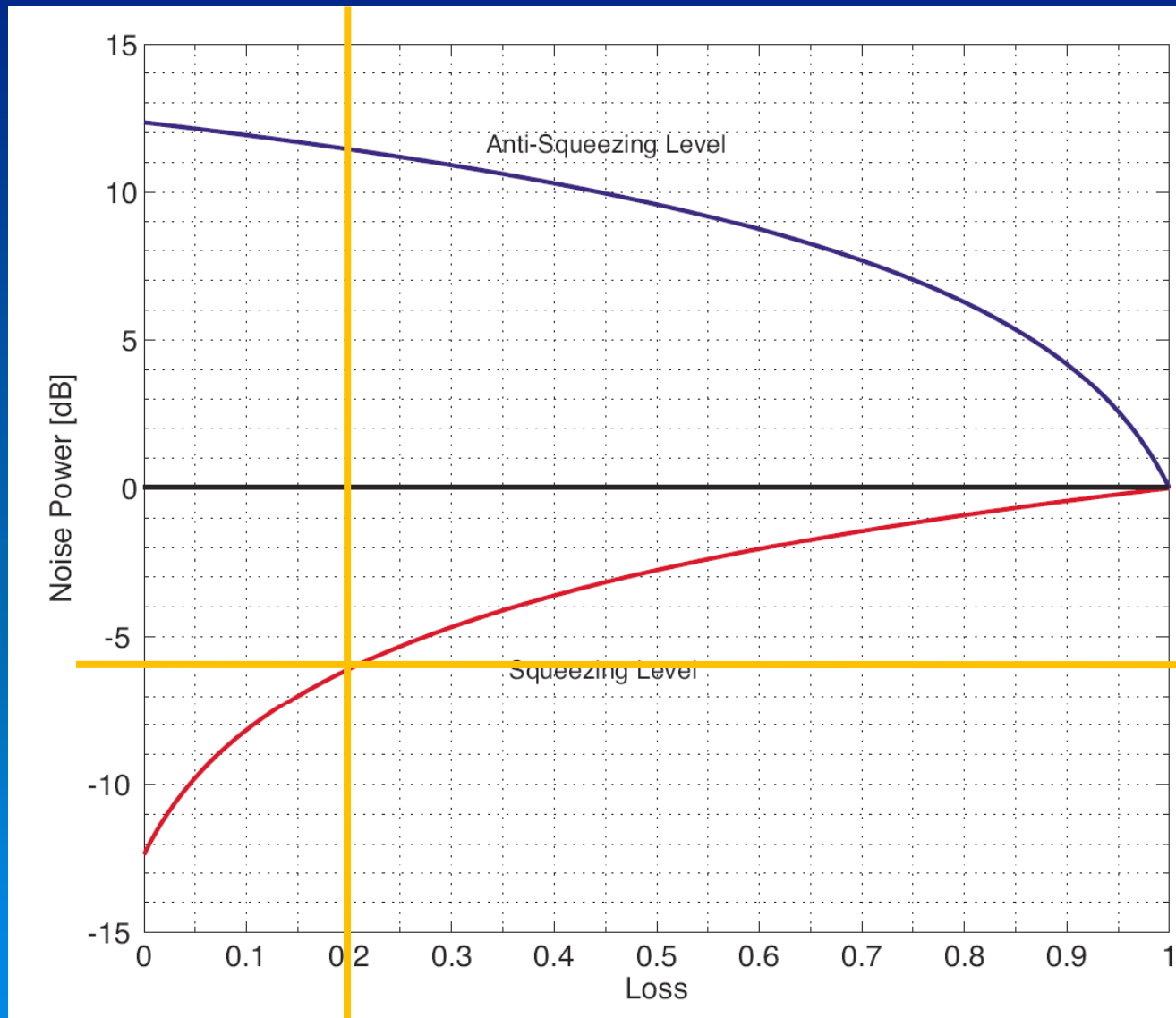

6 dB

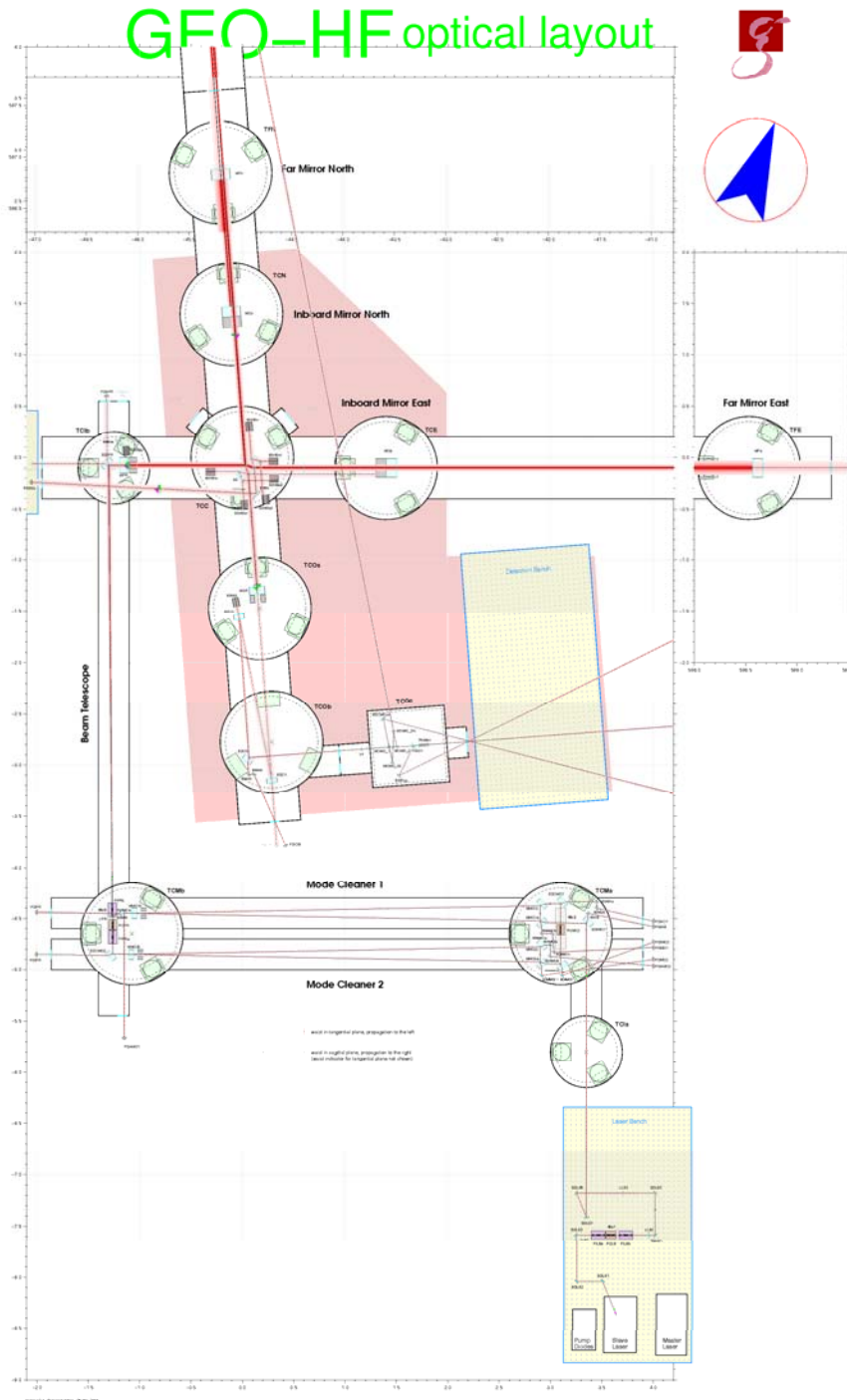

# Power increase

- Currently **3.5kW @ MPR**
- Increase laser power  
10 W (6 W) -> 35 W
- Exchange MC mirrors  
-> increase throughput 2x  
-> **30kW @ MPR**



# Options Towards GEO-HF

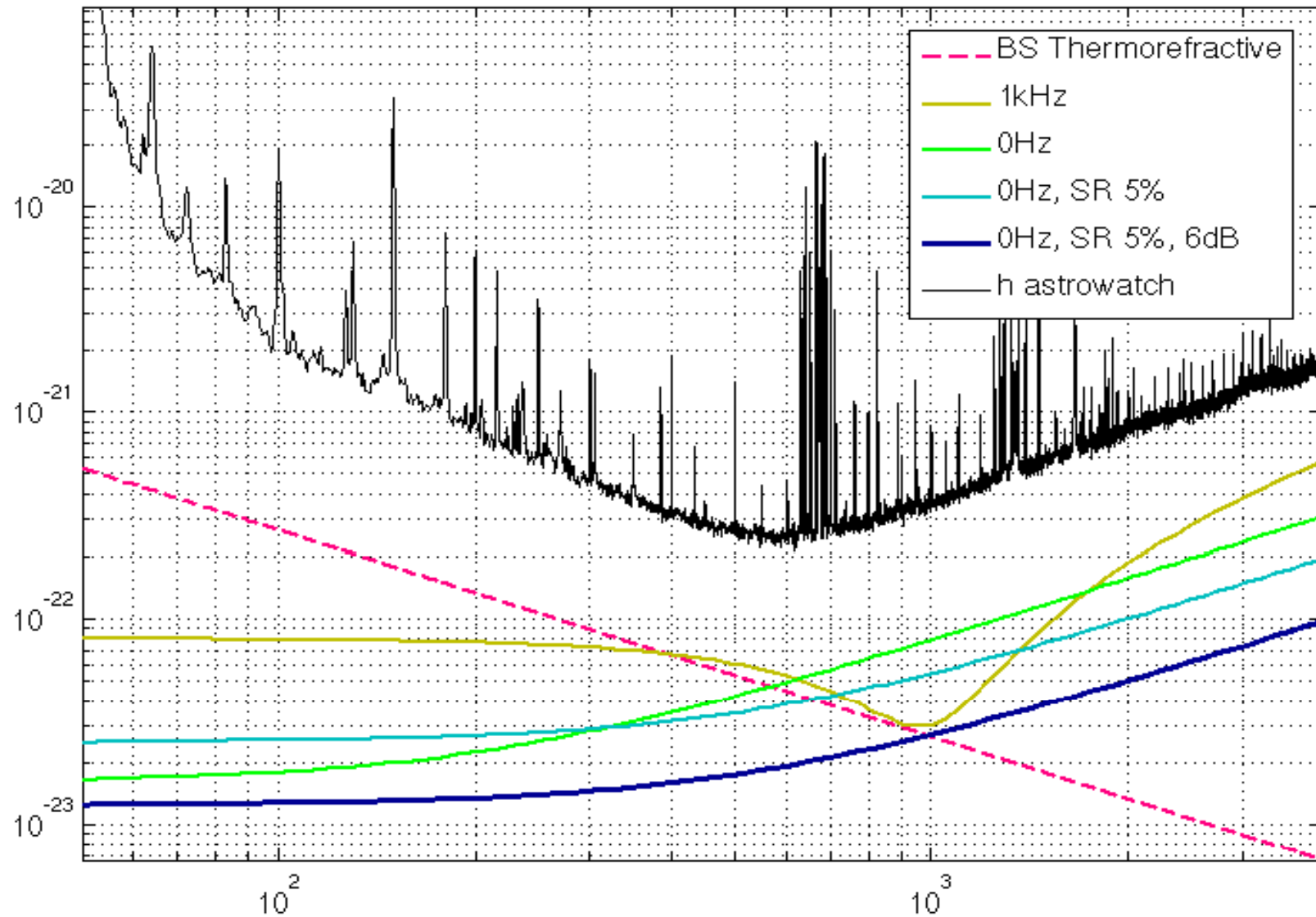

# Quantum Noise GEO600 vs. GEO-HF

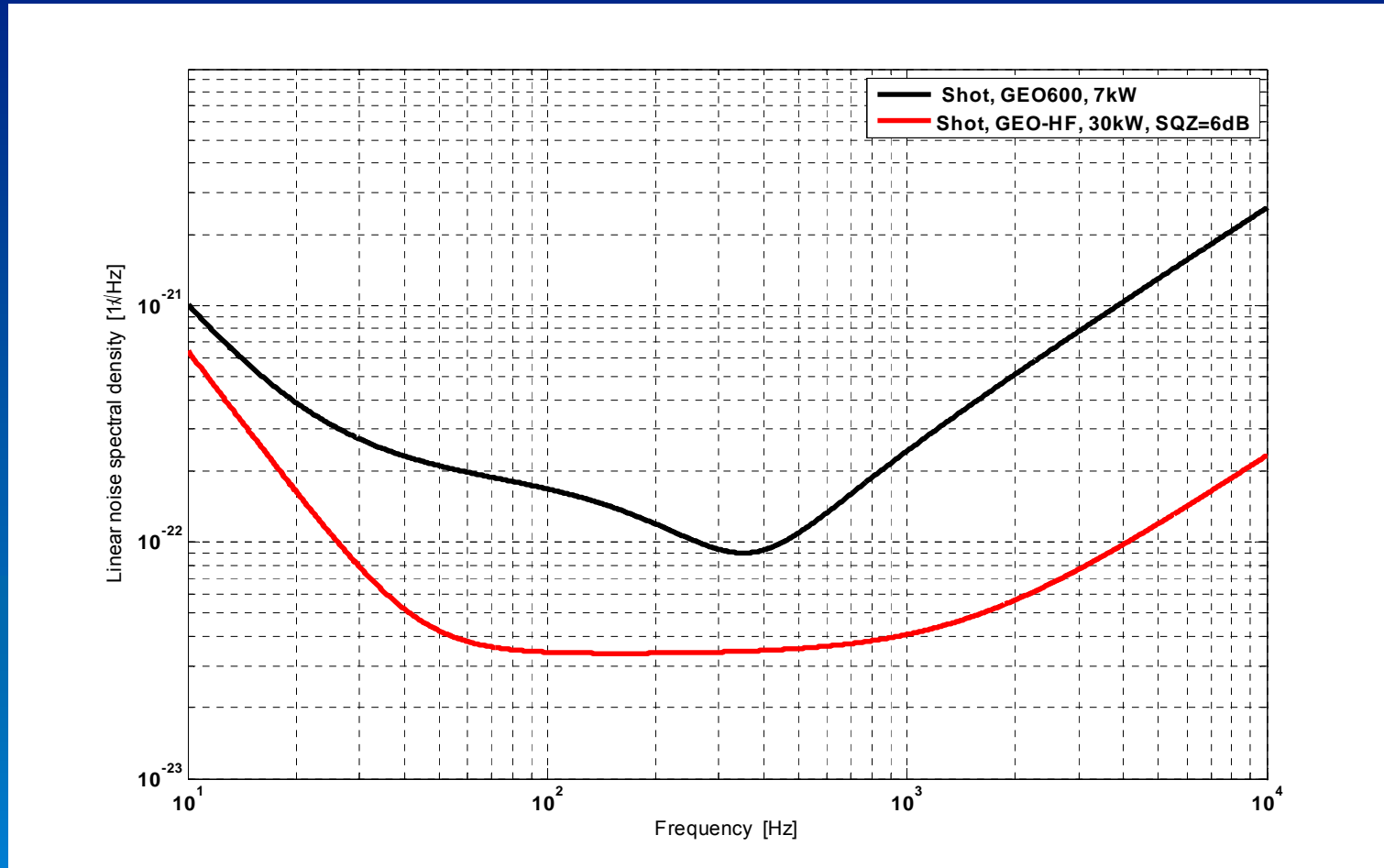

GEO600: 7kW, Schnupp Modulation, 550Hz detuning  
GEO-HF: 30kW, DC Readout, OMC, Tuned, broadband

# GEO HF Noises

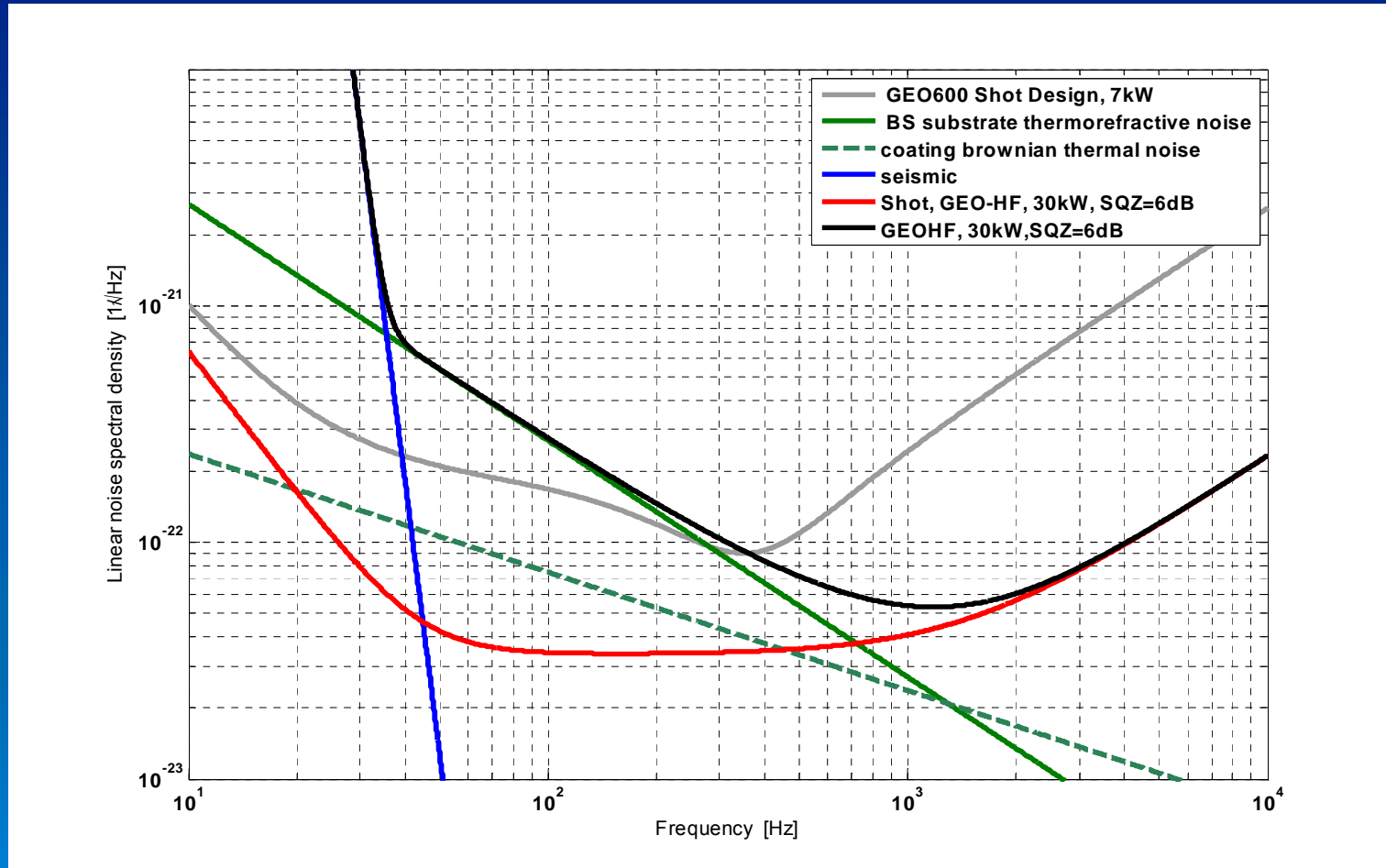



# Timeline / Summary



Spring 2009

- DC readout
- OMC
- In vacuum read out
- Squeezed light into output port

> Fall 2009

- Increase laser power
- Exchange main mirrors



# Additional vacuum tank TCOc



- $75^3 \text{ cm}^3$
- Viton gaskets ( $10^{-6}$  mbar)
- Viewport between TCOb and TCOc  
(Will it be a problem?)  
So far we do not see any  
Isolated platform inside

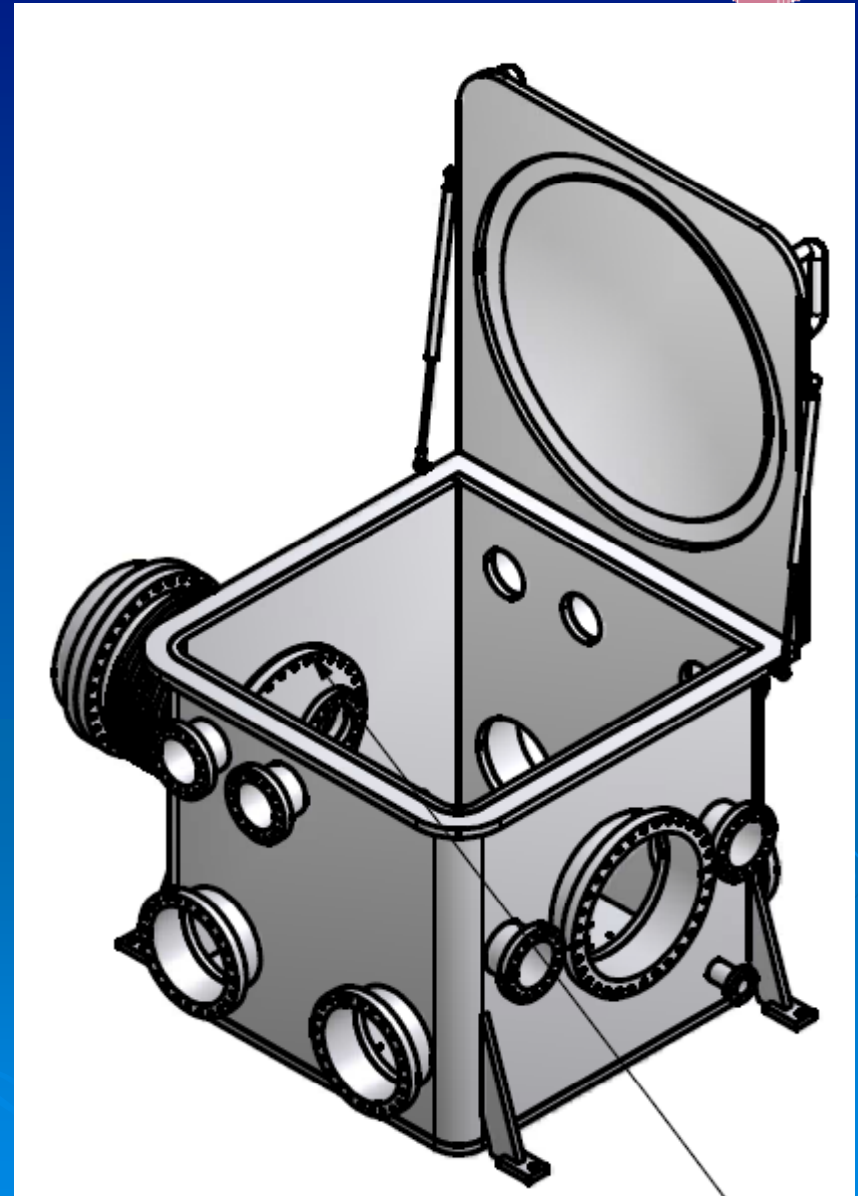

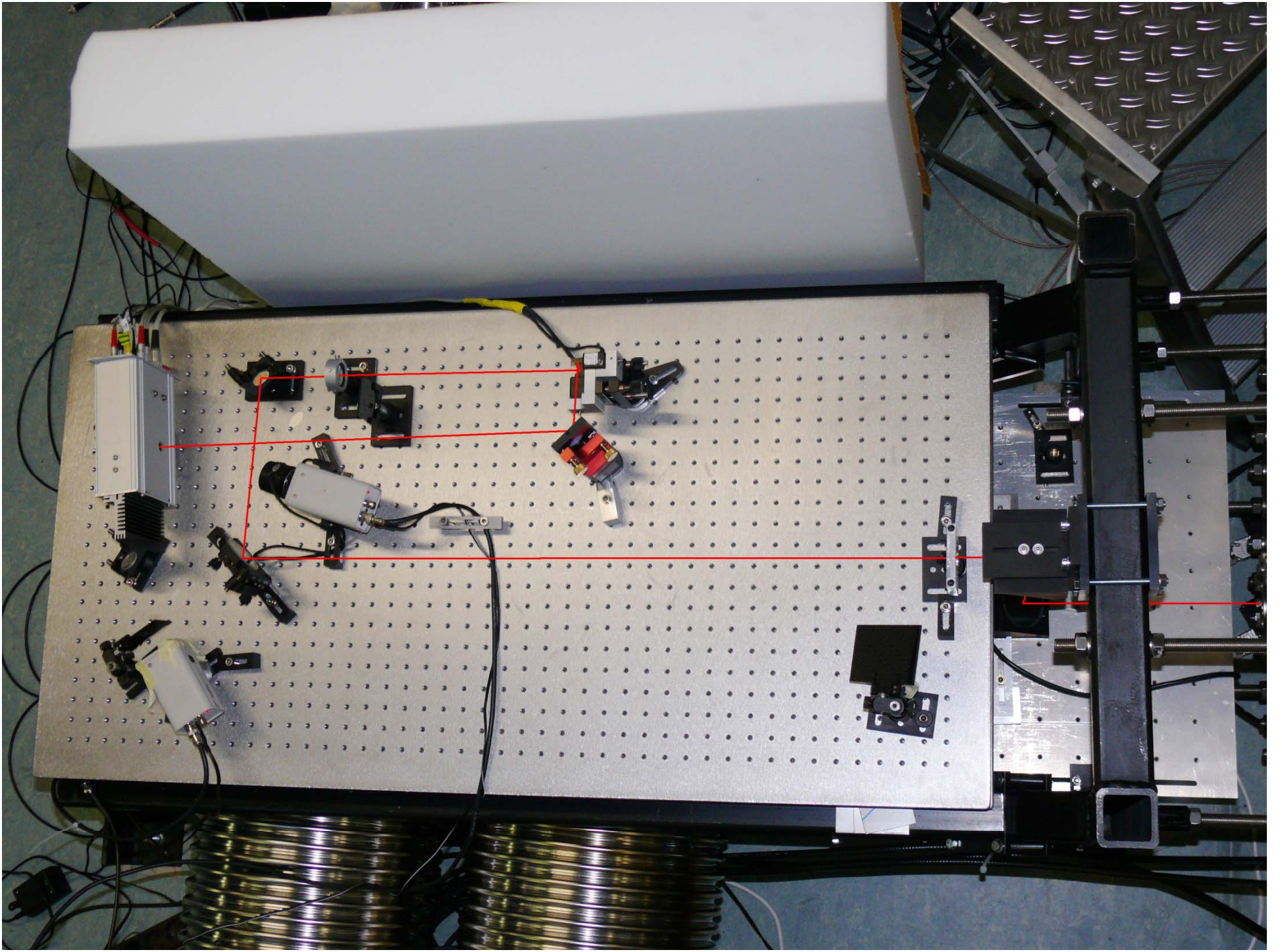

$$\eta_{\text{sqz}} = \eta_{\text{intra}} \eta_{\text{esc}} \eta_{\text{lin}} \eta_{\text{homo}} \eta_{\text{det}}$$

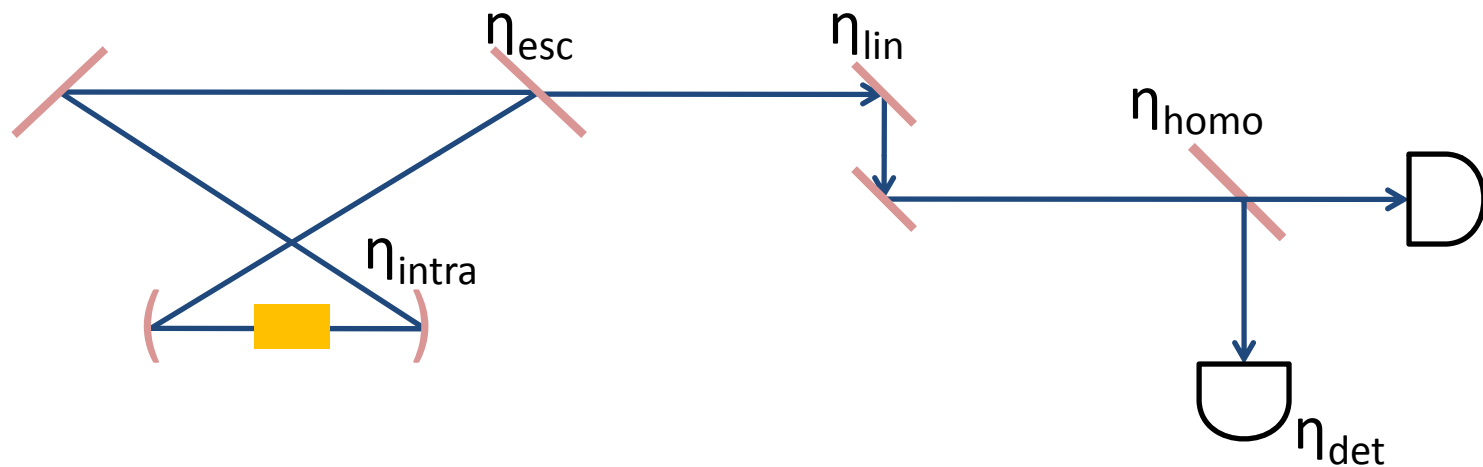

$\eta_{\text{intra}}$  – Intra-cavity Efficiency  
 $\eta_{\text{esc}}$  – Escape Efficiency  
 $\eta_{\text{lin}}$  – Transmission Efficiency  
 $\eta_{\text{homo}}$  – Homodyne Efficiency  
 $\eta_{\text{det}}$  – Detector Efficiency

→ Intra-cavity nonlinear process  
 → Ratio between output coupling rate to total cavity decay rate  
 → From Cavity to Detection  
 → Square of the Fringe Visibility  
 → Photodetector Efficiency



## Hemilithic vs Bow-tie Configuration



### Hemilithic (Standing Wave)

- Fewer reflecting surfaces, thus having lower loss
- Negligible spatial and polarisation distortion through its normal incidence operation.
- Limited number of input ports/ reflected beams from normal incidence operation.
- Single air/crystal interface, but greater difficulty in exchange of crystals
- Squeezer in hemilithic configuration to be installed at GEO600.

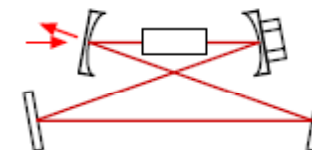

### Bow-tie (Travelling Wave)

- Inherent isolation to backscattered light
  - Less critical on additional Faraday isolation
- Bowtie configuration minimizes astigmatism.
- Ready access to multiple input ports/ reflected beams, due to their physical separation.
- Ability for easy exchange of crystals.
- The travelling wave characteristic makes the phase matching condition less dependent on temperature.





# OPO Design

## Doubly Resonant Cavity

Cavity resonant at both fundamental (1064nm) and pump (532nm) wavelengths.

### Advantages

- Simplicity of obtaining a cavity length error signal (using the pump 532nm field)
- Assurance of optimum mode matching of the interacting fields.
- Non-matched spatial components of the pump field (to the cavity mode) filtered
- The pump field amplitude is resonantly enhanced, giving a higher nonlinear gain for the same input pump power.
  - Allows possibility of increasing the transmission of the output coupler at 1064nm to increase  $\eta_{\text{esc}}$ .
- Less critical to internal cavity losses.
- Provide additional signal for phase-matching locking (if required).



# OPO Design

## Nonlinear Crystal



Choice between 2 crystals: PPKTP and MgO:LiNbO<sub>3</sub>

### PPKTP

- Very high nonlinearity via the use of the  $d_{33}$  of KTP.
- Grey tracking was a known problem when PPKTP is used near the UV wavelength (795/397 nm). To date, we have no data on grey tracking at 1064/532 nm.
- Best result obtained was > 9 dB squeezing (Tokyo University).

### MgO:LiNbO<sub>3</sub>

- Lower nonlinearity compare with PPKTP
- More robust than PPKTP.
- MgO doping is used to increase the photo-refractive damage threshold.
- Larger parasitic photothermal effects.
- Squeezer using MgO:LiNbO<sub>3</sub> to be installed at GEO600.
- Best results obtained was > 10 dB of squeezing (AEI Hannover).

- **Configuration:** Doubly Resonant Bow-Tie Cavity
- **Crystal:** PPKTP [Flat-wedge geometry]
- **Finesses**  $\sim \mathcal{F} = 50$  for 1064nm,  $\sim \mathcal{F} = 100$  for 532nm
- **Temperature Control:** Oven and Newport Temperature Controller
- **Optical Path Length:**  $\sim 700$ mm
- **Physical Dimensions:**  $\sim 200$  mm x 150mm

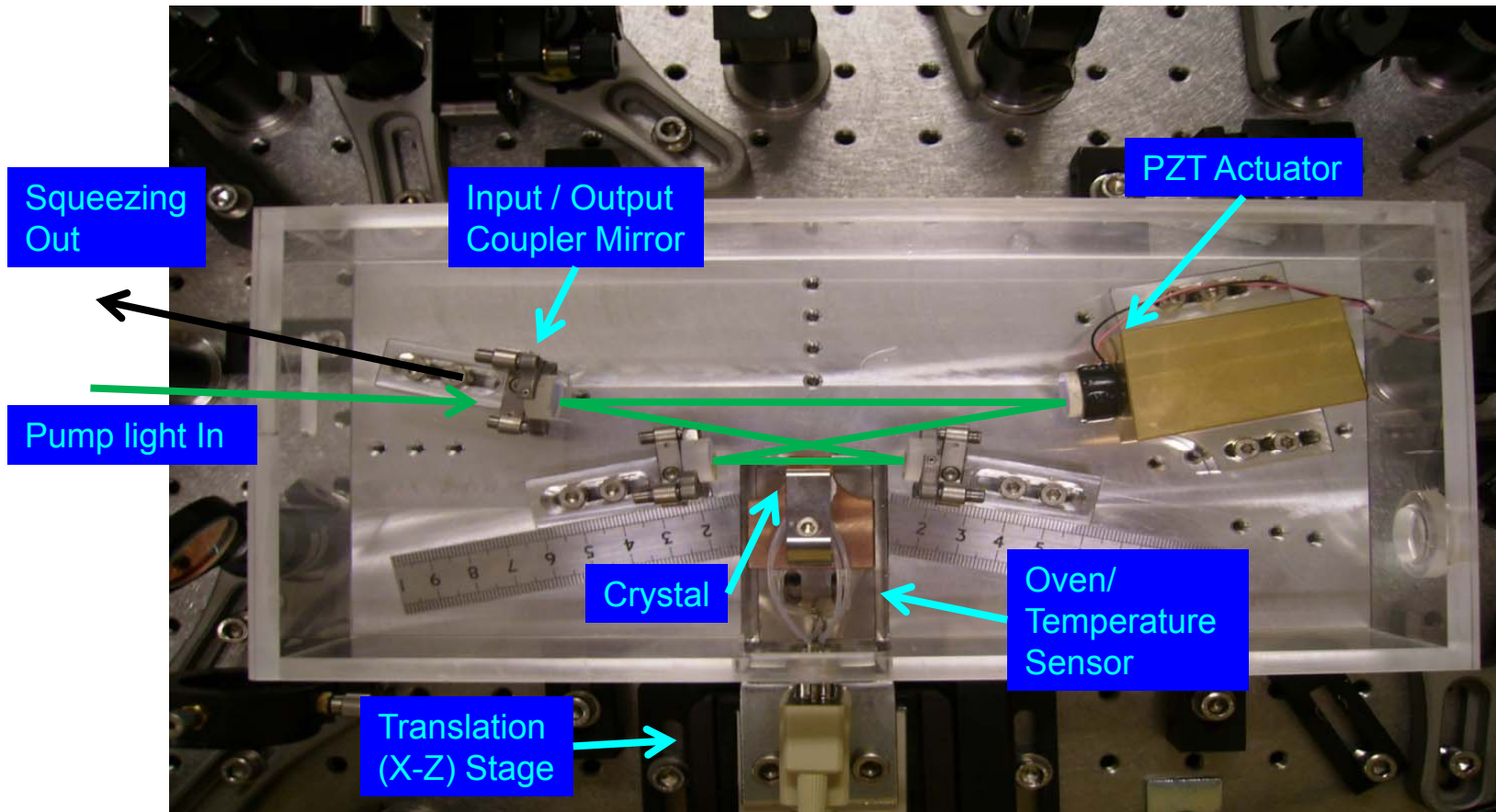

## **Dispersion Compensation**

- The reflections at mirrors from dielectric coatings will produce a differential phase shift between the pump and fundamental fields. Dispersion compensation is required to co-resonate both fields, obtained through the use of a flat- (1-2 degree) wedge surface geometry of the nonlinear crystal.

## **Cavity Length Control**

- Pound-Drever-Hall locking with cavity error signal derived from the reflected pump (532nm) field.
- Control of cavity length is done via a single PZT with a locking bandwidth of 20 kHz. If needed, a high speed PZT coupled with Molybdenum rod can extend the locking bandwidth to around 200 kHz.

## **Squeezed Quadrature and Local Oscillator (LO) phase control**

- Coherent (Frequent Shifted Sideband or F.S.S.) locking to implemented.

## **Temperature**

- A Newport temperature controller (Series 3040) can be used to control the crystal phase matching temperature accurate to  $\pm 1$  mK (long term stability).

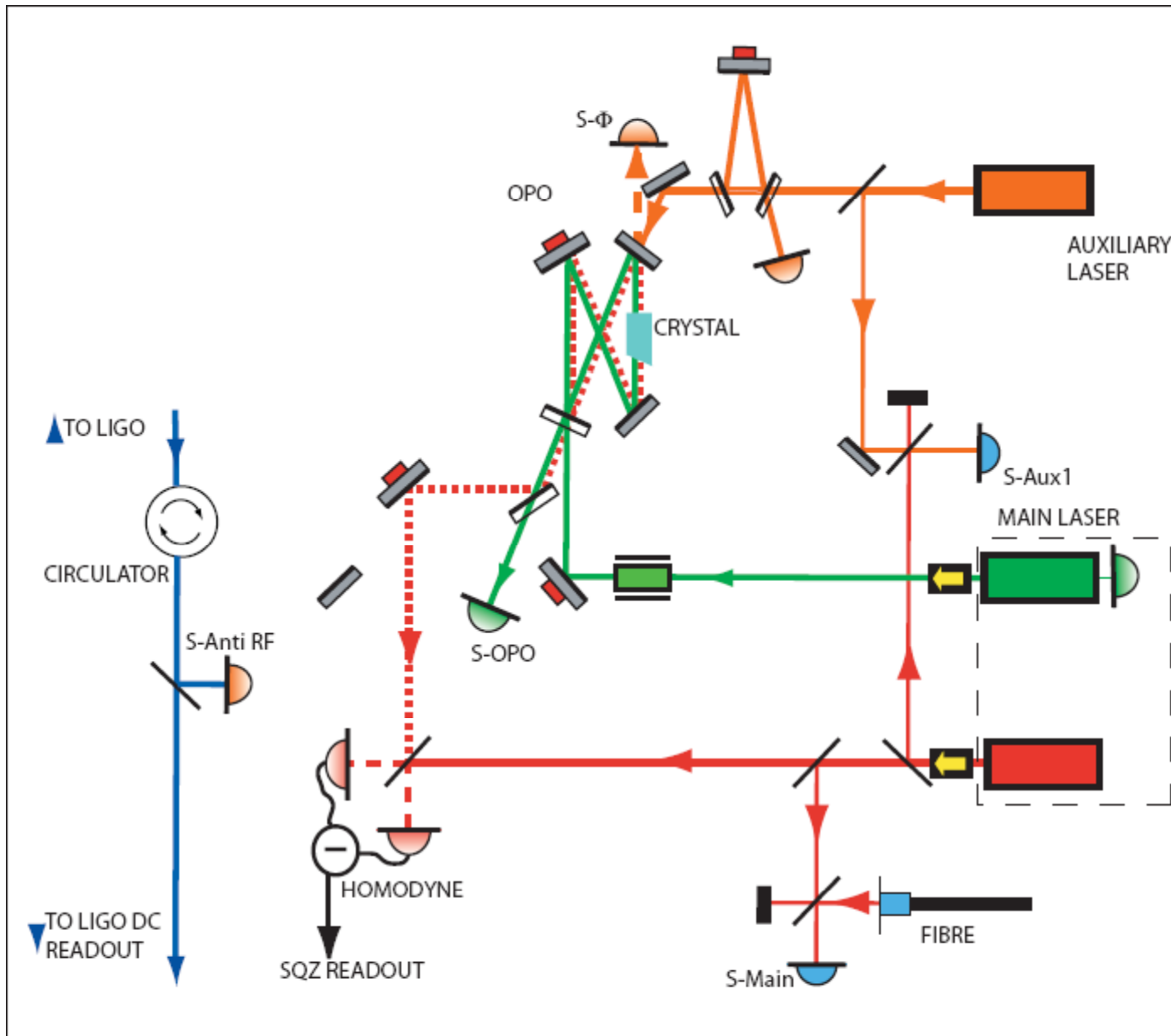

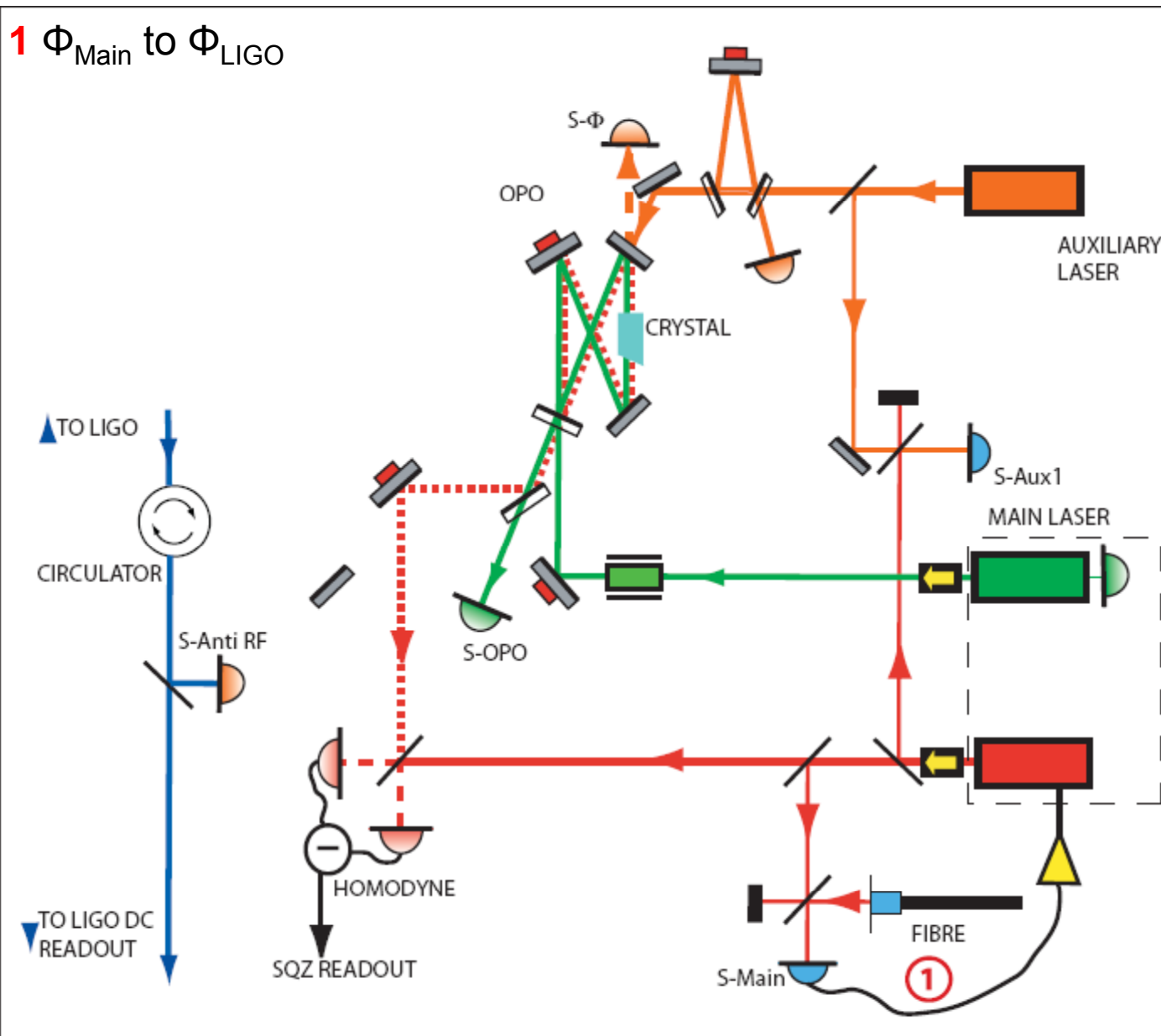

- 1  $\Phi_{\text{Main}}$  to  $\Phi_{\text{LIGO}}$
- 2  $\Phi_{\text{Aux}}$  to  $\Phi_{\text{Main}}$

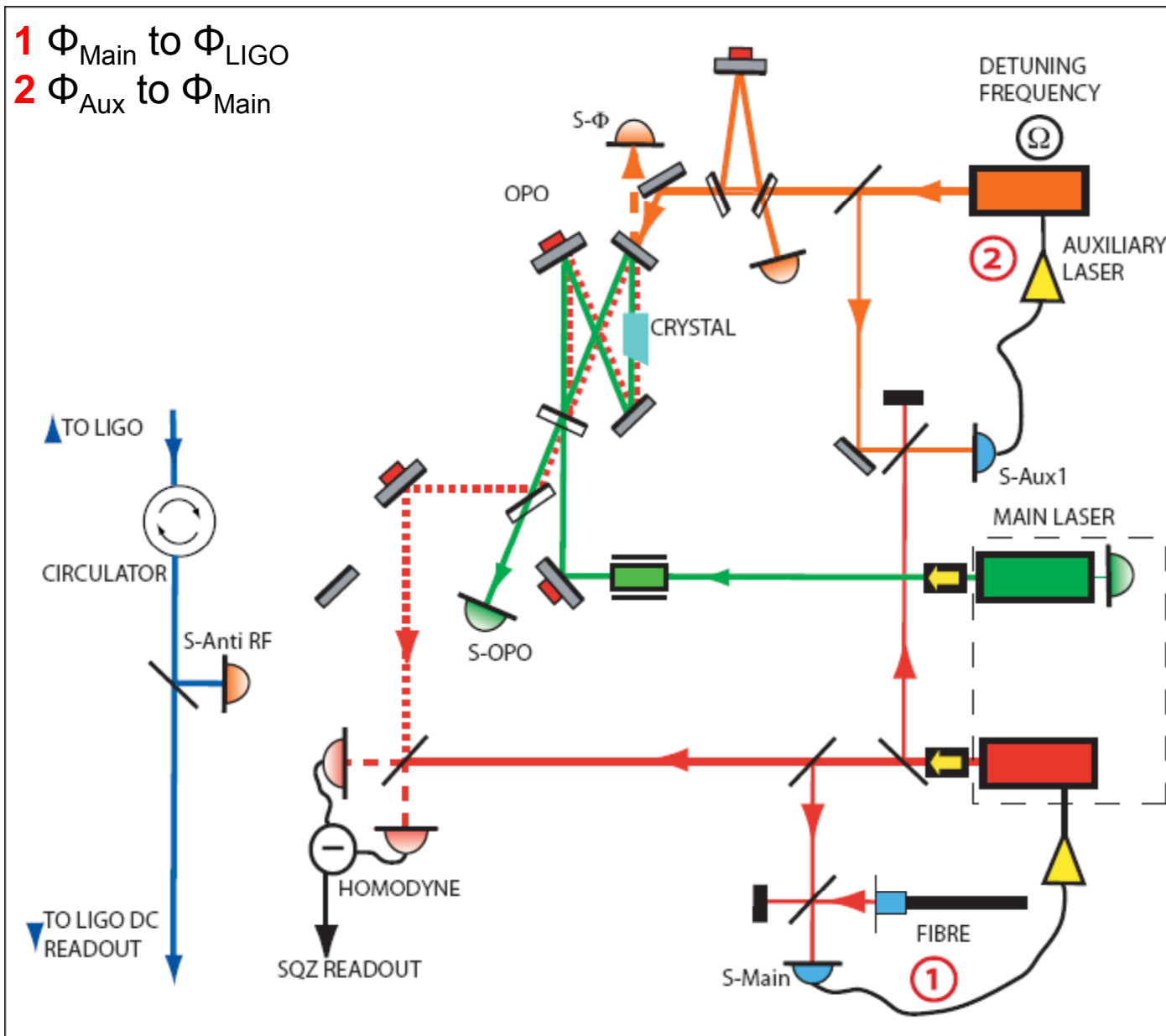

- 1  $\Phi_{\text{Main}}$  to  $\Phi_{\text{LIGO}}$
- 2  $\Phi_{\text{Aux}}$  to  $\Phi_{\text{Main}}$
- 3 SHG Lock at  $\omega_{\text{Main}}$

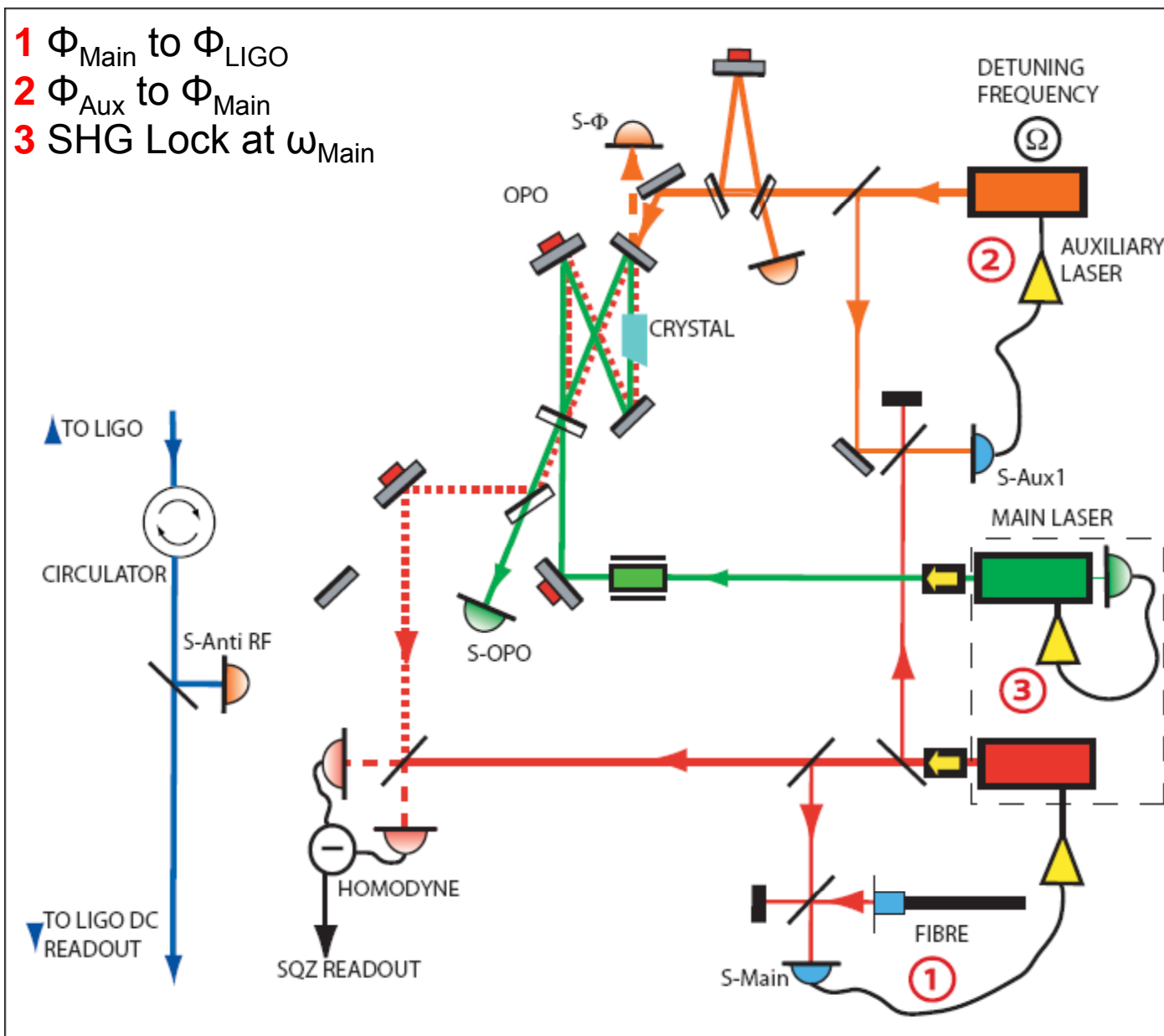



- 1  $\Phi_{\text{Main}}$  to  $\Phi_{\text{LIGO}}$
- 2  $\Phi_{\text{Aux}}$  to  $\Phi_{\text{Main}}$
- 3 SHG Lock at  $\omega_{\text{Main}}$
- 4 MC Lock at  $\omega_{\text{Aux}}$

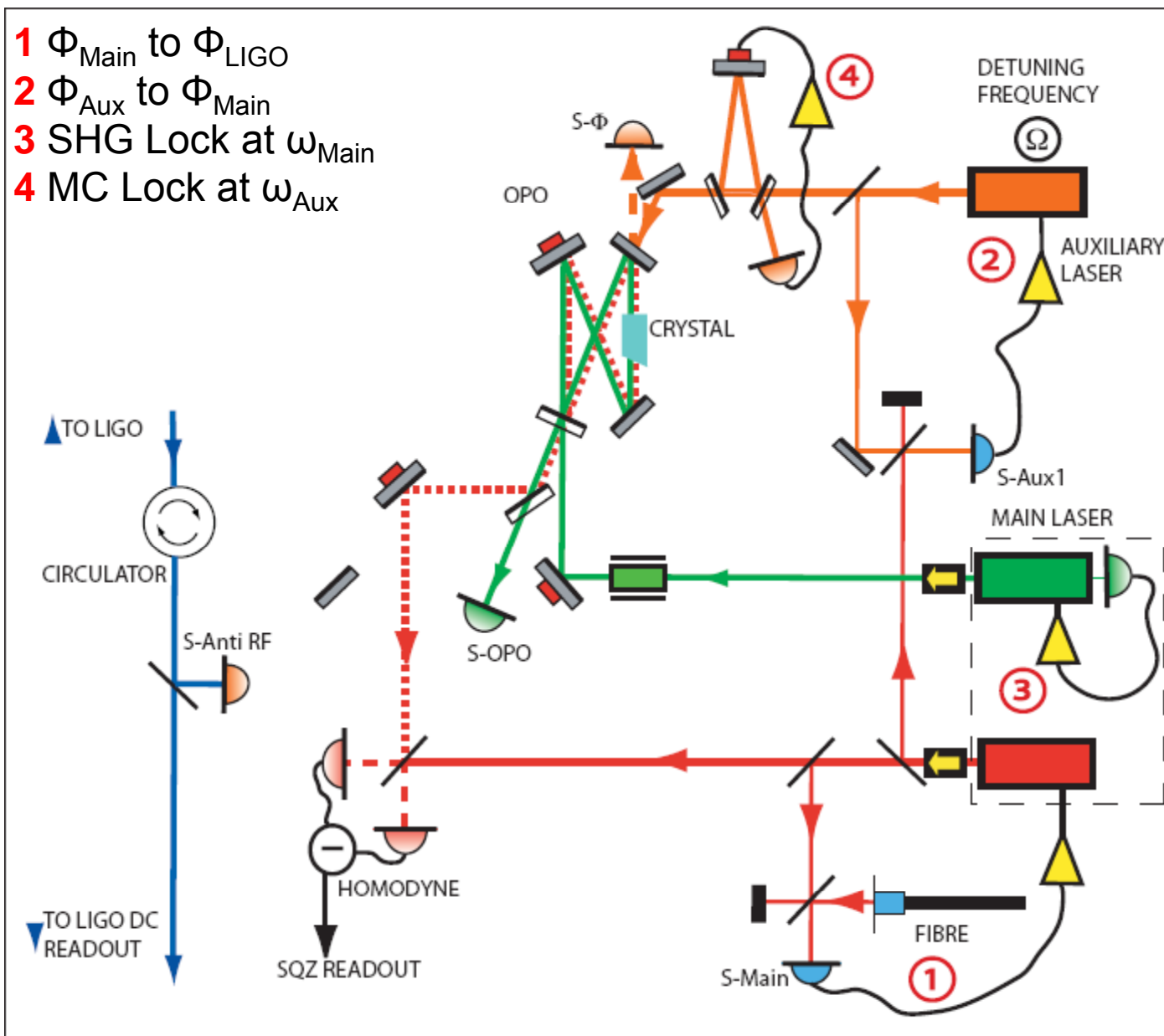

- 1  $\Phi_{\text{Main}}$  to  $\Phi_{\text{LIGO}}$
- 2  $\Phi_{\text{Aux}}$  to  $\Phi_{\text{Main}}$
- 3 SHG Lock at  $\omega_{\text{Main}}$
- 4 MC Lock at  $\omega_{\text{Aux}}$
- 5 OPO Cavity at  $\omega_{\text{Pump}}$

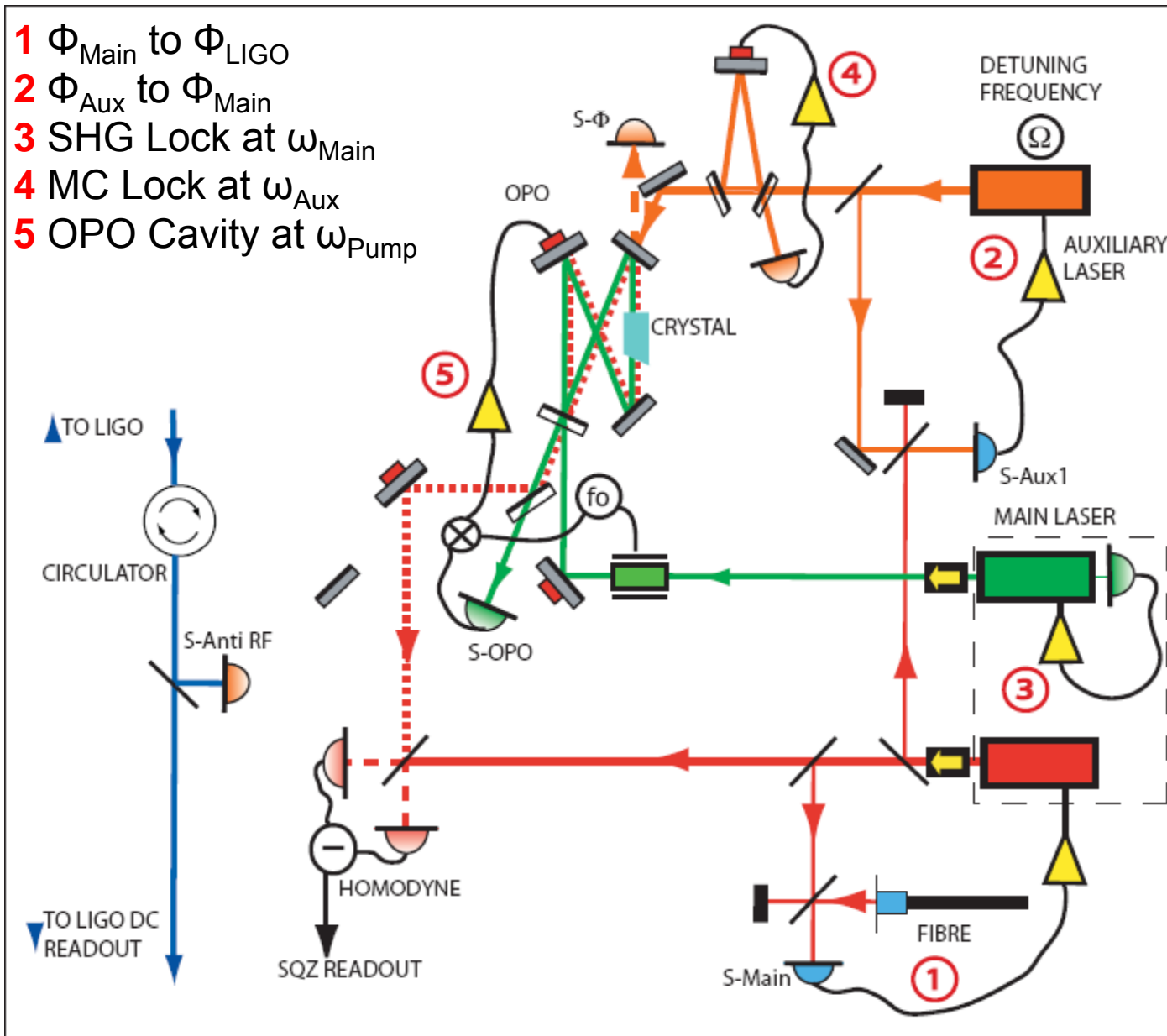

- 1  $\Phi_{\text{Main}}$  to  $\Phi_{\text{LIGO}}$
- 2  $\Phi_{\text{Aux}}$  to  $\Phi_{\text{Main}}$
- 3 SHG Lock at  $\omega_{\text{Main}}$
- 4 MC Lock at  $\omega_{\text{Aux}}$
- 5 OPO Cavity at  $\omega_{\text{Pump}}$
- 6  $\Phi_{\text{Pump}}$  to  $\Phi_{\text{F.S.S.}}$

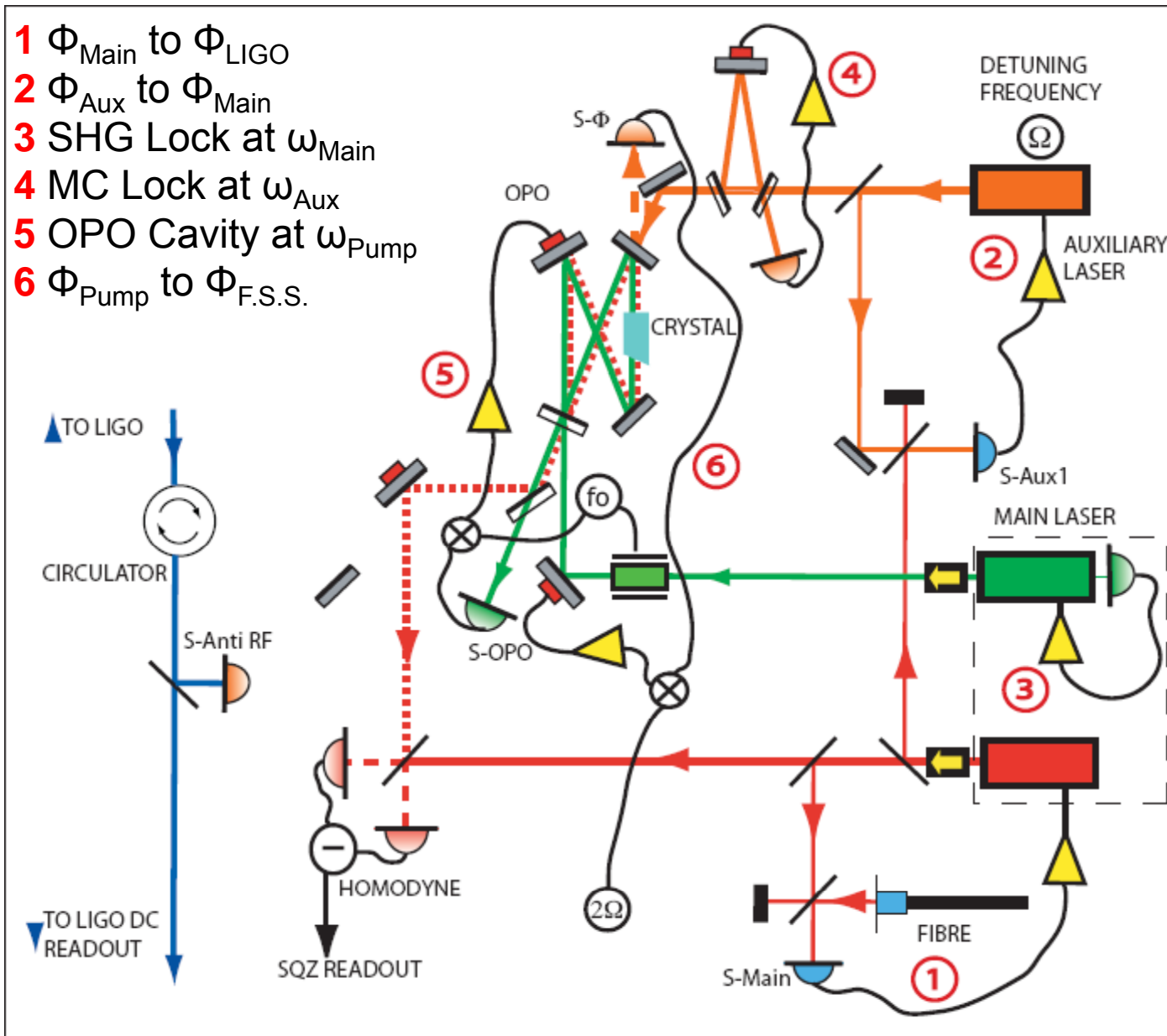

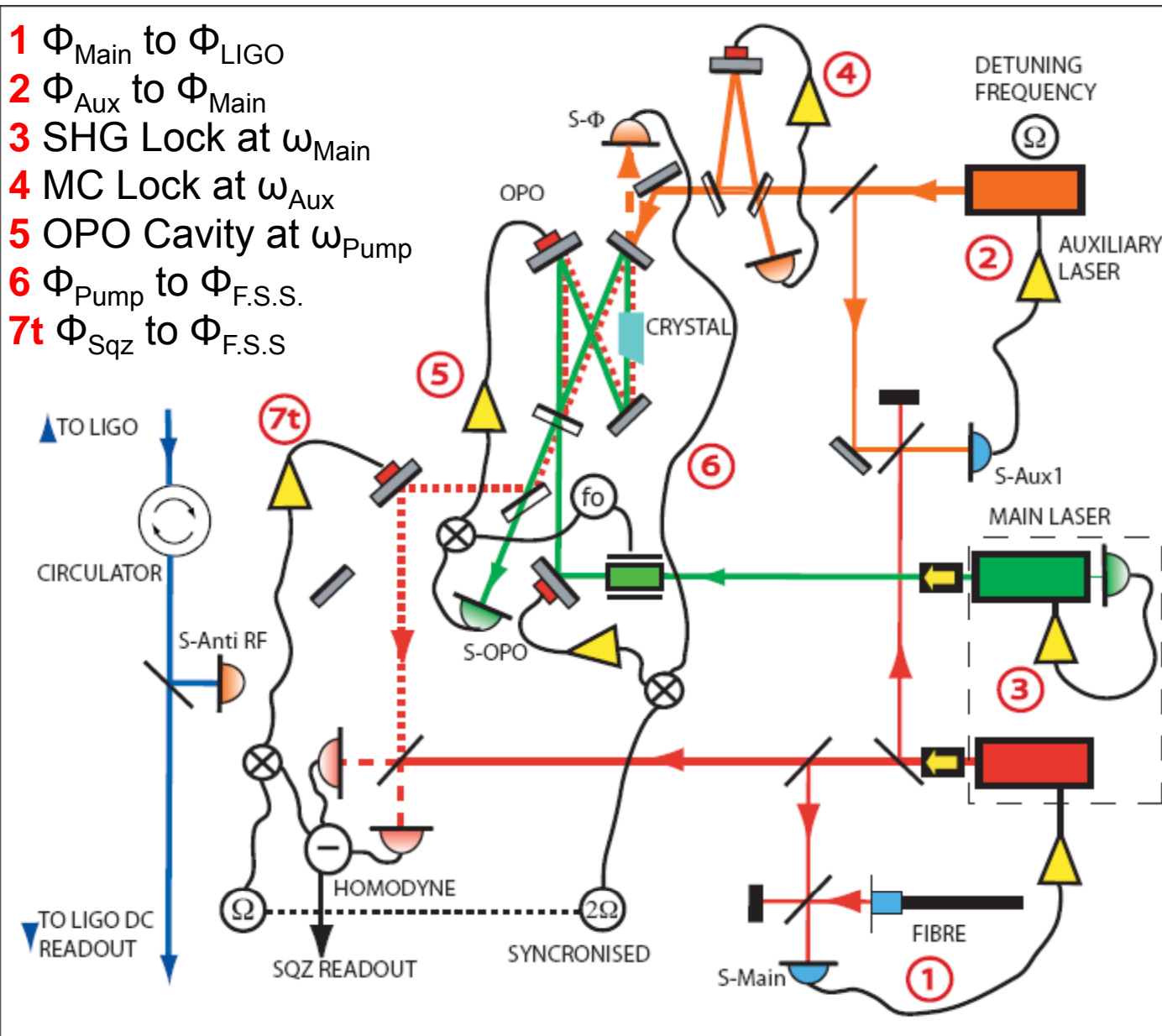

- 1  $\Phi_{\text{Main}}$  to  $\Phi_{\text{LIGO}}$
- 2  $\Phi_{\text{Aux}}$  to  $\Phi_{\text{Main}}$
- 3 SHG Lock at  $\omega_{\text{Main}}$
- 4 MC Lock at  $\omega_{\text{Aux}}$
- 5 OPO Cavity at  $\omega_{\text{Pump}}$
- 6  $\Phi_{\text{Pump}}$  to  $\Phi_{\text{F.S.S}}$

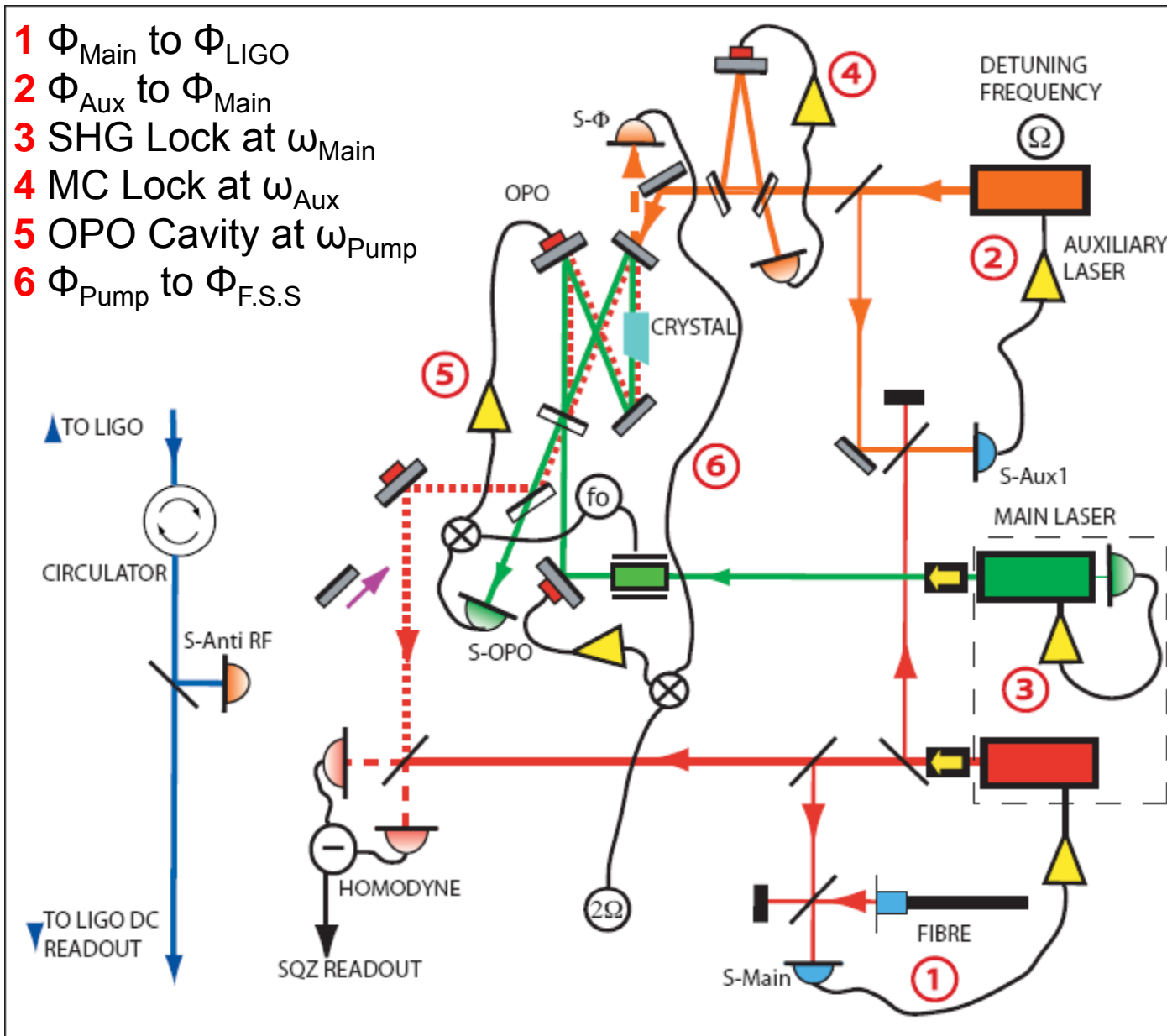

- 1  $\Phi_{\text{Main}}$  to  $\Phi_{\text{LIGO}}$
- 2  $\Phi_{\text{Aux}}$  to  $\Phi_{\text{Main}}$
- 3 SHG Lock at  $\omega_{\text{Main}}$
- 4 MC Lock at  $\omega_{\text{Aux}}$
- 5 OPO Cavity at  $\omega_{\text{Pump}}$
- 6  $\Phi_{\text{Pump}}$  to  $\Phi_{\text{F.S.S}}$

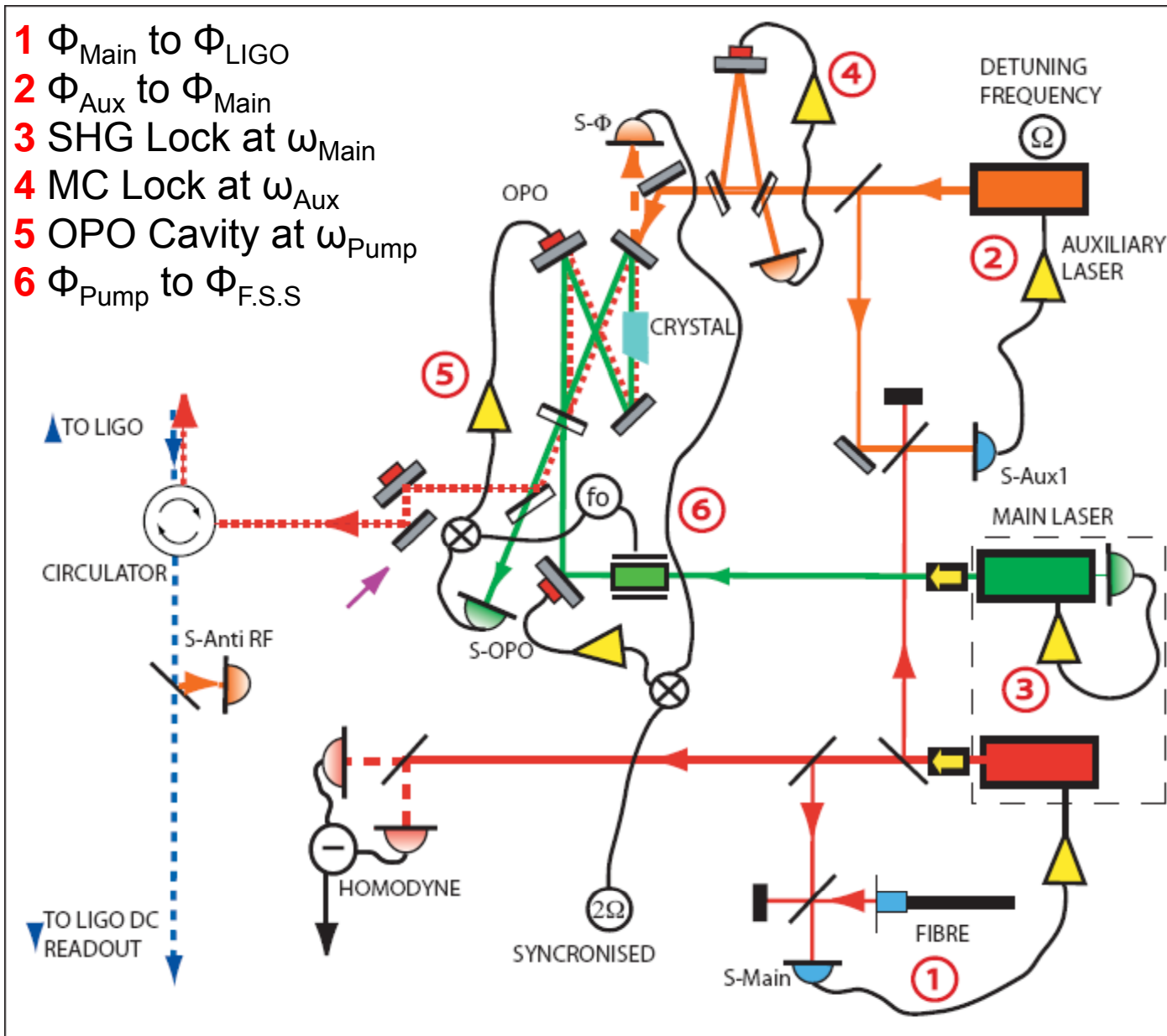

- 1  $\Phi_{\text{Main}}$  to  $\Phi_{\text{LIGO}}$
- 2  $\Phi_{\text{Aux}}$  to  $\Phi_{\text{Main}}$
- 3 SHG Lock at  $\omega_{\text{Main}}$
- 4 MC Lock at  $\omega_{\text{Aux}}$
- 5 OPO Cavity at  $\omega_{\text{Pump}}$
- 6  $\Phi_{\text{Pump}}$  to  $\Phi_{\text{F.S.S.}}$
- 7L  $\Phi_{\text{LIGO LO}}$  to  $\Phi_{\text{F.S.S.}}$

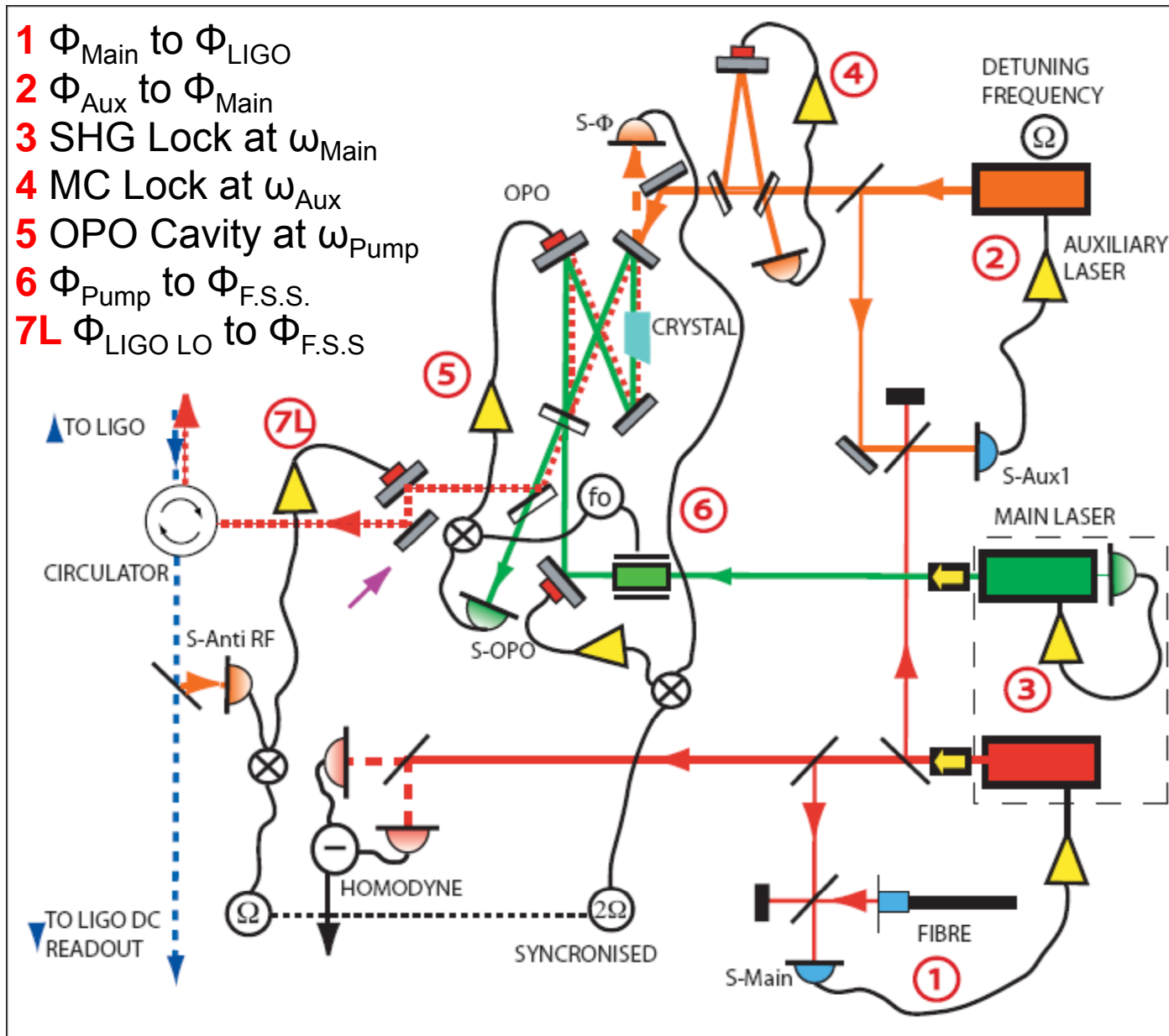

# H1 Squeezer Time Line



- ❑ Fixed start date for H1 experiment: 2/15/2011
  - ❑ Fixed end date for H1 experiment: 10/3/2011
- Better be ready!



# Plan

---

- ❑ Setting up the lasers (MIT/LHO)
  - Critical path: building the electronics
  - Grad student from MIT
  - Electronics support from LHO
- ❑ Building and commissioning the OPO (ANU)
  - Grad student from ANU
  - Electronics support from LHO
- ❑ Characterization of the squeezer (ANU/LHO)
- ❑ Homodyne detector (AEI)
- ❑ Experiment at H1

# Person power

Item	Task	Time
Grad student (MIT)	Laser setup	1 FTE/3 years
Grad student (ANU)	OPO setup	1 FTE/3 years
Grad student (AEI)	Homodyne detector	2 months
Scientist	Organizational	¼ FTE/3 years
LIGO scientist/EE	Electronics	½ FTE/2 years
Scientist/postdoc	H1 Experiment	8 months
Optical engineer	Faraday isolator	2 months
ANU scientist	OPO setup	A lot
Postdoc(?)	Support	½ FTE/3 years

# Budget

Task	Cost (k\$)
Optics	322
Electronics	121
Travel	59
ANU contribution	-13
AEI contribution	-3
Advanced LIGO contribution	-25
<b>Total without travel</b>	<b>418</b>
<b>Total with travel</b>	<b>477</b>
OPO technical risk	50

# Funding Profile (Rough Estimate)

---

## ❑ Equipment costs

- 88% first year
- 10% second year
- 2% last year

## ❑ Salary

- 33% for each year

## ❑ Travel

- 40% first years
- 40% second year
- 20% third year