



Direct Measurements of Spatial Homogeneity of Coating Mirror Thermal Noise for Interferometric Gravitational Wave Detectors

LIGO-G070622-00-R

Ilaria Taurasi

University of Sannio at Benevento, Italy
Caltech, September 8 2007

Supervisor: Dr. Eric D. Black

Purpose of my project

- Original purpose: to characterize experimentally the thermal noise of optimized mirror coatings
 - Due to fabrication problems, prototypes were not available on time
- Actual purpose: to verify the spatial homogeneity of mirror thermal noise at the Thermal Noise Interferometer (TNI)
 - Question: do measurements already taken at TNI reflect a general property of the entire coating, or are they position dependent?
 - To answer: measurements varying the vertical position of the laser beam incident point
 - Small spot (327.2×10^{-6} m diameter)

Thermal noise

- Thermal noise arises from the fluctuations of a macroscopic system which is at thermal equilibrium
- Two broad categories of thermal noise sources:
 - intrinsic (dissipative): driven by thermal forcing from internal fluctuations
 - Fluctuation – Dissipation Theorem (FDT)

FDT relates the spectrum of the thermal noise of a system to the mechanical dissipation therein

- extrinsic (non dissipative): arises when externally enforced temperature variations drive thermal fluctuations

$$S_x(\omega) = \frac{4k_B T \Re[Y(\omega)]}{\omega^2} \equiv \frac{4k_B T \sigma(\omega)}{\omega^2}$$

Mirror thermal noise: source of dissipation

- structural damping (internal friction): phase shift between stress and strain
 - ϕ is the figure of merit
- thermoelastic damping: inhomogeneous strain of an an elastic body that changes the temperature of the object
 - α coefficient of thermal expansion

Mirror thermal noise: the dissipation

- Coating thermoelastic noise: predicted by FDT when considering the thermoelastic damping as the loss mechanism

$$\Delta x^{(\alpha)} = \alpha_{eff} d_{tot} \Delta T$$

- Coating thermo-refractive noise: $\beta \neq 0$

$$\Delta x^{(\beta)} = \beta_{eff} \lambda_0 \Delta T$$

- Coating thermo-optic noise

$$S_{\text{coherent}}^{(\alpha+\beta)} = \left(\frac{\Delta x^{(\alpha)}}{\Delta T} + \frac{\Delta x^{(\beta)}}{\Delta T} \right)^2 S_{\Delta T}(f)$$

PSD of the fluctuations of the test mass

PSD of the temperature fluctuations

Mirror thermal noise: the dissipation (2)

- Brownian noise: associated with all forms of background dissipation. Predicted by FDT when considering the internal friction as the loss mechanism

- Losses within the beam spot (coating) contribute substantially to the thermal noise

$$S_x^{(B)}(f) = \frac{4k_B T d (1 + \sigma_c)(1 - 2\sigma_c)}{\pi^2 f E_c r_0^2} \phi$$

- Photothermal noise: arises from the test mass being heated, such absorption of photons from a laser beam with fluctuations

$$S_{\Delta T}(f) = S_{\Delta T}^{(T)}(f) + S_{\Delta T}^{(P)}(f)$$

↑ PSD of the temperature fluctuations ↑ Thermodynamical fluctuations ↑ Photothermal fluctuations

Coating thermal noise budget

- Total coating noise $S_{\Delta x}^{tot}(f) = S_{\Delta x}^{(B)}(f) + \left(\frac{\Delta x^{(\alpha)}}{\Delta T} + \frac{\Delta x^{(\beta)}}{\Delta T} \right)^2 S_{\Delta T}(f)$

AdvLIGO Noise Curve: $P_{in} = 125.0$ W

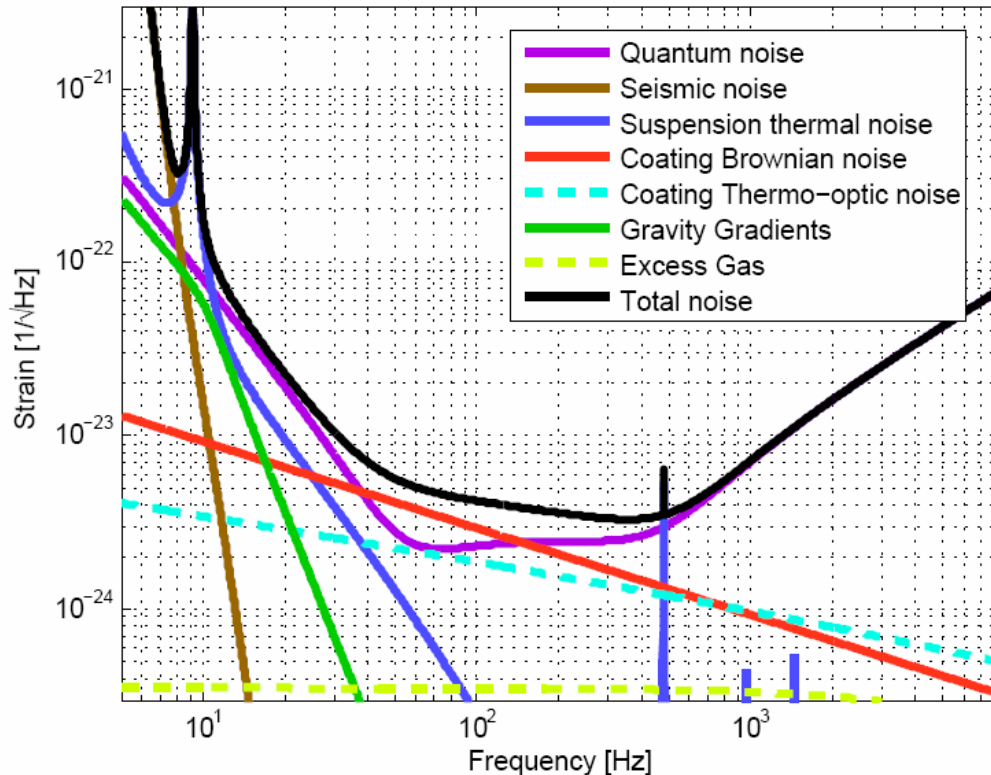

- Mirror thermal noise is expected to limit the IGWD in their most sensitive frequency bands noise levels
- LIGO's reach permits now to detect signals distant about 16 Mpc. We expect that by using doped tantalum coatings we'll be able to reduce this noise by 22%, thus will permit us to see spiraling binaries at a distance of 193 Mpc

Direct measurement of mirror thermal noise

- Suspended interferometers constructed to measure directly thermal noise

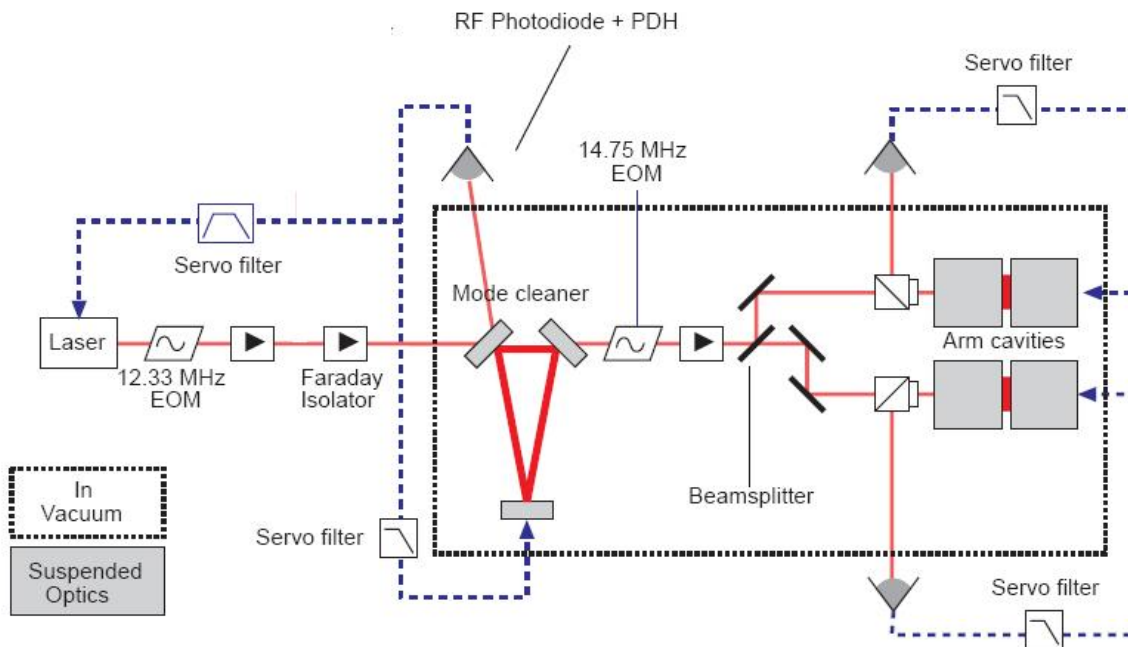

- 2 parallel Fabry-Perot cavities with identical lengths (12 mm) made from 4 identical and suspended mirrors

- Three suspended mirrors forming a mode cleaner that provides frequency stabilization and spatial filtering

- Arms are adjacent and parallel so that seismic vibrations affect them equally

- All test masses are in fused silica, the coating are quarter-wave stacks of $\text{SiO}_2/\text{Ta}_2\text{O}_5$

TNI - the layout

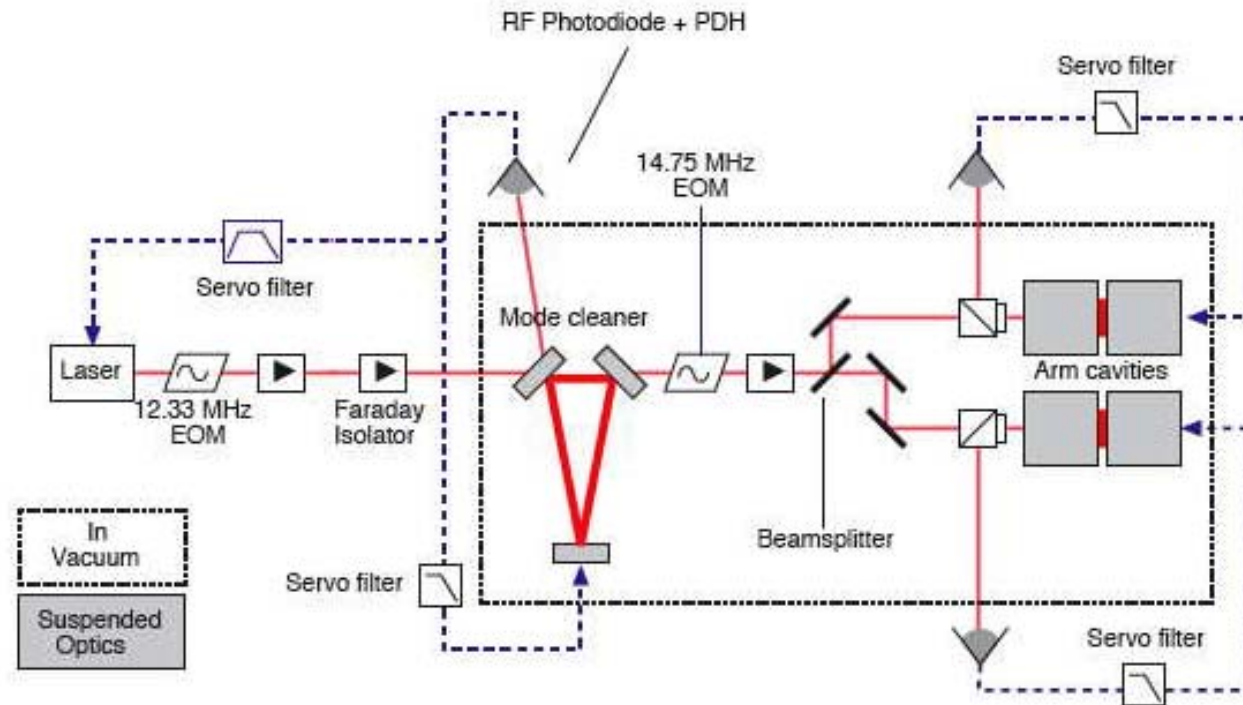

- Diode-pumped Nd: YAG
P=500 mW, $\lambda=1064$ nm
- Pockels Cell 12.33 MHz
- Mode cleaner (MC): the reflected beam goes back to a photodetector, the transmitted one reaches the two arm cavities
- Cavities: a BS separates the beam to the North Arm Cavity (NAC) and the South Arm Cavity (SAC). The reflected beam goes through different paths to two photodetectors

Two paths for the control system: at low frequencies the cavity is locked to the laser and at high frequencies the laser follows the cavity. A feedback servo system locks the mode cleaner and laser to each other

Pound-Drever-Hall (PDH) locking

- Difficulty in maintaining the FB cavity at resonance arising from laser instability and mirror displacement

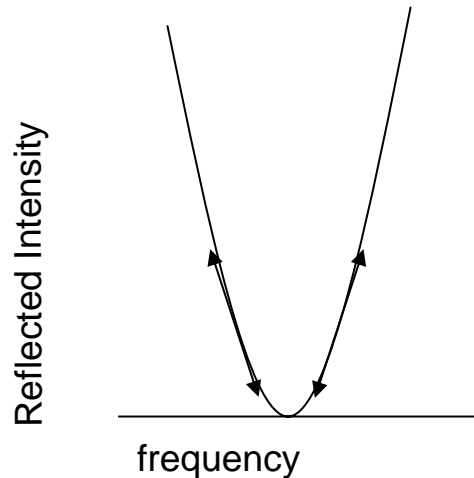

- By comparing the variation in the reflected intensity with the frequency variation we can tell which side of resonance we are on
- Once we have the measure of the derivative of the reflected intensity of the sidebands, we feed the measurement back to the laser and lock the cavity length to the laser wavelength

Pound-Drever-Hall (PDH) locking

- Difficulty in maintaining the FB cavity at resonance arising from laser instability and mirror displacement

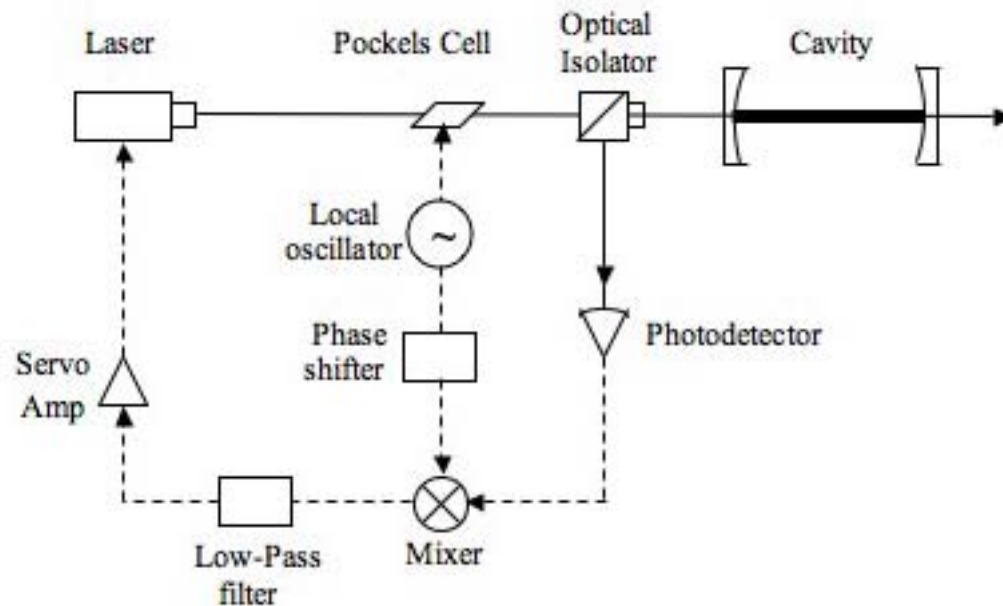

- The beam coming from the laser passes through a Pockels Cell that introduces the sidebands
- The output of the mixer is the *error signal*, proportional to the difference between the frequency beam going to the cavity and that of the reflected one

Mode cleaner (MC)

- MC provides, through a feedback, frequency stabilization for the laser and the spatial filtering

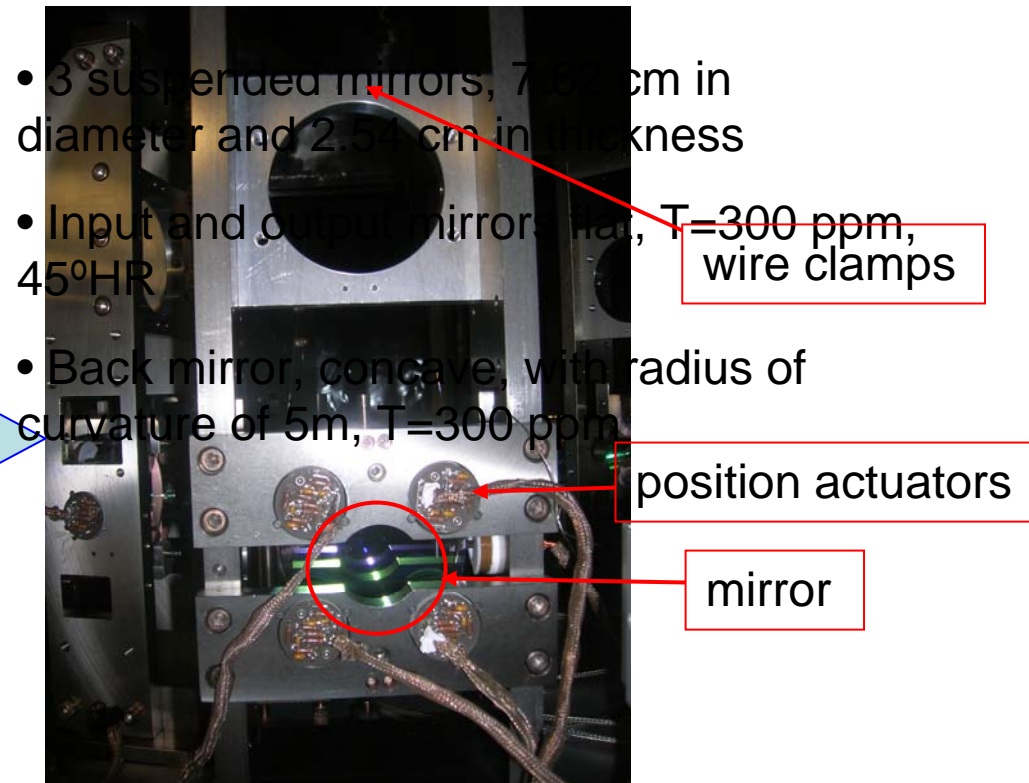
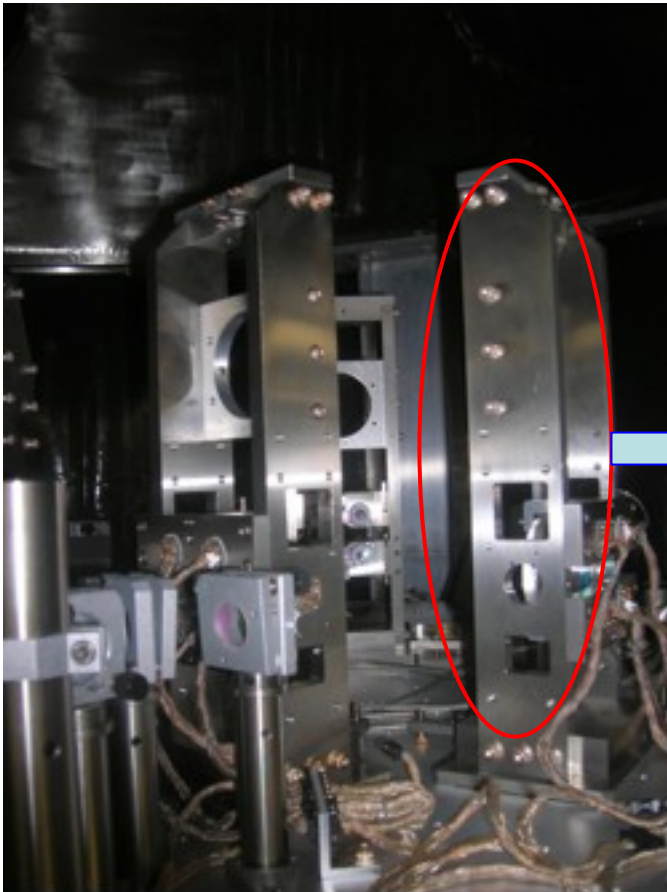

Arm cavities

- North Arm Cavity (NAC) and South Arm Cavity (SAC)

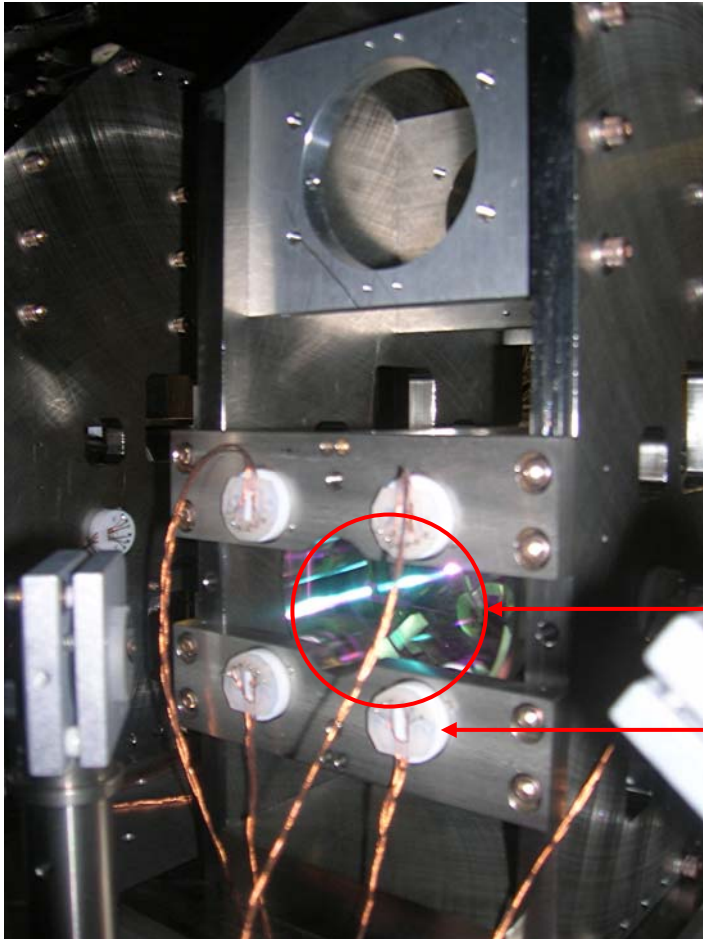

- Each mirror is 10.16 cm in diameter and thickness, radius of curvature is 1 m
- Design finesse of 10000
- Transmittivity $T=300$ ppm

mirror

magnets on the back surfaces for local damping

orientation alternates to minimize the mirrors' magnetic dipole moment

Tilting the mirrors

- To check whether the coating thermal noise was uniform at different points, we moved the beam spot by 3 mm vertically (about 10 times diameter of the spot)

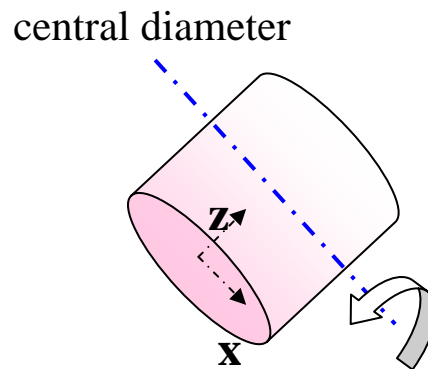
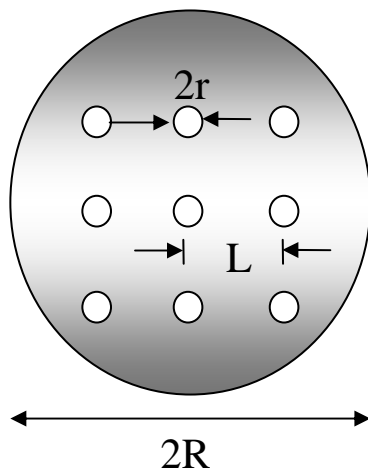

Moment of inertia of a cylinder around the pitch axis

$$I_{pitch} = \frac{1}{4} MR^2 + \frac{1}{12} Mh^2 = 2.7 \cdot 10^{-3} \text{ Kg} \cdot \text{m}^2$$

Pitch elastic constant

$$k_{pitch} = \omega_{pitch}^2 I_{pitch}$$

Torque to generate the tilt

$$\tau = k_{pitch} \theta; \theta = 3 \text{ millirad}$$

Torque as rotational force

$$\tau = mgd$$

Diameter of the spot beam 2r (cm)	Mirror surface radius R (cm)	Thickness of the mirror h (cm)	Density of silica (g/cm ³)	Radius of curvature Rc (cm)	Pitch frequency f (Hz)	Spot distance L (cm)
327.2*10 ⁻⁴	5.08	10.16	2.2	100	0.731	0.3

Tilting the mirrors (2)

We could offset the mass by

$$d = \frac{h}{2} - ch - r_w = 0.4 \text{ cm}$$

$$m = \frac{\tau}{gd} \approx 0.4 \text{ g}$$

- 2 stainless steel shims discs, each of 0.22 g, $r_w=0.63$ cm, added at the top of each other on the back edge of the SAC mirrors with acryano acrylane (superglue)

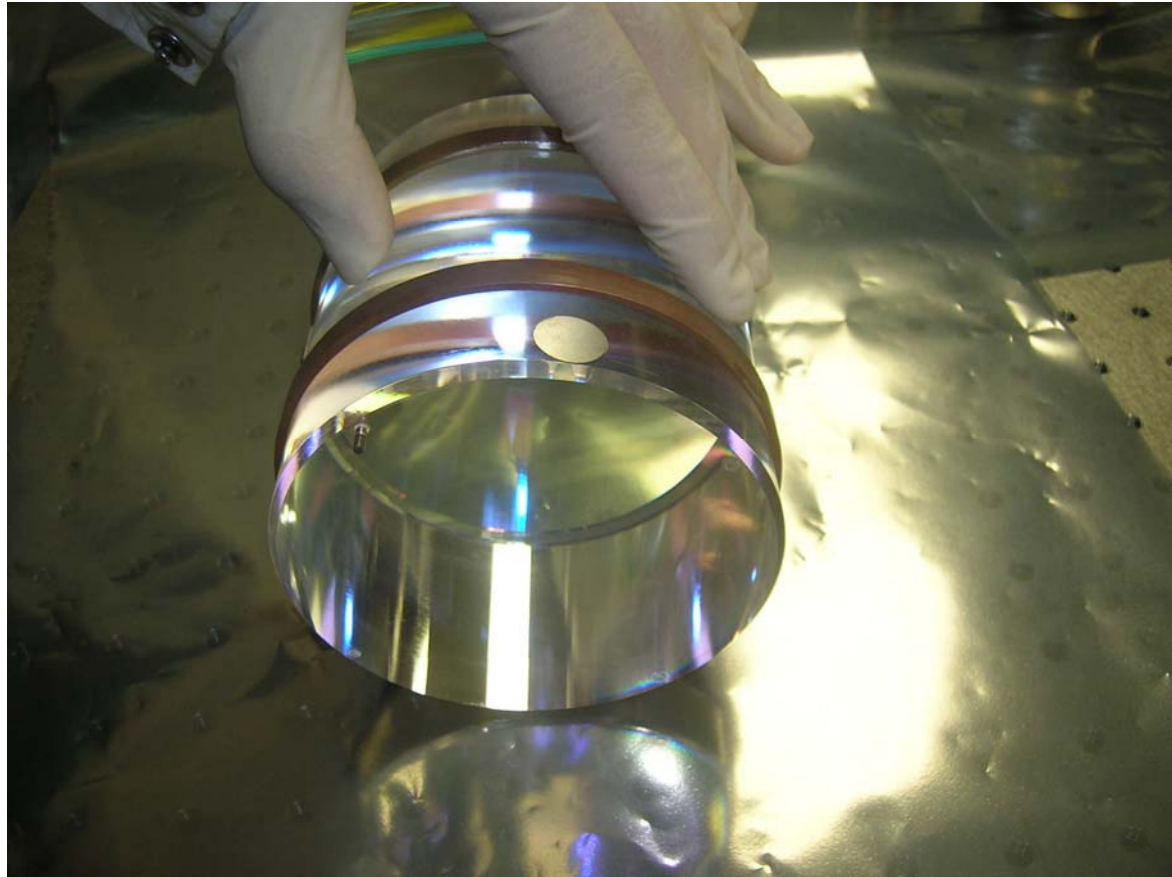

Alignment

- The natural cavity axis changed and moved the position of the beam by a distance of 3 mm

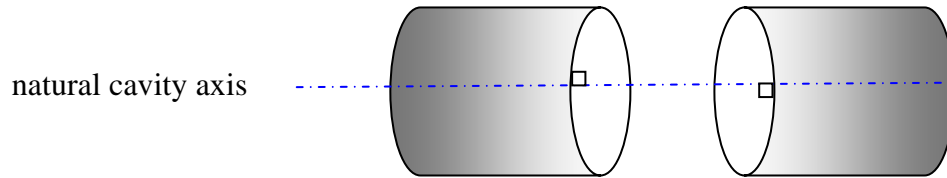

- difficulties in find the beam axis with tilted mirror and re-align the injection beam onto it

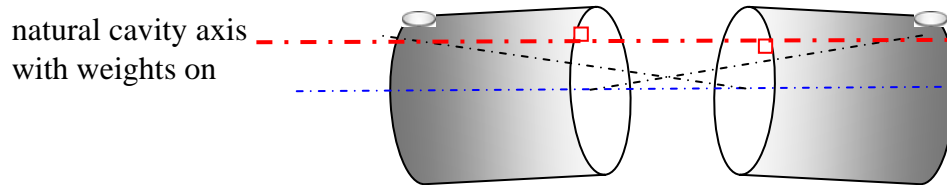

- multiple reflections

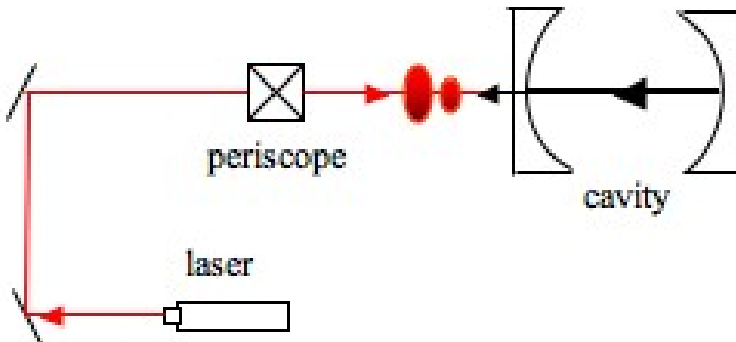

red pen laser coaxial with the output beam to align the reflected beams from the curved surfaces

two steering mirrors to adjust the beam going to the mirrors that comprises the periscope

Alignment

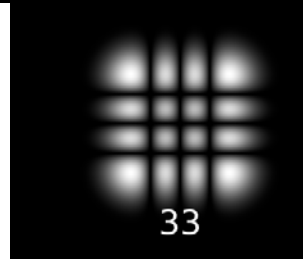
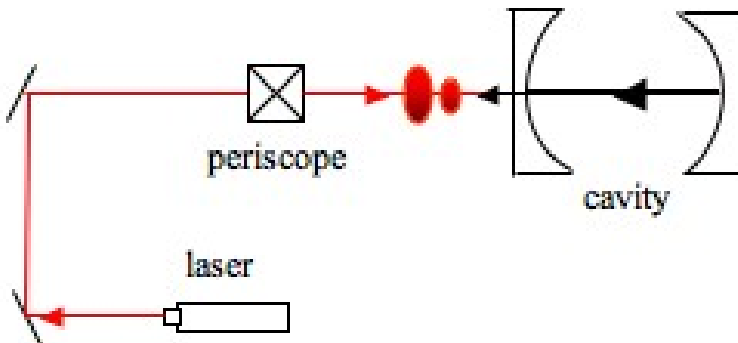
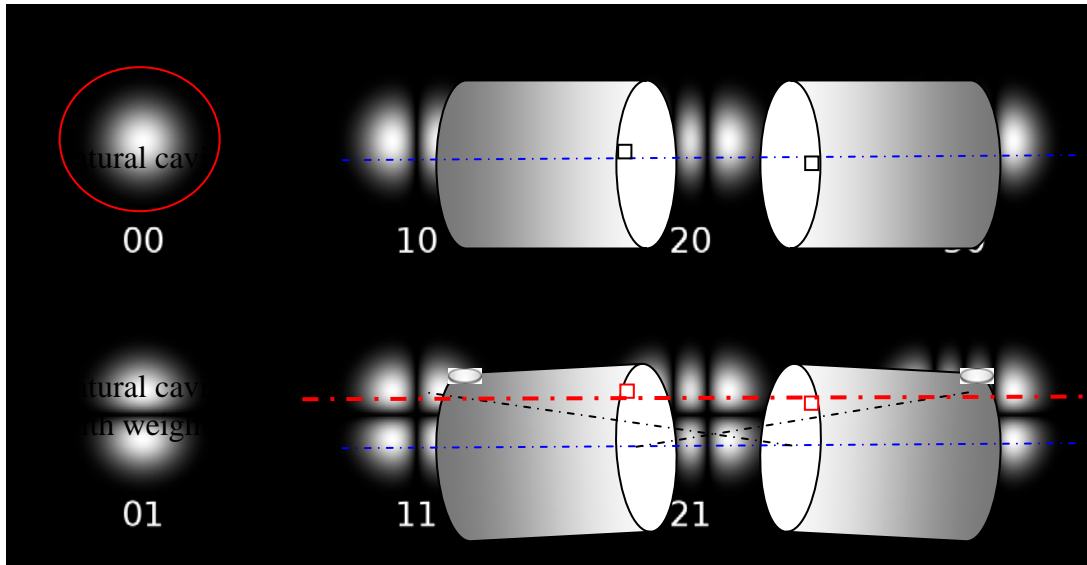

- when the reflected spots and the input beam were overlapped we used infra red laser
- three infrared sensitive cameras on the output table to see the beams coming from MC, NAC, and SAC
- we started seeing fringes
- in a F-B cavity there are different modes resulting from TEM_{nm} fields. We adjusted the periscope before the MC, the mirror and the BS before NAC and SAC until we saw a large and bright TEM_{00} spot for each cavity indicating that the cavities were properly aligned

Visibility

- A Fabry-Perot cavity is in resonance with the incident ray when the length of the cavity is equal to an integral number of wavelengths: the reflected power is 0
- As the signals passed through the resonance, we saw the dip of the reflected beam (visibility): the percentage of the reflected light relative to the transmitted
- We worked hard to increase the visibility of the TEM₀₀.

Visibility NAC 81%

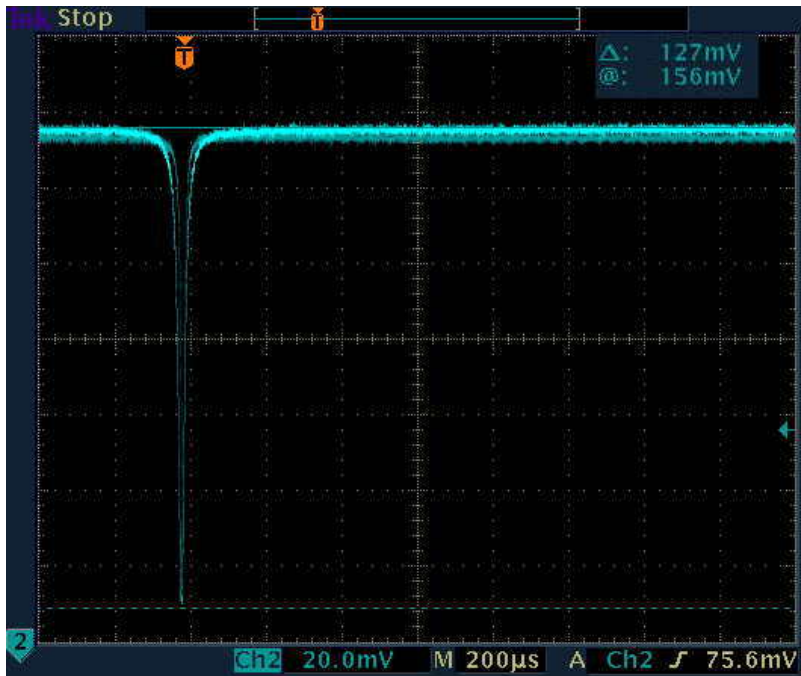

Visibility SAC 88%

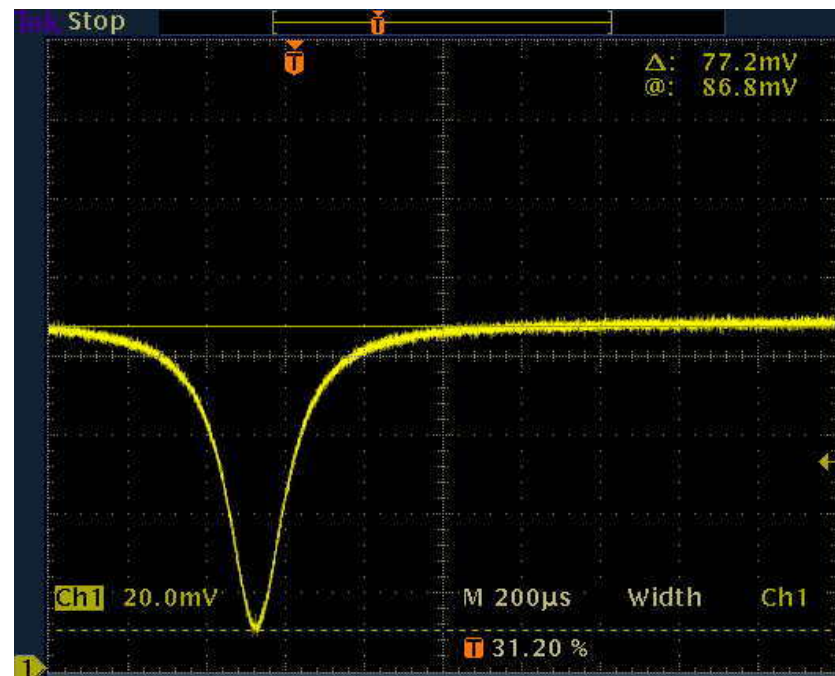

Visibility (vacuum chamber closed)

- The damping behind one of the MC mirrors didn't work properly
- Visibility at both cavities decreased

Visibility NAC 71% NAC

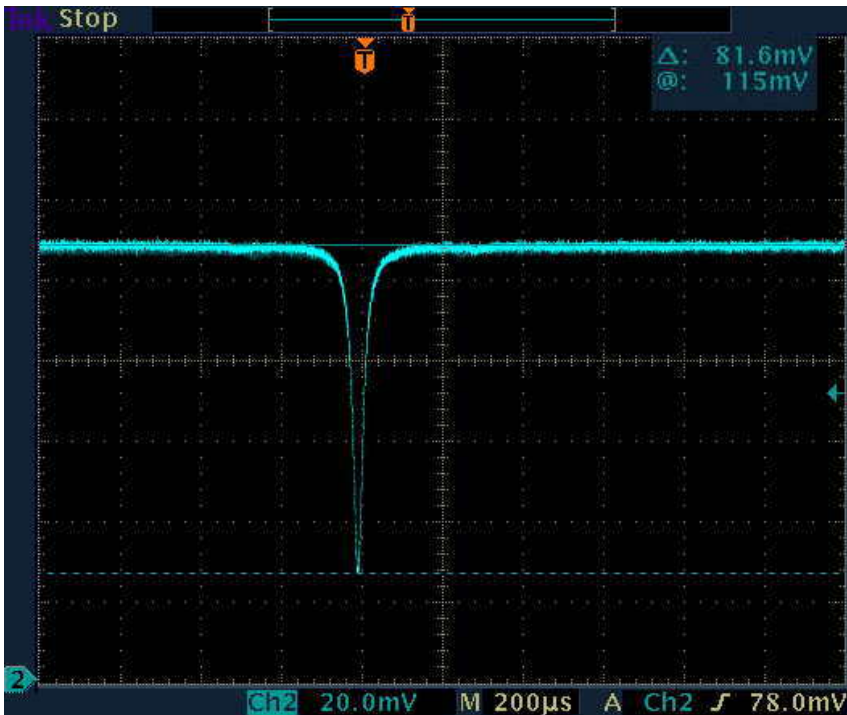

Visibility SAC 66%

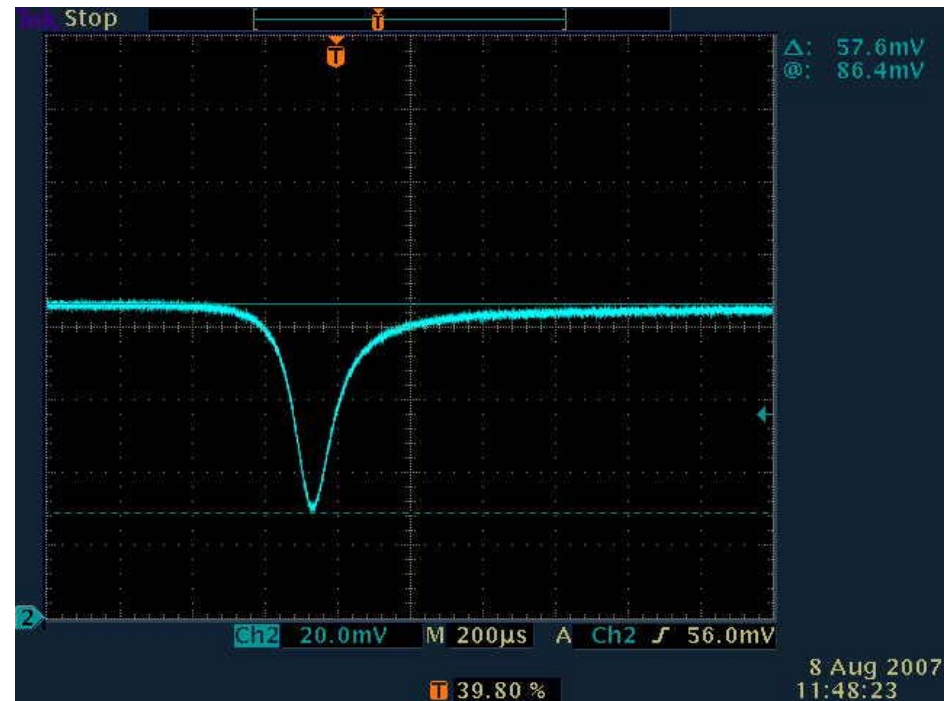

Servo system

- The system is constituted by a feedback that keeps the interferometer at a chosen operation point
- Servo used for locking the cavities and for acquiring data through PDH method

QuickTime™ and a
TIFF (Uncompressed) decompressor
are needed to see this picture.

D is the PDH discriminant

H is the electronic transfer
function of the servo filter

M is the transfer function
of the position actuators

C is the conversion factor

$$C = v / L$$

Extract length noise from error signal

$$\varepsilon = DC(\delta l - \varepsilon HM) \Rightarrow \delta l = \frac{1 + DHMC}{DC} \varepsilon$$

Calibration: finding a value for D

- H specified by design (and verified by direct measurement), C , M derived in previous works.
- Find a value for D

D depends on the cavity finesse, the laser wavelength, and the power in the sidebands and the carrier, so it changes every time that the set up changes

D was not found directly

We locked the cavities and measured the open loop transfer function through a spectral analyzer

$$V_{out} = V_{in} H M C D$$

QuickTime™ and a
TIFF (Uncompressed) decompressor
are needed to see this picture.

Calibration: finding a value for D

- Using known values from H, M and C we fitted a theoretical prediction of DHMC to this measurement with D an adjustable parameter
- Calibration for NAC and SAC separately

Measured (blue) and fit model (red) open loop transfer function for
NAC and SAC

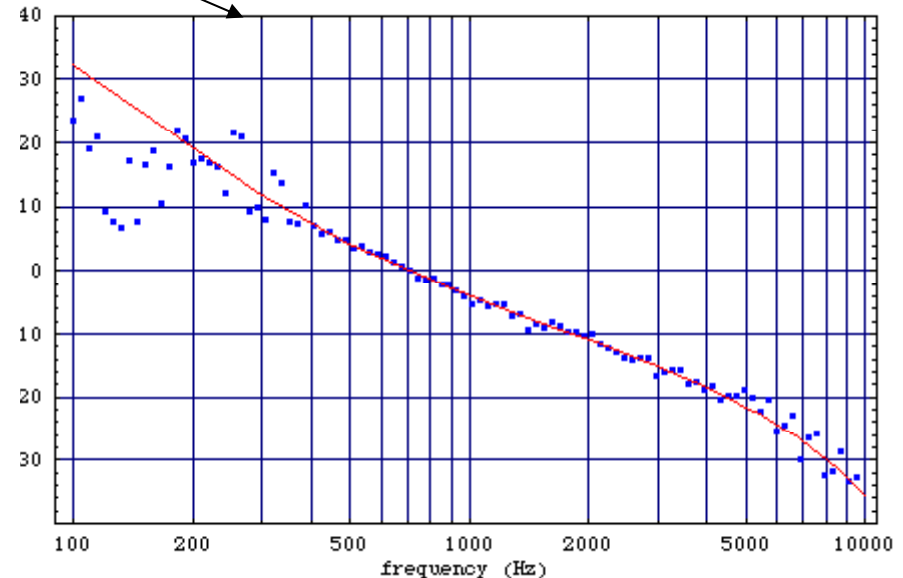
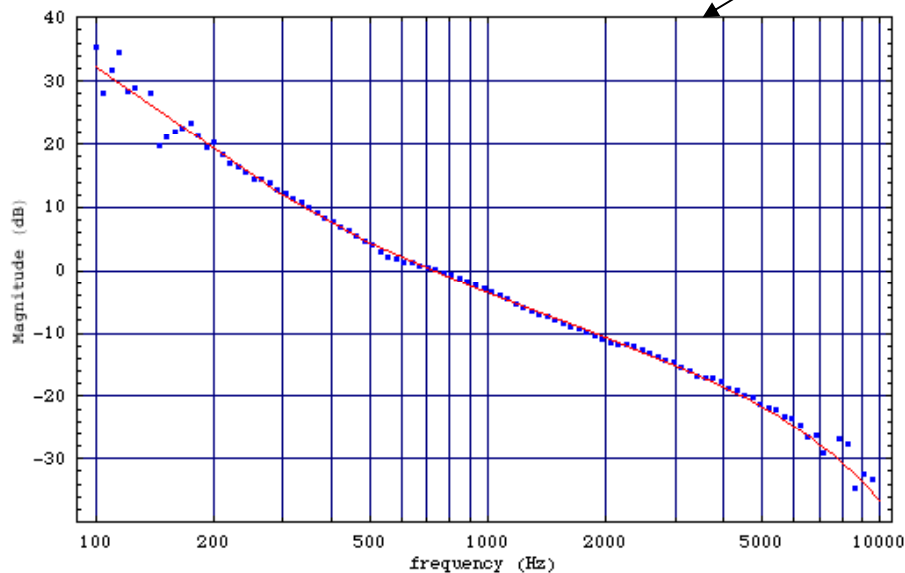

The value of D that best fits the experimental data is:

- 11.6 ± 0.012 V/MHz (NAC)
- 10.8 ± 0.010 V/MHz (SAC)

Equivalent length noise (SAC-NAC)

- Once we found the value of D , for each cavity, knowing the other response and the measured error signal, we calculated indirectly the equivalent length noise for SAC and NAC

At first glance the two curves look the same

zoom between 500 Hz to 10000 Hz
the slope is $f^{-1/2}$

TNI - Comparison NAC SAC total noise 8-9-07

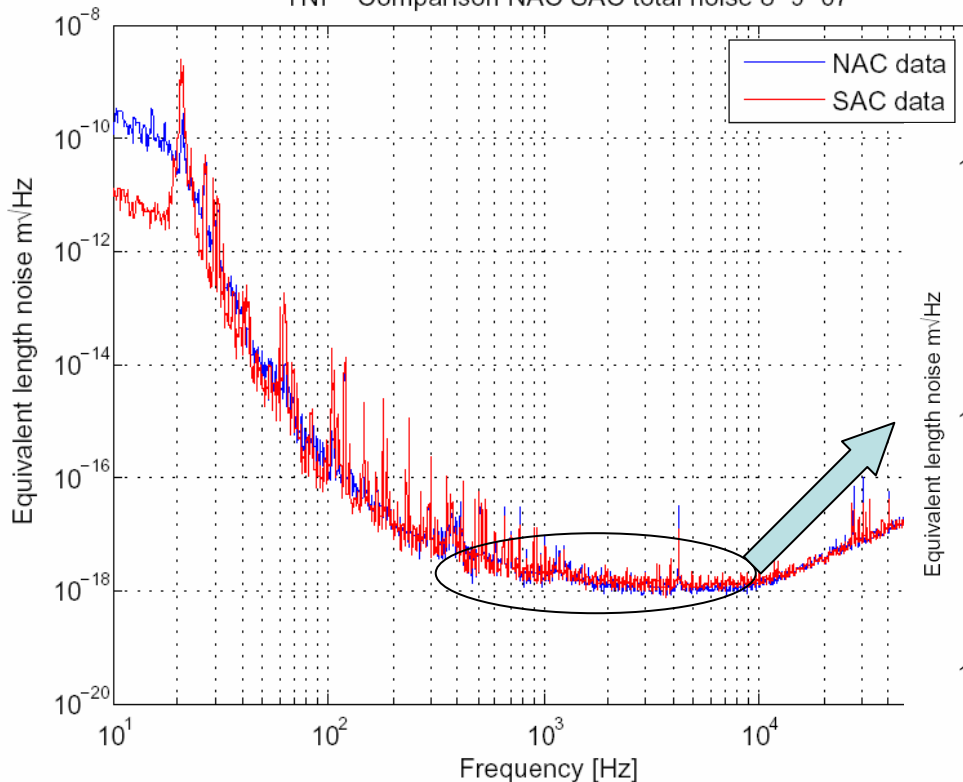

TNI - Comparison NAC SAC total noise 8-9-07

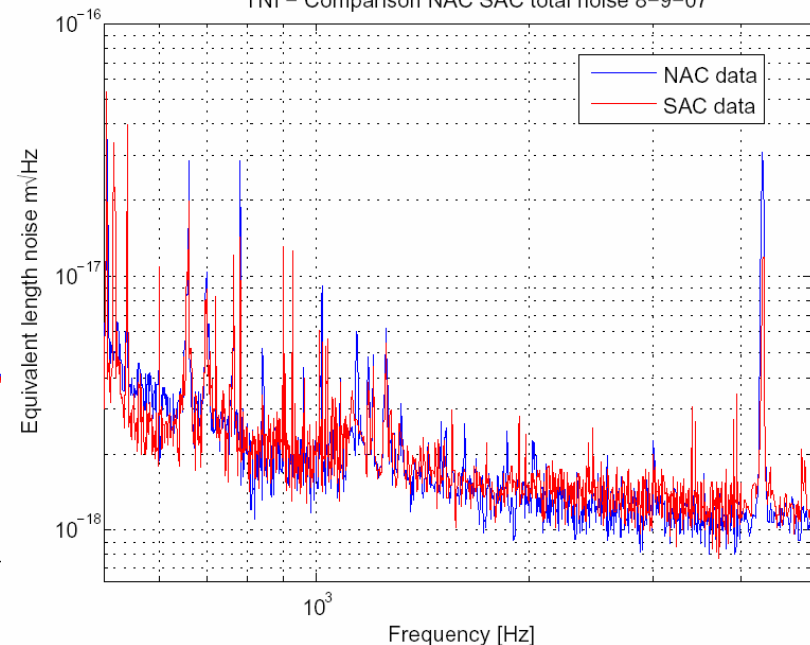

Fractional variation: Comparison between old and new data for NAC and SAC

$$\frac{(Lnoise_{old} - Lnoise_{new})}{(Lnoise_{old} + Lnoise_{new})}$$

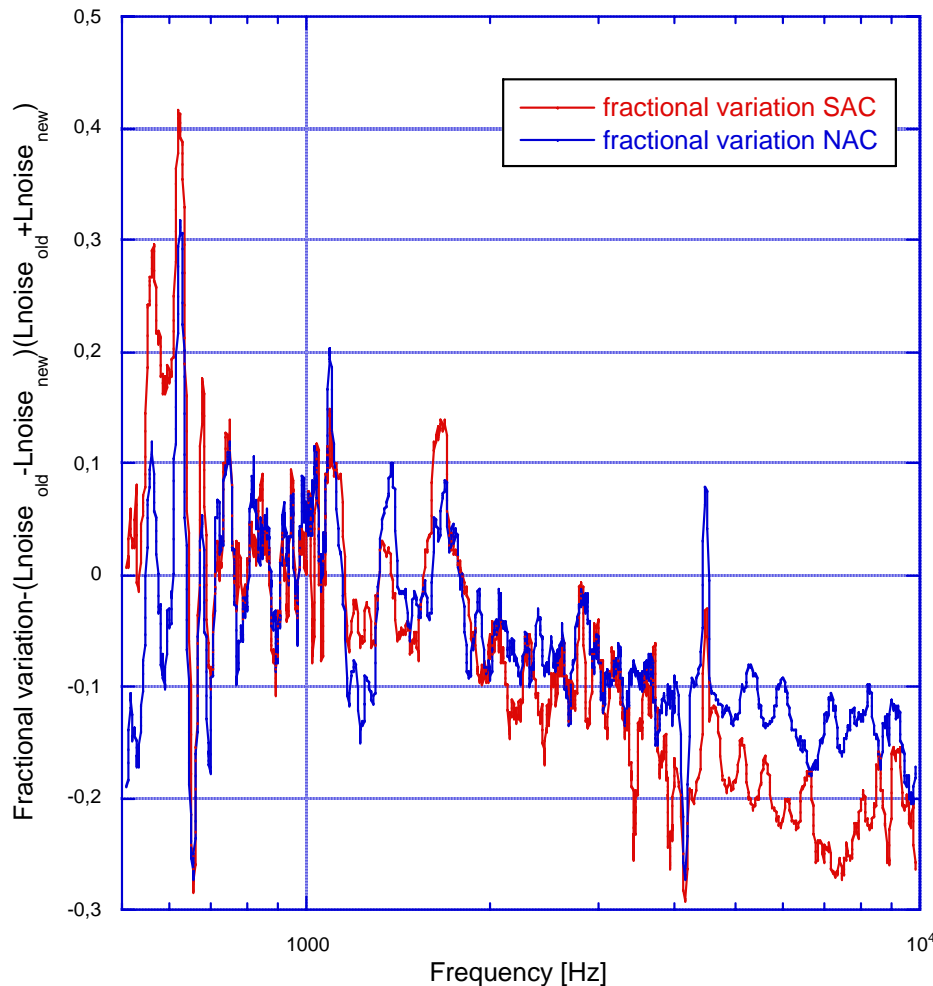

The trend of data is the same

Between 4000 Hz and 10000 Hz the two curves are far roughly 0.03

Fractional variation of SAC is lower: shot noise due to the poor visibility at SAC

Loss angle analysis (SAC)

- SAC data

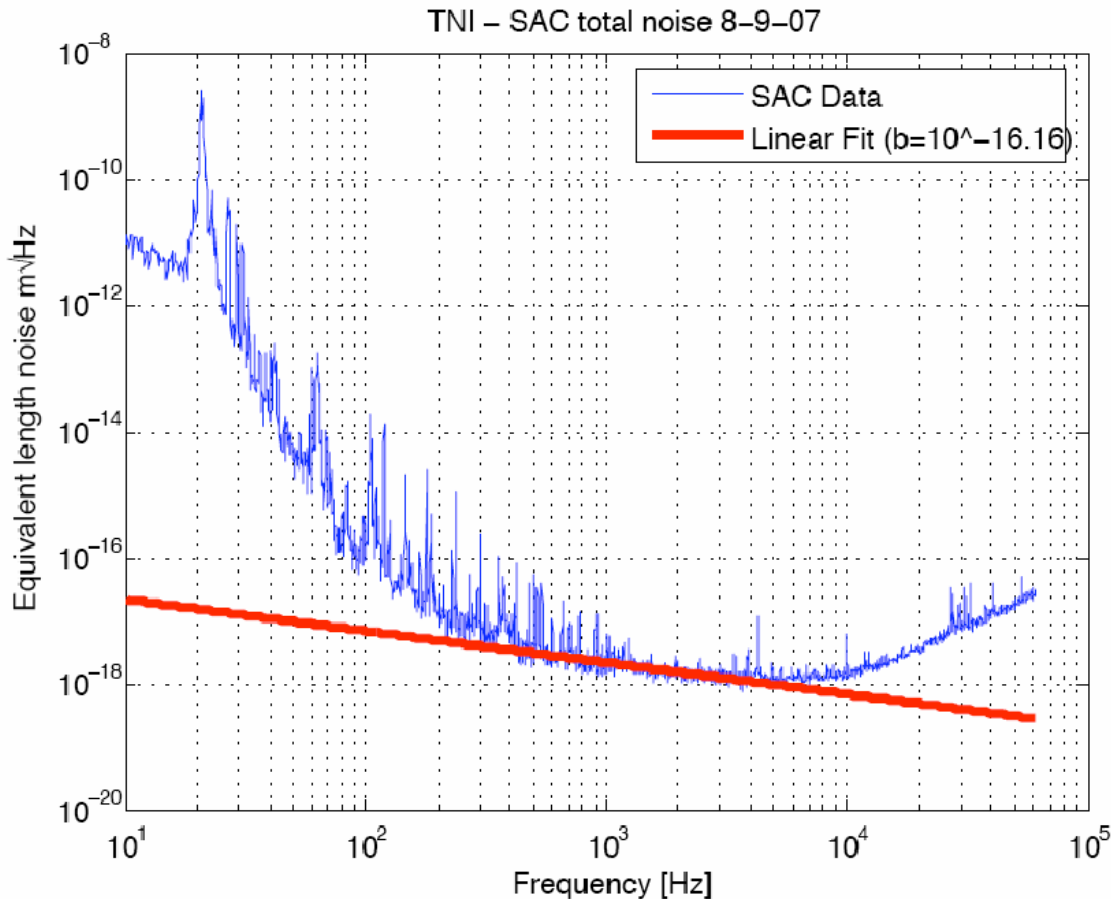

$$L_{\text{noise}} = A(\phi) f^{-1/2}$$

$$\log(L_{\text{noise}}) = \log(A(\phi)) - 1/2 \log f$$

fit line

$$y = b - 1/2 f$$

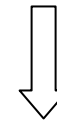

$$\log(A(\phi)) = b$$

$$\phi = 6.65 \times 10^{-4} \pm 0.35 \times 10^{-4}$$

Loss angle analysis (SAC)

- SAC data-without weights

TNI – SAC Previous Settings

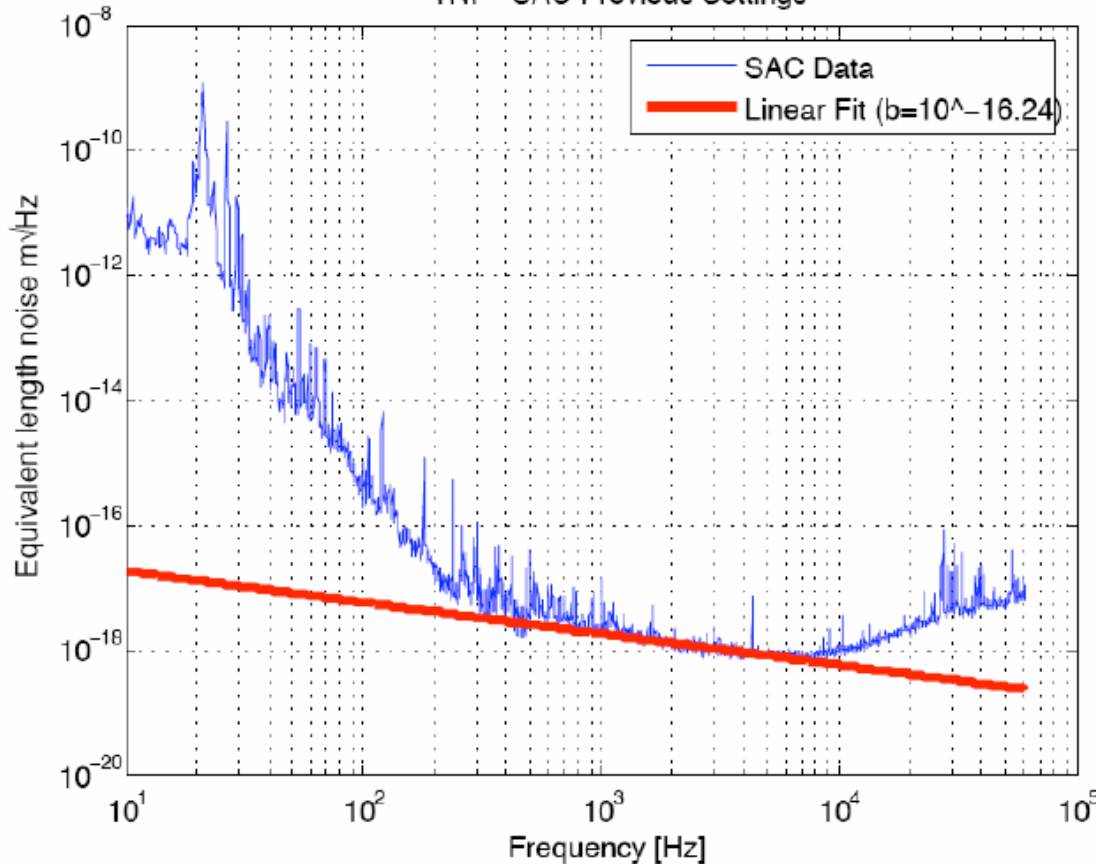

$$\phi = 6.54 \times 10^{-4} \pm 0.22 \times 10^{-4}$$

$$\Delta\phi = \left| \phi_{SAC(old)} - \phi_{SAC(new)} \right| = 0.11 \times 10^{-4} < 0.22 \times 10^{-4}$$

Loss angle analysis (NAC)

- NAC data

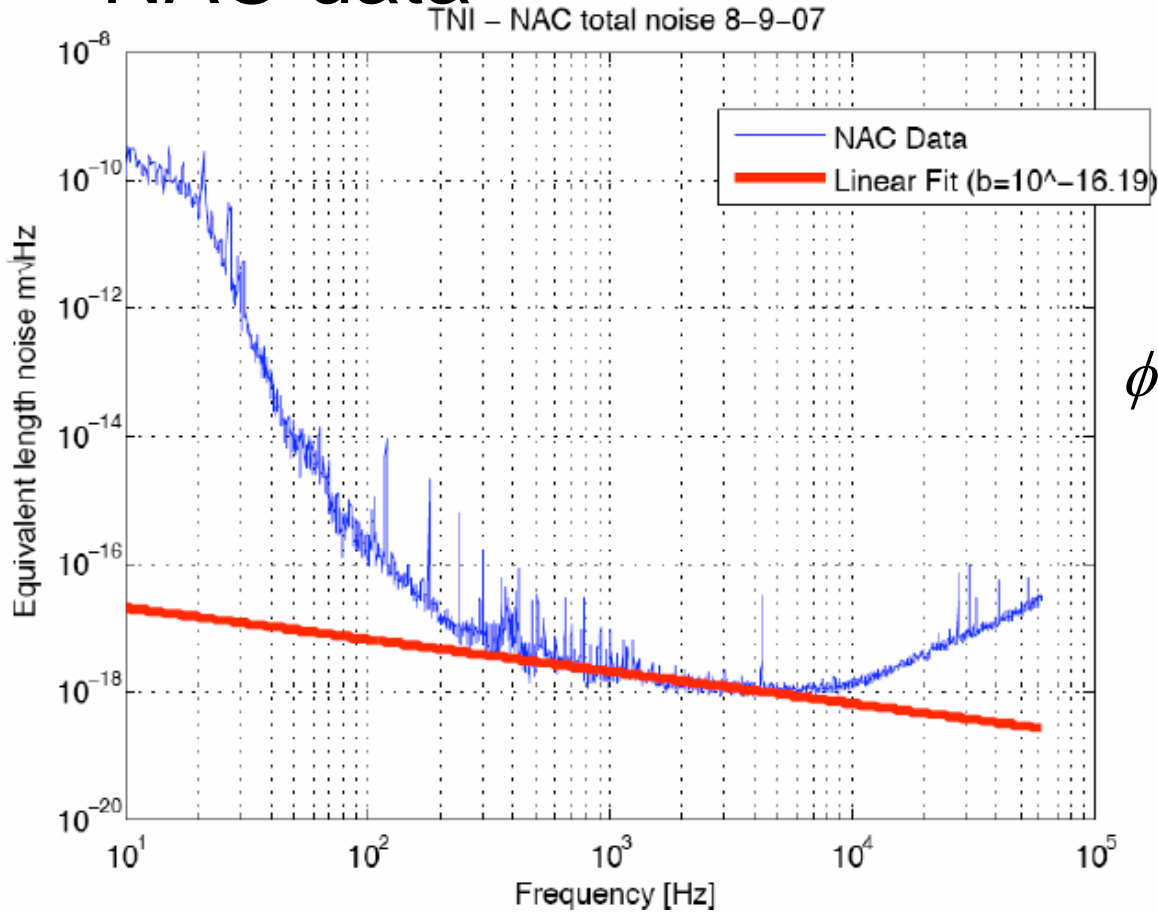

$$\phi = 6.43 \times 10^{-4} \pm 0.31 \times 10^{-4}$$

$$\Delta\phi = |\phi_{SAC} - \phi_{NAC}| = 0.22 \times 10^{-4} < 0.31 \times 10^{-4}$$

Conclusions

- In this work, we have verified the spatial homogeneity of mirror thermal noise at the Thermal Noise Interferometer (TNI)
- Main results
 - Visibility at both cavities was not high (NAC 71%, SAC 66%) like in the previous setting (about 90% at both cavities).
 - Although the difference in visibility, comparing the old data (without weights on the mirrors) and the new for NAC and SAC in the frequency range 500 Hz-10000 Hz, there is a variation of 3%
 - The difference between the coating loss angle for SAC in the previous setting and in this experiment (0.11×10^{-4}) is smaller than the error associated to the measure (0.22×10^{-4})
 - We can conclude that the coating thermal noise is uniform in two different points of the mirror

Future works

- Move the beam spot more than 3 mm vertically (and horizontally) and repeat the measure
- Measure the optimized coatings thermal noise

Acknowledgments

- Eric Black
- Innocenzo Pinto
- Vincenzo Galdi
- Riccardo DeSalvo
- Akira Villar
- Greg Ogin
- Tara Chalermongsak
- John Miller
- Valerio Boschi
- All friends at Caltech
- LIGO project
- NSF